

# RTC

## Stainless Steel Condensing Floor Standing Boilers

### Technical data sheet

High water content 3-pass stainless steel (316Ti) condensing boilers

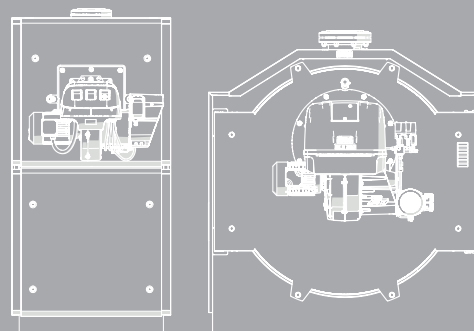

## HIGH EFFICIENCY COMMERCIAL HEATING

Stainless Steel Condensing Floor Standing Boilers

# RTC

### PRODUCT DESCRIPTION

The Riello RTC series of high-efficiency condensing boilers feature design flexibility for retrofit and new construction projects. The high mass design is tailored to fully meet space heating retrofit applications. The Multiple Return Connections, low & medium temperature, create maximum heat transfer along the second and third flue passes, increasing overall boiler efficiency. This series can be used with multiple fuels including natural gas and propane. The boiler insulation comes pre-installed and convenient top connections allow easy access to piping for reduced installation effort. Project costs are reduced thanks to simplified piping; a high water content heat exchanger requires no minimum flow rate, thus eliminating the need of a costly dedicated boiler circulator.

The titanium infused stainless steel (316Ti) heat exchanger is designed for greater strength and longer service life.

With inputs ranging from 3,000 up to 10,000 MBH, the RTC series has maximum operating pressure up to 160 psi and temperature up to 210 °F. The efficiency of the Riello RTC Series Condensing Boilers can reach up to 98%, reducing heating costs by up to 20% in comparison with conventional heating.

Condensing boiler technology is the most efficient and environmentally friendly form of fuel heating available today. Condensing technology recovers the condensation heat retained latently in flue gases, that is a part of energy that normally disappears up the chimney in other heating systems. Thanks to lower fuel consumption and lower heating costs, condensing boilers usually pay for themselves in few years. Additionally, a modern condensing heating system increases the value of the building as well as quality of life by reducing emissions. Condensing technology offers an intelligent, easy-to-install solution to rising fuel costs. High efficiency condensing equipment achieves qualifying points for LEED certification of commercial buildings.

Large heat-transfer surfaces, a counter-flow heat exchanger design and cold return water temperatures together optimize condensation opportunities.

The heat released from condensation is transmitted directly into the boiler water, minimizing thermal losses in the flue gases.

The RTC Series Condensing Boilers could be equipped with two-stage or modulating forced-draft burners, that achieve extremely low pollutant emissions meeting the most stringent NOx and CO requirements.

The fully modulating burner also maintains Riello standards for energy efficiency, longevity, reliability and construction quality.

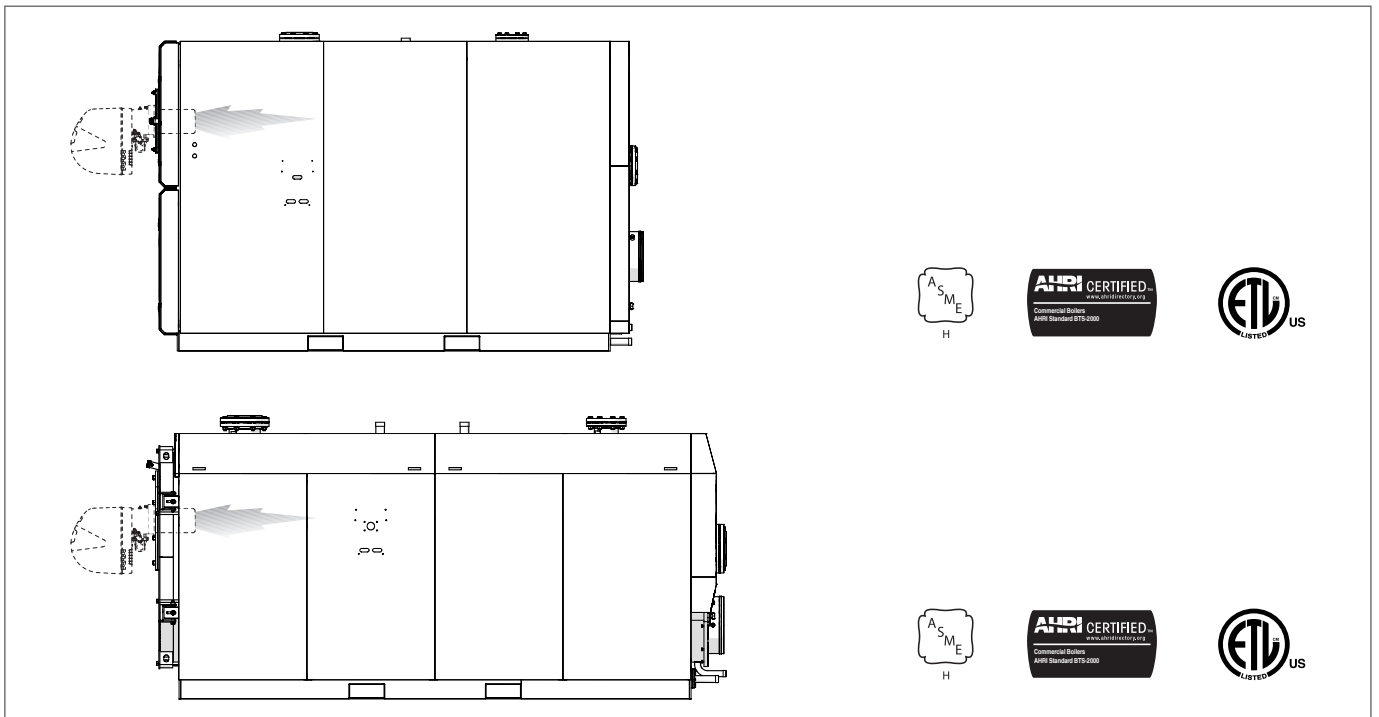

**FEATURES**

**Fuel options**

- Natural Gas, Propane or Dual Fuel (#2 fuel oil backup)
- Full Condensing on natural gas/propane
- Condensing capability on #2 fuel oil (<15 ppm sulfur content)

**Performance**

- Efficiency up to 98%
- 10:1 turndown ratio (10%) when firing on natural gas
- Pressure rating up to 160 psi
- NOx Emissions capable of 30 ppm or less at all firing rates when firing on natural gas
- Capable of variable primary flow installations

**Design: Structure and Materials**

- 3-pass Fire Tube heat exchanger
- High quality combined carbon steel/316Ti SS
- Dual return water connections
- Top connections for easy access to piping pre-installed boiler insulation
- One package for the jacket pack
- Easy Serviceability

**High performance and reduced installation cost and complexity**

- Multiple fuel options
- Low fuel consumption due to high efficiency
- Low emissions
- High water content
- Simple piping, no primary/secondary piping with extra circulator needed

**RATINGS**

Description		RTC 3000	RTC 4000	RTC 5000	RTC 6000	RTC 8000	RTC 10000
Min Input <sup>(1)</sup>	MBH	300	400	500	600	800	1000
Max Input	MBH	3,000	4,000	5,000	6,000	8,000	10,000
Output <sup>(2)</sup>	Condition 1 <sup>(3)</sup>	2,550	3,400	4,250	5,100	6,800	8,500
	Condition 2 <sup>(4)</sup>	2,940	3,920	4,900	5,880	7,840	9,800
Efficiency	Condition 1 <sup>(3)</sup>	85%	85%	85%	85%	85%	85%
	Condition 2 <sup>(4)</sup>	98%	98%	98%	98%	98%	98%
AHRI Efficiency		94%	94%	94%	94%	94%	94%

<sup>(1)</sup> Values based on natural gas firing

<sup>(2)</sup> Max output dependent upon application

<sup>(3)</sup> Condition 1 based on return temperature 180°F and ΔT 36°F

<sup>(4)</sup> Condition 2 based on return temperature 80°F and ΔT 36°F

**HIGH EFFICIENCY COMMERCIAL HEATING**  
Stainless Steel Condensing Floor Standing Boilers

**DIMENSIONS - RTC 3000-4000-5000-6000**

Description		RTC 3000	RTC 4000	RTC 5000	RTC 6000
A - Width	inch	39.4	41.3	43.3	46.1
	mm	1,000	1,050	1,100	1,170
B - Length	inch	119.3	127.8	137.4	145.3
	mm	3,030	3,245	3,490	3,690
C - Height	inch	79.1	82.9	86.8	92.3
	mm	2,010	2,106	2,205	2,345
D	inch	58.1	60.9	63.9	44.7
	mm	1,477	1,548	1,622	1,135
E	inch	46.9	48.7	51.5	54.7
	mm	1,192	1,238	1,307	1,390
F	inch	25.1	25.8	26.3	28.5
	mm	637	655	667	723

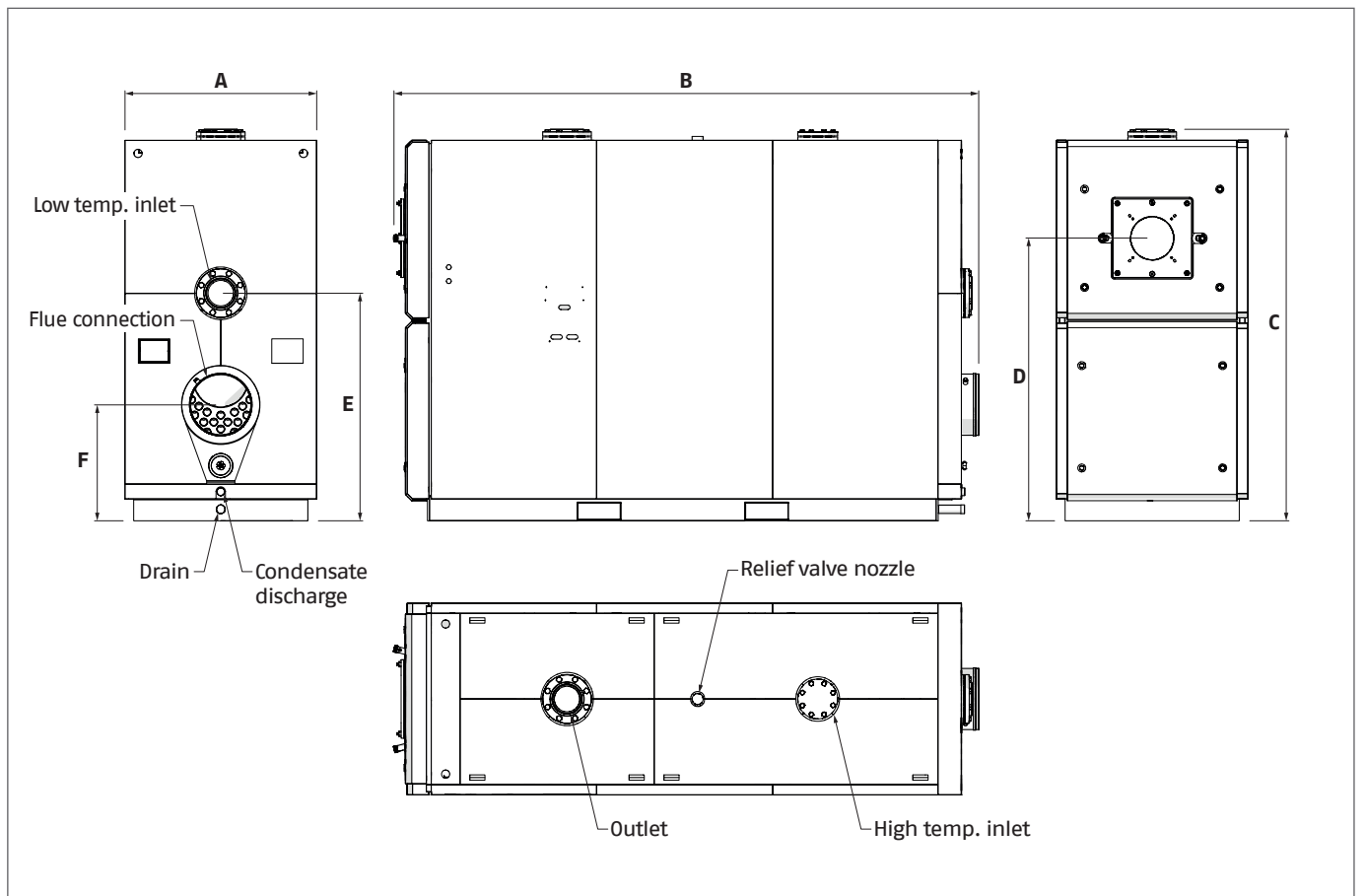

**DIMENSIONS – RTC 8000–10000**

Description		RTC 8000	RTC 10000
A - Width	inch	70.9	74.8
	mm	1,800	1,900
B - Length	inch	161.0	178.3
	mm	4,090	4,530
C - Height	inch	76.8	81.7
	mm	1,950	2,075
D	inch	49.6	53.1
	mm	1,260	1,350
E	inch	41.7	45.3
	mm	1,060	1,150
F	inch	20.5	21.7
	mm	521	550

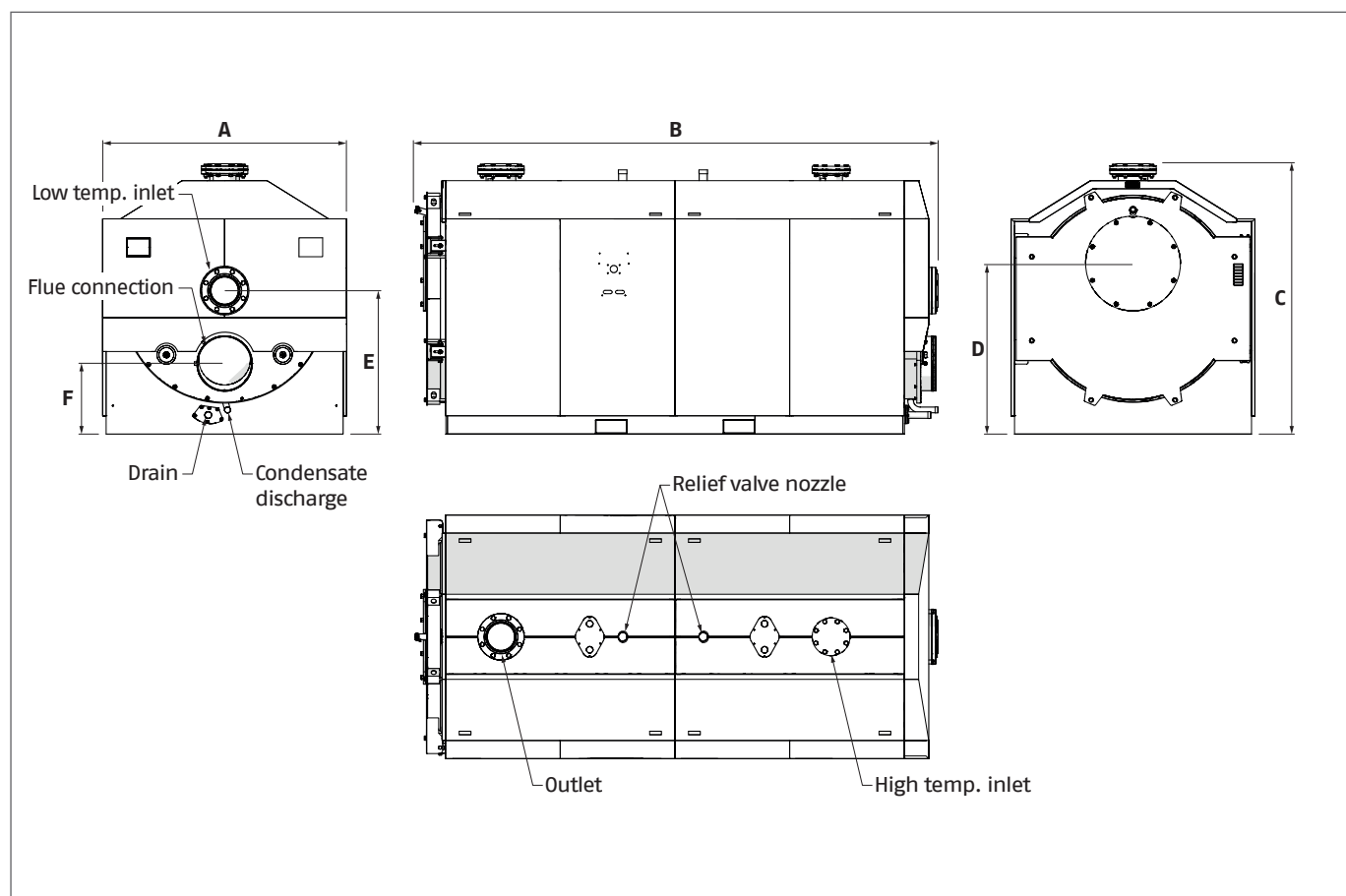

## HIGH EFFICIENCY COMMERCIAL HEATING

Stainless Steel Condensing Floor Standing Boilers

### SPECIFICATIONS

Description	RTC 3000	RTC 4000	RTC 5000	RTC 6000	RTC 8000	RTC 10000
Boiler category	ASME Section IV	ASME Section IV	ASME Section IV	ASME Section IV	ASME Section IV	ASME Section IV
Max allowable working pressure	160 psi	160 psi	160 psi	160 psi	160 psi	160 psi
Max allowable working temperature	210°F	210°F	210°F	210°F	210°F	210°F
Water Connections Inlet/Outlet (Flanged)	4"	6"	6"	6"	8"	8"
High Temp. Return Water Connections	3"	3"	4"	4"	6"	6"
Min. Water Flow (GPM)	0	0	0	0	0	0
Max. Water Flow (GPM)	360	550	650	750	1,150	1,250
Water Volume (gal)	354	420	489	597	951	1,255
Water Pressure Drop	1.7 psi at 300GPM	0.7 psi at 400GPM	0.6 psi at 500GPM	1.3 psi at 600GPM	1.1 psi at 800GPM	0.8 psi at 1000GPM
Turndown (Nat.Gas)	10:1	10:1	10:1	10:1	10:1	10:1
Vent/Air Intake Connections	10"	12"	14"	14"	16"	18"
Vent Materials	AISI 316L AL29-4C (29% Cr - 4% Mo)	AISI 316L AL29-4C (29% Cr - 4% Mo)	AISI 316L AL29-4C (29% Cr - 4% Mo)	AISI 316L AL29-4C (29% Cr - 4% Mo)	AISI 316L AL29-4C (29% Cr - 4% Mo)	AISI 316L AL29-4C (29% Cr - 4% Mo)
Type of Fuel	Natural Gas Propane #2 Fuel Oil (backup)	Natural Gas Propane #2 Fuel Oil (backup)	Natural Gas Propane #2 Fuel Oil (backup)	Natural Gas Propane #2 Fuel Oil (backup)	Natural Gas Propane #2 Fuel Oil (backup)	Natural Gas Propane #2 Fuel Oil (backup)
NOx Emissions <30ppm Capability on Nat. Gas	yes	yes	yes	yes	yes	yes
Temperature Control Range	80°F to 195°F	80°F to 195°F	80°F to 195°F	80°F to 195°F	80°F to 195°F	80°F to 195°F
Ambient Temperature Range	32°F to 140°F	32°F to 140°F	32°F to 140°F	32°F to 140°F	32°F to 140°F	32°F to 140°F
Standard Listings & Approvals	ASME, ETL, AHRI	ASME, ETL, AHRI	ASME, ETL, AHRI	ASME, ETL, AHRI	ASME, ETL, AHRI	ASME, ETL, AHRI
Weight (dry) lbs.	5,578	6,702	7,485	9,087	12,747	16,149
Weight (wet) lbs.	8,532	10,207	11,563	14,070	20,684	27,172
Shipping Weight lbs.	5,578	6,702	7,485	9,087	12,747	16,149

.....

.....

.....

.....

.....

.....

.....

.....

.....

.....

.....

.....

.....

.....

.....

.....

.....

.....

.....

.....

.....

.....

.....

RIELLO S.p.A. - 37045 Legnago (VR)  
tel. +39 0442 630111 - fax +39 0442 22378

RIELLO NORTH AMERICA

35 Pound Park Road  
Hingham, Massachusetts  
U.S.A. 02043

2165 Meadowpine Blvd  
Mississauga, Ontario  
Canada L5N 6H6

[www.rielloboilers.com](http://www.rielloboilers.com)

The manufacturer strives to continuously improve all products. Appearance, dimensions, technical specifications, standard equipment and accessories are therefore liable to modification without notice.

**RIELLO**