

Array AR 3000 – AR 4000

US INSTALLATION AND OPERATION MANUAL

RIELLO

Dear heating engineer,
 Congratulations for proposing a **RIELLO** boiler. This appliance ensures maximum comfort for an extended period, with high reliability, efficiency, quality and safety.
 This manual provides information that is essential to the installation of the appliance. Used in conjunction with your own knowledge and expertise it will enable you to install the appliance quickly, easily, and correctly.

Please accept our thanks and our congratulations on your choice of product.
RIELLO S.p.A.

CONFORMITY

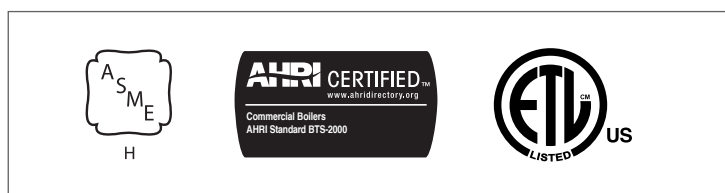

The information contained in this manual is subject to change without notice from **RIELLO** SpA. **RIELLO** makes no warranty of any kind with respect to this material, including but not limited to implied warranties of merchantability and fitness for a particular application. **RIELLO** is not liable for errors appearing in this manual. Nor for incidental or consequential damages occurring in connection with the furnishing, performance, or use of this material.

RANGE

MODEL	CODE
Array AR 3000	20115025
Array AR 4000	20115026

⚠ WARNING: If the information in these instructions is not followed exactly, a fire or explosion may result causing property damage, personal injury or death.

⚠ WARNING: Do not store or use gasoline or other flammable vapors and liquids in the vicinity of this or any other appliance.

WHAT TO DO IF YOU SMELL GAS:

- Do not try to light any appliance,
- Do not touch any electrical switch; do not use any phone in your building,
- Immediately call your gas supplier from a neighbor's phone. Follow the gas supplier's instructions,
- If you cannot reach your gas supplier, call the fire department.

Qualified installer, service agency or the gas supplier must perform installation and service.

⚠ FOR YOUR SAFETY: Improper installation and/or operation could create carbon monoxide gas in flue gases which could cause serious injury, property damage, or death. Improper installation and/or operation will void the warranty.

CONTENTS

1 GENERAL	4	4 OPERATION	25
1.1 Warnings & cautions	4	4.3 Touchscreen control panel menus	25
1.2 Emergency shutdown	5	4.3.1 Riello Screen	25
1.3 Prolonged shutdown	5	4.3.2 Cascade Screen	25
2 INSTALLATION	6	4.3.3 Boiler Screen	26
2.1 Introduction	6	4.3.4 Module Screen	26
2.2 Receiving the unit	6	4.3.5 Performance Screen	26
2.3 Unpacking	6	4.3.6 Error Screen	27
2.4 Site preparation	6	4.3.7 Service Screen	27
2.4.1 Installation clearances	7	4.3.8 Module Test Screen	27
2.4.2 Setting the Unit	7	5 SHUTDOWN	28
2.5 Boiler location	8	5.1 Shutting down the heating system	28
2.6 Supply and return piping	9	5.2 Shutting down the heating system in an emergency ..	28
2.7 Low water cutoff	10	6 ENVIRONMENTAL PROTECTION/DISPOSAL	28
2.8 High limit safety switch	10	APPENDIX	29
2.11.1 Gas Supply Specifications	11	Appendix A - Wiring diagram	29
2.11.2 Manual Gas Shutoff Valve	11	Appendix B - Size and connections	34
2.11.3 External Gas Supply Regulator	12	Appendix C - Connection diagram	35
2.11.4 Gas Type Conversion	12	Appendix D - Technical data	37
2.11.5 Adjusting and setting CO ₂ limits	13	Appendix E - Structure	38
2.12 AC electrical power wiring	13	Appendix F - Maintenance	40
2.12.1 Electrical Power Requirements	14	Appendix G - Head available for the system	41
2.13 Field control wiring	15	Appendix H - De-rating for altitude installation	42
2.13.1 Room Thermostat Connection (Enable/Disable)	15	Appendix I - Efficiency Curves	43
2.13.2 Air Damper	15	Appendix J - Troubleshooting table	44
2.13.3 Outdoor Temperature Sensor	15	Appendix K - BOILER Installation (example drawings)	50
2.14 Venting	16	Appendix L - Ladder diagram	52
2.15 Combustion air	19	Appendix M - Venting size data	63
2.15.1 Combustion air from outside the building	20	Appendix N - Exhaust terminals and Air inlet Clearances ..	64
2.15.2 Combustion air from inside the building	20	Appendix O - Sensor Resistance	66
2.15.3 Ducted combustion air	20		
3 COMMISSIONING	21		
3.4.1 Confirming the Unit's Gas Type	21		
3.4.2 Gas Type Conversion	21		
3.5 Boiler startup procedure	22		
3.5.1 Minimum Water Flow (Heat Exchanger Protection) ..	23		
3.5.2 Heating System Pressure Test	23		
3.6 Boilers' cascade installation and start-up	24		
3.6.1 Boilers Cascade: Set Boiler Address	24		
3.6.2 Boilers Cascade: Set Power switch S1	24		

The following symbols are used in this manual:

 **CAUTION!** = Identifies actions that require caution and adequate preparation.

 **STOP!** = Identifies actions that you MUST NOT do.

1 GENERAL

The **RIELLO Array AR 3000** and **AR 4000** MBH Boilers are modulating and condensing units. They represent a true industry advance that meets the needs of today's energy and environmental concerns. Designed for application in any closed loop hydronic system, the **Array's** modulating capability matches energy input directly to fluctuating system loads. The turn down ratio for these models is 30:1 for **AR 3000** and 40:1 for **AR 4000**. These **Array** models provide extremely high efficiency operation and are ideally suited for modern low temperature, as well as, conventional heating systems.

The **Array** Models **AR 3000** and **AR 4000** operate within the following input and output ranges:

Array model	Input Range (BTU/hr.)		Output Range(*) (BTU/hr.)	
	Minimum	Maximum	Minimum	Maximum
AR 3000	100,000	3,000,000	96,100	2,883,000
AR 4000	100,000	4,000,000	96,100	3,844,000

(*) The output of the boiler is a function of the unit's firing rate, return water temperature and BTU content of gas supply.

Array Series of hot water boilers has been designed in compliance with the CSD-1 code.

When installed and operated in accordance with this Instruction Manual, these boilers comply with the NO_x emission standards outlined in:

South Coast Air Quality Management District (SCAQMD), Rule 1146.2

Whether used in singular or modular arrangements, the **AR 3000** and **AR 4000** offer the maximum venting flexibility with minimum installation space requirements. These Boilers are Category IV, positive pressure appliances. Single and/or multiple breeched units are capable of operation in the following vent configurations:

- Conventional, Vertical Conventional,
- Sidewall Conventional, Direct Vent,
- Vertical Sealed, Direct Vent, Horizontal

These boilers are capable of being vented utilizing PP, CPVC, Stainless steel AL29-4C vent systems.

The **Array's** advanced electronics are available in several selectable modes of operation offering the most efficient operating methods and energy management system integration.

⚠ IMPORTANT: Unless otherwise specified, all descriptions and procedures provided in this Installation & Operation Manual apply to the **Array** series of boiler.

1.1 Warnings & cautions

Installers and operating personnel **MUST**, at all times, observe all safety regulations. The following warnings and cautions are general and must be given the same attention as specific precautions included in these instructions.

In addition to all the requirements included in this **RIELLO** Instruction Manual, the installation of units **MUST** conform with local building codes, or, in the absence of local codes, ANSI Z223.1 (National Fuel Gas Code Publication No. NFPA-54) for gas-fired boilers and ANSI/NFPA58 for LP gas-fired boilers.

Where applicable, the equipment shall be installed in accordance with the current Installation Code for Gas Burning Appliances and Equipment, CSA B149.1, and applicable Provincial regulations for the class; which should be carefully followed in all cases.

Authorities having jurisdiction should be consulted before installations are made.

See pages 10 – 11 for important information regarding installation of units within the Commonwealth of Massachusetts.

⚠ IMPORTANT: This Instruction Manual is an integral part of the product and must be maintained in legible condition. It must be given to the user by the installer and kept in a safe place for future reference.

⚠ WARNING: Do not use matches, candles, flames, or other sources of ignition to check for gas leaks.

⚠ WARNING: Fluids under pressure may cause injury to personnel or damage to equipment when released. Be sure to shut off all incoming and outgoing water shutoff valves. Carefully decrease all trapped pressures to zero before performing maintenance.

⚠ WARNING: Before attempting to perform any maintenance on the unit, shut off all gas and electrical inputs to the unit.

⚠ WARNING: The exhaust vent pipe of the unit operates under a positive pressure and therefore must be completely sealed to prevent leakage of combustion products into living spaces.

⚠ WARNING: Electrical voltages up to 230 vac maybe used in this equipment. Therefore the cover on the unit's power box (located behind the front panel door) must be installed at all times, except during maintenance and servicing.

⚠ CAUTION: Many soaps used for gas pipe leak testing are corrosive to metals. The piping must be rinsed thoroughly with clean water after leak checks have been completed.

⊖ CAUTION: DO NOT use this boiler if any part has been under water. Call a qualified service technician to inspect and replace any part that has been under water.

1.2 Emergency shutdown

If overheating occurs or the gas supply fails to shut off, close the manual gas shutoff valve (Fig. 1) located external to the unit.

NOTE: The Installer must identify and indicate the location of the emergency shutdown.

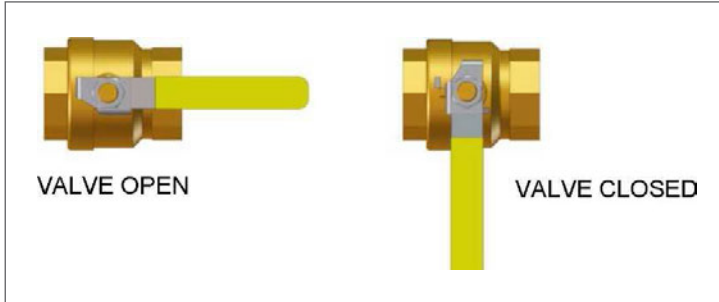

Fig. 1 Manual Gas Shutoff Valve

1.3 Prolonged shutdown

After prolonged shutdown, it is recommended that the startup procedures and the safety device test procedures of this manual be performed, to verify all system-operating parameters.

If there is an emergency, turn off the electrical power supply to the **RIELLO** boiler and close the manual gas valve located upstream the unit. The installer must identify the emergency shut-off device.

IMPORTANT – FOR MASSACHUSETTS INSTALLATIONS

Boiler Installations within the Commonwealth of Massachusetts must conform to the following requirements:

- Boiler must be installed by a plumber or a gas fitter who is licensed within the Commonwealth of Massachusetts.
- Prior to unit operation, the complete gas train and all connections must be leak tested using a non-corrosive soap.
- The vent termination must be located a minimum of 4 feet above grade level. If side-wall venting is used, the installation must conform to the following requirements extracted from 248 CMR 5.08 (2):

(a) For all side wall horizontally vented gas fueled equipment installed in every dwelling, building or structure used in whole or in part for residential purposes, including those owned or operated by the Commonwealth and where the side wall exhaust vent termination is less than seven (7) feet above finished grade in the area of the venting, including but not limited to decks and porches, the following requirements shall be satisfied:

1. INSTALLATION OF CARBON MONOXIDE DETECTORS

At the time of installation of the side wall horizontal vented gas fueled equipment, the installing plumber or gasfitter shall observe that a hard wired carbon monoxide detector with an alarm and battery back-up is installed on the floor level where the gas equipment is to be installed.

In addition, the installing plumber or gasfitter shall observe that a battery operated or hard wired carbon monoxide detector with an alarm is installed on each additional level of the dwelling, building or structure served by the side wall horizontal vented gas fueled equipment. It shall be the responsibility of the property owner to secure the services of qualified licensed professionals for the installation of hard wired carbon monoxide detectors.

- a. In the event that the side wall horizontally vented gas fueled equipment is installed in a crawl space or an attic, the hard wired carbon monoxide detector with alarm and battery back-up may be installed on the next adjacent floor level.
- b. In the event that the requirements of this subdivision cannot be met at the time of completion of installation, the owner shall have a period of thirty (30) days to comply with the above requirements; provided, however, that during said thirty (30) days period, a battery operated carbon monoxide detector with an alarm shall be installed.

2. APPROVED CARBON MONOXIDE DETECTORS

Each carbon monoxide detector as required in accordance with the above provisions shall comply with NFPA 720 and be ANSI/UL 2034 listed and IAS certified.

3. SIGNAGE

A metal or plastic identification plate shall be permanently mounted to the exterior of the building at a minimum height of eight (8) feet above grade directly in line with the exhaust vent terminal for the horizontally vented gas fueled heating appliance or equipment.

The sign shall read, in print size no less than one-half (1/2) inch in size, **"GAS VENT DIRECTLY BELOW. KEEP CLEAR OF ALL OBSTRUCTIONS"**.

4. INSPECTION

The state or local gas inspector of the side wall horizontally vented gas fueled equipment shall not approve the installation unless, upon inspection, the inspector observes carbon monoxide detectors and signage installed in accordance with the provisions of 248 CMR 5.08(2)(a)1 through 4.

(b) EXEMPTIONS:

The following equipment is exempt from 248 CMR 5.08(2)(a)1 through 4:

1. The equipment listed in Chapter 10 entitled "Equipment Not Required To Be Vented" in the most current edition of NFPA 54 as adopted by the Board; and
2. Product Approved side wall horizontally vented gas fueled equipment installed in a room or structure separate from the dwelling, building or structure used in whole or in part for residential purposes.

(c) MANUFACTURER REQUIREMENTS – GAS EQUIPMENT VENTING SYSTEM PROVIDED

When the manufacturer of Product Approved side wall horizontally vented gas equipment provides a venting system design or venting system components with the equipment, the instructions provided by the manufacturer for installation of the equipment and the venting system shall include:

1. Detailed instructions for the installation of the venting system design or the venting system components; and
2. A complete parts list for the venting system design or venting system.

(d) MANUFACTURER REQUIREMENTS – GAS EQUIPMENT VENTING SYSTEM NOT PROVIDED

When the manufacturer of a Product Approved side wall horizontally vented gas fueled equipment does not provide the parts for venting the flue gases, but identifies “special venting systems”, the following requirements shall be satisfied by the manufacturer:

1. The referenced “special venting system” instructions shall be included with the appliance or equipment installation instructions; and
2. The “special venting systems” shall be Product Approved by the Board, and the instructions for that system shall include a parts list and detailed installation instructions.

(e) A copy of all installation instructions for all Product Approved side wall horizontally vented gas fueled equipment, all venting instructions, all parts lists for venting instructions, and/or all venting design instructions shall remain with the appliance or equipment at the completion of the installation.

[End of Extracted Information From 248 CMR 5.08 (2)]

2 INSTALLATION

2.1 Introduction

This Chapter provides the descriptions and procedures necessary to unpack, inspect and install the **RIELLO Array Boiler Model AR 3000 and AR 4000**.

2.2 Receiving the unit

Each **Array** Boiler System is shipped as a single crated unit. The unit must be moved with the proper lifting equipment for safety and to avoid equipment damage. The unit should be completely inspected for evidence of shipping damage and shipment completeness at the time of receipt from the carrier and before the bill of lading is signed.

NOTE: RIELLO is not responsible for lost or damaged freight. Any visual damage to the packaging materials should be made clear to the delivering carrier.

2.3 Unpacking

Carefully unpack the unit, pay particular attention not to damage the unit enclosure when cutting away packaging materials. After unpacking, a close inspection of the unit should be made to ensure that there is no evidence of damage. The freight carrier should be notified immediately if any damage is detected.

The following accessories come standard with each unit and are either packed separately within the unit’s shipping container or are factory installed on the unit:

- Pressure/Temperature Gauge
- ASME Pressure Relief Valves
- Condensate Drain Traps
- Outdoor Sensor
- System Supply Sensor (length: 20’)
- Connection Cable between 905PB internal display and 905MN boards
- Venting adapter 10” down to 8”
- Stainless steel air intake adapter 8”

When optional accessories are ordered, they may be packed within the unit’s shipping container, factory installed on the unit, or packed and shipped in a separate container. Any standard or optional accessories shipped loose should be identified and stored in a safe place until ready for installation or use.

2.4 Site preparation

Ensure that the site selected for installation of the **Array AR 3000 and AR 4000** Boiler includes:

- Access to AC Input Power at 230 VAC, Phase-Phase-Neutral, 60 Hz @ 24 FLA
- Access to Natural Gas line at a recommended minimum pressure of 8 inches W.C. for 3,000,000 BTU/hr energy input for the **AR 3000** OR 4,000,000 BTU/hr energy input for the **AR 4000**.

2.4.1 Installation clearances

The **Array** models **AR 3000** and **AR 4000** are packaged in an enclosure having identical size.

The unit must be installed with the prescribed clearances for service as shown in Fig. 2. The minimum clearance dimensions, required by **RIELLO**, are listed below. However, if Local Building Codes require additional clearances, these codes shall supersede **RIELLO**'s requirements. Minimum acceptable clearances required are as follows:

Minimum acceptable clearances required are as follows:

- Sides: 24 inches
- Front: 31.5 inches
- Rear: 24 inches
- Top: 24 inches

All gas piping, water piping and electrical conduit or cable must be arranged so that they do not interfere with the removal of any panels, or inhibit service or maintenance of the unit.

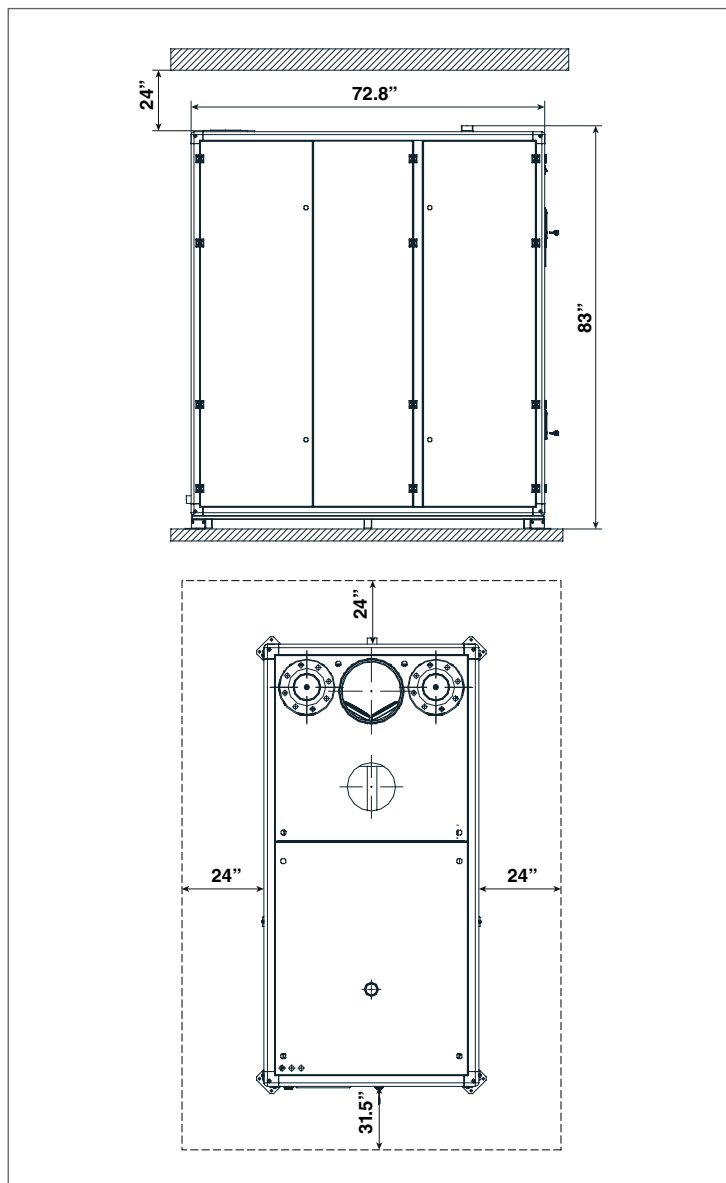

Fig. 2 Array AR 3000, AR 3000 Clearances

⚠ WARNING: Keep the unit area clear and free from all combustible materials and flammable vapors or liquids.

⚠ CAUTION: While packaged in the shipping container, the unit must be moved by pallet jack or forklift from the **SIDE ONLY**.

FOR MASSACHUSETTS ONLY:

For Massachusetts installations, the unit must be installed by a plumber or gasfitter licensed within the Commonwealth of Massachusetts. In addition, the installation must comply with all requirements specified in "Warnings & cautions" pag. 4.

2.4.2 Setting the Unit

Remove the top and side wooden panels, the plastic film and the polystyrene sheets. Remove the lag screws securing the unit to the shipping skid. Lift the unit off the shipping skid with a forklift and position it on the floor in the desired location.

⚠ WARNING: When lifting or moving the boiler: do not attempt to manipulate the boiler using the top water flanges or any other component of the boiler.

⚠ WARNING: When lifting or moving the boiler with a forklift: make sure the forks are longer than the boiler size (width or depth) so that forks stick out as per Fig. 3.

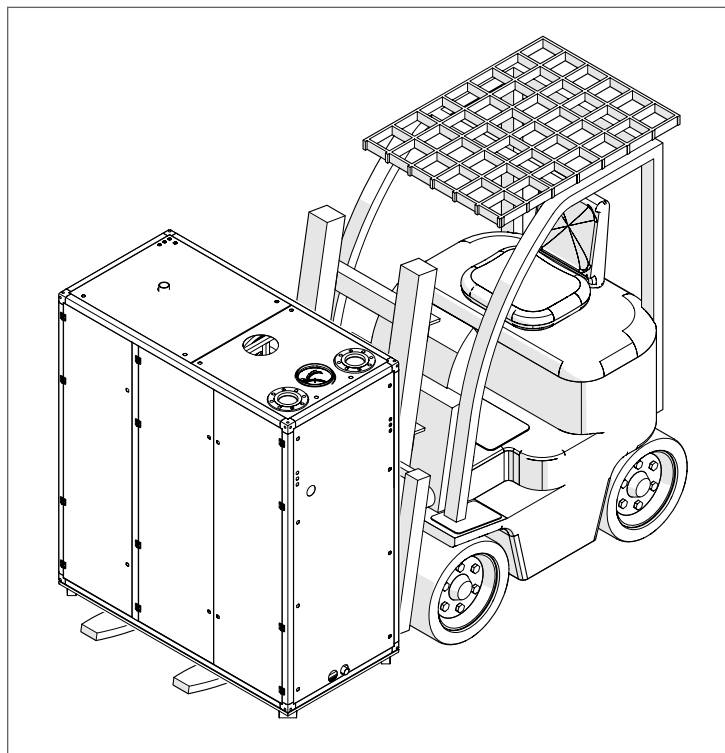

Fig. 3 Array AR 3000 and AR 4000 Forklift Handling

If a crane is required, the boiler must be lifted through bands.

⚠ WARNING: When lifting the boiler with crane: use bands, no chains. Bands must comply with federal, state and local rules.

⚠ WARNING: When lifting the boiler with crane: the bands must be positioned according to the Fig. 4.

In multiple unit installations, it is important to plan the position of each unit in advance. Sufficient space for piping connections and future service/maintenance requirements must also be taken into consideration. All piping must include ample provisions for expansion.

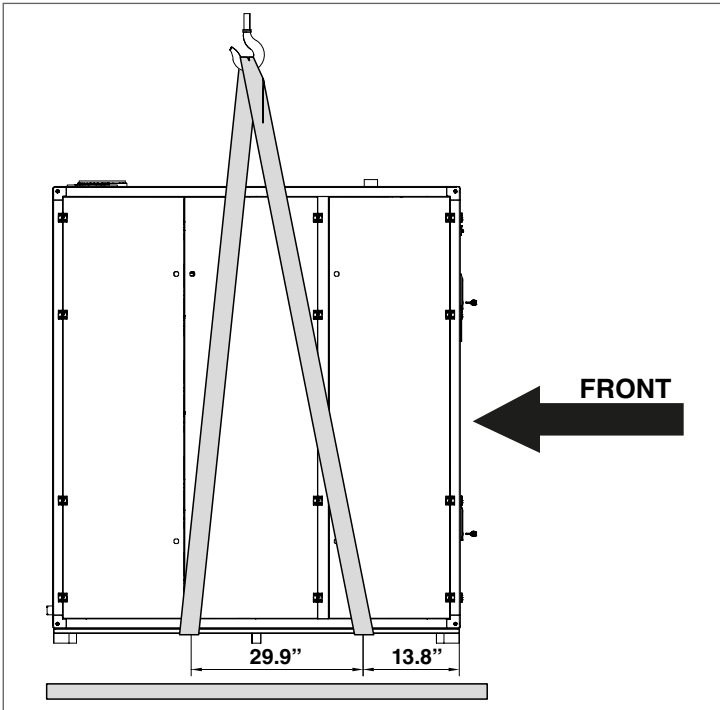

Fig. 4 Array AR 3000 and AR 4000 Crane Lifting Handling

The unit must be installed on a concrete flat floor, with no gradient in any direction, to ensure proper condensate and water drainage (see Fig. 5). If anchoring the unit, refer to Fig. 6 for anchor locations.

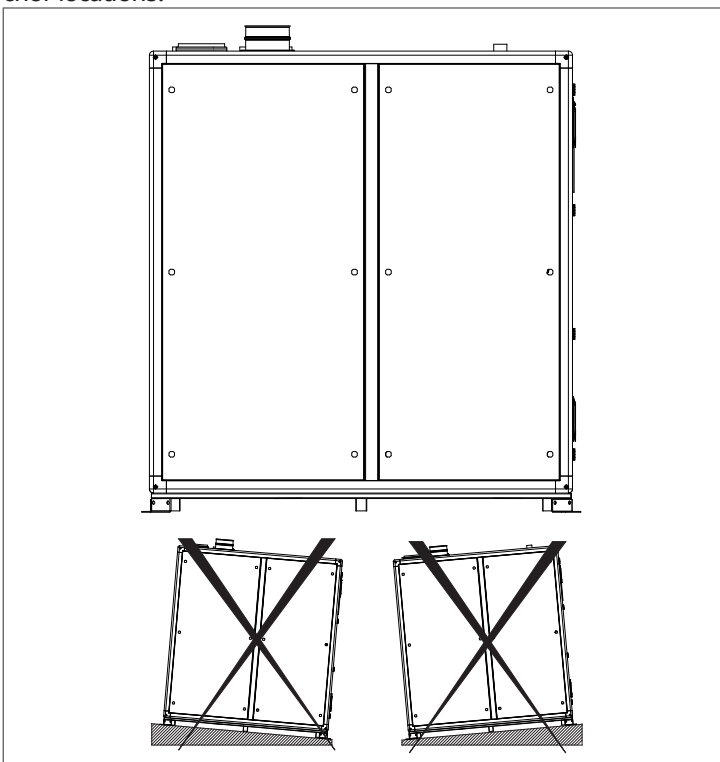

Fig. 5 Array AR 3000 and AR 4000 Installation

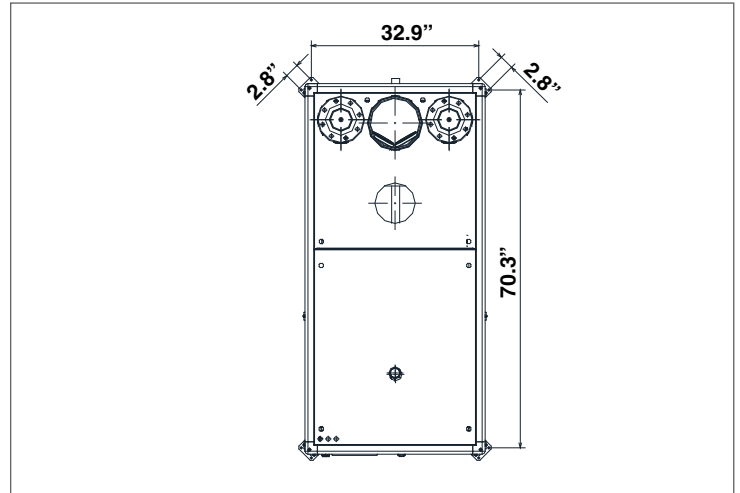

Fig. 6 Array AR 3000 and AR 4000 Anchoring bolts

2.5 Boiler location

- This boiler is suitable for indoor installations.
- To operate properly and safely this boiler requires a continuous supply of air for combustion. Install this boiler in a clean, dry location with adequate air supply.
- Do not locate this boiler in an area where it will be subject to freezing.
- The boiler should be located close to a floor drain in an area where leakage from the appliance or connections will not result in damage to the adjacent area or to lower floors in the structure.
- DO NOT install this appliance in any location where gasoline or flammable vapors are likely to be present.
- DO NOT install this appliance on top of carpet flooring.
- Appliance must be installed on a level floor.
- Maintain required clearances from combustibles surfaces.

2.6 Supply and return piping

The **Array** Boiler utilizes 4" flanges, for both models **AR 3000** and **AR 4000**, for the water system supply and return piping connections. The physical location of the supply and return piping connections is on the top of the unit as shown in Fig. 7.

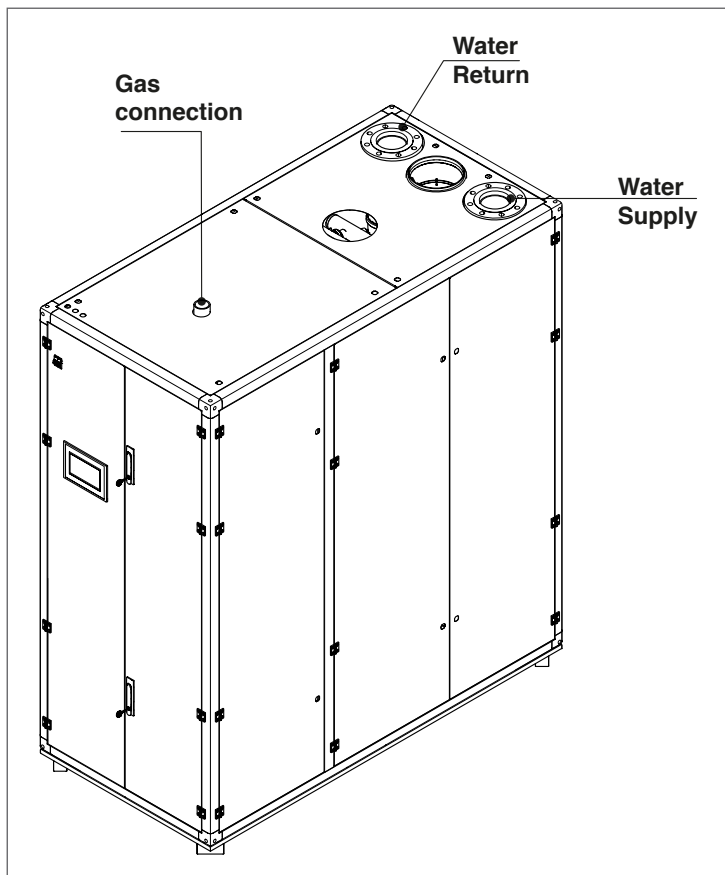

Fig. 7 Array AR 3000 and AR 4000 Connections

Excessive water hardness causing a lime buildup in the stainless steel coils or tubes is not a fault of the appliance and is not covered by warranty. Water hardness must fall within the following limits:

STEEL BOILERS - With furnace power > 500kBTU/h			
		Water used for first filling	Water with system operating
ph		6 - 8	7.5 - 9.5
Hardness	ppm	< 50	< 50
Electrical Conductivity	ppm		< 67
Chlorides	ppm		< 10
Sulphides	ppm		< 10
Nitrides	ppm		< 10
Oxygen in Solution	ppm		
Iron	ppm		< 0.5

- Use only untreated water to fill the system.
- Do not use TSP (tri-sodium phosphate).
- Do not use fill water treated with salt bedding type exchangers (ion exchanger).
- Never introduce non-approved boiler treatment or similar additives.
- Consult a local water treatment specialist for recommendations if any of the above is outside the stated ranges.
- When using oxygen permeable PEX, the system must be separated from the boiler by a heat exchanger.
- A correctly sized and working expansion vessel must be installed.
- Do not exceed the maximum permissible flow rate through the boiler. Excessive flow can cause erosion damage to the heat exchanger.

CAUTION: Before connecting the boiler to the heating system, flush the heating system to remove sediment, flux, dirt, and other foreign matter. The heat exchanger may be damaged by sediment or corrosion.

CAUTION: Do not use cleaning fluids that are not compatible with the boiler materials, including acids (e.g. hydrochloric acid and similar ones) at any concentration.

CAUTION: Introducing fresh water to the system increases the oxygen presence and can cause corrosion of metallic components. Immediately repair any drips or leaks in the system to avoid constant introduction of air into the system.

CAUTION: Excessive fluctuation in pressure changes in the system can cause fatigue and stress on the heat exchanger. This is detrimental to the integrity of the boiler and system components, it is mandatory to maintain a constant operating pressure.

CAUTION: For freeze protection use only propylene glycol, with scale inhibitors, with a maximum volume [concentration] of 50% of glycol. Frost protection and inhibitor level has to be checked annually during the regular scheduled maintenance of the condensing boiler.

A minimum water pressure is required for optimum performance. Minimum water pressure required: 7.25 psi (0.5 bar).

2.7 Low water cutoff

A low water cut off (LWCO) is installed on each boiler.

To check the functionality of LWCO go to the 905PB inner display, access the Settings menu, select Test mode, and then click on LWCO1. On the screen will appear the error "MN: Low Water Cutoff Error".

At this point press the reset button. The error will turn off.

2.8 High limit safety switch

A high limit safety switch is installed on each module of the boiler. To simulate a high limit lockout at 208°F go to the 905PB inner display, access the Settings menu, select Test mode, then click on Max temp.

The control will display "MN: Max. Thermostat Lock Error".

At this point press the reset button on the removable display to restart the module.

2.9 Pressure relief valve installation

ASME rated Pressure Relief Valves are factory installed in each **Array** Boiler. The pressure rating for the relief valves is 75 PSI. The relief valves are installed on each hot water horizontal manifold of the boiler as shown in Fig. 8. The relief valves drain piping must be connected to a nearby floor drain. In multiple unit installations the discharge lines must not be manifolded together.

Each must be individually run to a suitable discharge location.

Relief valves should be manually operated at least once a year.

If a relief valve discharges periodically, this may be due to thermal expansion in a closed water supply system.

Contact the water supplier or local plumbing inspector on how to correct this situation.

Do not plug the relief valve.

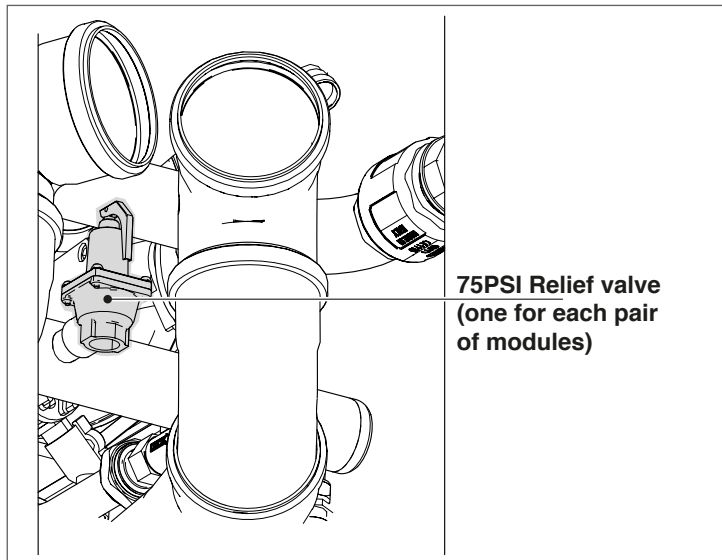

Fig. 8 Pressure Relief Valve Location

2.10 Condensate drain and piping

The **Array** Boiler is designed to condense water vapor from the flue products. Each module of the boiler is equipped with a condensate trap (see Fig. 9), while a syphon collects the condensate of the vertical flue manifold.

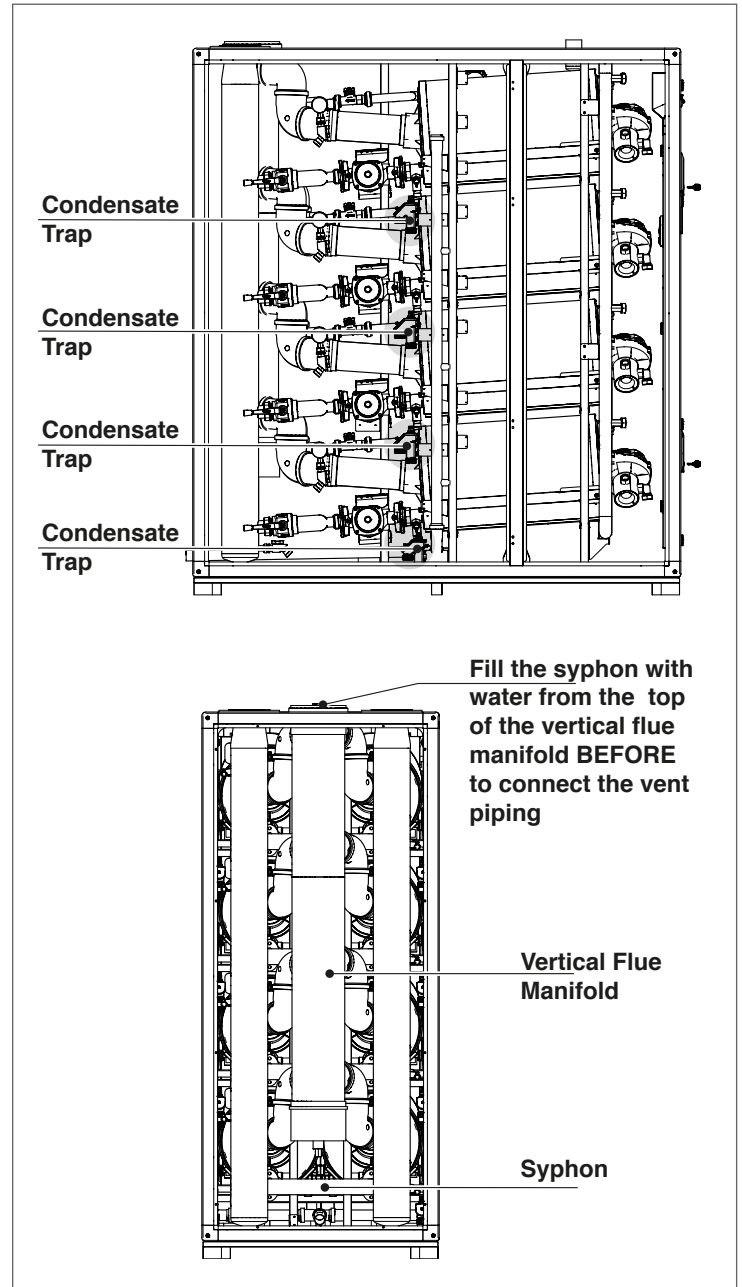

Fig. 9 Condensate Drain System

⚠ WARNING: At the Start-up and after prolonged shutdown of the boiler, the condensate traps and the syphon must be filled with water prior to restart it, otherwise combustion gases will enter the room with a risk of an excessive level of carbon monoxide.

The procedure for filling the traps and syphon with water is shown on the Fig. 10:

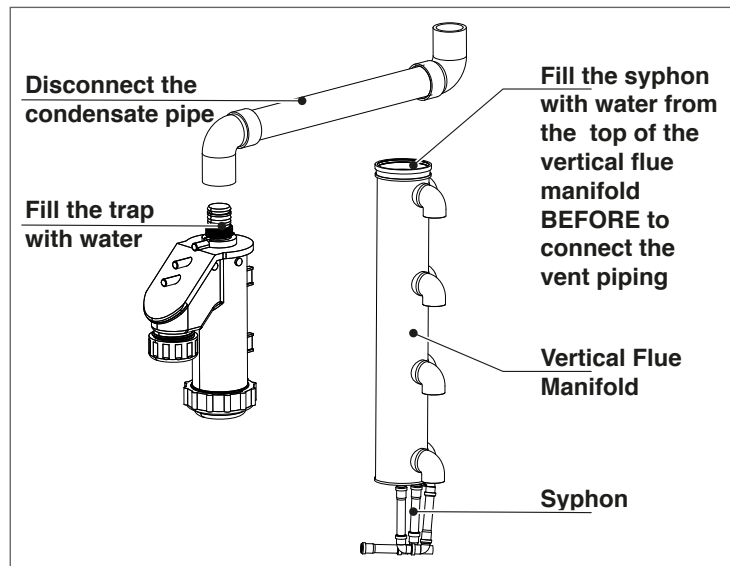

Fig. 10 Water Filling of Condensate System

- The installation must have provisions for suitable drainage or collection of the condensate out of the boiler traps.
- The condensate water shall be discharged at atmospheric pressure, by dripping into a suitable drain, and shall be neutralized prior to draining per local codes.
- The condensate drain tube must pitch away from the boiler (1/4" slope per foot) and must never reduce its diameter downstream.
- Never use copper pipes or of other material not intended for the specific purpose, because the action of condensate will cause a rapid deterioration.
- Check that the condensate drain pipe is adequately sloping towards the discharge point avoiding high points, which can inhibit the flow of condensate. The condensate pipe must be installed in such a way so as to avoid the freezing of the liquid.

⚠ WARNING: Verify condensate disposal / neutralization is in accordance with local, state and federal regulations.

If a floor drain is not available, a condensate pump can be used to remove the condensate to drain. The maximum condensate flow rate is 23.8 GPH for **Array AR 3000** and 31.7 GPH for **Array AR 4000**. The drain line must be removable for routine maintenance.

⚠ CAUTION: Use PVC, CPVC, stainless steel, aluminum or polypropylene for condensate drain piping (Fig. 10). DO NOT use carbon or copper components.

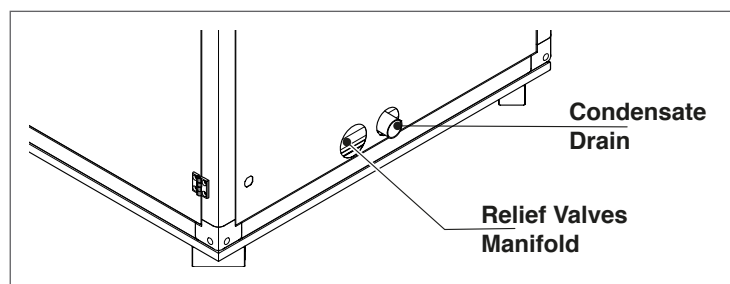

Fig. 11 Condensate Drain and Relief Valves Manifold Locations

2.11 Gas supply piping

Array AR 3000 and **AR 4000** boilers contain a 2 inch NPT gas inlet connection on the top of the unit as shown in Fig. 7.

⚠ WARNING: Never use matches, candles, flames or other sources of ignition to check for gas leaks.

⚠ CAUTION: Many of the soaps used for gas pipe leak testing are corrosive to metals. Therefore, piping must be rinsed thoroughly with clean water after leak checks have been completed.

NOTE: All gas piping must be arranged so that it does not interfere with removal of any covers, inhibit service/maintenance, or restrict access between the unit and walls, or another unit.

- Prior to installation, all pipes should be de-burred and internally cleared of any scale, metal chips or other foreign particles. Do Not install any flexible connectors or unapproved gas fittings. Piping must be supported from the floor, ceiling or walls only and must not be supported by the unit.
- A suitable piping compound, approved for use with natural gas, should be used. Any excess must be wiped off to prevent clogging of components.
- To avoid unit damage when pressure testing gas piping, isolate the unit from the gas supply piping. At no time should the gas pressure applied to the unit exceed 20" W.C. Leak test all external piping thoroughly using a soap and water solution or suitable equivalent. The gas piping used must meet all applicable codes.
- A sediment trap / drip leg must be installed on the gas supply piping.
- Installation of a union at the appliance gas line connection is required for ease of service.

2.11.1 Gas Supply Specifications

The gas supply input specifications to the unit for Natural Gas are as follows:

- The maximum static pressure to the unit must not exceed 20" W.C.
- The gas supply piping and pressure to the unit must be of sufficient capacity to provide 3030 cfh for **AR 3000** and 4040 cfh for **AR 4000**, while maintaining the recommended minimum gas pressure at 8" W.C. for burners operating at maximum capacity.

2.11.2 Manual Gas Shutoff Valve

A manual shut-off valve must be installed in the gas supply line upstream of the boiler. Maximum allowable gas pressure to the boiler is 20" W.C.

2.11.3 External Gas Supply Regulator

An external gas pressure regulator is required on the gas inlet piping under most conditions. Regulators must conform to the following specifications:

- The external natural gas regulator must be capable of regulating
 - a) 100,000 – 3,000,000 BTU/HR for **AR 3000**
 - b) 100,000 – 4,000,000 BTU/HR for **AR 4000**
 of natural gas while maintaining a recommended minimum gas pressure of 8.0" W.C. to the unit.
- A regulator **MUST** be used when gas supply pressure will exceed 20" W.C.

The following are **RIELLO's** recommendations for installation of gas pressure regulator, unless superseded by state and local codes and the regulator manufacturer's specifications:

- Horizontal installation of gas pressure regulators is recommended unless stated otherwise by the regulator manufacturer. Consult the manufacturer for additional recommendations and installation options.
- For all **Array** boilers, when installed horizontally the required distance between the gas pressure regulator and the nearest pipe fitting, elbow or valve is 10 feet.
- When pipe size reduction is required, use only bell reducers.

MASSACHUSETTS INSTALLATIONS ONLY

For Massachusetts installations, a mandatory external gas supply regulator must be installed. The gas supply regulator must be properly vented to outdoors. Consult the local gas utility for detailed requirements concerning venting of the supply gas regulator.

The Commonwealth of Massachusetts prohibits the use of copper tubing for the gas line.

NOTE: It is the responsibility of the customer to source and purchase the appropriate gas regulator as described above.

2.11.4 Gas Type Conversion

The heating unit is factory preset for operating with natural gas. This set-up can be changed using the conversion kits supplied by the manufacturer, on demand.

⚠ DANGER: To prevent risks of personal injury and property damage, this conversion shall only be performed by a trained and certified installer in accordance with the manufacturer's instructions and all applicable codes and requirements of the authority having jurisdiction. If the information in these instructions is not followed exactly, or the installation, adjustment, modification, operation or maintenance is carried out by an unqualified person, a fire, explosion or generation of large amounts of carbon monoxide may result causing property damage, personal injury or loss of life. Before carrying out electrical work, disconnect the appliance from the power supply at the emergency shutoff switch or by disengaging the heating system circuit breaker. Take appropriate measures to prevent accidental reconnection. The installer is responsible for the proper conversion of this appliance. The conversion is not complete until the operation of the converted appliance is checked as specified in these instructions.

The gas-air ratio must always be set on the basis of a CO₂ or O₂ reading taken at maximum nominal output and minimum nominal output using an electronic flue gas analyzer.

SWITCHING FROM NATURAL GAS TO LP

- Close the gas shutoff valve
- Disconnect the electric power supply from the boiler

⚠ WARNING: To avoid electrical shock, it is mandatory to disconnect the boiler from the power supply using a service disconnect external switch.

- Open the front panels
- Unscrew the swivel joint indicated in Fig. 12 to separate the valve from the connection pipe with the fan

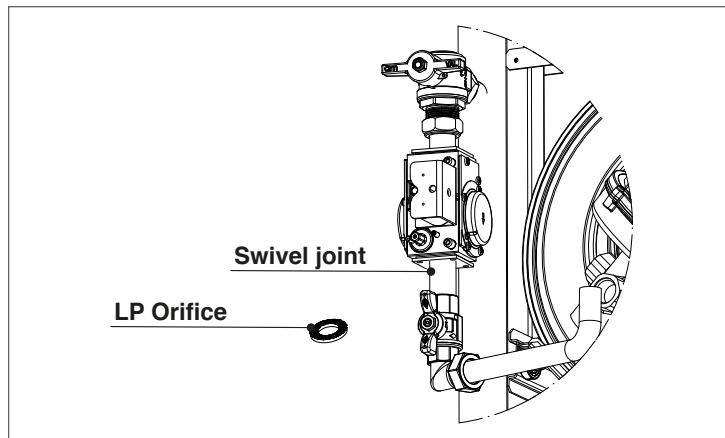

Fig. 12 *Natural Gas to LP Gas Conversion*

- Separating the two components, the hole where the gas passes with its gasket can be accessed
- Place the provided metal orifice (Fig. 12) between the two gaskets (N° on orifice: 9.5)
- Tighten the swivel joint
- Switch the main power supply to ON
- Use the 905PB inner display to enter in the parameter list and change the parameter #95 (Gas Type) from "NG" to "LPG"
- Reopen the gas shut-off valve
- Adjust the CO₂ parameter as explained in next chapter
- Affix the gas type label from the gas conversion kit to the appliance.

2.11.5 Adjusting and setting CO₂ limits

- Insert a combustion analyzer probe into the test port shown in Fig. 13
- Go to the Touchscreen and access the Module screen (as described on "4.3.4 Module Screen" pag. 26) relevant to the module under analysis;
- Press "MODULE TEST" button;
- Press "HIGH POWER" button.

Wait 2 or 3 minutes to reach steady state conditions and record the CO₂ value.

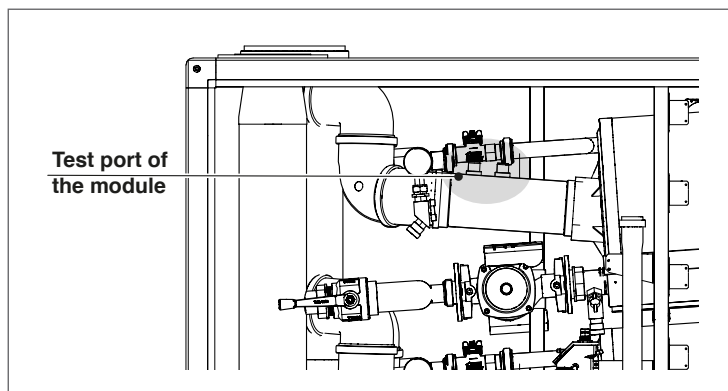

Fig. 13 Test Port for Combustion Analysis (available on each module)

To adjust the CO₂ value at the maximum power turn the screw "A" (rotate counter-clockwise to increase CO₂) shown in Fig. 14, allen type wrench is necessary for this adjustment.

Verify that the value of CO₂ is stable and is within the range indicated in the following table (be careful to make small changes and confirm that the value is stable before making additional adjustment).

Press "LOW POWER": the fan will run at the minimum speed.

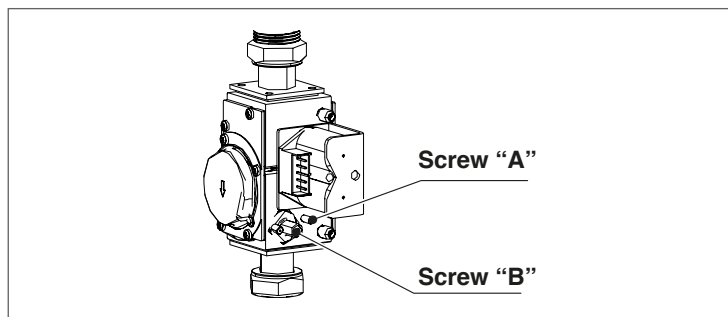

Fig. 14 CO₂ Adjustment

To adjust the CO₂ value at the minimum power turn the screw "B" (rotate clockwise to increase CO₂) shown in Fig. 14.

Verify that the value of CO₂ is stable and is within the range indicated in the following table (be careful to make small changes and confirm that the value is stable before making additional adjustment).

Press "Reset" and the boiler return to the "stand by" mode.

Array Combustion Values		
Gas Type	Max. Fire CO ₂ %	Min. Fire CO ₂ %
Natural Gas	8.5 - 9.5	8.5 - 9.5
LP Gas	10.3 - 10.7	10.3 - 10.7

2.12 AC electrical power wiring

External AC power connections are made to the unit inside the electrical box, located on the front of the unit, inside the front doors. Open the front doors and remove the panel mounted in the upper part of the left front door of the unit as shown in Fig. 15.

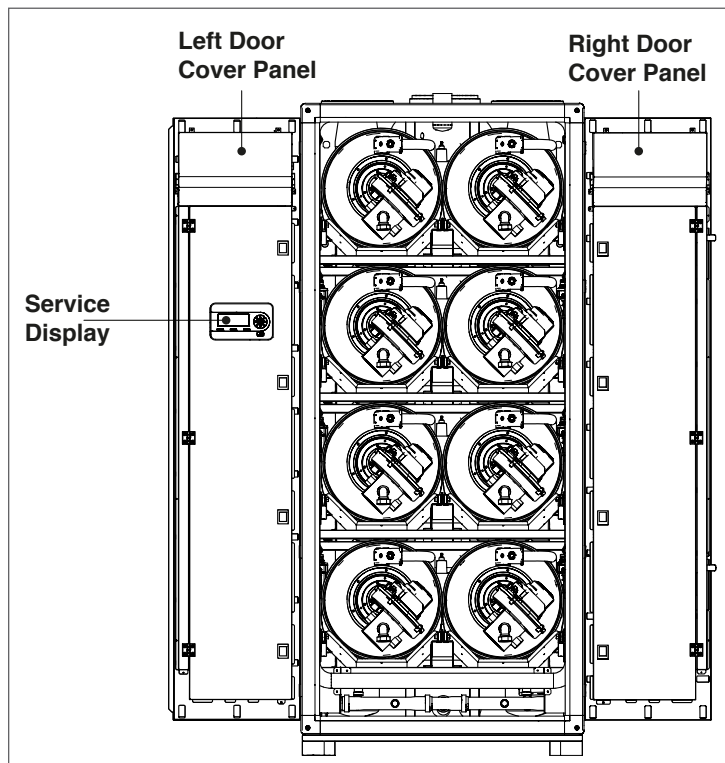

Fig. 15 Front Doors Internal Layout

Loosen the screws of the cover and remove panel to access the internal connections shown in Fig. 16.

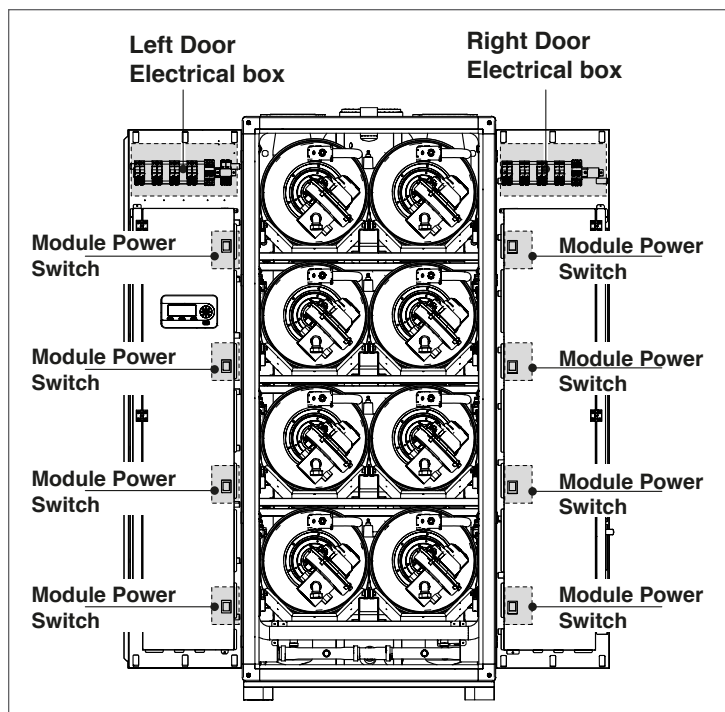

Fig. 16 Front Doors Electrical box

All of the components in the Electrical box are mounted on a DIN rail.

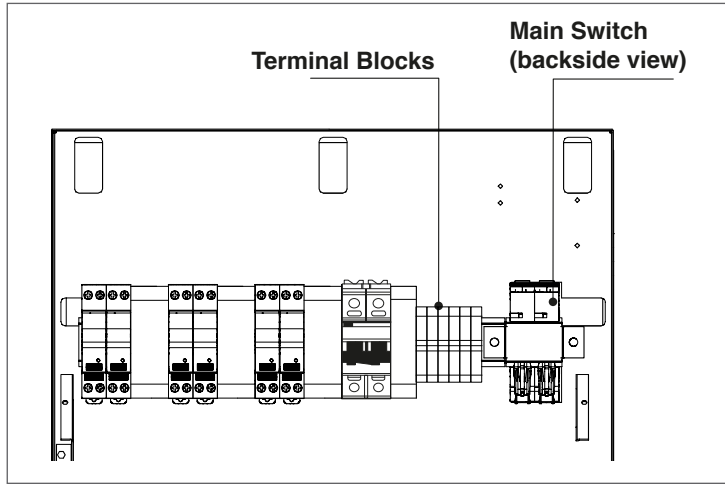

Fig. 17 Left Front Door Electrical components

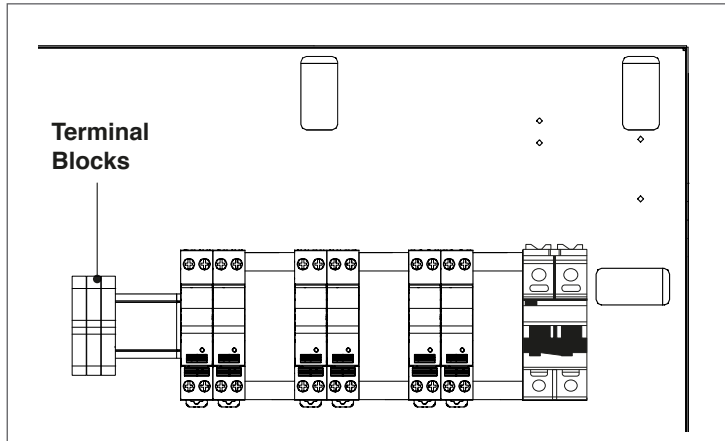

Fig. 18 Right Front Door Electrical components

⚠ WARNING: The main switch shown in Fig. 19 does not remove power from the left door terminal blocks.

NOTE: All electrical conduit and hardware must be installed so that it does not interfere with the removal of any unit covers, inhibit service/maintenance, or prevent access between the unit and walls or another unit.

2.12.1 Electrical Power Requirements

The voltage configuration of **Array AR 3000** and **AR 4000** is as follows:

- 230VAC, Phase-Phase-Neutral, 60 Hz

Each unit must be connected to a dedicated electrical circuit.

NO OTHER DEVICES SHOULD BE ON THE SAME ELECTRICAL CIRCUIT AS THE BOILER.

The Main Circuit two-pole switch is accessible on the front door to quickly and safely disconnect electrical service (except the left door terminal blocks).

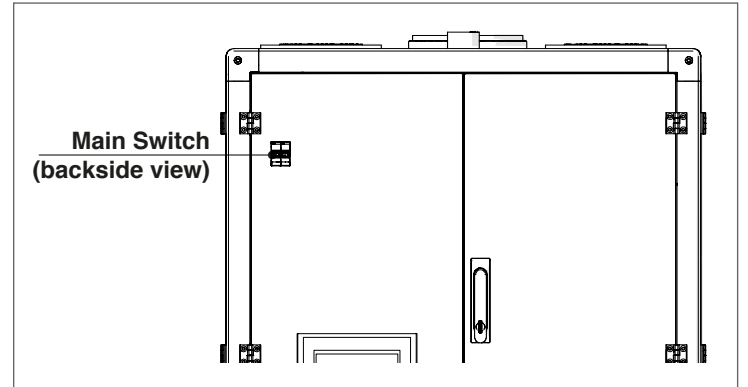

Fig. 19 Main switch

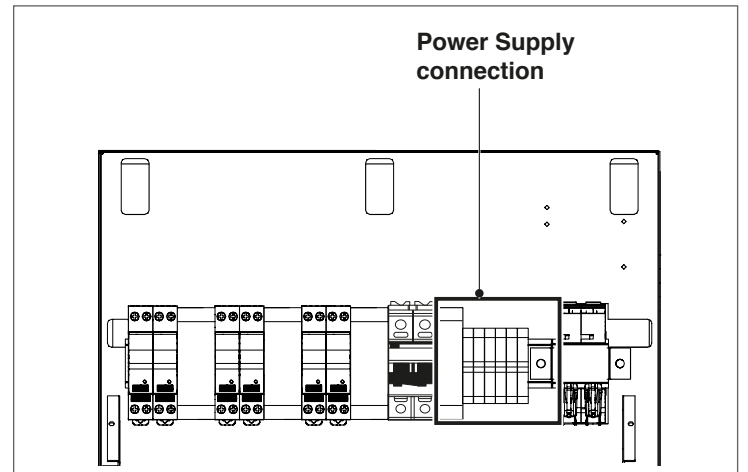

Fig. 20 Power supply connection

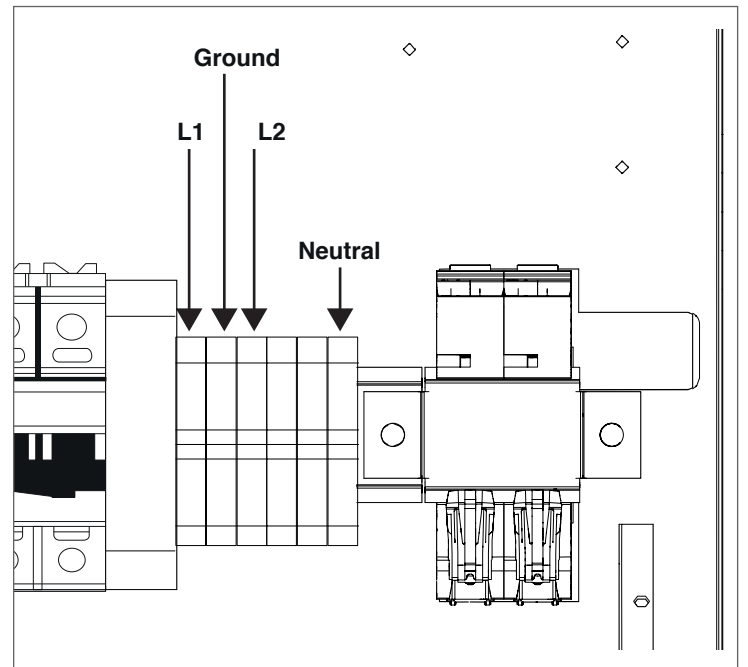

Fig. 21 230VAC Power Supply connection

If an external electrical power source is used, the installed boiler must be electrically bonded to ground in accordance with the requirements of the authority having jurisdiction. In the absence of such requirements, the installation shall conform to National Electrical Code (NEC), ANSI/NFPA 70 and/or the Canadian Electrical Code (CEC) Part I, CSA C22.1 Electrical Code.

2.13 Field control wiring

Each unit is fully wired from the factory with an internal operating control system. No field control wiring is required for normal operation.

However, the control system used with all **Array** boilers does allow for some additional control and monitoring features. Wiring connections for these features are made on the Input / Output (I/O) terminal strips located behind the removable cover on the inner side of the front door of the unit, as shown in Fig. 22.

NOTE: Any electrical load connected to the terminal strip (external pumps, air damper, alarm) must be powered through a relay, not included in the boiler, to be provided and wired by the installer.

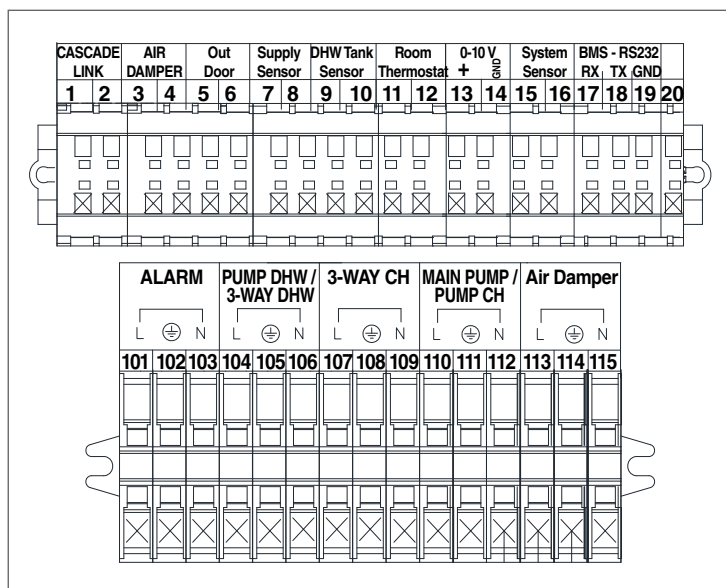

Fig. 22 I/O Terminal Strips

All field wiring is installed from the rear of the panel by routing the wires through one of the openings provided on the sides of the cover panel.

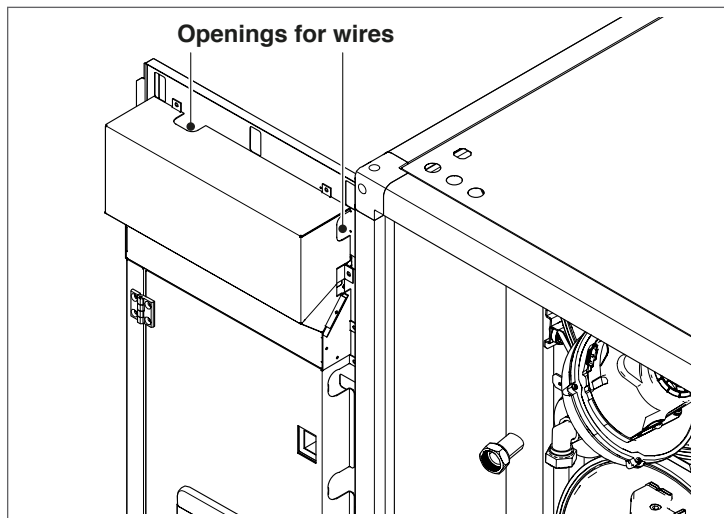

Fig. 23 Opening on the Cover Panel

2.13.1 Room Thermostat Connection (Enable/Disable)

The Room Thermostat (Enable/Disable) terminals (dry contacts) come pre-wired closed (jumped) from the factory. For connecting a room thermostat, the jumper must be removed and the thermostat wires must be connected to terminals 11 and 12, as shown in Fig. 22.

2.13.2 Air Damper

The Air Damper output comes disabled from the factory. For connecting an air damper, the Programmable Output 3 must be set to 10 and the damper wires must be connected to terminals 3 and 4, as shown Fig. 22.

The Air Damper is connected to output J3-6 which is a Triac controlled output.

This output need a minimum load of approx. 10VA to work correctly and the max load must be limited to 50VA at mains voltage. Connection of an external relay to this output to be able to switch a higher load is only possible when an additional resistor or load is added to make sure the minimum load requirements are met.

2.13.3 Outdoor Temperature Sensor

If outdoor temperature sensor is to be used, the outdoor probe needs to be connected to terminals 5 and 6 as shown in Fig. 22. The outdoor probe shall be installed on an outer wall, North or North/East, away from windows, door, and ventilation grids. Never install the probe in a position exposed to the sun. The maximum length is 300' (100 meters), if the cable length exceeds 32' (10 meters) a shielded cable is required and shall be connected to chassis ground.

NOTE: All sensors and low voltage wiring shall not be routed in direct contact or near high voltage power.

2.14 Venting

Array boilers must be vented and supplied with combustion and ventilation air as described in this section.

Installation must comply with local requirements and with the National Fuel Gas Code ANSI Z223.1. **Array** boilers vent and air piping can be installed through the roof or through a sidewall.

Any of the vent/air piping methods covered in this manual can be used. Do not attempt to install the boilers using any other means. Suitable, UL approved, positive pressure, watertight vent materials **MUST** be used for safety and UL certification.

AR 3000 and **AR 4000** boilers can use the following material for venting:

Material	Standard	Maximum Flue Temperature (°F)	Approved Manufacturers
CPVC Schedule 40, 80	ANSI/ASTM F441	194	
Polypropylene	ULC S636	230	Centrotherm Eco Systems (InnoFlue SW)
AL29-4C stainless steel	UL 1738	300+, limited only by rating of seals	

For specific venting components (terminals, fittings), contact the respective vent manufacturer.

⚠ DANGER: It is extremely important to follow these venting instructions carefully. Failure to do so can cause severe personal injury, death or substantial property damage.

⚠ DANGER: Use of cellular core PVC (ASTM F891), cellular core CPVC or Radel® (polyphenosulfone) in venting systems is prohibited.

⚠ WARNING: Do not connect this gas appliance with any other appliance unless approved by manufacturer. Failure to comply with this WARNING could result in the accumulation of carbon monoxide gas which can cause severe personal injury or death

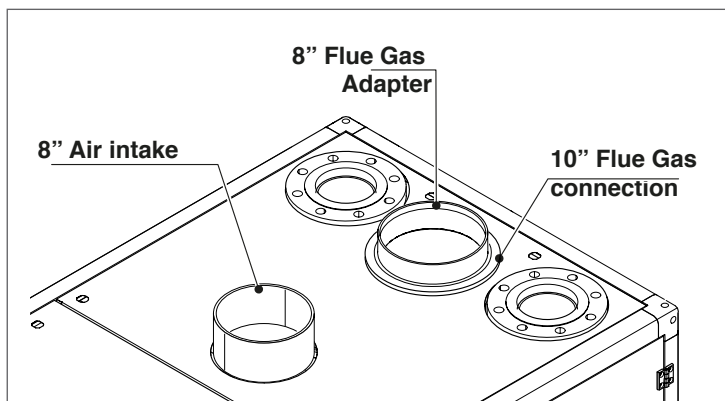

Fig. 24 Combustion Air and Flue Gas Connections

⚠ DANGER: The condensate traps must be filled with water or combustion gases will enter the room with a risk of an excessive level of carbon monoxide.

- Vent connectors serving appliances vented by natural draft shall not be connected to any portion of mechanical draft systems operating under positive pressure.
- Ensure that the flue pipes and seals are not damaged.
- Use only primer and glue compounds approved for use with the vent material used.
- Never install a barometric or a thermally controlled vent damper with this boiler.
- Do not route the flue system piping through or inside another duct that is used for exhausting air or other flue gases.
- The condensate trap must be primed at all times. Failure to do so may allow combustion gases to escape into boiler room.
- The unit is to be used for either direct vent installation or for installation using room air for combustion. When room air is used, it is necessary to provide an adequate opening for the fresh air intake.
- You must use any of the vent/air piping methods shown in this manual.
- Be sure to locate the unit such that the vent and combustion air piping can be routed through the building and properly terminated.
- The boiler / vent installation must be in accordance with Venting of Appliances, of the latest edition of the National Fuel Gas Code, ANSI Z223.1/NFPA or applicable provisions of the local, state and federal building codes.
- All vent pipes must be installed according to the vent manufacturer's instructions.
- The exhaust vent and the combustion air inlet lines must be supported to prevent sagging per the vent manufacturer's instructions.
- Do not mix components from different systems. The vent system could fail, causing leakage of flue products into the living space. Use only approved materials.
- Use of cellular core PVC and CPVC for venting system is not allowed.
- The vent system shall be installed so as to prevent the accumulation of condensate.
- Consult local and state codes pertaining to special building code and fire department requirements. Adhere to national code requirements.
- Observe the listed maximum lengths of vent system, which are boiler model dependent.
- To avoid moisture and frost build-up and to maintain clearances to openings on adjacent structures, 45° and 90° elbows or tees may be attached to the end of the vent termination pipe to direct exhaust plumes away from the adjacent structure. The total allowable vent length, maximum number of elbows and distance to air intake restrictions must be adhered to.
- Due to the high efficiency of the unit it may discharge what looks like white smoke especially when the outside air temperature is cold. This is due to the presence of water vapor, normally present in the exhaust gases.

VENTING CONFIGURATIONS: The following figures show the acceptable piping installation for venting and combustion air.

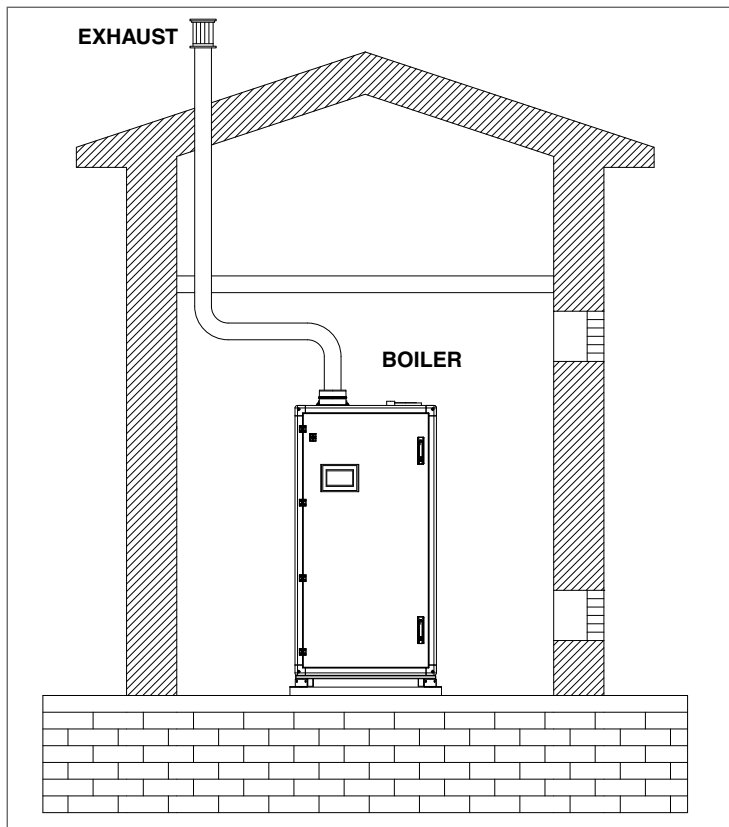

Fig. 25 All Combustion Air from Adjacent Indoor Spaces through indoor Combustion Air Openings

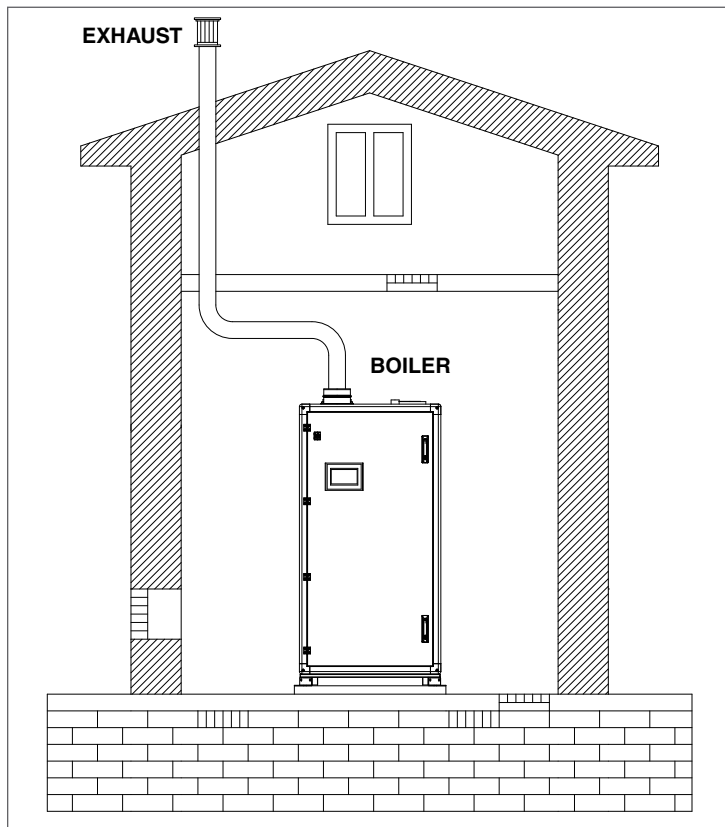

Fig. 27 All Combustion Air From Outdoors - Inlet Air From Ventilated Crawl Space and Outlet Air to Ventilated Attic

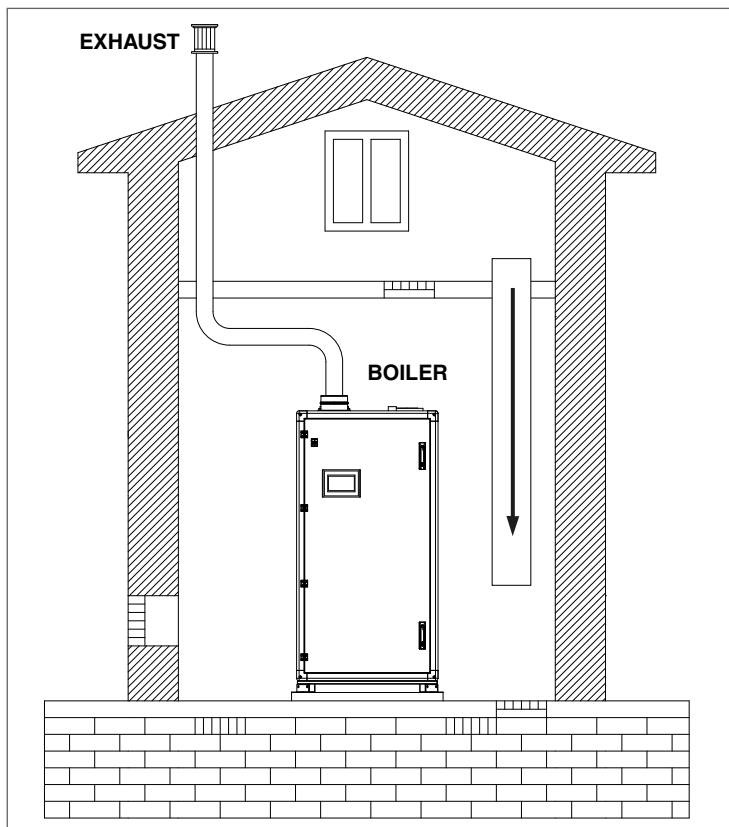

Fig. 26 All Combustion Air from Outdoors - Through Ventilated Attic

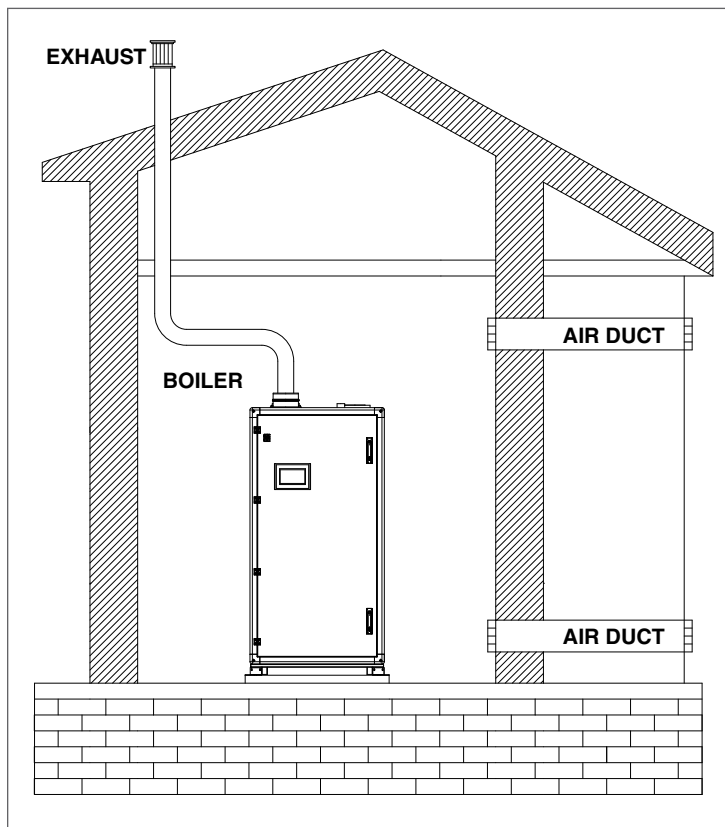

Fig. 28 All Combustion Air from Outdoors through Horizontal Ducts

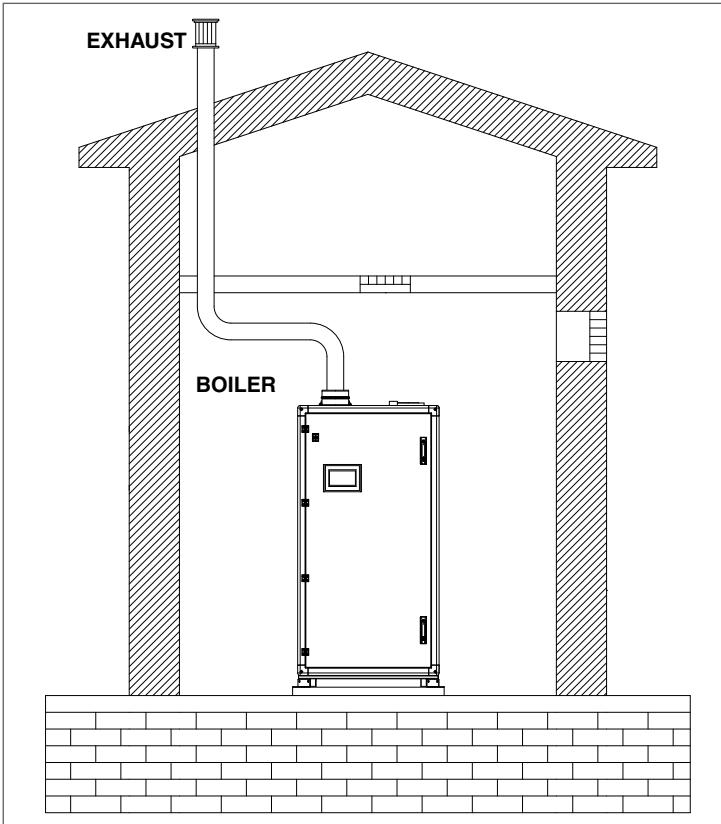

Fig. 29 All Combustion Air from Outdoors through Single Combustion Air Opening

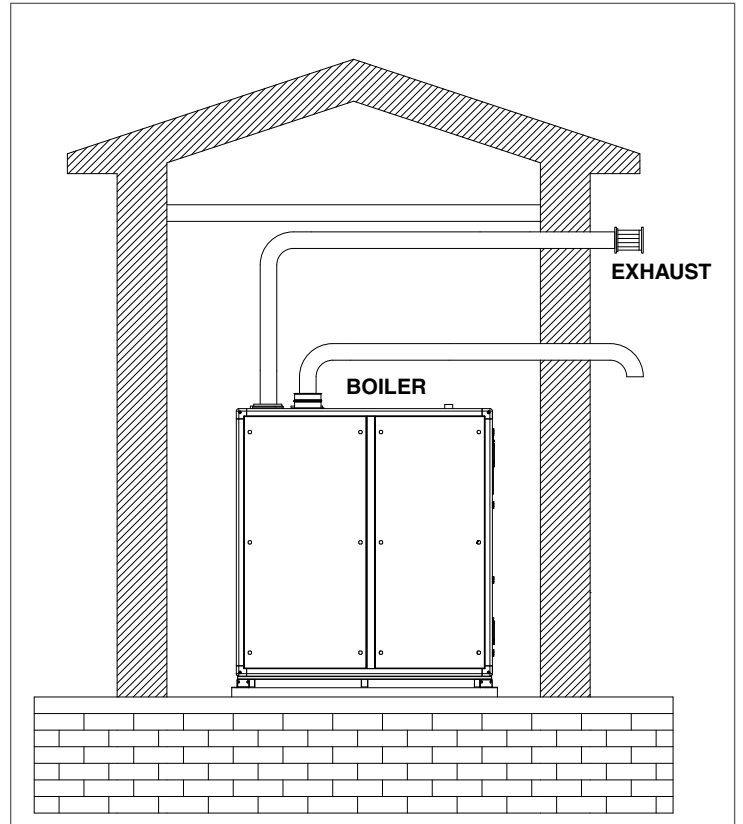

Fig. 31 Sealed Combustion located on same side with Exhaust (horizontal)

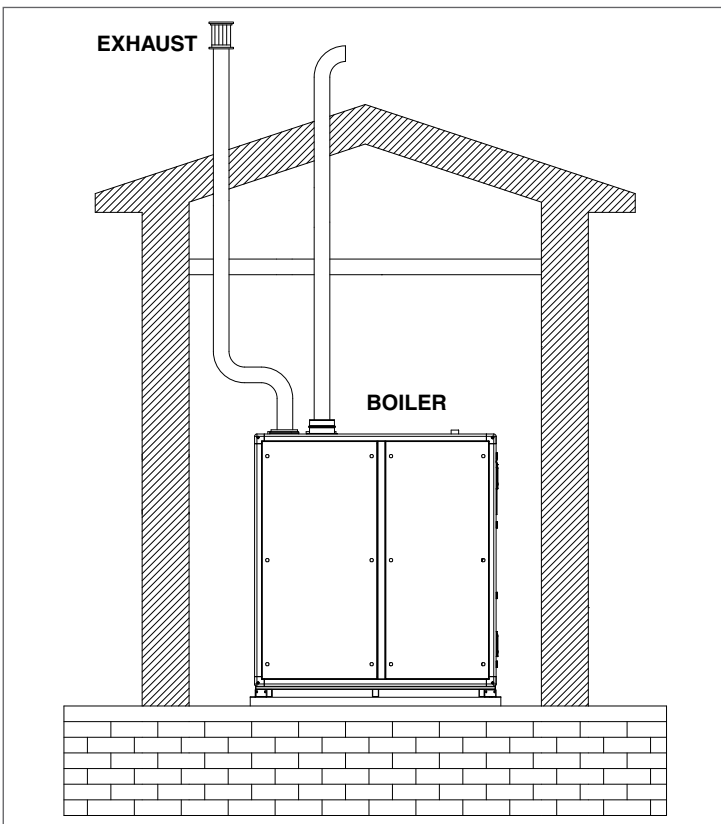

Fig. 30 Sealed Combustion located on same side with Exhaust (vertical)

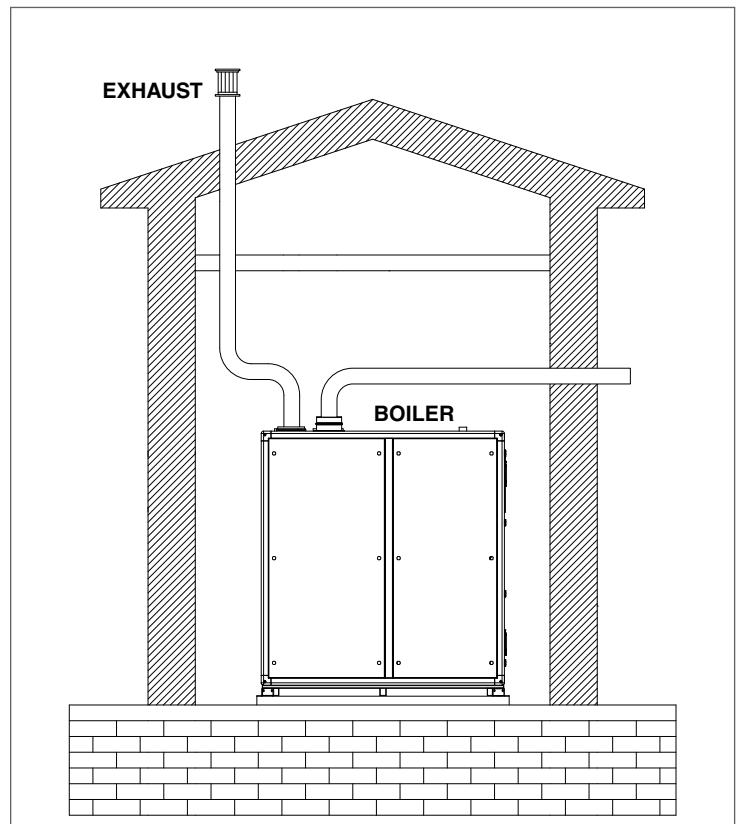

Fig. 32 Sealed Combustion located on side wall

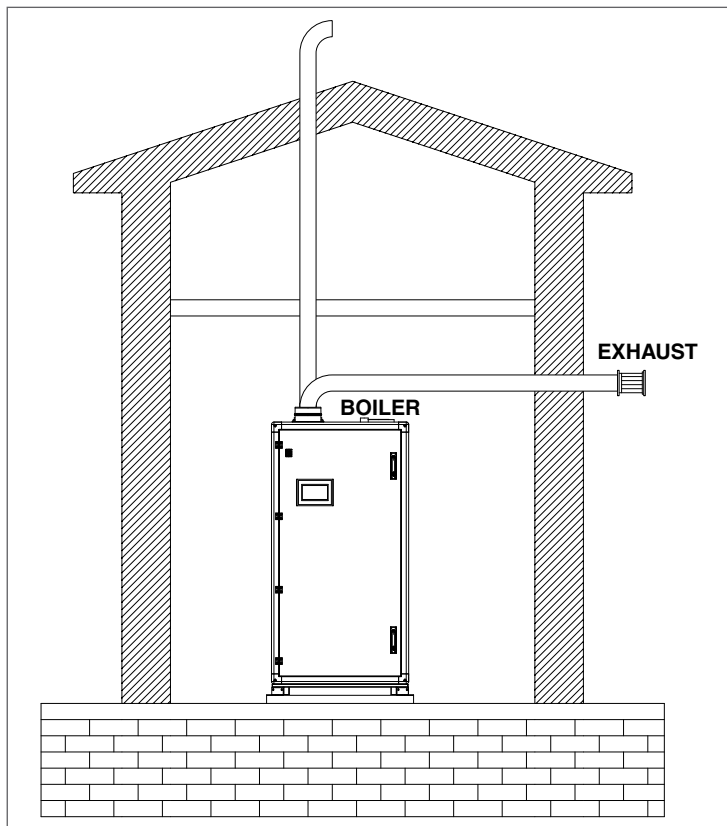

Fig. 33 Exhaust located on side wall

- It is not recommended to terminate vent above any door or window, condensate can freeze causing ice formations.
- Do not use chimney as a raceway if another boiler or fire-place is vented into or through chimney.
- Because the unit is capable of discharging low temperature exhaust gases, the flue must be pitched back towards the unit a minimum of 1/4" per foot to avoid any condensate pooling and to allow for proper drainage.
- While there is a positive flue pressure during operation, the combined pressure drop of vent and combustion air systems must not exceed the following equivalent length:

Model	PIPE SIZE - 8"		PIPE SIZE - 10"	
	MAX. equiv. (m)	MAX. equiv. (ft)	MAX. equiv. (m)	MAX. equiv. (ft)
AR 3000	21	70	30	100
AR 4000	12	40	30	100

Fittings as well as pipe lengths must be calculated as part of the equivalent length, according to the following table:

Model	45° ELBOW - 8"		45° ELBOW - 10"	
	equiv. (m)	equiv. (ft)	equiv. (m)	equiv. (ft)
AR 3000	1.5	5	1.5	5
AR 4000	1.5	5	1.5	5

Model	90° ELBOW - 8"		90° ELBOW - 10"	
	equiv. (m)	equiv. (ft)	equiv. (m)	equiv. (ft)
AR 3000	1.8	6	1.8	6
AR 4000	1.8	6	1.8	6

- For a natural draft installation the draft must not exceed - 0.25" W.C.
- These factors must be planned into the vent installation. If the maximum allowable equivalent lengths of piping are exceeded, the unit will not operate properly or reliably.
- For Massachusetts installations, contact companies able to provide vent systems which conform to all applicable requirements for installations within the Commonwealth of Massachusetts.
- For multiple boilers installation, common venting shall be sized based on the data of Appendix M.

2.15 Combustion air

Air supply is a direct requirement of ANSI 223.1, NFPA-54, CSA B149.1 and local codes. These codes should be consulted before a permanent design is determined.

Array boilers can take combustion air from the space in which are installed, or the combustion air can be ducted directly to the unit. Ventilation air must be provided in either case.

Material	Standard
ABS	ANSI/ASTM D1527
PVC Schedule 40	ANSI/ASTM D1785 or D2665
CPVC Schedule 40	ANSI/ASTM F441
Polypropylene	ULC S636
Single wall galvanised steel	26 gauge

In cold climates it is essential to provide a motorized air inlet damper to control the supply of combustion air and prevent nuisance condensation.

The combustion air must be free of:

- Permanent wave solutions;
- Chlorinated waxes/cleaners;
- Chlorine-based swimming pool chemicals;
- Calcium chloride
- Sodium chloride used for water softening;
- Refrigerant leaks;
- Paint or varnish removers;
- Hydrochloric acid/muriatic acid;
- Cements and glues;
- Antistatic fabric softeners used in clothes dryers;
- Chlorine-type bleaches, detergents, and cleaning solvents found in household laundry rooms;
- Adhesives used to fasten building products and other similar products.

To prevent contamination do not connect the combustion air inlet and exhaust near:

- Dry cleaning/laundry areas and establishments;
- Swimming pools;
- Metal fabrication plants;
- Beauty shops;
- Refrigeration repair shops;
- Photo processing plants;
- Auto body shops;
- Plastic manufacturing plants;
- Furniture refinishing areas and establishments;
- Remodeling areas;
- Garages with workshops

Whenever the environment contains these types of chemicals, combustion air MUST be supplied from a clean area outdoors for the protection and longevity of the equipment and warranty validation. The more common methods of combustion air supply are outlined in the following sections.

2.15.1 Combustion air from outside the building

Air supplied from outside the building must be provided through two permanent openings. For each unit these two openings must have a free area of not less than one square inch for each 4000 BTUs input of the equipment or 750 square inches of free area. The free area must take into account restrictions such as louvers and bird screens.

2.15.2 Combustion air from inside the building

When combustion air is provided from within the building, it must be supplied through two permanent openings in an interior wall. Each opening must have a free area of not less than one square inch per 1000 BTUH of total input or 3000 square inches of free area. The free area must take into account any restrictions, such as louvers.

2.15.3 Ducted combustion air

For ducted combustion air installations, the air ductwork must then be attached directly to the air inlet connection on the sheet metal enclosure. In a ducted combustion air application, the combustion air ducting pressure losses must be taken into account when calculating the total maximum allowable venting run.

For additional details, see "Appendix N - Exhaust terminals and Air inlet Clearances".

3 COMMISSIONING

3.1 Introduction

Before starting the boiler, the user must be correctly instructed by the installer, on how to operate the heater, in particular:

- Make sure that the user understands that combustion air and ventilation openings must not be restricted, closed, or modified in any way.
- Make sure that the user is informed of all the special measures to be taken for combustion air inlet and discharging flue gases, and that these must not be modified in any way.
- Make sure that the user keeps this manual and all other documentation included with the boiler.
- Make sure that the user understands never to tamper with gas control settings and the risk of CO poisoning should an unauthorized individual do so.
- Make sure that the user knows how to adjust temperatures and controls.

⚠ WARNING: Do not attempt to dry fire the unit. Starting the unit without a full water level can seriously damage the unit and may result in injury to personnel or property damage. This situation will void any warranty.

⚠ CAUTION: All of the installation procedures in "Installation" pag. 6 must be completed before attempting to start the unit.

3.2 Filling the condensate system

The condensate system must be filled with water according to the Section 2.9.

⚠ WARNING: At the Start-up and after prolonged shutdown of the boiler, the condensate traps and the syphon must be filled with water prior to restart it, otherwise combustion gases will enter the room with a risk of an excessive level of carbon monoxide.

3.3 Filling the boiler heating system

To fill the heating system, proceed as follows:

- Open any automatic air vents in the heating system.
- Open the fill valve and proceed to fill the heating system and boiler until the pressure gauge (shown on Fig. 41), reads the pressure for which the heating system is sized. The heating system water pressure must be higher than 7.5 PSI.
- Check that there is no water leaking from the fittings. If there is, the leaks must be repaired.
- Check the pressure gauge during the purging process. If the pressure has dropped, re-open the fill valve to bring the pressure back to the desired value.

3.4 Warnings concerning the gas supply

When starting up the unit for the first time the following must be checked:

- That the unit is supplied with the type of fuel that it is configured to use.
- That the gas supply system is provided with all the safety devices and controls required under current national and local codes.
- That the vent and combustion air terminals are properly connected and free from any blockages.
- That the condensate drain tube is properly connected.

3.4.1 Confirming the Unit's Gas Type

The type of gas and the gas supply pressure that the unit is set up for is listed on the rating label. The **Array** Series boilers can operate using one of the following two gases:

NATURAL GAS

- Maximum supply pressure = 20" W.C. (50.0 mbar).
- Minimum supply pressure = 3.5" W.C. (8.7 mbar).

PROPANE (LP) GAS

- Maximum supply pressure = 20" W.C. (50.0 mbar).
- Minimum supply pressure = 8" W.C. (19.9 mbar).

3.4.2 Gas Type Conversion

If the gas available at the installation site is not the type the boiler is configured to use, the boiler must be converted. Special conversion kits are available for this purpose inside the boiler. The gas conversion procedure may be found in Section "2.11.4 Gas Type Conversion" pag. 12. Conversion must be carried out by a qualified technician.

3.5 Boiler startup procedure

To start the boiler, do the following:

- Open the manual gas shut off valve (Fig. 1).
- Turn ON the main power switch (Fig. 19).
- Push all Module power switches to ON (Fig. 16).
- To help removing the air from the hydraulic circuit, the De-airing function can be started for each module. When activated, the "De-Air" sequence starts at every power ON and consists of a controlled cycling of the pumps OFF and ON that takes 14 minutes, during which no demand will be served. If the water pressure is too low and the water pressure switch is in error, the sequence will be suspended until the pressure switch is ON again. This function can be started through the Service display, connecting it to each module using the connection cable mentioned at section "Unpacking" pag. 6, switching the De_Air_Config parameter from 0 to 1. More details are available on the Control System Manual.
- Check/Modify the parameter (*) Number of Units. It must match the number of modules of the boiler (6 for AR 3000 and 8 for AR 4000). By default the number of expected modules is 8. Follow the path below on the Service display: *Menu->Settings->Boiler Settings->Module Cascade Settings->(*) Number of Units*
- The Touchscreen Control Panel will switch on. The Splash/Stand-by screen consists of the **RIELLO** logo:



Fig. 34 Touchscreen Control Panel Splash/Stand-by screen

By touching the logo, the Cascade screen will be accessed:

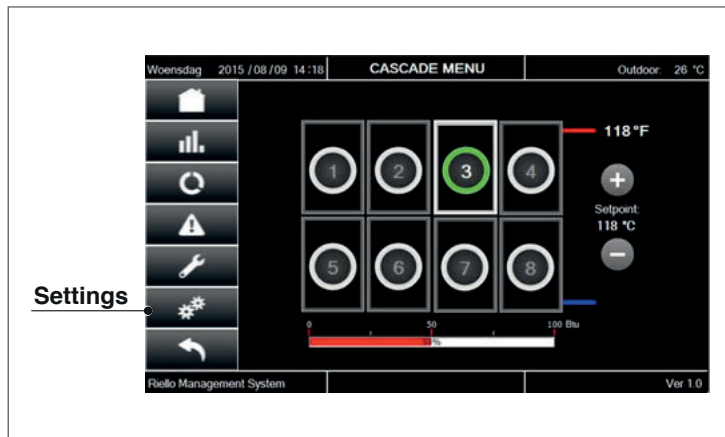

Fig. 35 Cascade Screen

- Pushing the Settings button, the Settings screen will show up:

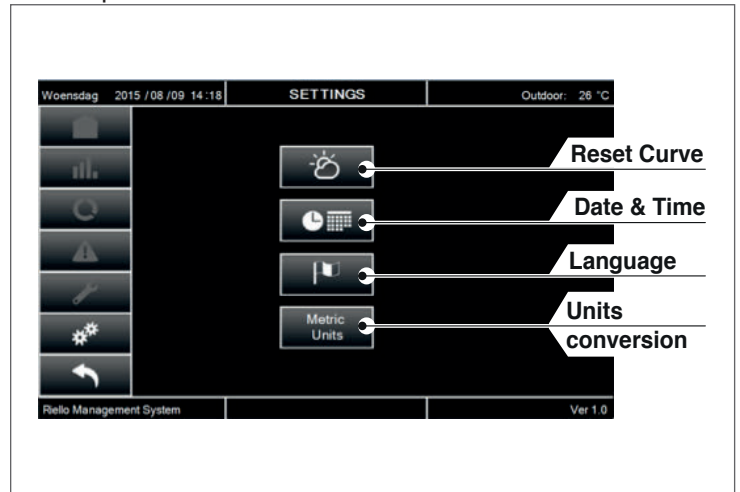

Fig. 36 Settings screen

- Date and Time can be adjusted through the screen below:

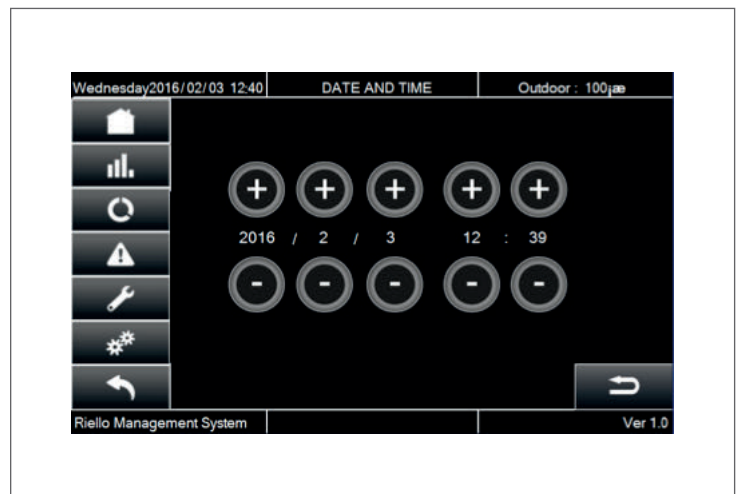

Fig. 37 Date & Time screen

- After the Date & Time setting, if an outdoor probe is connected, the Reset Curve screen must be accessed (through the Settings screen) to set the curve parameters:

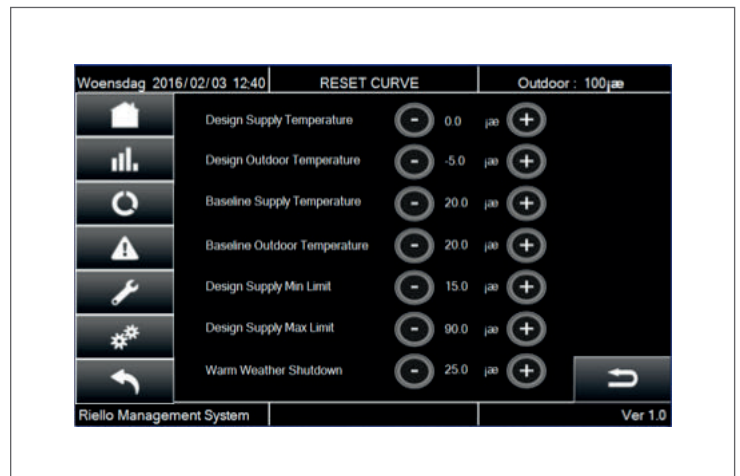

Fig. 38 Reset Curve screen

Adjusting the parameters on that screen, the reset curve below will modify shape and slope to meet the needs of the specific application.

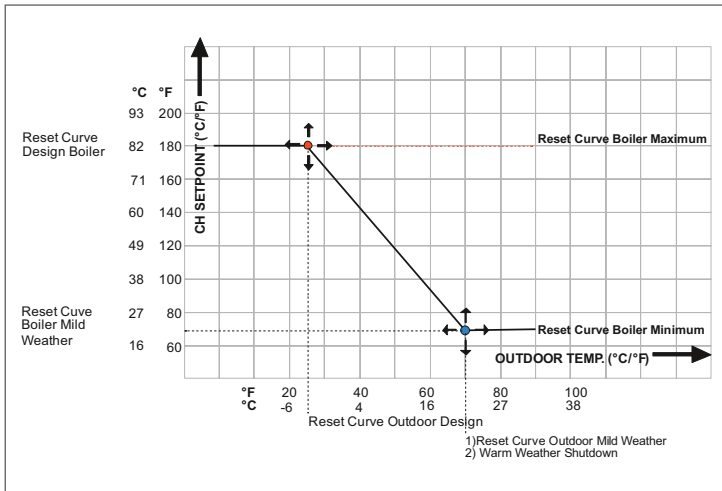

Fig. 39 Reset Curve

- The boiler will fire only when there is a call for heat and the heating temperature setting is higher than the actual supply temperature. Hold buttons "+" or "-" on the Cascade screen (Fig. 46) to select the desired heating temperature. If the external temperature sensor is connected (see Section "2.13.3 Outdoor Temperature Sensor" pag. 15), check that the calculated temperature is higher than the actual boiler temperature and that the outdoor temperature is lower than "warm weather shut down" temperature.
- The boiler CH setpoint can be controlled by an analog input signal provided by a remote means such as a Building Management System or a system controller. The analog input 0-10 VDC, is used to adjust the boiler setpoint between the CH_Setpoint_Min and the CH_Setpoint_Max settings (Figure 35). To enable this operation mode, the parameter CH mode must be set to 4 (see **Array** Control System Manual for accessing the parameter list).

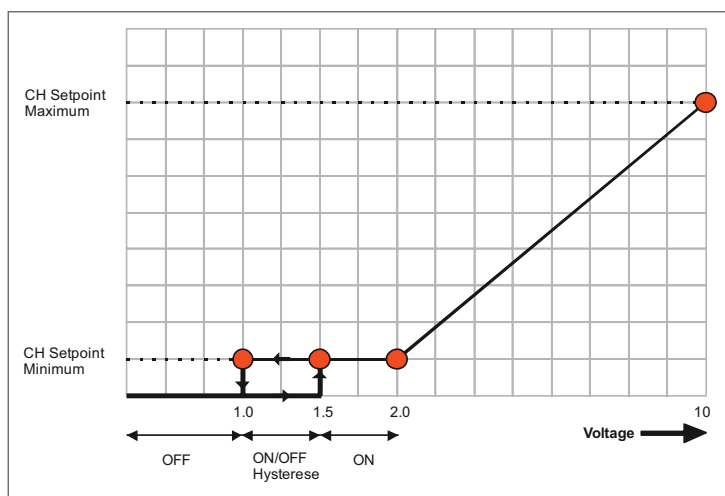

Fig. 40 10VDC Control mode

The CH setpoint Min and CH setpoint Max parameters can be adjusted to provide the desired temperature adjustment band. A heat request will be generated by an input of 1.5 volts or higher.

The setpoint modulation will occur between 2 and 9 volts. The request for heat will be removed when the voltage drops below 1 volt.

All other safety and control functions associated with the boiler will react normally to adverse condition and override control of the analog signal to prevent an upset condition.

3.5.1 Minimum Water Flow (Heat Exchanger Protection)

This unit is self-protected against low water flow. A flow meter continuously monitors the water flow to each module. If the water flow decreases below the minimum stated, the burner automatically shuts off.

3.5.2 Heating System Pressure Test

If the pressure inside the heating circuit falls below the minimum pressure for the system (7.5 PSI), the appliance switches off and the 905PB inner display shows "Low water pressure" to indicate that it is necessary to restore the correct pressure.

Open the filling valve and check the pressure on the temperature/pressure gauge of Fig. 41.

The error will disappear when the pressure is back at the right value. To prevent accidental relief valve openings, fill the heating circuit slowly.

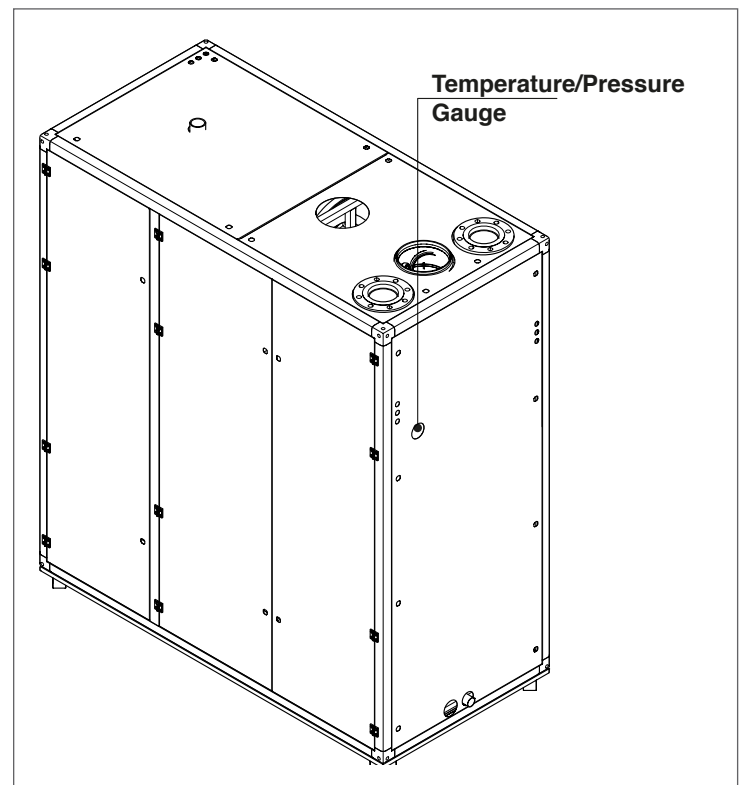

Fig. 41 Temperature/Pressure Gauge location

3.6 Boilers' cascade installation and start-up

Appendix L shows an example of Array boilers installed in a cascade of three units. The built-in control system is capable to manage up to 8 boilers as a single, coordinated heating system. The logical scheme is:

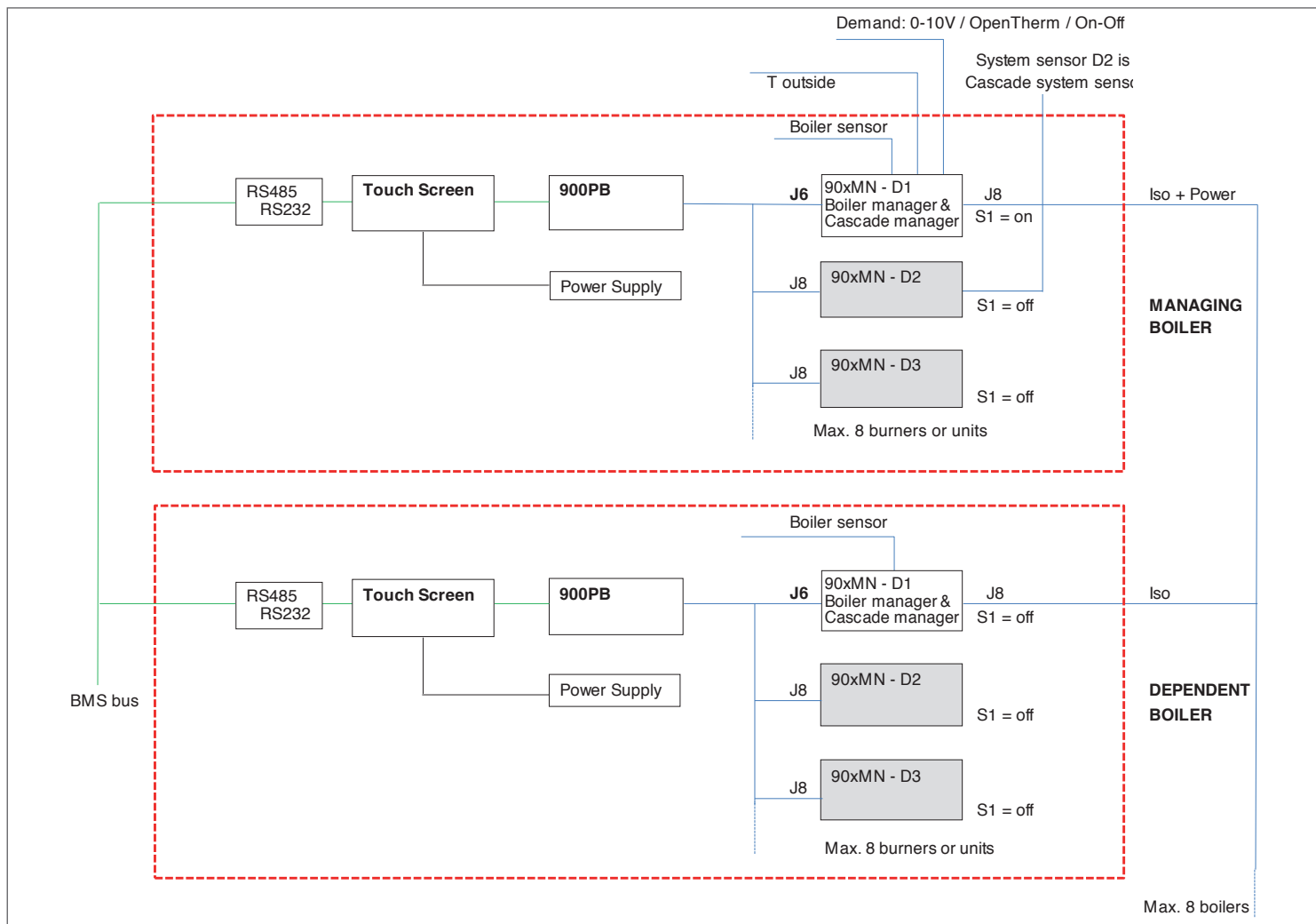

Fig. 42 Cascade installation scheme

After the electrical wiring of the Managing controllers of each boiler of the cascade (through the "Cascade link" connections on the Low voltage terminal strips), the following steps must be done:

3.6.1 Boilers Cascade: Set Boiler Address

Assign the Boiler Address in the Managing boards of each boiler of the cascade, following the path below on the Service display:

Menu->Setting->Boiler Settings->Boiler Cascade Settings->(73) Boiler Address

BOILER	(73) Boiler Address	BOILER	(73) Boiler Address
Managing	Managing	Dependent 4	Dep. 4
Dependent 1	Dep. 1	Dependent 5	Dep. 5
Dependent 2	Dep. 2	Dependent 6	Dep. 6
Dependent 3	Dep. 3	Dependent 7	Dep. 7

3.6.2 Boilers Cascade: Set Power switch S1

On the Managing controller of the Cascade Managing boiler, the Power Switch S1 must be in ON position (see picture below). The S1 switch must be in OFF position on all other controllers of the boilers in the cascade.

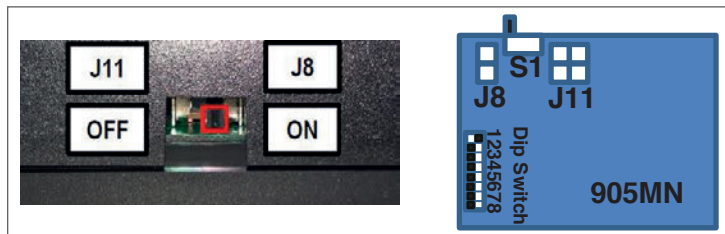

Fig. 43 Set Power switch S1

4 OPERATION

4.1 Introduction

The information in this Chapter provides a guide to the operation of the **Array** Boiler using the Control Panel mounted on the front of the unit. It is imperative that the initial startup of this unit be performed by factory trained personnel. Operation prior to initial startup by factory trained personnel may void the equipment warranty. In addition, the following WARNINGS and CAUTIONS must be observed at all times.

⚠ WARNING: Electrical voltages in this system include 120 and 24 volts AC. It must be serviced only by factory certified service technicians.

⚠ WARNING: Do not attempt to dry fire the unit. Starting the unit without a full water level can seriously damage the unit and may result in injury to personnel or property damage. This situation will void any warranty.

⚠ CAUTION: All of the installation procedures in Chapter "2 Installation" pag. 6 must be completed before attempting to start the unit.

4.2 Control panel description

All **Array** Series Boilers utilize the Touchscreen Control Panel shown in Fig. 45. This Touchscreen panel contains the basic controls for monitoring the boiler. All other controls, indicators and displays necessary to operate, adjust and troubleshoot the boiler are available on the 905PB inner display shown in Fig. 15. Additional information on these items is provided in the individual operating procedures and menu descriptions provided in this Chapter.

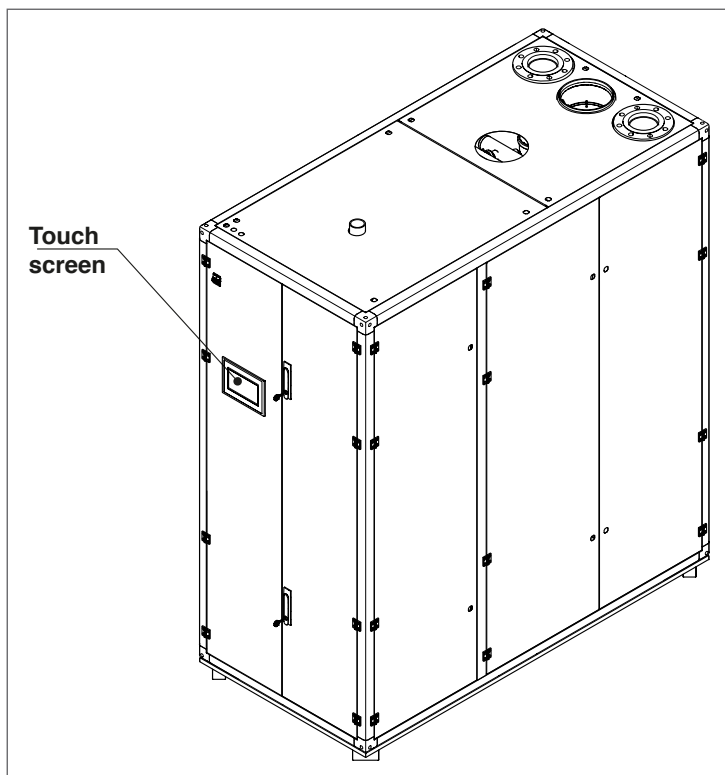

Fig. 44 Touchscreen Control Panel

4.3 Touchscreen control panel menus

The Touchscreen Control Panel incorporates a menu structure which permits the operator to monitor and set up (basic settings only) the unit. The menu structure consists of four major screens and four secondary ones.

4.3.1 Riello Screen



Fig. 45 Riello Screen

The **RIELLO** logo is the entry point of the Control System. Just touching it, the system moves to the first operating screen, the Cascade one.

4.3.2 Cascade Screen

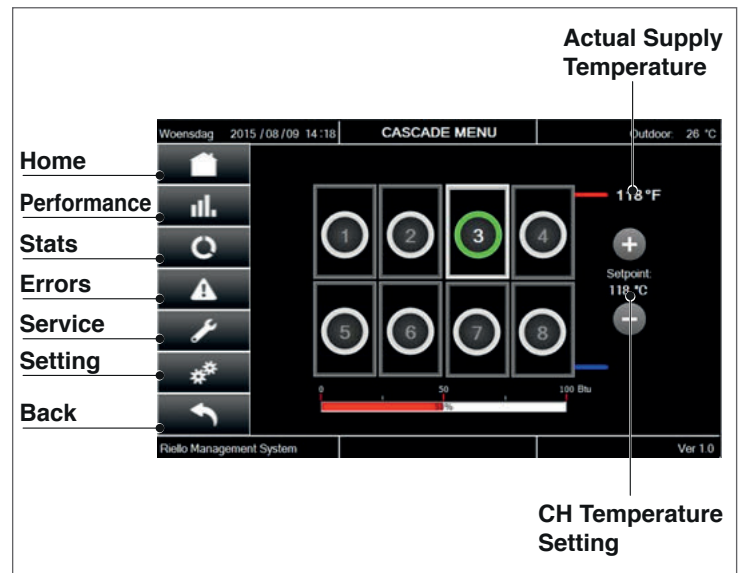

Fig. 46 Cascade Screen

The Cascade screen shows the current configuration of the plant, made by one or more cascaded boilers.

- Through this screen, the following actions can be done:
- Adjust the temperature setpoint using the "+" and "-" buttons;
 - Access the Boiler screen of the desired boiler, just touching it on the screen;

- **Home button:** move back to the **RIELLO** screen;
- **Performance button:** move to the Performance screen of the cascade;
- **Stats button:** not active;
- **Errors button:** move to the Errors screen;
- **Service button:** move to Service screen;
- **Settings button:** move to Settings screen;
- **Back button:** move to the previous screen.

4.3.3 Boiler Screen

Through this screen, the following actions can be done:

- Check the status of the modules (ON, OFF, in error);
- See the current supply temperature at the boiler header;
- Access the Module screen of the desired module, just touching it on the screen;

Use the side buttons to perform the actions listed below:

- **Home button:** move back to the **RIELLO** screen;
- **Performance button:** move to the Performance screen of the boiler;
- **Stats button:** not active;
- **Errors button:** move to the Errors screen;
- **Service button:** move to Service screen;
- **LWCO TEST button:** carry out the Low Water Cut Off functionality test;
- **Back button:** move to the previous screen.

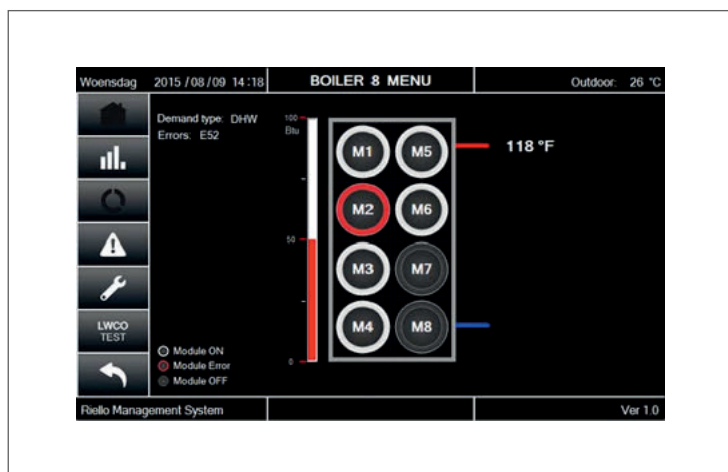

Fig. 47 Boiler screen

4.3.4 Module Screen

Through this screen, the following actions can be done:

- See the current value of many parameters: water supply&return temperature, flue temperature, water flowrate, fan speed, ionization current, burner and pump status, any error ON or service required;

Use the side buttons to perform the actions listed below:

- **Home button:** move back to the **RIELLO** screen;
- **Performance button:** move to the Performance screen of the module;
- **Stats button:** not active;
- **Errors button:** move to the Errors screen;
- **Service button:** move to Service screen;
- **MODULE TEST button:** move to the Module test screen;
- **Reset button:** clean any Locking error relevant to the module;
- **Back button:** move to the previous screen.

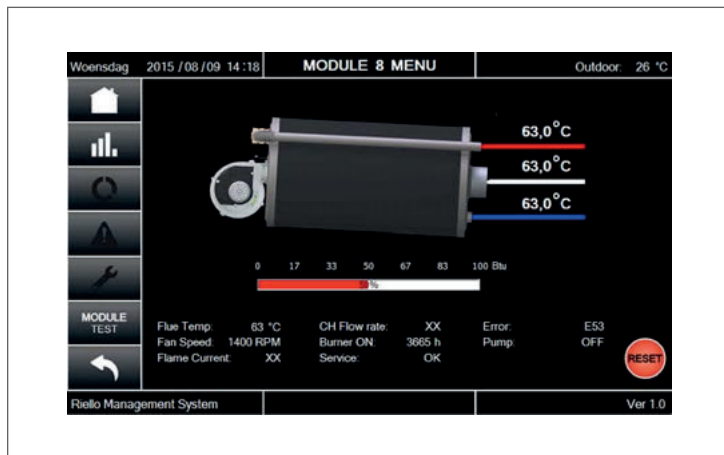

Fig. 48 Module screen

IMPORTANT: When resetting a Locking error of the Managing module, the whole boiler will be switched OFF and then re-started.

4.3.5 Performance Screen

The Control system is able to show the “real time” performance of the plant, starting from 12 hours before the current time. The screen shows different information according to the context.

The Cascade Performance screen includes the trend of:

- Current power input;
- Targeted temperature setpoint;
- Current supply temperature.

The Boiler Performance screen includes the trend of:

- Current power input;
- Targeted temperature setpoint;
- Current supply temperature.

The Module Performance screen includes the trend of:

- Current power input;
- Targeted temperature setpoint;
- Current supply temperature.

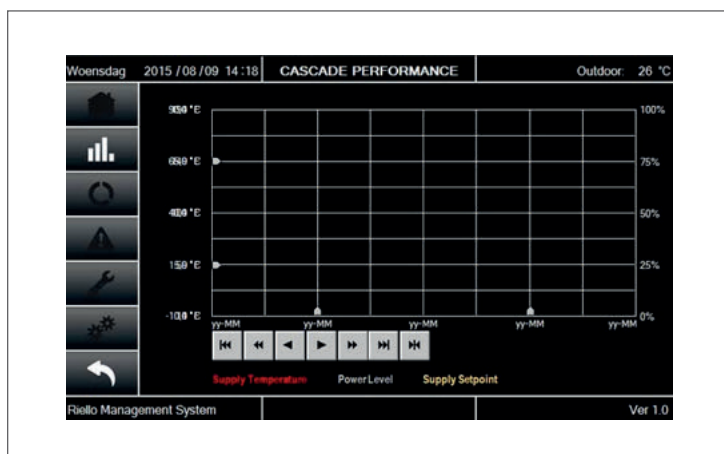

Fig. 49 Performance screen

4.3.6 Error Screen

For each boiler, the Error screen shows the list of the last 40 errors occurred on its own modules.

The errors are listed in chronological order, under two categories: Blocking errors and Locking errors.

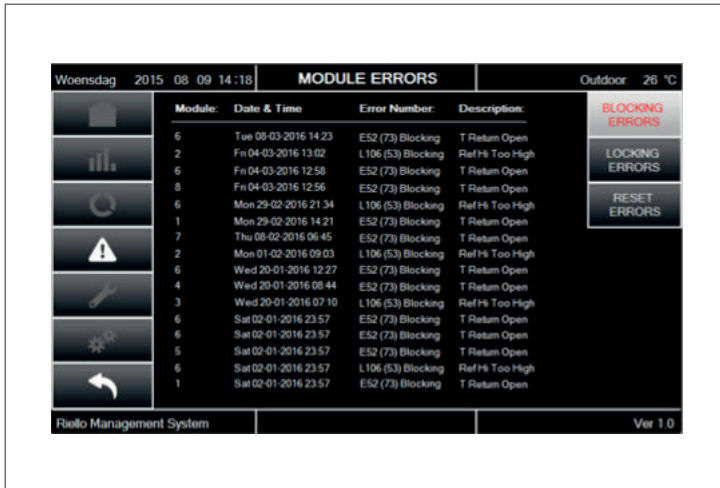

Fig. 50 Error screen

4.3.7 Service Screen

The Service screen shows the main parameters of the Service Reminder function.

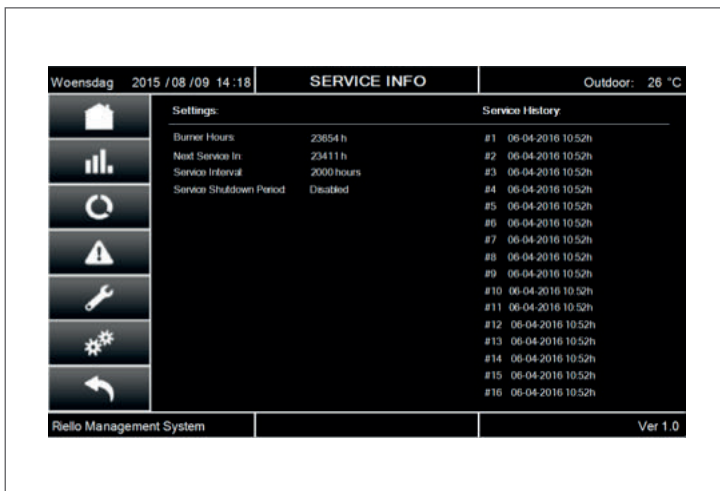

Fig. 51 Service screen

The **Service Reminder** will remind the owner/user of the appliance to service the appliance at a specified **Service_Interval** (factory setting).

When service is not done within the specified time, a service reminder will be shown on the screen, alternating with the normal status display.

The **Service_Interval** can be set as the number of burn hours or the number of operational (appliance is powered) hours.

This can be done by setting the **Service_Hour_Counter** (factory) parameter.

When the Service Reminder is active, the time before service is actually done is logged by the 900PB (in hours). This time is called the Service Overdue time. With this log the factory can read back

how long service was overdue on the system/appliance which can be useful when handling warranty claims.

A maximum of 15 Service moments can be logged by the 900PB, when the log is full it will overwrite the oldest log entry.

Each time the Service Reminder is being reset, a new service moment is counted and the Service Overdue counter will be stored in the log/history.

There are two types of service reminders: **(Normal) Service Reminder** and **Service Shutdown**.

The **(normal) Service Reminder** will only show the service reminder message on the screen and will log how many hours the service is overdue, and the appliance will remain fully operational.

The **Service Shutdown** has the same functionality as the Service Reminder but will shut-down the appliance after the specified **Service_Shutdown_Period** (factory setting) after the service reminder became active (message is displayed).

The owner/user has a warning before the appliance will actually shutdown. Re-enabling the appliance is only possible by resetting the Service Reminder (Shutdown) which is done by the installer.

4.3.8 Module Test Screen

This screen is designed to support the installer and service activities. When pushing the Module Test button on Module screen, a new set of buttons appears on the left side of the screen.

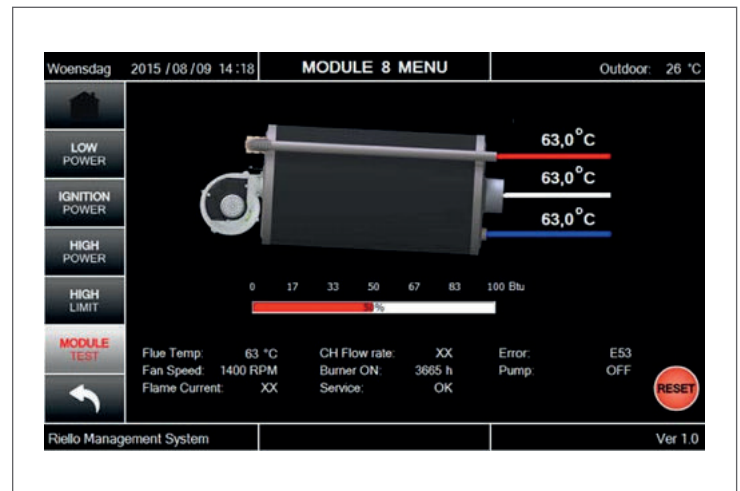

Fig. 52 Module Test Screen

Setup, adjustments and checks of combustion parameters can be done using the Low Power, Ignition Power and High Power buttons.

In addition, the High Limit button allows to carry out the high limit temperature switch functionality test.

5 SHUTDOWN

⚠ CAUTION: Risk of system damage through frost.

When there is a frost, the heating system can freeze up if it is not operational, e.g. because of a fault shutdown.

- When there is a risk of frost, protect your heating system against freezing up.
- If your heating system has been shut down for several days due to a fault shutdown and there is a risk of frost, drain the heating water at the drain & fill valve. Also leave the air vent valve at the highest point in the system open.

⚠ NOTICE: Risk of system damage through frost.

The heating system can freeze up as a result of a power failure or if the power has been switched off.

- Check the "Control unit settings" to ensure the system remains operational (especially when there is a risk of frost).

⚠ NOTICE:

- Always keep the oil supply valve shut off if the burner is shut down for an extended period of time.

5.1 Shutting down the heating system

Shut down your heating system via the control unit. Switching off the control unit also switches off the burner automatically.

- Set the On/Off switch of the control unit to Off.
- Isolate the fuel supply to the burner.

5.2 Shutting down the heating system in an emergency

Only in emergencies, switch OFF the heating system via the boiler room breaker or the heating system emergency stop switch.

- In dangerous situations, immediately close the main fuel shut-off valve and the power supply of the heating system via the boiler room main breaker or the heating system emergency stop switch.
- Isolate the fuel supply to the burner.
- Never put your life at risk. Your own safety is paramount.

6 ENVIRONMENTAL PROTECTION/DISPOSAL

Environmental protection is one of the fundamental company policies of the **RIELO**. We regard quality of performance, economy and environmental protection as equal objectives.

Environmental protection laws and regulations are strictly adhered to.

To protect the environment, we use the best possible technology and materials taking into account economic points of view.

Packaging

For the packaging, we participate in the country-specific recycling systems, which guarantee optimal recycling. All packaging materials used are environmentally-friendly and recyclable.

Old appliances

Old appliances contain resources that should be recycled.

The components are easy to separate and the plastics are marked. This allows the various components to be sorted for appropriate recycling or disposal.

APPENDIX A - WIRING DIAGRAM

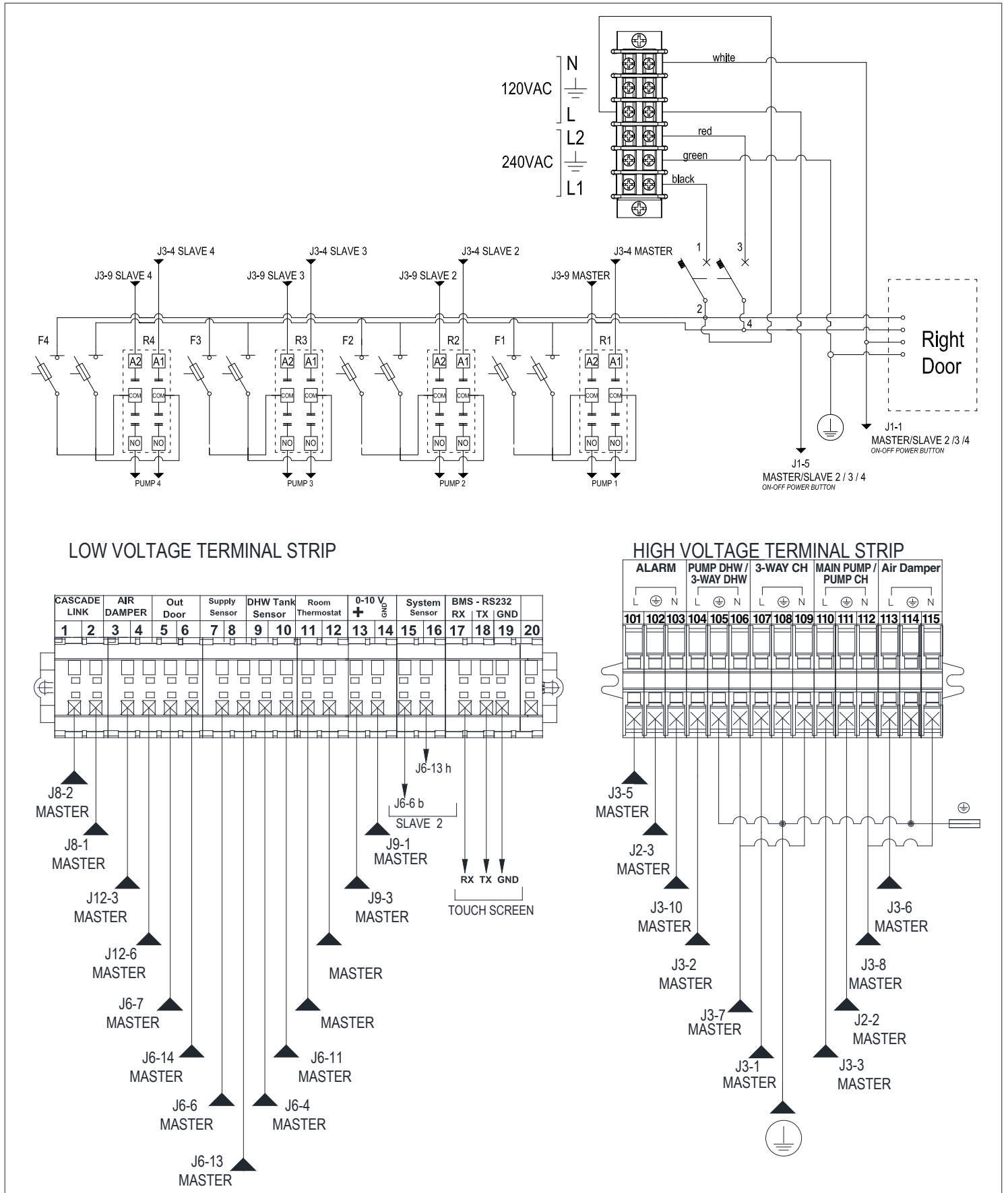

LOW VOLTAGE TERMINAL STRIP

HIGH VOLTAGE TERMINAL STRIP

WIRING DIAGRAM – MASTER – LEFT DOOR

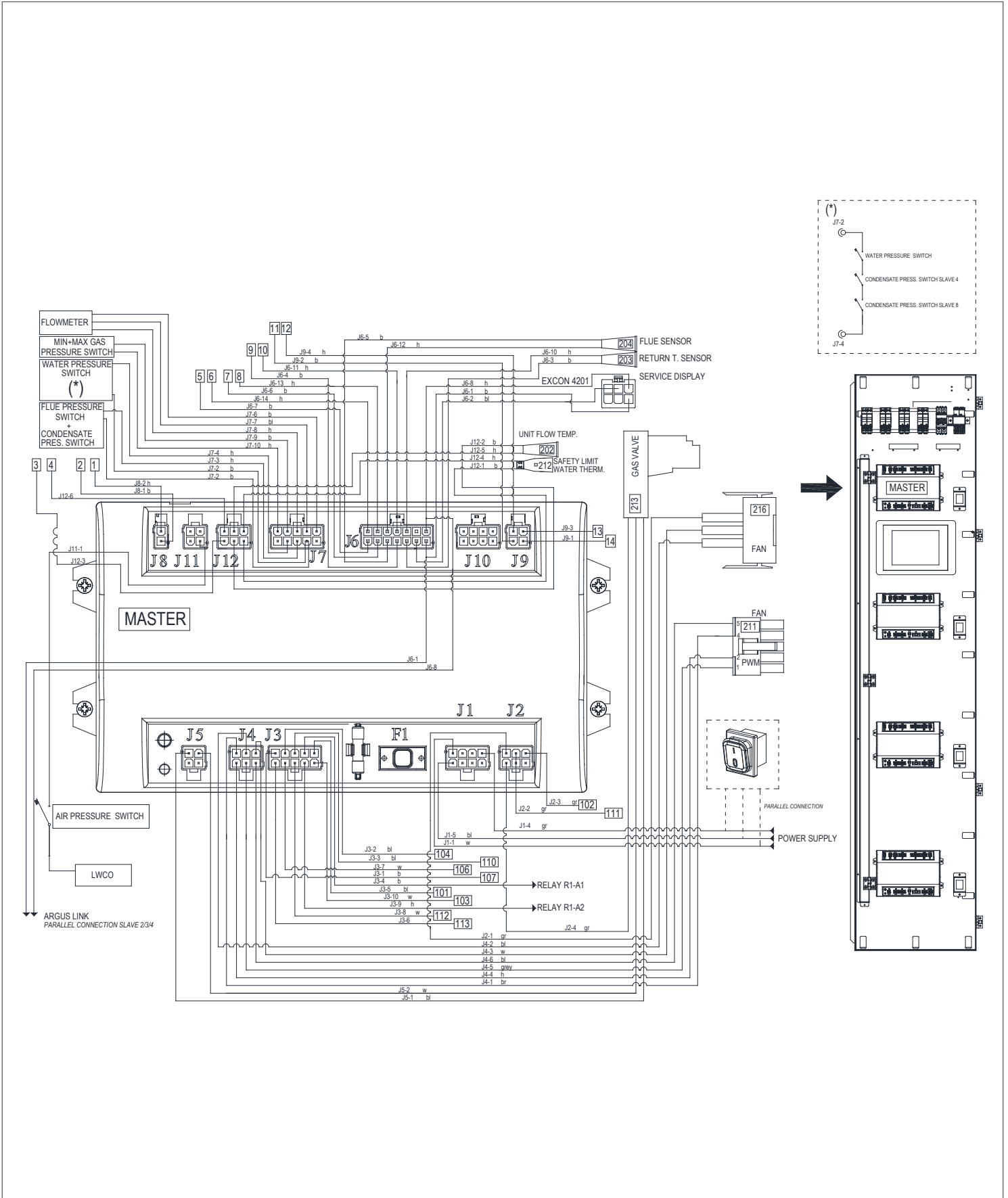

WIRING DIAGRAM – SLAVE 2 / 3 / 4 – LEFT DOOR

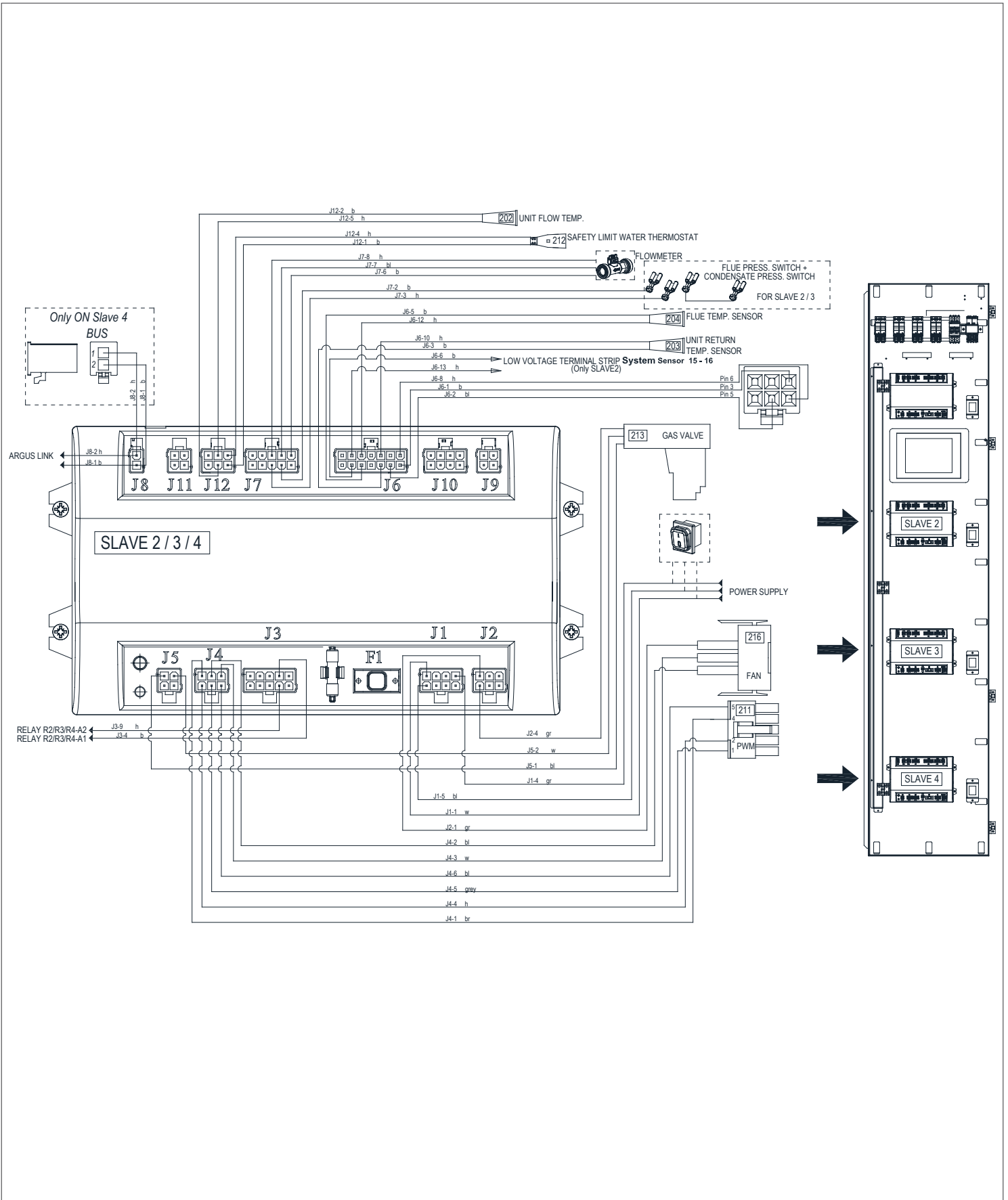

RIGHT DOOR

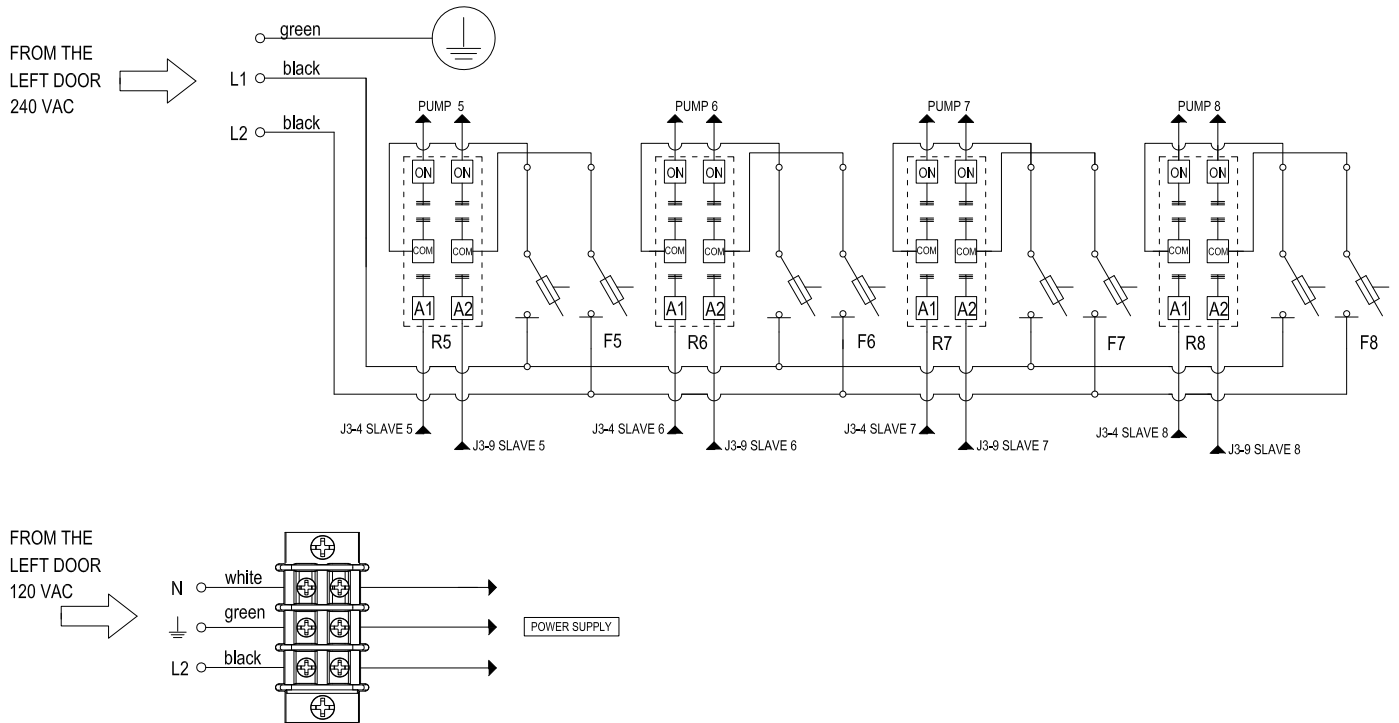

WIRING DIAGRAM – SLAVE 5 / 6 / 7 / 8 – RIGHT DOOR

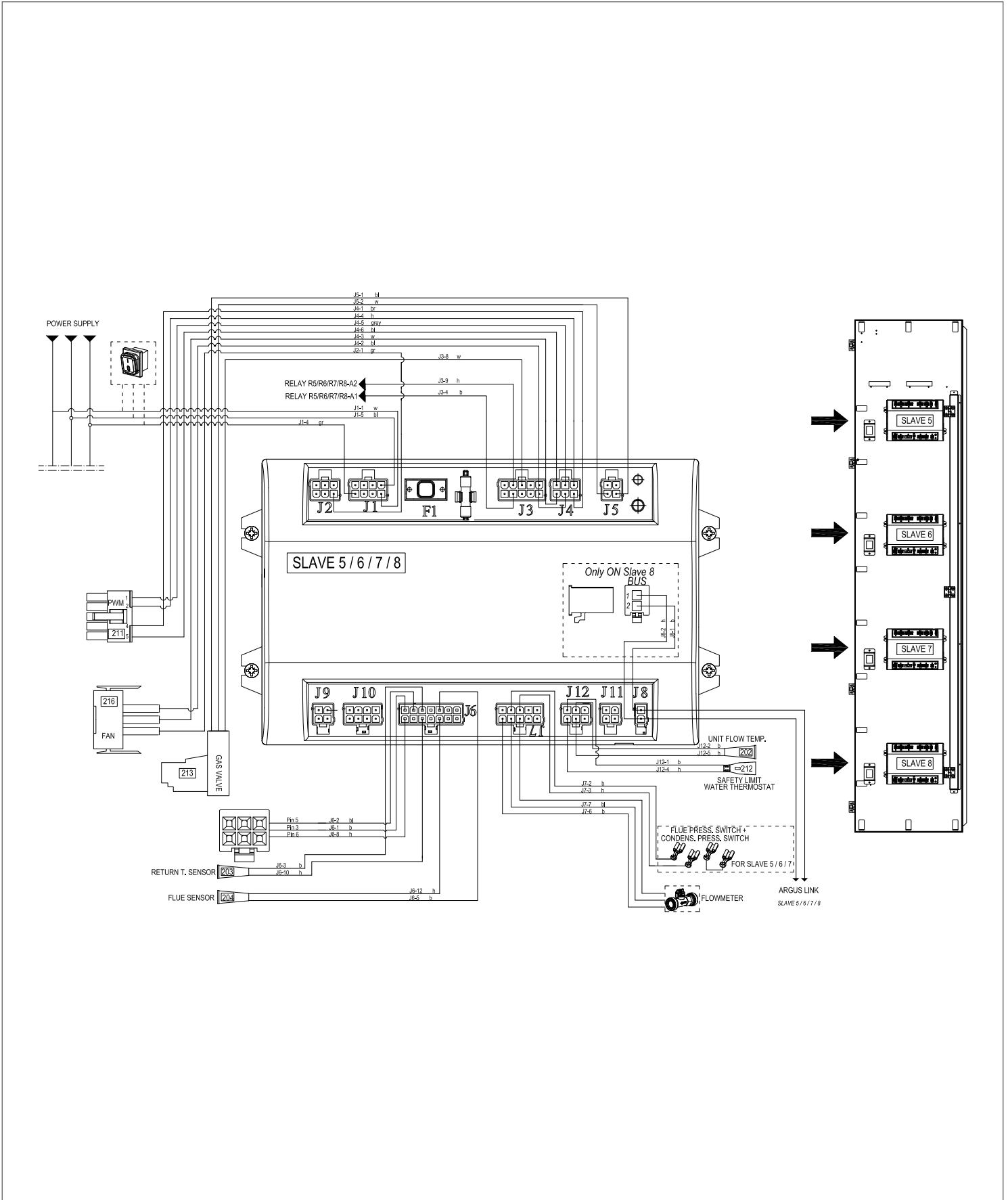

APPENDIX B – SIZE AND CONNECTIONS

ARRAY AR 3000, AR 4000

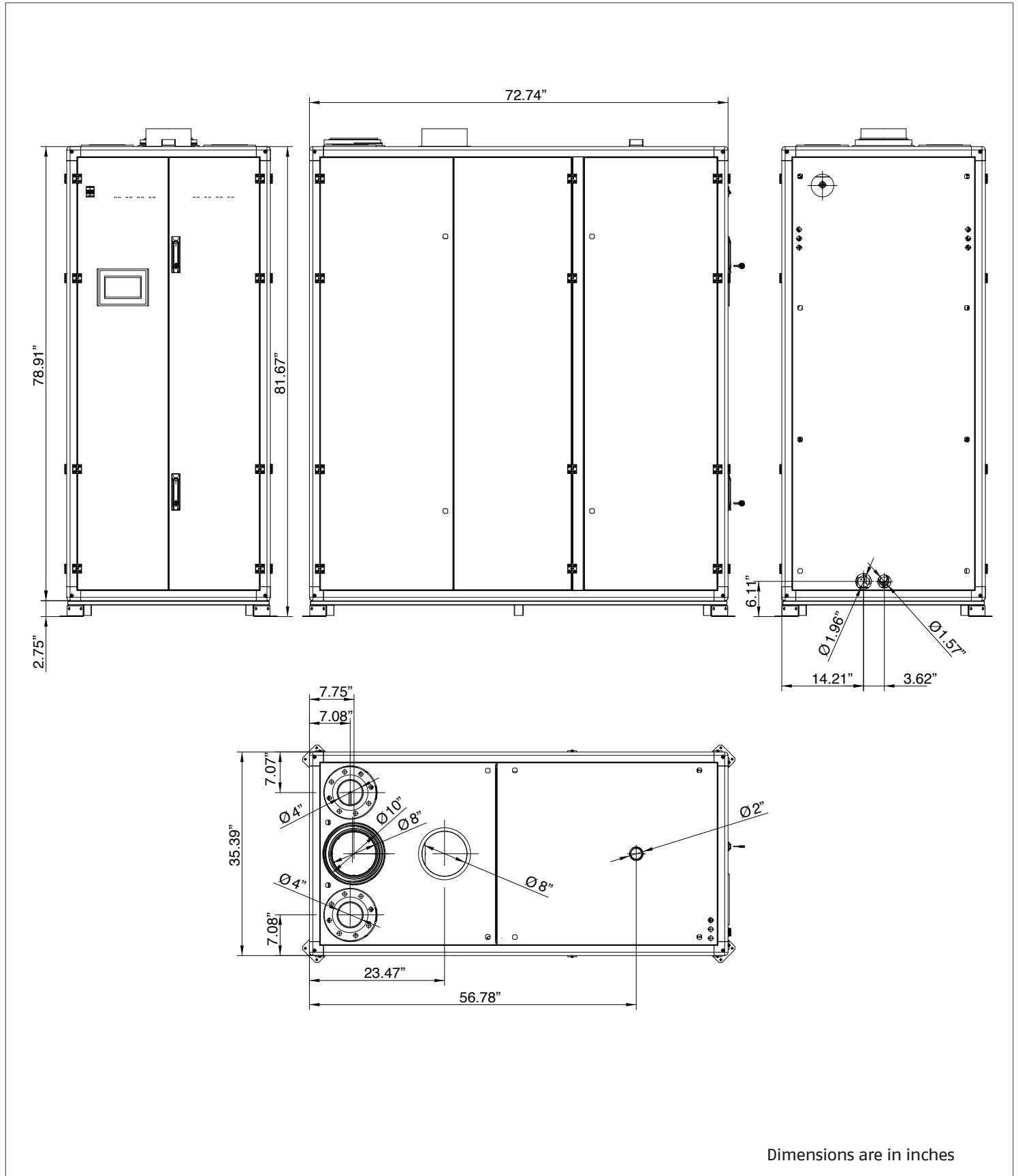

Dimensions are in inches

APPENDIX C – CONNECTION DIAGRAM

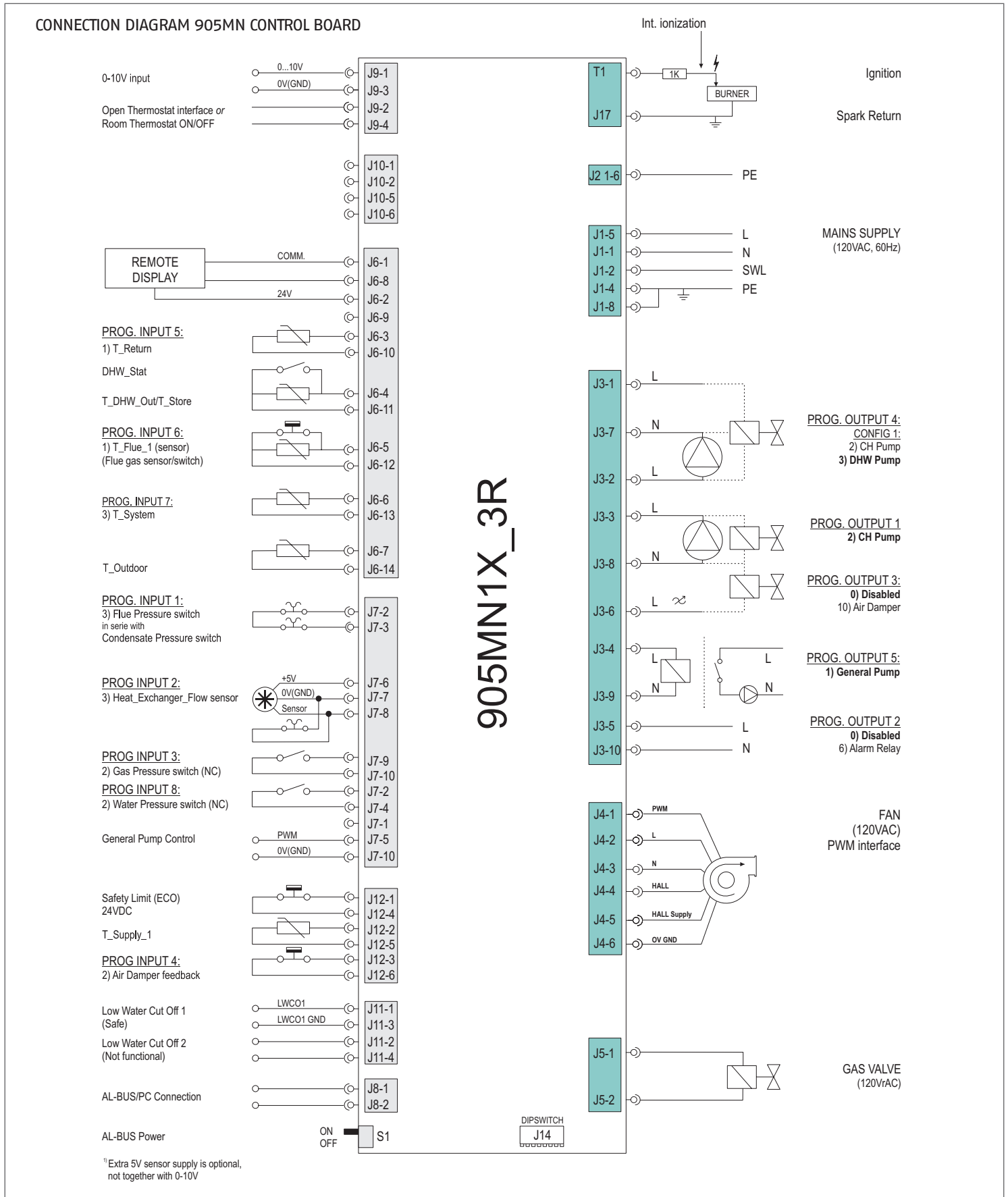

CONNECTION DIAGRAM 905PB DISPLAY

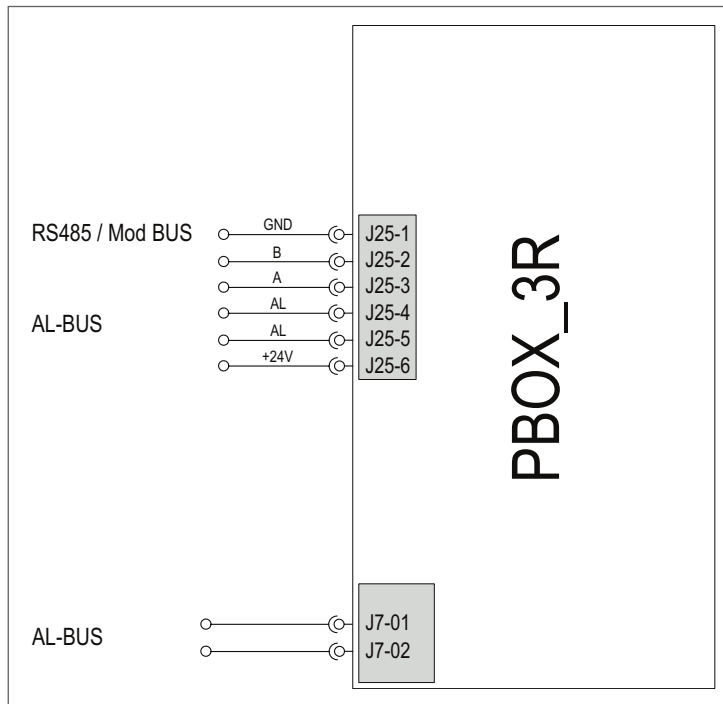

905PB05_3R	
Connector	Function
J7	PC interface
J25	Connection to MN control/Modbus

905PB05_3R Display: RJ-11 Connector:

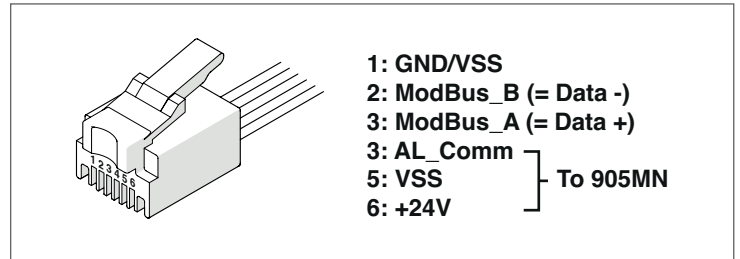

J25 Wire Colors:

- j25-1: Grey
- j25-2: Black
- j25-3: Green
- j25-4: Yellow
- j25-5: Red
- j25-6: Blue

CONNECTION DIAGRAM 905TS (Touchscreen) AND 905PB DISPLAY

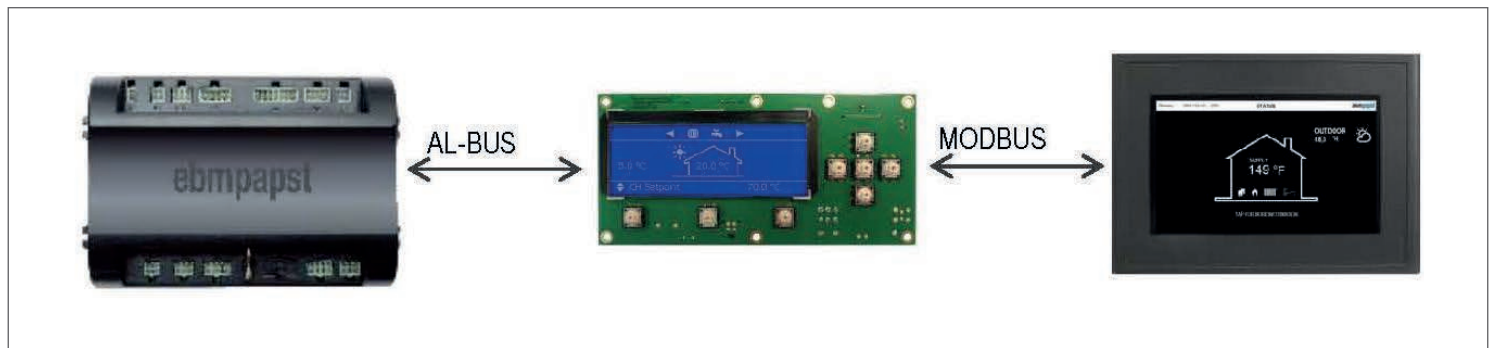

Modbus connection diagram between the 900PB and 900TS

Pins on connector COM1 of the 900TS:

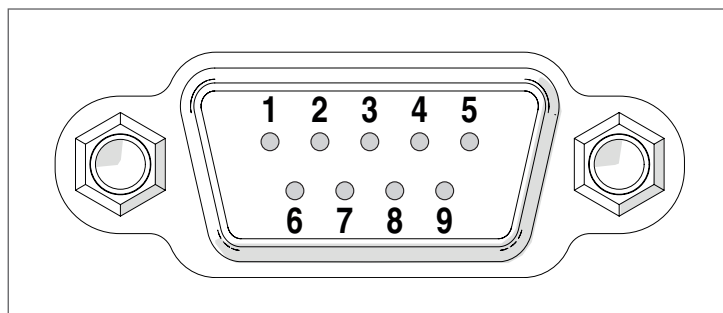

Primary connection to 900PB:

Communication	Pin	Function	Connect to
COM2 (Master)	5	GND	900 PB (J25-1)
	7	RS 485 +	900 PB (J25-3)
	8	RS 485 -	900 PB (J25-2)

Optional secondary interface:

Communication	Pin	Function	Connect to	
COM1 (Slave)	2	RS 232 RXD	External Adapter	RS 485
	3	RS 232 TXD	External Adapter	RS 485
	5	GND		

APPENDIX D – TECHNICAL DATA

	Unit	AR 3000	AR 4000
Boiler Category			ASME Sect.IV
Type of Gas		Natural Gas, Propane*	
Max input rate	BTU/hr (kW)	3,000,000 (879)	4,000,000 (1172)
Min input rate	BTU/hr (kW)	100,000 (29)	100,000 (29)
Turndown	Rate	30:1	40:1
Gas Connections (NPT)	Ø Inch	2"	2"
Max. NG Pressure	Inch W.C. (mbar)	20 (50)	20 (50)
Min. NG Pressure	Inch W.C. (mbar)	3.5 (8.7)	3.5 (8.7)
Max. LPG Pressure	Inch W.C. (mbar)	20 (50)	20 (50)
Min. LPG Pressure	Inch W.C. (mbar)	8 (19.9)	8 (19.9)
CO2 Working Range (NG)	%	8.5 – 9.5	8.5 – 9.5
Water Connections	Ø Inch	4 "	4"
Max. Allowable Working Pressure (MAWP)	PSI (bar)	80 (5.5)	80 (5.5)
Water Volume	Gallon (liter)	36 (138)	48 (184)
Water flow at max power (ΔT 36°F / 20°C)	GPM (m ³ /h)	170 (39)	227 (52)
Water flow at max power (ΔT 45°F / 25°C)	GPM (m ³ /h)	136 (31)	182 (41)
Vent/Air Intake Connections	Ø Inch (Ø mm)	8/10 (200/250)	8/10 (200/250)
Vent Materials		CPVC, PP, Stainless Steel AL29-4C	
Max operating temperature	°F (°C)	194 (90)	194 (90)
Max HE allowable temperature	°F (°C)	210 (98.9)	210 (98.9)
Ambient storage temperature	°F (°C)	5 to 158 (-15 to 70)	5 to 158 (-15 to 70)
Ambient functioning temperature	°F (°C)	32 to 120 (0 to 49)	32 to 120 (0 to 49)
Surface heat exchanger per module	SQFT (m ²)	43 (4)	43 (4)
Standard Listings & Approvals		ETL, ASME, AHRI	
Electrical Req. 230-120V/1PH/60Hz		18 FLA*	24 FLA*
Weight (dry)	lbs (kg)	2204 (1000)	2866 (1300)
Dimension WxHxD	Inch (mm)	35.4x83x72.8 (900x2108x1850)	35.4x83x72.8 (900x2108x1850)

(*) FLA (Full Load Amperage) – maximum current drawn by the boiler if all pumps reach rated horsepower

APPENDIX E - STRUCTURE

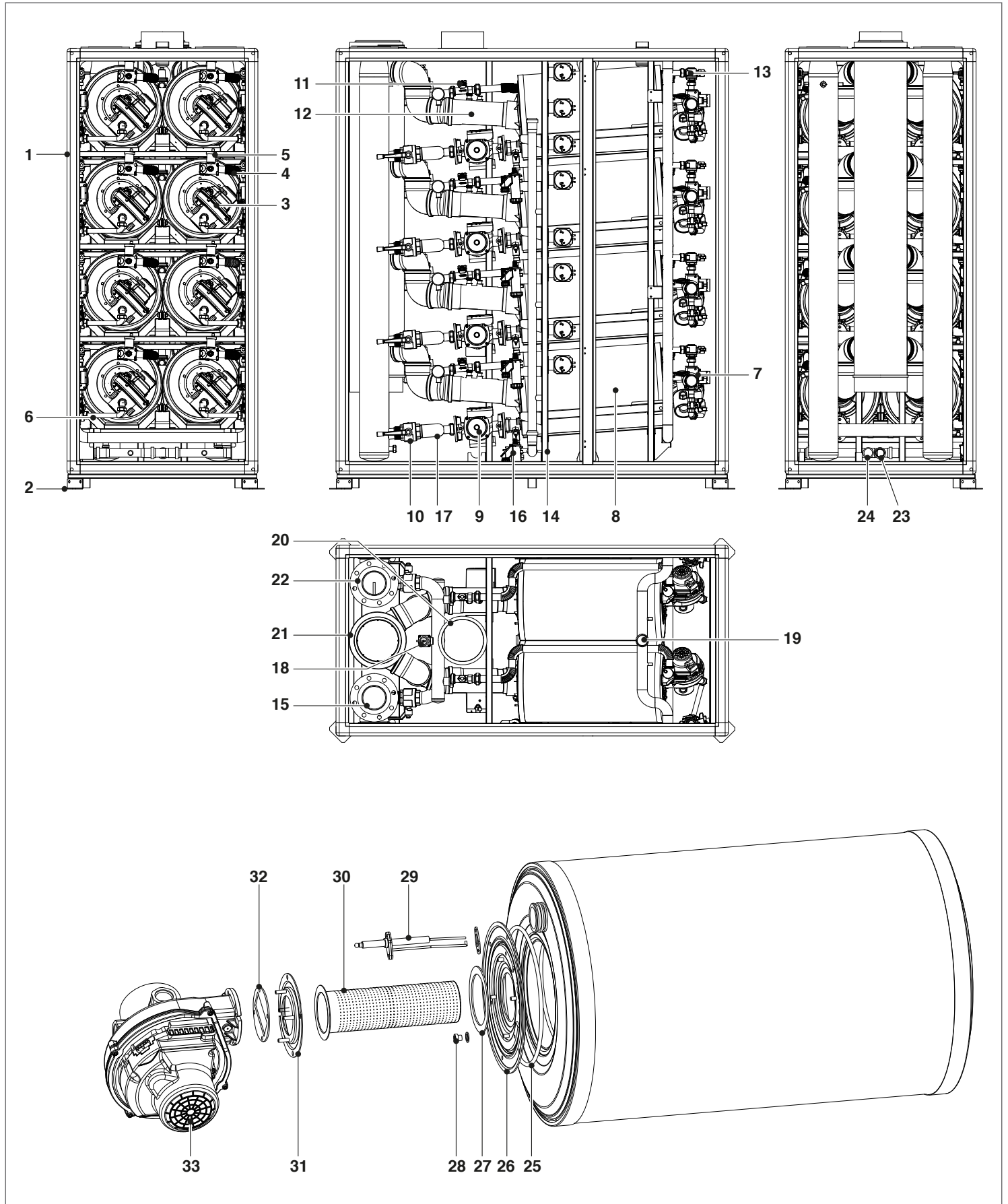

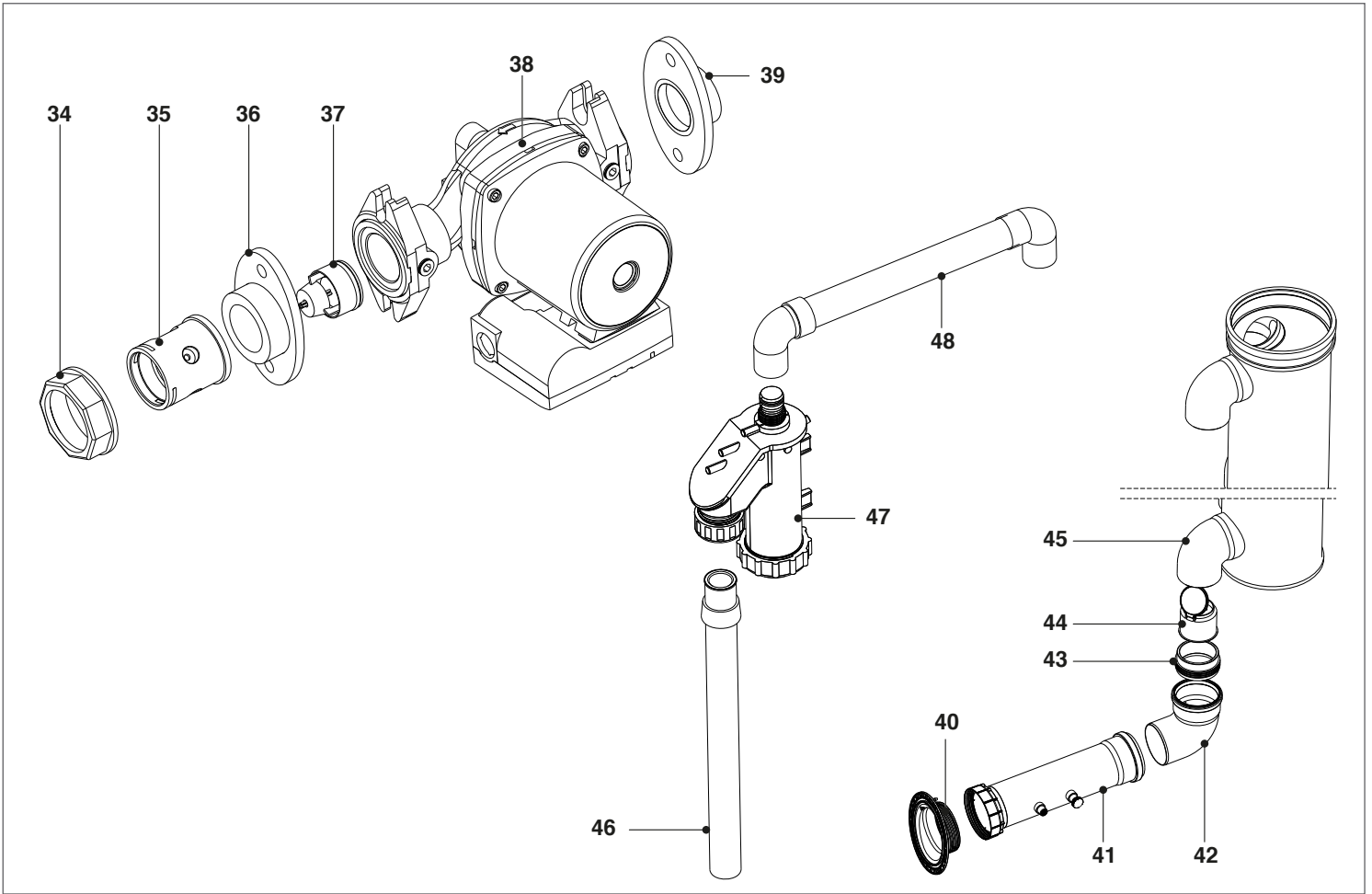

Item	Description	Q.ty
1	Outer frame	1
2	Leg	4
3	Fan	8
4	Supply pipe	8
5	Purge valve	8
6	Gas pipe	8
7	Gas valve	8
8	Heat exchanger	8
9	Pump	8
10	Water shutoff valve	8
11	Flow meter	8
12	Flue pipe	8
13	Gas shutoff valve	8
14	Inner frame	1
15	Vertical return manifold	1
16	Condensate trap	8
17	Horizontal return manifold	8
18	Relief valve	8
19	Gas connection	1
20	Air intake	1
21	Venting connection	1
22	Vertical supply manifold	1
23	Condensate drain	1
24	Relief valve drain	1

Item	Description	Q.ty
25	Burner head O-ring	1
26	Burner flange (outer)	1
27	Burner gasket	1
28	Sight glass combustion	1
29	Ingiter	1
30	Burner tube	1
31	Burner flange (inner)	1
32	Gasket burner flange	1
33	Fan	1
34	Brass connection	1
35	Brass fitting	1
36	Flange (2")	1
37	Check valve	1
38	Pump	1
39	Flange (1 1/2")	1
40	Flue plastic flange	8
41	Flue pipe	8
42	90° bend (PP)	8
43	Clapet seal (EPDM)	8
44	Clapet valve	8
45	Vertical flue manifold	1
46	Condensate pipe outlet	1
47	Condensate trap	1
48	Condensate pipe inlet	1

APPENDIX F – MAINTENANCE

A qualified and adequately trained technician must perform the inspection as specified in these instructions and in the Service Manual (provided separately) before each heating season and at regular intervals.

Servicing, inspection and adjustment must be done by a trained technician in accordance with all applicable local and national codes. Improper servicing or adjustment could damage the boiler and result in equipment damage or a dangerous condition!

MAINTENANCE / INSPECTION SCHEDULE

Time interval	Maintenance
Annually	Verify the cleanliness of the area around the boiler
Annually	Check the pressure of the hydraulic system
Annually	Check vent piping and verify if leaks are present
Annually	Check air piping and verify if leaks are present
Annually	Check relief valve
Monthly (follow local, state, federal or local authority having jurisdiction guidelines)	Verify the condensate discharge system
Every two months	Test low water cut off
Every two months	Verify the reset button of low water cut off
Every six months	Check all piping (gas and water) for leaks
End of heating season	Shut off the boiler
Annually *	Combustion test
Annually *	Verify condition of flue and air system (including Venturi and fan)
Annually *	Check ignition electrode
Annually *	Cleaning the combustion chamber (including the burner tube)
Annually *	Clean condensate discharge
Annually *	Safety block check, modulation range check, gas valve closing after burner stop
Annually *	Check control parameters
Annually *	Check for gas piping leak
Annually *	Check wiring and connection
Annually *	Verify startup
Annually *	Verify the flame
Annually *	Check relief valve
Annually *	Inspect the burner gasket

(*) Annually or every 2000 hours. Whichever occurs first.

GAS LEAKING INSPECTION

Verify all gas piping to ensure that there are no leaks.

⚠ DANGER: To verify the gas leaks use a soap solution or a gas leak detector. Do not use methods that can cause explosions!

CHECK EXHAUST AND COMBUSTION AIR PIPE SYSTEM

Clear vent systems of any obstructions, corrosion, physical damage, water stains, rust. Verify the connection between the single components.

Verify the outside terminations are clear. Clean the screens and the louvers if there is any debris.

INSPECTION OF IGNITION ELECTRODE

Verify that the electrode is clean of deposits and use a dollar bill or other material to remove deposits as required.

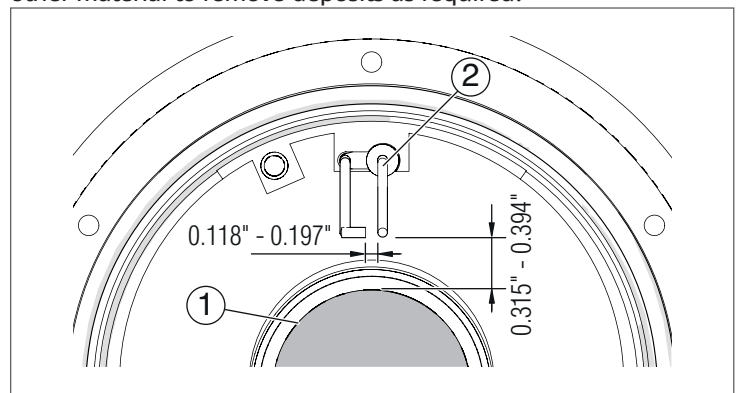

Fig. 53 Inspection of ignition electrode

No.	Description
1	Burner tube
2	Ignition electrode

CHECKING FOR WIRING AND CONNECTIONS

Check that all wiring is securely fastened and in good condition without any cracking or alteration of isolation or presence of corrosion in metallic connection.

BURNER GASKET INSPECTION

You must maintain the boiler as outlined in this manual and have the boiler started up and serviced at least annually by a qualified service technician to ensure boiler/system reliability. This includes a combustion test and the cleaning of the combustion chamber.

When disassembling the heat exchanger it is crucial to inspect the Burner Gasket (green: part number 7738004985) for damage. It is a must to replace the burner gasket when servicing and required if there is any signs of wear, deformity or discoloration of the gasket and in any case not later than every two years.

APPENDIX G – HEAD AVAILABLE FOR THE SYSTEM

HEAD AVAILABLE (NO GLYCOL)

Array	$\Delta T = 36^{\circ}\text{F}$	$\Delta T = 45^{\circ}\text{F}$
AR 3000	2ft	12ft
AR 4000	2ft	12ft

HEAD AVAILABLE (65% GLYCOL)

Array	$\Delta T = 36^{\circ}\text{F}$	$\Delta T = 45^{\circ}\text{F}$
AR 3000	0ft	9,5ft
AR 4000	0ft	9,5ft

Array Model	Boiler Quantity	Combined Max GPM	Common Pipe Size (Inch)	Max Equivalent Length of Pipe (ft)
AR 3000	1	150	4	150
	2	300	6	300
	3	450	6	150
	4	600	8	330
AR 4000	1	400	6	180
	2	800	8	180
	3	1200	10	265
	4	1600	10	160

Notes:

Max equivalent length of pipes must account for all pipes, valves, fittings and a recommended strainer at boiler inlet.
Multiple boilers to be piped in reverse return layout.

APPENDIX H – DE-RATING FOR ALTITUDE INSTALLATION

When the appliance is installed at an altitude higher than 2000 ft, the fan speed must be set to the top of the available range in any case and a de-rating of the input capacity must be considered in function of the altitude combined with the total length of the vent and combustion air pipe as reported in the following table (input BTU/hr

ARRAY AR 3000

Altitude (ft)	From 0% to 25%	From 25% to 50%	From 50% to 75%	From 75% to 100%
0-2000	3000000	3000000	3000000	3000000
3000	2753689	2705900	2658105	2610316
4000	2662349	2616142	2569935	2523728
5000	2571013	2526394	2481769	2437150
6000	2479672	2436636	2393598	2350561
7000	2388337	2346888	2305433	2263984
8000	2296996	2257129	2217262	2177401
9000	2205661	2167382	2129102	2090817
10000	2114320	2077623	2040931	2004234

ARRAY AR 4000

Altitude (ft)	From 0% to 25%	From 25% to 50%	From 50% to 75%	From 75% to 100%
0-2000	4000000	4000000	4000000	4000000
3000	3671586	3607867	3544141	3480422
4000	3549798	3488189	3426579	3364970
5000	3428018	3368526	3309026	3249533
6000	3306230	3248847	3191464	3134082
7000	3184450	3129184	3073911	3018645
8000	3062662	3009506	2956349	2903201
9000	2940881	2889842	2838803	2787757
10000	2819094	2770164	2721242	2672312

To calculate the de-rating of the input capacity follow this example:

We have an **ARRAY AR 4000** boiler installed at 5400 ft with a 10" flue system. The equivalent length of the vent pipe installed is 55 ft. The equivalent length of the air combustion pipe installed is 35 ft.

The total equivalent length of the flue system is 55+35 = 90 ft. The maximum equivalent length for this type of installation is (see IOM manual) 100 ft.

The % range is 90/100 = 90%. This value is within the 75% and 100%.

Now the correct de-rating value is given from the value of the fourth column (From 75% to 100%) that crosses the row with 6000 ft: 3134082 BTU/hr.

APPENDIX I - EFFICIENCY CURVES

ARRAY AR 3000, AR 4000

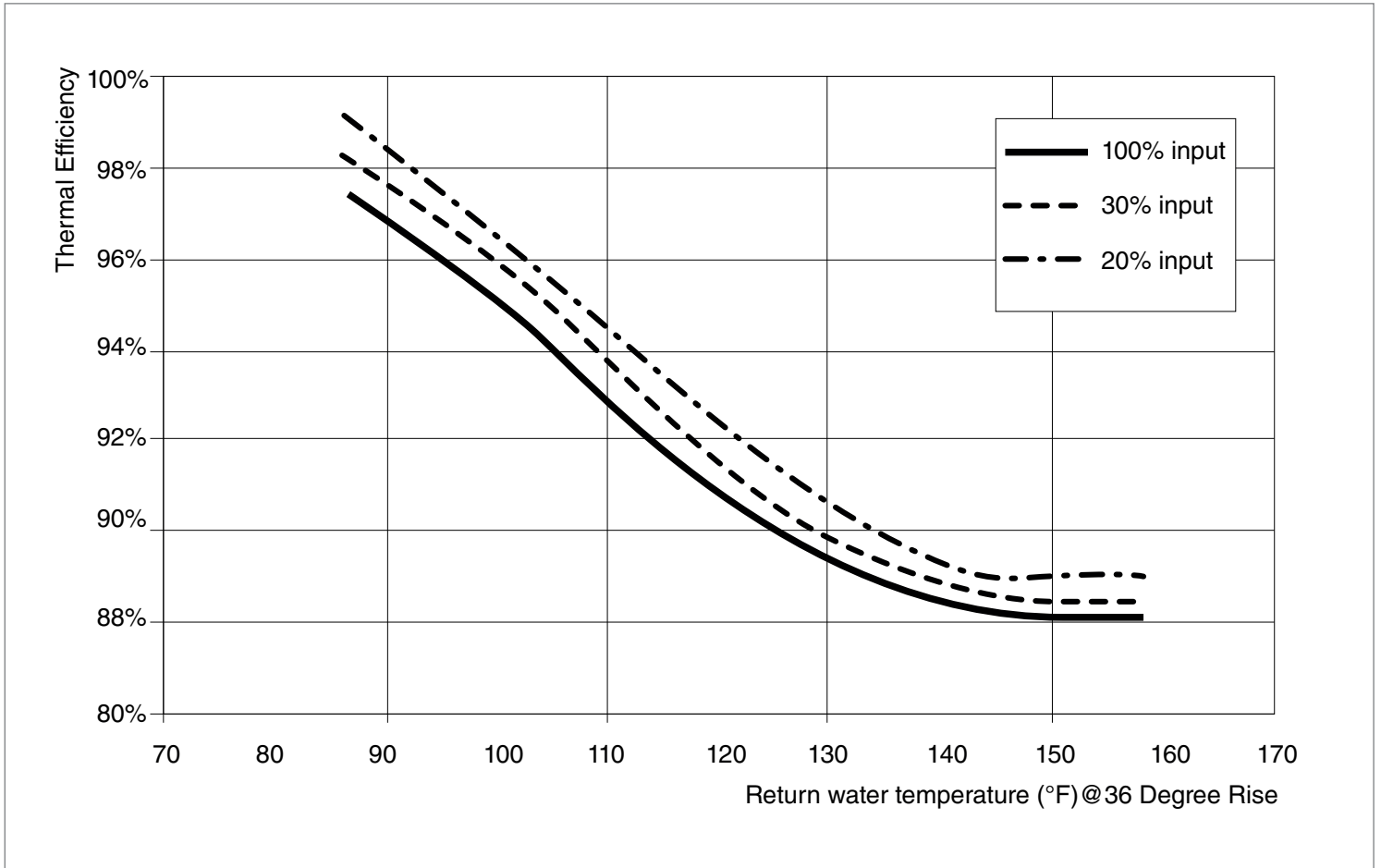

APPENDIX J – TROUBLESHOOTING TABLE

LOCKOUT CODES

Error no.	Error	Description	Checks	Solutions
0	E2PROM_READ_ERROR	Internal software error		Replace the power control board
1	IGNIT_ERROR	Three unsuccessful ignition attempts in a row	a- Check gas supply pressure; b- Check ignition spark; c- Correct amount of air; d-Check for 120VAC at the gas valve.	a- If the gas supply pressure is incorrect, it must be adjusted to the correct pressure; b- If spark is not present check for correct ignition electrode position; c- If the combustion air pressure is incorrect, inspect the vent system and eliminate any obstructions; d- If the voltage to the gas valve is not 120Vac the power control board must be replaced.
2	GV_RELAY_ERROR	Failure detected in the GV (Gas Valve) relay	a- Check the integrity of the wire connections between gas valve and control board.	a- If wires are damaged, replace them b- If wires are ok, replace the gas valve or the power control board.
3	SAFETY_RELAY_ERROR	Failure detected in the Safety relay		Replace the power control board
4	BLOCKING_TOO_LONG	Control had a blocking error for more than 20 hours	Press RESET button to display the Blocking error description	Remove the cause of the Blocking error
5	FAN_ERROR_NOT_RUNNING	Fan is not running for more than 60 seconds	a- Check for 120 Vac power connection of the fan. b- Check PWM connection of the fan.	a- If no 120 VAC voltage is present, replace the power control board; b- If no PWM signal is present, replace power control board; c- Replace the fan.
6	FAN_ERROR_TOO_SLOW	Fan runs too slow for more than 60 seconds		
7	FAN_ERROR_TOO_FAST	Fan runs too fast for more than 60 seconds		
8	RAM_ERROR	Internal software error		Replace the power control board
9	WRONG_EEPROM_SIGNATURE	Contents of E2PROM is not up to date		Replace the power control board
10	E2PROM_ERROR	Wrong safety parameters in E2PROM		Replace the power control board
11	STATE_ERROR	Internal software error		Replace the power control board
12	ROM_ERROR	Internal software error		Replace the power control board
13	APS_NOT_OPEN	Air pressure switch not working		
14	APS_NOT_CLOSED	Air pressure switch not working		

Error no.	Error	Description	Checks	Solutions
15	MAX_TEMP_ERROR	The external overheat protection is enabled or the T_Supply sensor measures a temperature of over 100°C (212°F)	a- Check the pump to verify the flow circulation; b- Check if the valves on hydraulic circuit are open; c- Check the high limit switch.	a- Change the pump or restart it; b- Open the valves on hydraulic circuit; c- Change the high limit switch.
17	STACK_ERROR	Internal software error		Replace the power control board
18	INSTRUCTION_ERROR	Internal software error		Replace the power control board
19	ION_CHECK_FAILED	Internal software error		Replace the power control board
20	FLAME_OUT_TOO_LATE	Flame still present 10 seconds after closing the gas valve		Replace the gas valve
21	FLAME_BEFORE_IGNIT	Flame is detected before ignition		Replace the gas valve
22	TOO_MANY_FLAME_LOSS	Three times flame lost during 1 demand	a- Check the integrity of the wire connections of the spark and the earth on heat exchanger b- check ionisation signal while running	a- If wires are damaged, replace them b- check for proper combustion settings - if correct replace spark/flamerod.
23	CORRUPTED_ERROR_NR	Error code RAM byte was corrupted to an unknown error code		
24	FLUE_SWITCH_NOT_CLOSING	The blocked flue sensor is not closed within 10 minutes		
25	TSUPPLY_DIFF_ERROR	The 2 supply sensors deviate too much for more than 60 seconds		
26	TFLUE_DIFF_ERROR	The 2 flue sensors deviate too much for more than 60 seconds		
27	FILLING_TOO_MUCH	Too many automated filling attempts in a short time period		
28	FILL_TIME_ERROR	Filling takes too long		
29	PSM_ERROR	Internal software error		
30	REGISTER_ERROR	Internal software error		Replace the power control board
31	T_EXCHANGE_LOCK_ERROR	Exchange temperature exceeded the maximum temperature		
32	T_EXCHANGE_DIFF_ERROR	The 2 exchange sensors deviate too much for more than 60 seconds		
33	LWCO_1_ERROR	Low Water Cut Off 1 error	Check the LWCO	a- Verify water is in the boiler. b- Verify good connection between control module and low water probe.
34	LWCO_2_ERROR	Low Water Cut Off 2 error	NA	NA
35	GAS_PRESSURE_ERROR	Flue pressure switch is open		

Error no.	Error	Description	Checks	Solutions
36	AIR_DAMPER_LOCKING	Air Damper feedback is not received when the relative output is closed for the fourth time.		
37	FLUE_PRESSURE_LOCKING	Flue pressure switch is closed for the fourth time.		

BLOCKING ERRORS

Error no.	Error	Description	Checks	Solutions
100	WD_ERROR_RAM	Internal software error		Replace the power control board
101	WD_ERROR_ROM	Internal software error		Replace the power control board
102	WD_ERROR_STACK	Internal software error		Replace the power control board
103	WD_ERROR_REGISTER	Internal software error		Replace the power control board
104	WD_ERROR_XRL	Internal software error		Replace the power control board
105	HIGH_TEMP_ERROR	Supply temperature exceeds 110°C (230°F) with gas valve closed	a- Check the pump to verify the flow circulation; b- Check if the valves on hydraulic circuit are open; c- Check the supply temperature sensor.	a- Change the pump or restart it; b- Open the valves on hydraulic circuit; c- Verify that the temperature sensor has the correct resistance values. If values are incorrect sensor must be replaced.
106	REFHI_TOO_HIGH	Internal software error		Replace the power control board
107	REFHI_TOO_LOW	Internal software error		Replace the power control board
108	REFLO_TOO_HIGH	Internal software error		Replace the power control board
109	REFLO_TOO_LOW	Internal software error		Replace the power control board
110	REFHI2_TOO_HIGH	Internal software error		Replace the power control board
111	REFHI2_TOO_LOW	Internal software error		Replace the power control board
112	REFLO2_TOO_HIGH	Internal software error		Replace the power control board
113	REFLO2_TOO_LOW	Internal software error		Replace the power control board
114	FALSE_FLAME	Flame is detected in a state in which no flame is allowed to be seen		Replace the power control board
115	LOW_WATER_PRESSURE_ERROR	Low water pressure error		
116	LOW_WATER_PRESSURE_SENSOR	Low water pressure		
117	BLOCKED_DRAIN	Blocked drain switch is active		
118	WD_COMM_ERROR	Watchdog communication error		Replace the power control board

Error no.	Error	Description	Checks	Solutions
119	RETURN_OPEN	Return sensor open	a- Check the integrity of the wire connections; b- Check the return temperature sensor.	a- If the wiring is damaged, replace it; b- Verify that the temperature sensor has the correct resistance values. If values are incorrect sensor must be replaced.
120	SUPPLY_OPEN	Supply sensor open	a- Check the integrity of the wire connections; b- Check the supply temperature sensor.	a- If the wiring is damaged, replace it; b- Verify that the temperature sensor has the correct resistance values. If values are incorrect sensor must be replaced.
121	SUPPLY2_OPEN	Supply2 sensor open		
122	DHW_OPEN	DHW sensor open	a- Check the integrity of the wire connections; b- Check the DHW temperature sensor.	a- If the wiring is damaged, replace it; b- Verify that the temperature sensor has the correct resistance values. If values are incorrect sensor must be replaced.
123	FLUE_OPEN	Flue sensor open		
124	FLUE2_OPEN	Flue2 sensor open		
125	OUTDOOR_OPEN	Outdoor sensor open	a- Check the integrity of the wire connections; b- Check the Outdoor temperature sensor.	a- If the wiring is damaged, replace it; b- Verify that the temperature sensor has the correct resistance values. If values are incorrect sensor must be replaced.
126	RETURN_SHORTED	Return sensor shorted	a- Check the integrity of the wire connections; b- Check the return temperature sensor.	a- If the wiring is damaged, replace it; b- Verify that the temperature sensor has the correct resistance values. If values are incorrect sensor must be replaced.
127	SUPPLY_SHORTED	Supply sensor shorted	a- Check the integrity of the wire connections; b- Check the supply temperature sensor.	a- If the wiring is damaged, replace it; b- Verify that the temperature sensor has the correct resistance values. If values are incorrect sensor must be replaced.
128	SUPPLY2_SHORTED	Supply2 sensor shorted		
129	DHW_SHORTED	DHW sensor shorted	a- Check the integrity of the wire connections; b- Check the DHW temperature sensor.	a- If the wiring is damaged, replace it; b- Verify that the temperature sensor has the correct resistance values. If values are incorrect sensor must be replaced.
130	FLUE_SHORTED	Flue sensor shorted		
131	FLUE2_SHORTED	Flue2 sensor shorted		
132	OUTDOOR_SHORTED	Outdoor sensor shorted	a- Check the integrity of the wire connections; b- Check the Outdoor temperature sensor.	a- If the wiring is damaged, replace it; b- Verify that the temperature sensor has the correct resistance values. If values are incorrect sensor must be replaced.

Error no.	Error	Description	Checks	Solutions
133	RESET_BUTTON_ERROR	Too many resets in a short time period		
135	T_EXCHANGE_BLOCK_ERROR	Exchange temperature exceeded 90°C		
136	T_CHIMNEY_OPEN	Chimney sensor open		
137	T_EXCHANGE1_OPEN	Exchange 1 sensor open		
138	T_EXCHANGE2_OPEN	Exchange 2 sensor open		
139	T_SELECTION1_OPEN	Selection 1 sensor open		
140	T_SELECTION2_OPEN	Selection 2 sensor open		
141	T_SELECTION3_OPEN	Selection 3 sensor open		
142	T_OPTIONAL1_OPEN	Optional 1 sensor open		
143	T_OPTIONAL2_OPEN	Optional 2 sensor open		
144	T_AMBIENT_OPEN	Ambient sensor open		
145	T_CHIMNEY_CLOSED	Chimney sensor shorted		
146	T_EXCHANGE1_CLOSED	Exchange 1 sensor shorted		
147	T_EXCHANGE2_CLOSED	Exchange 2 sensor shorted		
148	T_SELECTION1_CLOSED	Selection 1 sensor shorted		
149	T_SELECTION2_CLOSED	Selection 2 sensor shorted		
150	T_SELECTION3_CLOSED	Selection 3 sensor shorted		
151	T_OPTIONAL1_CLOSED	Optional 1 sensor shorted		
152	T_OPTIONAL2_CLOSED	Optional 2 sensor shorted		
153	T_AMBIENT_CLOSED	Ambient sensor shorted		
154	WD_CONFIG_ERROR	Watchdog fan configuration setting error		
155	FLUE_PRESSURE_ERROR	Flue pressure switch is closed	a- Check for any obstruction in the exhaust system; b- Check the condensate discharge.	a- Remove any obstructions from the exhaust system; b- Remove any obstruction from condensate discharge and verify if the condensate can flow freely.
156	AIR_DAMPER_ERROR	Air Damper feedback is not received when the relevant output is closed		
157	T_SECONDARY_SUPPLY_OPEN	Secondary circuit supply sensor open		
158	T_SECONDARY_RETURN_OPEN	Secondary circuit return sensor open		
159	T_SECONDARY_SUPPLY_CLOSED	Secondary circuit supply sensor shorted		
160	T_SECONDARY_RETURN_CLOSED	Secondary circuit return sensor shorted		
161	FILL_WARNING	Pressure is too low, demand has stopped but no error needed to be stored at this time		
162	FLUE_BLOCKED	Flue is blocked, demand needs to be stopped with fan at ignition speed but no error needed to be stored at this time		

Error no.	Error	Description	Checks	Solutions
163	LOWEXFLOW_PROTECTION	Flow is too low, demand needs to be stopped with fan at ignition speed but no error needed to be stored at this time		

WARNINGS

Error no.	Error	Description	Checks	Solutions
200	CC_LOSS_COMMUNICATION	Cascade System: Leading burner lost communication with one of the depending burners		
201	CC_LOSS_BOILER_COMM	Cascade System: Leading boiler lost communication with one of the depending boilers		
202	OUTDOOR_WRONG	Outdoor sensor is open or shorted		
203	T_SYSTEM_WRONG	T_System sensor is open or shorted		
204	T_CASCADE_WRONG	T_Cascade sensor is open or shorted		

APPENDIX K – BOILER INSTALLATION (EXAMPLE DRAWINGS)

ARRAY AR 3000 / AR 4000 Single Unit Installation

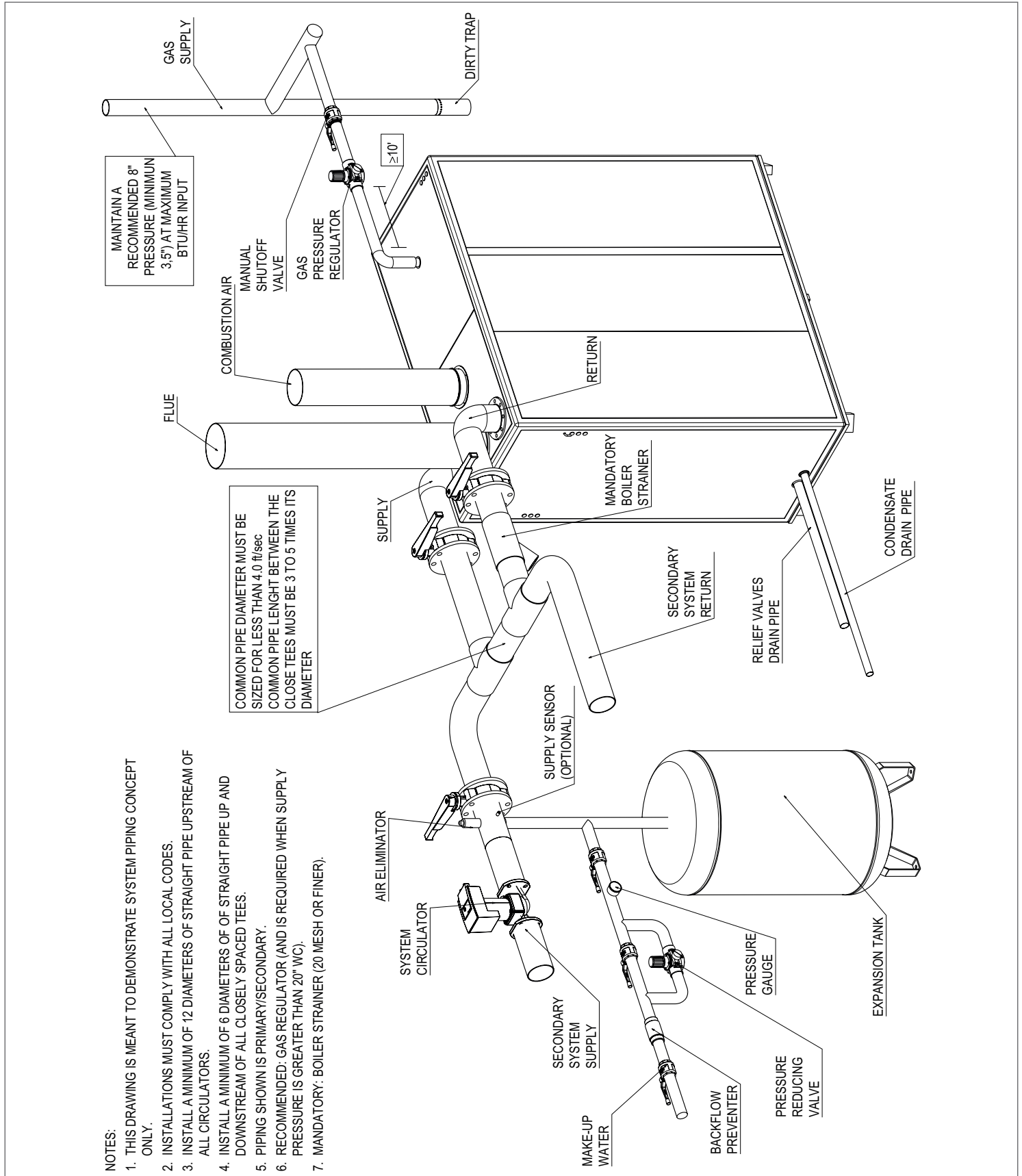

ARRAY AR 3000 / AR 4000 Multiple Units Installation

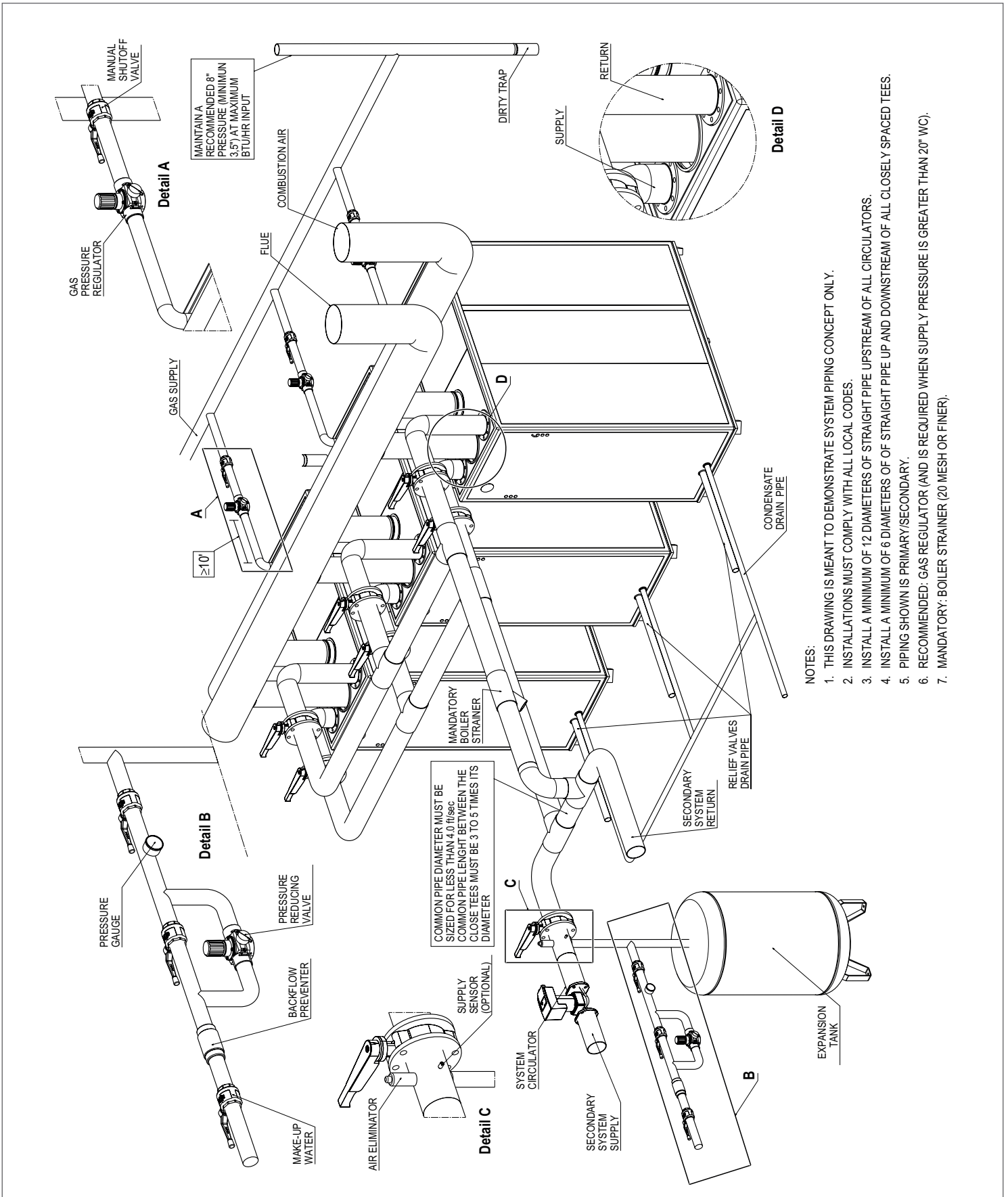

- NOTES:
1. THIS DRAWING IS MEANT TO DEMONSTRATE SYSTEM PIPING CONCEPT ONLY.
 2. INSTALLATIONS MUST COMPLY WITH ALL LOCAL CODES.
 3. INSTALL A MINIMUM OF 12 DIAMETERS OF STRAIGHT PIPE UPSTREAM OF ALL CIRCULATORS.
 4. INSTALL A MINIMUM OF 6 DIAMETERS OF STRAIGHT PIPE UP AND DOWNSTREAM OF ALL CLOSELY SPACED TEES.
 5. PIPING SHOWN IS PRIMARY/SECONDARY.
 6. RECOMMENDED: GAS REGULATOR (AND IS REQUIRED WHEN SUPPLY PRESSURE IS GREATER THAN 20" WC).
 7. MANDATORY: BOILER STRAINER (20 MESH OR FINER).

APPENDIX L - LADDER DIAGRAM

MAIN POWER

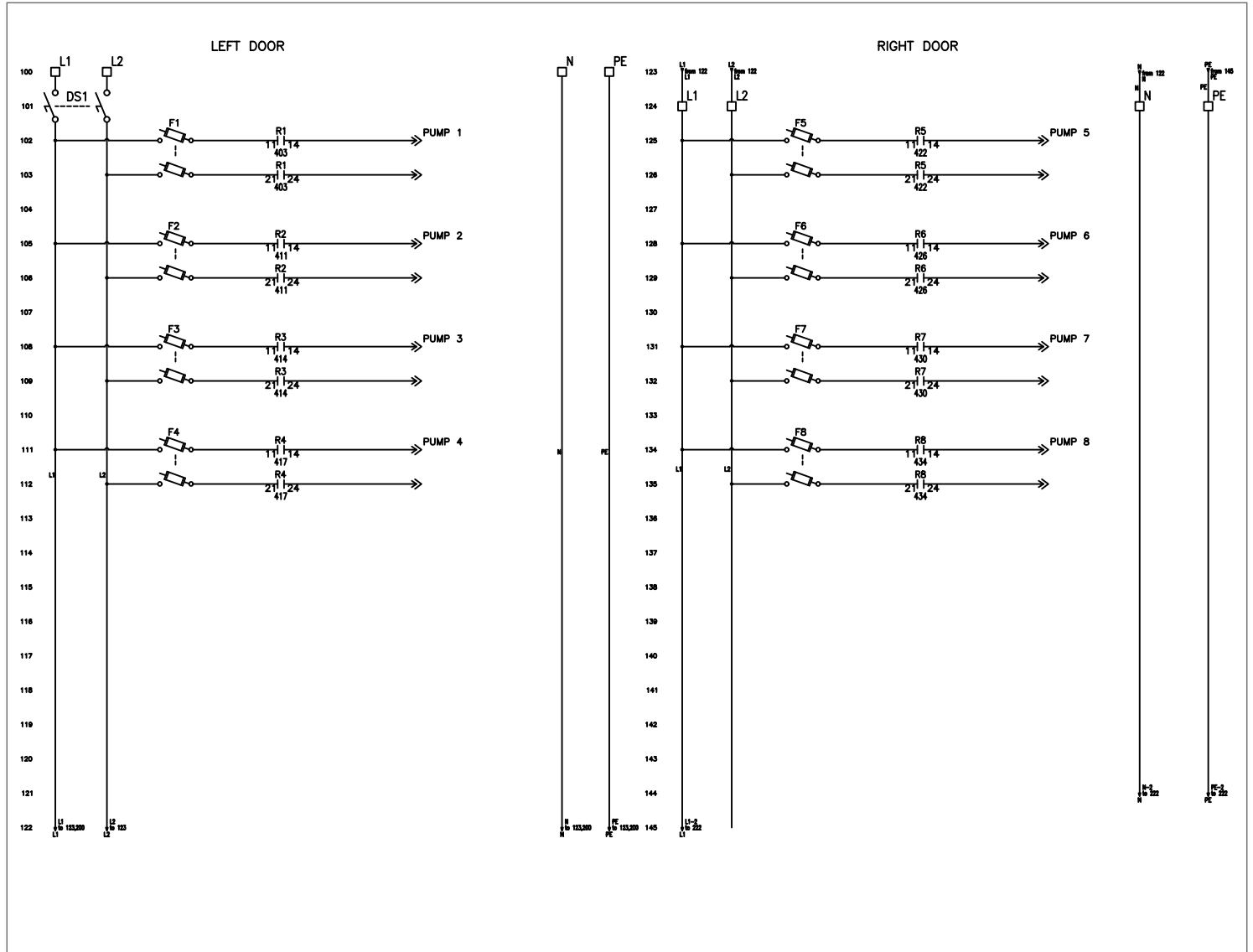

MASTER SLAVE POWER

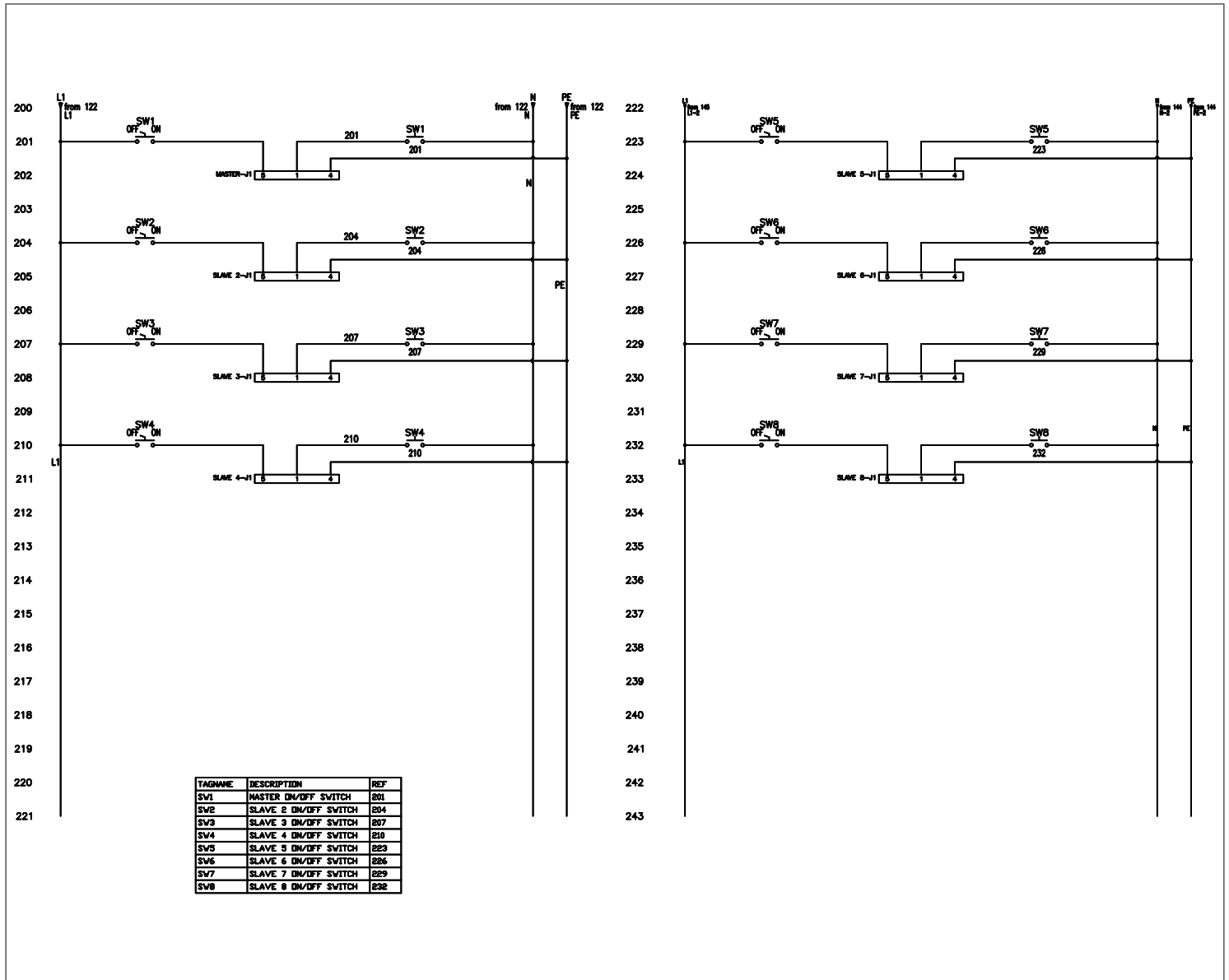

J2 CONNECTIONS

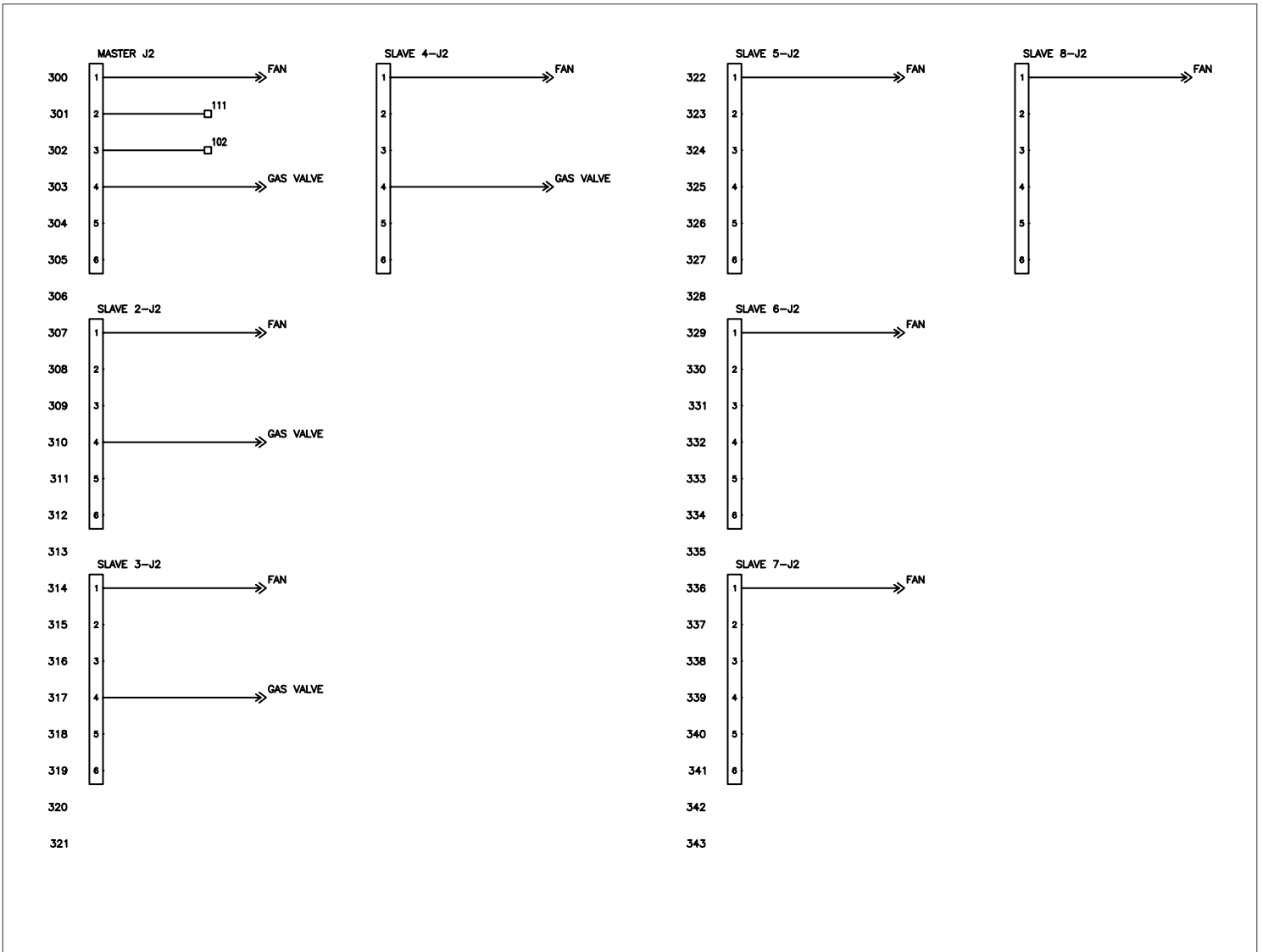

J3 CONNECTIONS

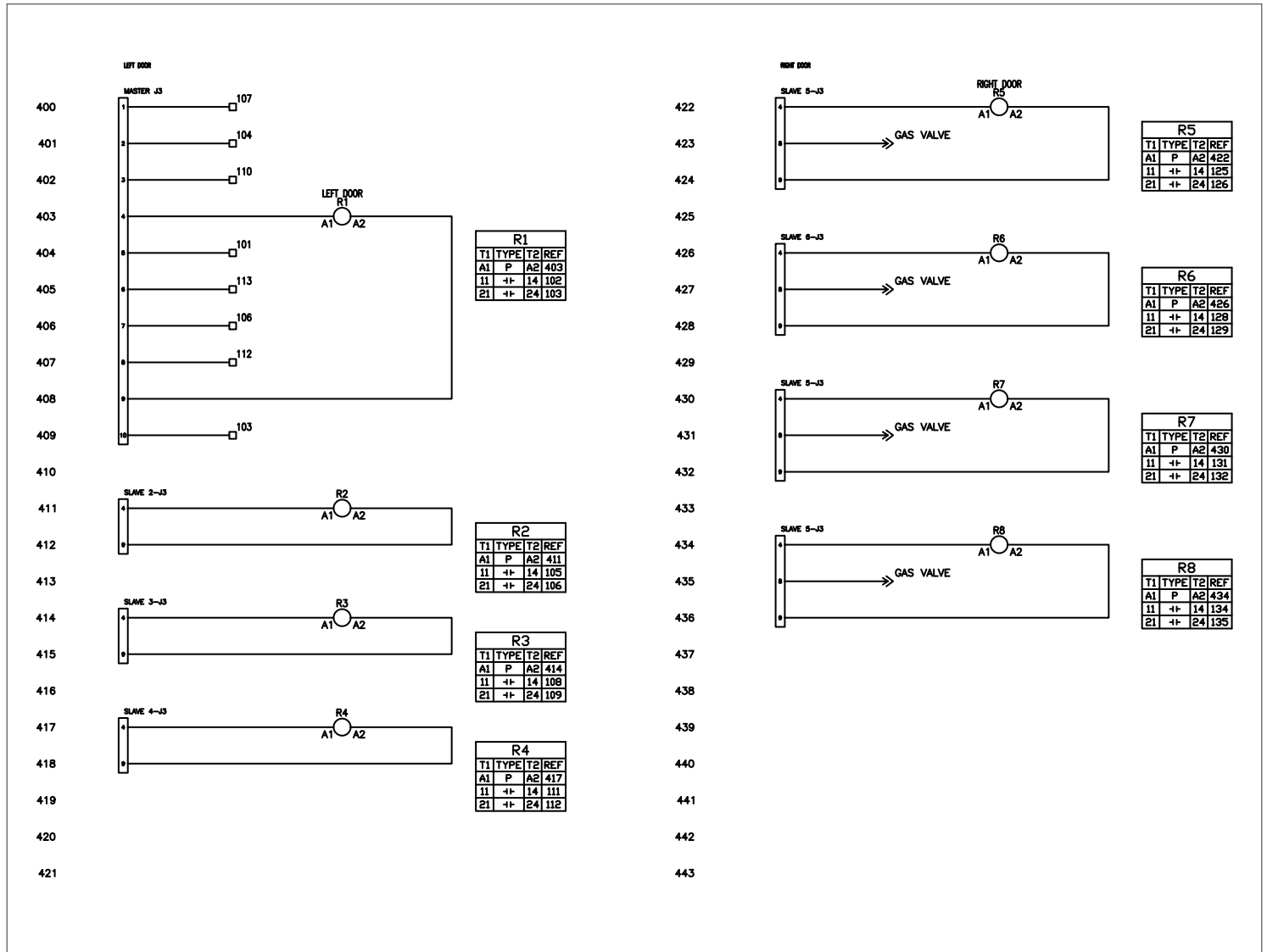

J4 CONNECTIONS

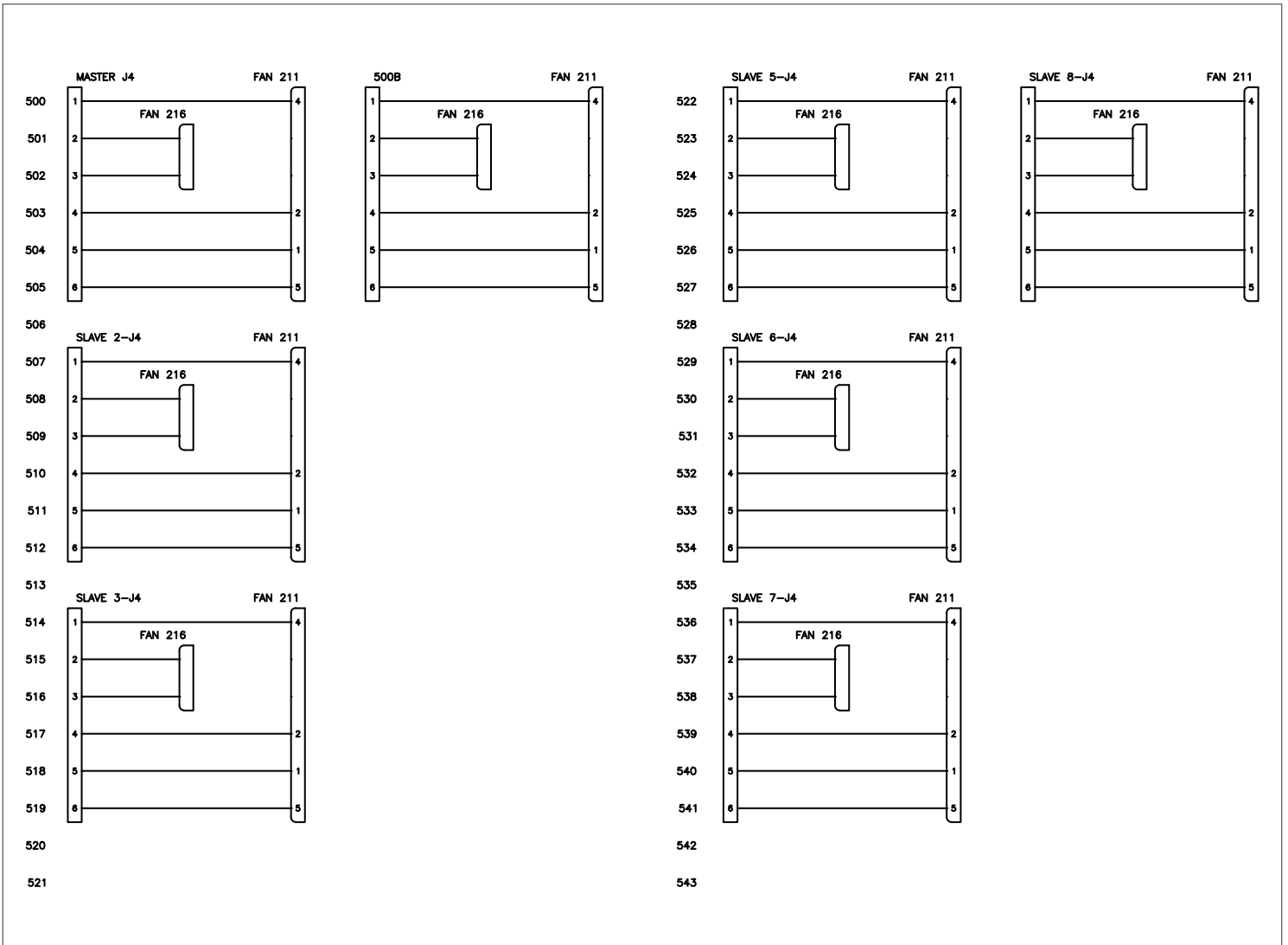

J5 CONNECTIONS

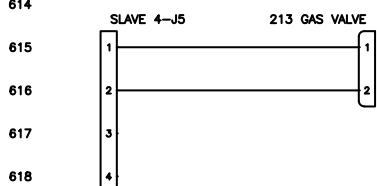
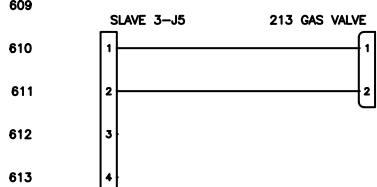
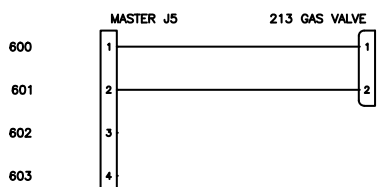

619

620

621



641

642

643

J6 CONNECTIONS

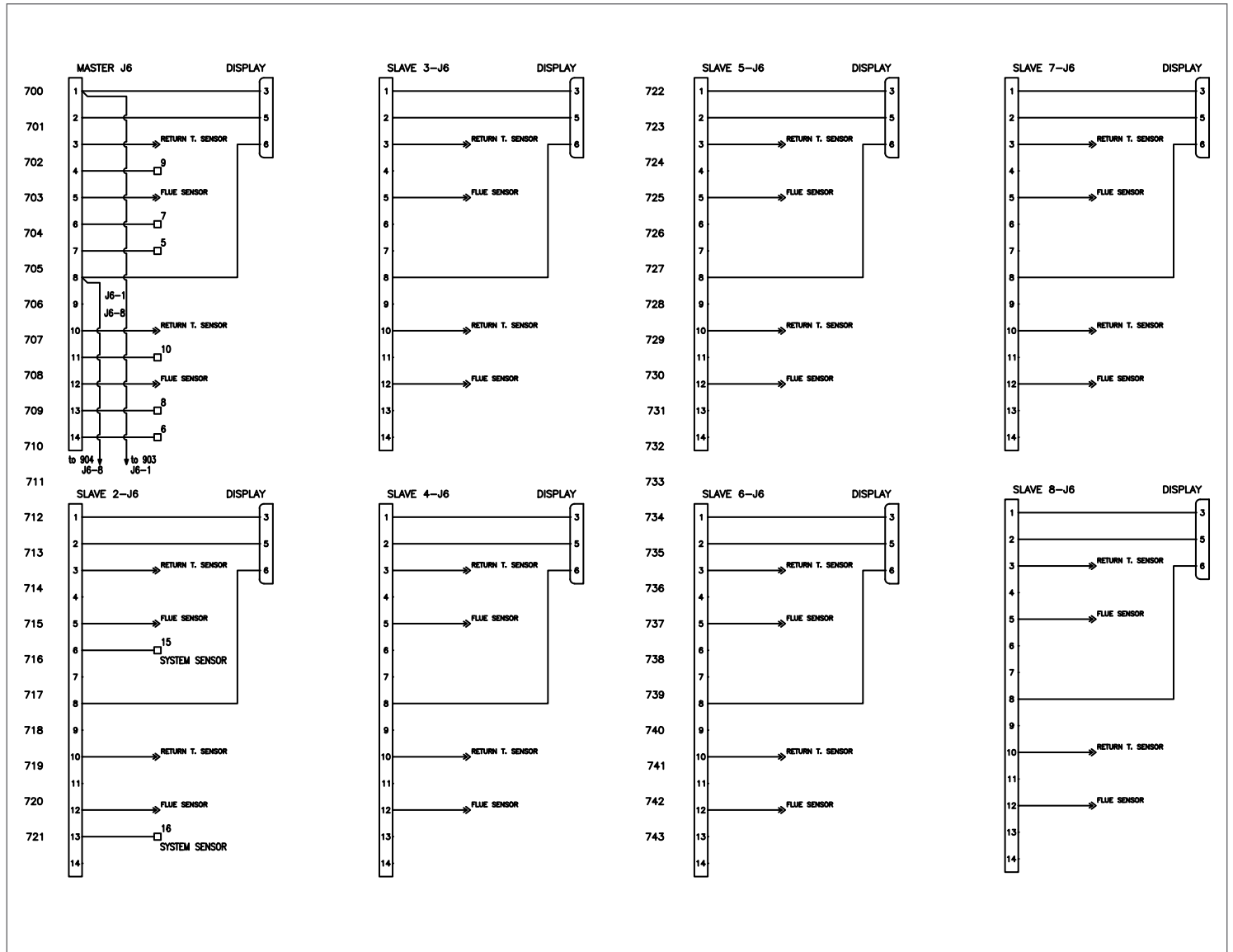

J7 CONNECTIONS

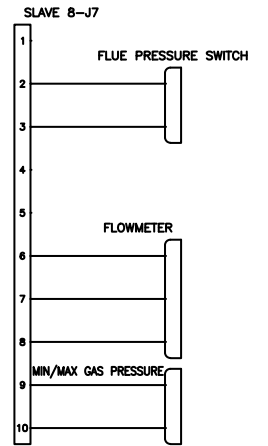
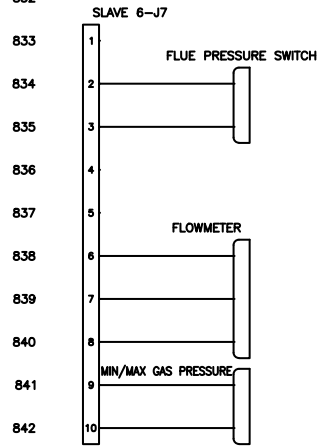
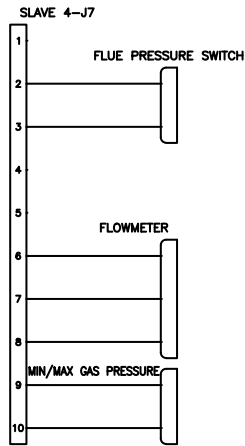
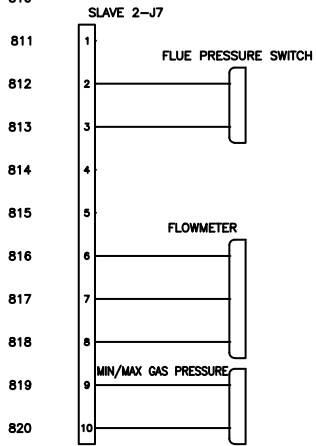
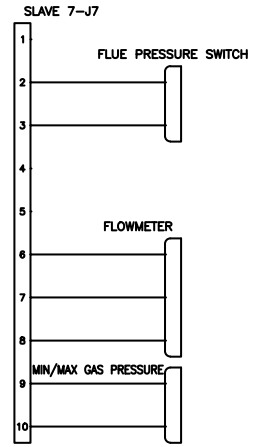
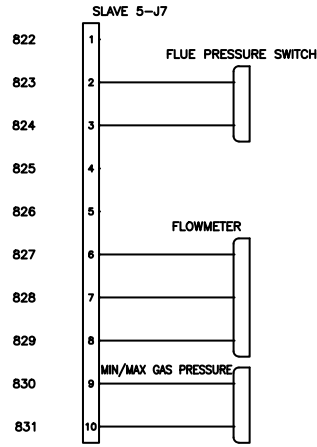
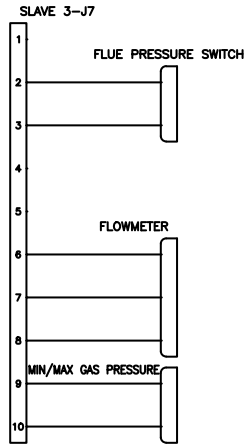
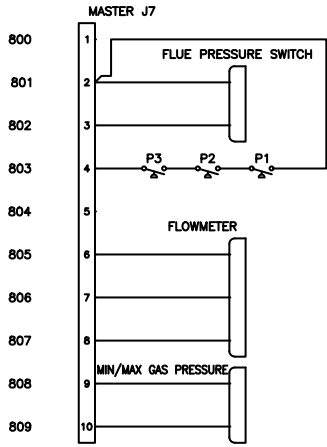

TABNAME	DESCRIPTION	REF
P1	WATER PRESSURE SWITCH	883
P2	CONDENSATE PRESSURE SWITCH SLAVE 4	883
P3	CONDENSATE PRESSURE SWITCH SLAVE 8	883

J8-J9 CONNECTIONS

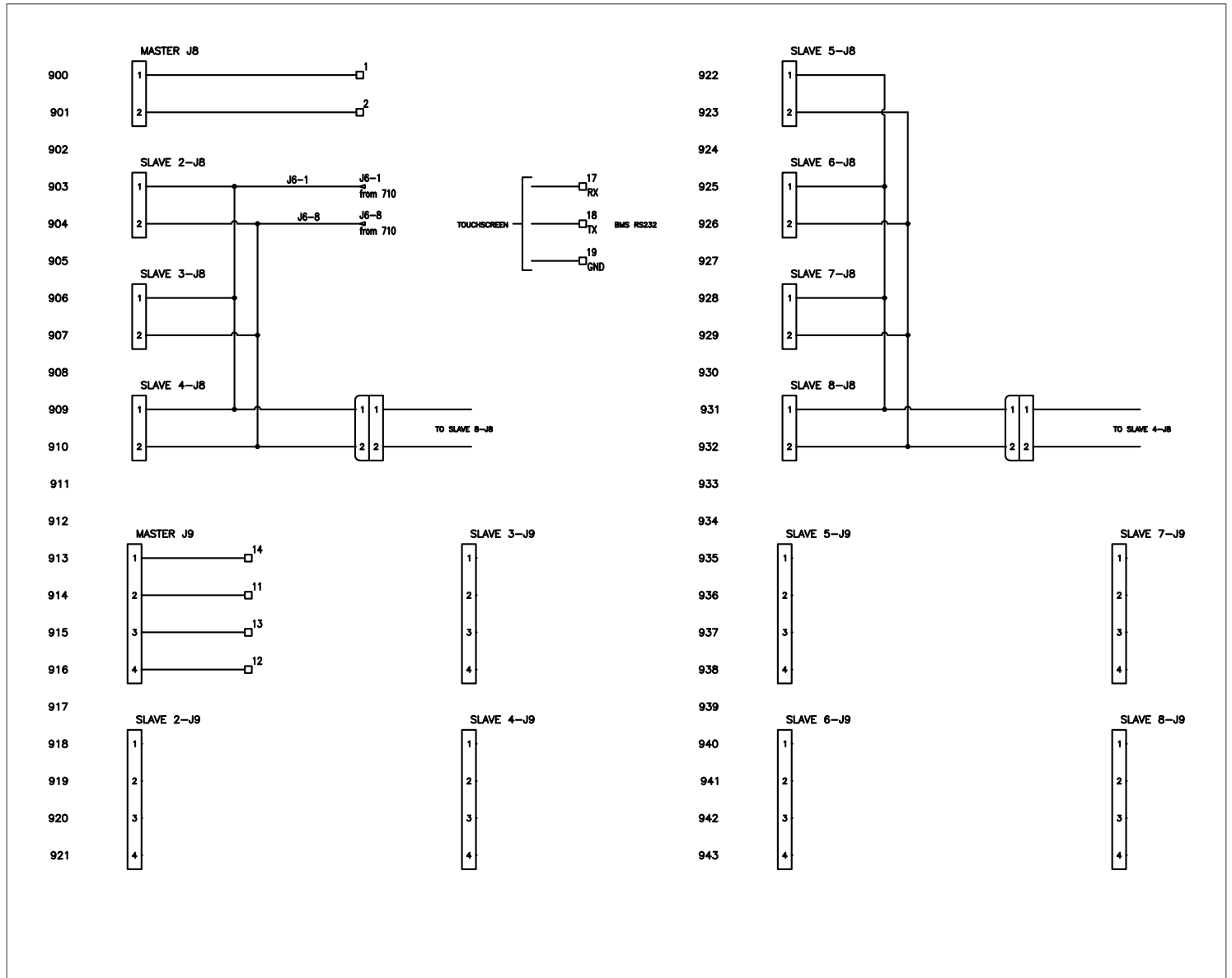

J10-J11 CONNECTIONS

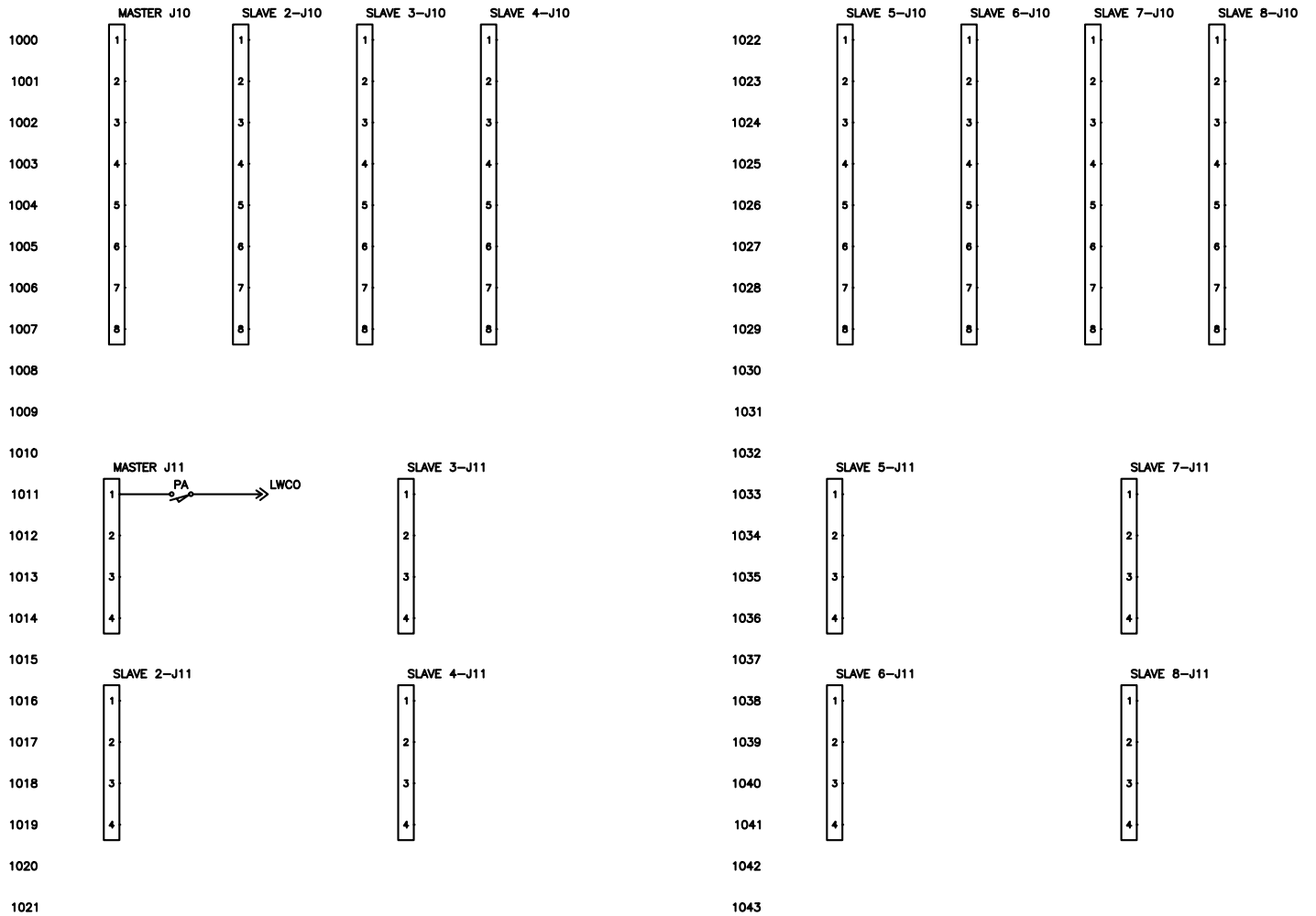

TAGNAME	DESCRIPTION	REF
PA	AIR PRESSURE	1011

J12 CONNECTIONSI

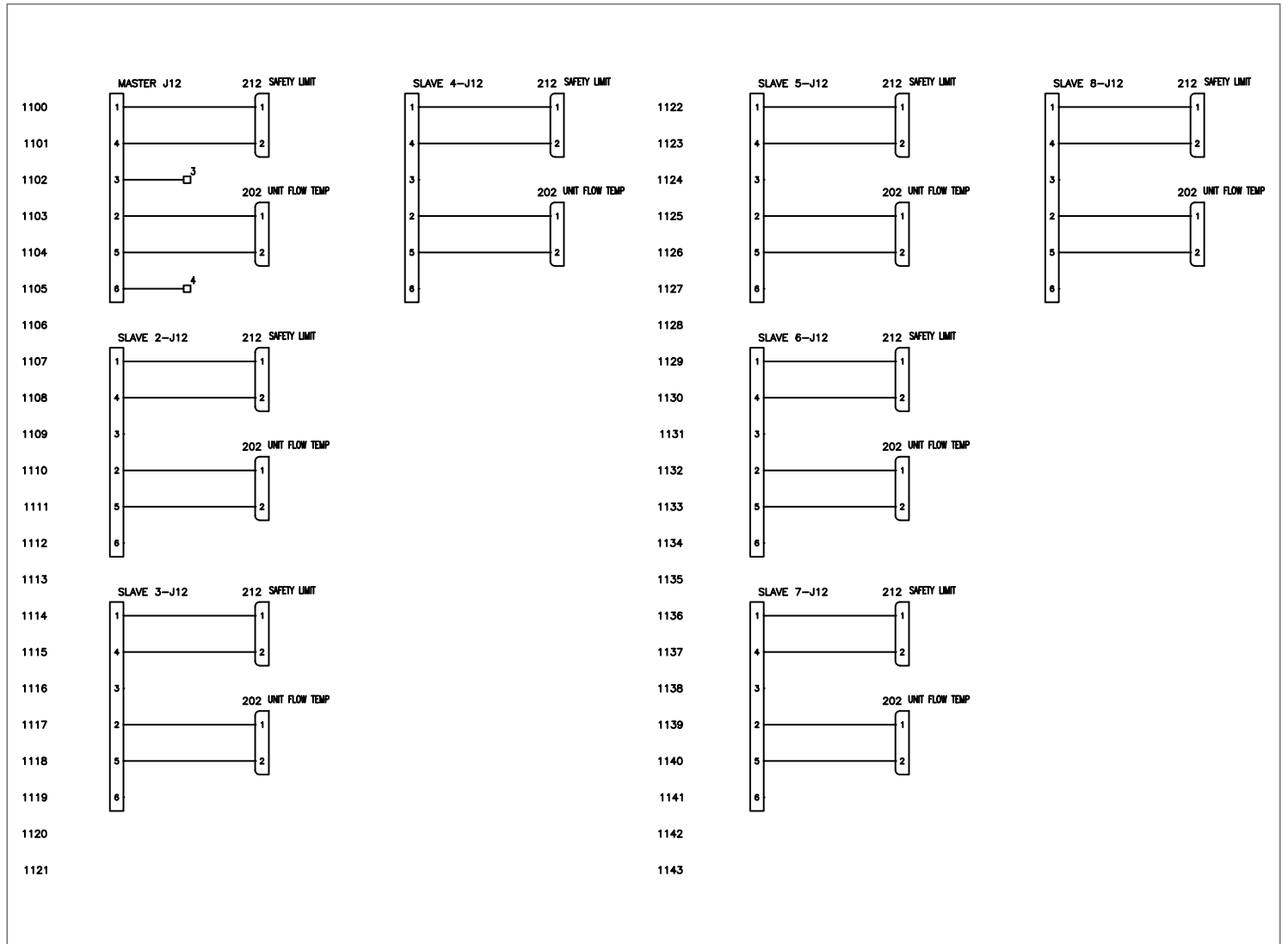

APPENDIX M – VENTING SIZE DATA

ARRAY AR 3000

	Unit	T supply / return (F°) – 176 / 140		T supply / return (F°) – 176 / 140	
		Maximum	Minimum	Maximum	Minimum
CO ₂	%	9	9	9	9
Exhaust gas mass (weight)	lb/s	0.79	0.02	0.79	0.02
Flue temperature	°F	161.6	143.6	107.6	89.6
Max. pressure at boiler exit	in. wc	1.96	0.08	1.17	0.04

ARRAY AR 4000

	Unit	T supply / return (F°) – 176 / 140		T supply / return (F°) – 176 / 140	
		Maximum	Minimum	Maximum	Minimum
CO ₂	%	9	9	9	9
Exhaust gas mass (weight)	lb/s	1.06	0.02	1.06	0.02
Flue temperature	°F	161.6	143.6	107.6	89.6
Max. pressure at boiler exit	in. wc	1.56	0.08	1.34	0.04

APPENDIX N – EXHAUST TERMINALS AND AIR INLET CLEARANCES

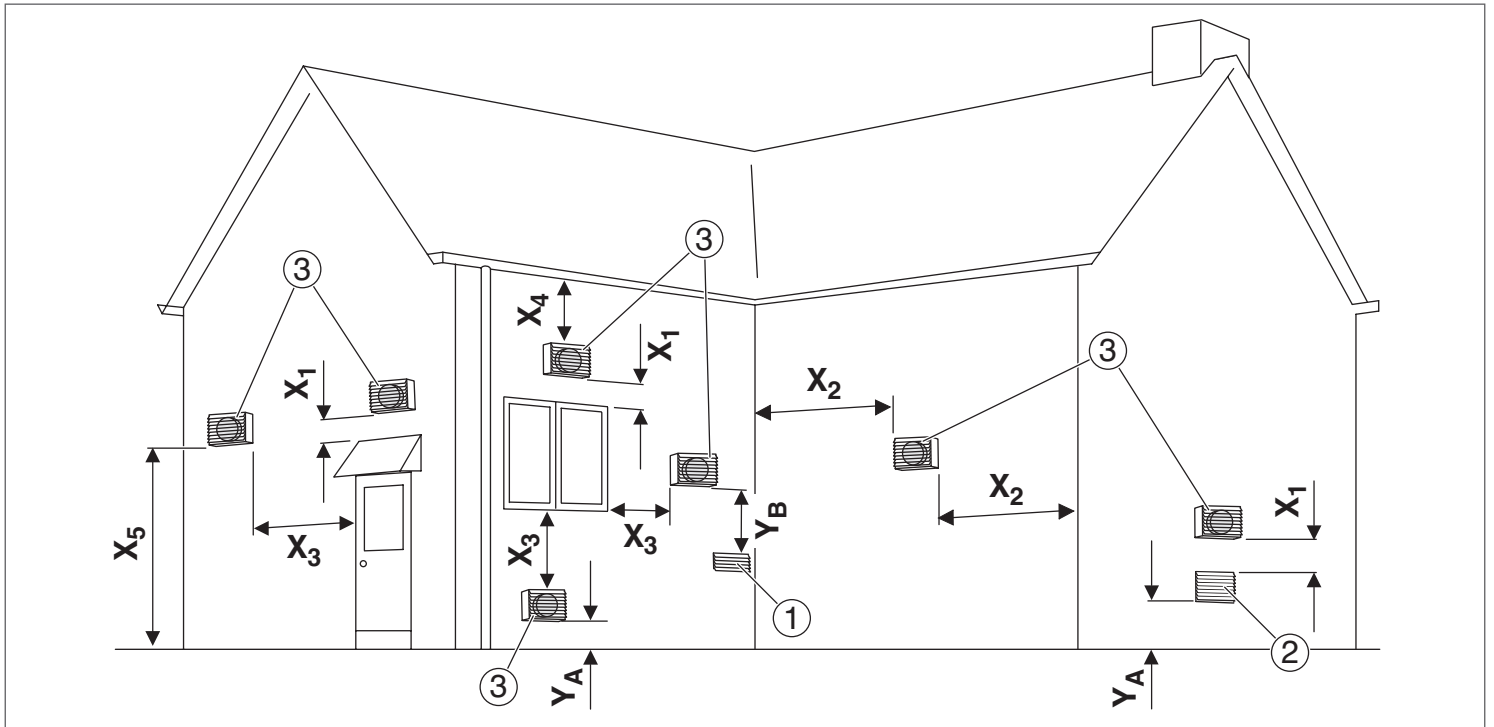

Direct vent (sealed combustion)

- 1 Forced air inlet
- 2 Gravity air inlet
- 3 Exhaust terminal
- X1 1 foot (305 mm)
- X2 See Note 1)
- X3 1 foot (305 mm) USA
3 feet (915 mm) Canada
- X4 See Note 1)
- X5 7 feet (2135 mm)
- YA At least 1 foot (305 mm) above grade or snow line
- YB Exhaust terminal must be at least:
3 feet (915 mm) above forced air inlet within
10 feet (3050 mm) horizontally – USA
6 feet (915 mm) above forced air inlet – Canada

Fan assisted appliance (Room air for combustion)

- 1 Forced air inlet
- 2 Gravity air inlet
- 3 Exhaust terminal
- X1 1 foot (305 mm)
- X2 See Note 1)
- X3 1 foot (305 mm) USA
3 feet (915 mm) Canada
- X4 See Note 1)
- X5 7 feet (2135 mm)
- YA At least 1 foot (305 mm) above grade or snow line
- YB Exhaust terminal must be at least:
3 feet (915 mm) above forced air inlet within
10 feet (3050 mm) horizontally – USA
6 feet (915 mm) above forced air inlet – Canada

It is not recommended to terminate vent above any door or window, condensate can freeze causing ice formations.

Do not use chimney as a raceway if another boiler or fireplace is vented into or through chimney.

All CPVC vent pipes must be glued, except for the flue gas adapter pipe connection.

Vent terminations must keep the following minimum clearances from electric meters, gas meters, regulators and relief equipment: 4 feet (1220 mm) [Canada 6 feet (1830 mm)] horizontally and in no case above and below, unless a horizontal distance of 4 feet (1220 mm) [Canada 6 feet (1830 mm)] is maintained.

NOTE

1) For Clearances not specified in ANSI Z223.1 / NFPA 54 or CSA B149.1 Clearance in accordance with local installation codes and the requirements of the gas supplier including the Authority having jurisdiction.

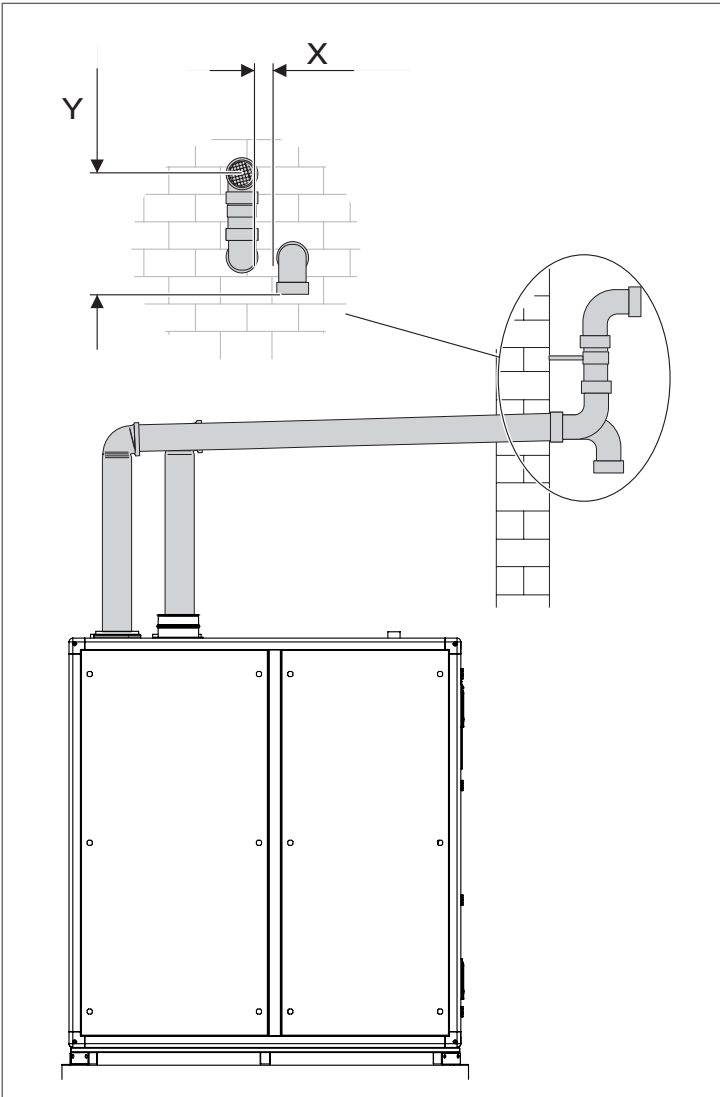

Horizontal venting system (sealed combustion):
 $X \geq 4''$ (102 mm);
 $Y \geq 12''$ (305 mm)

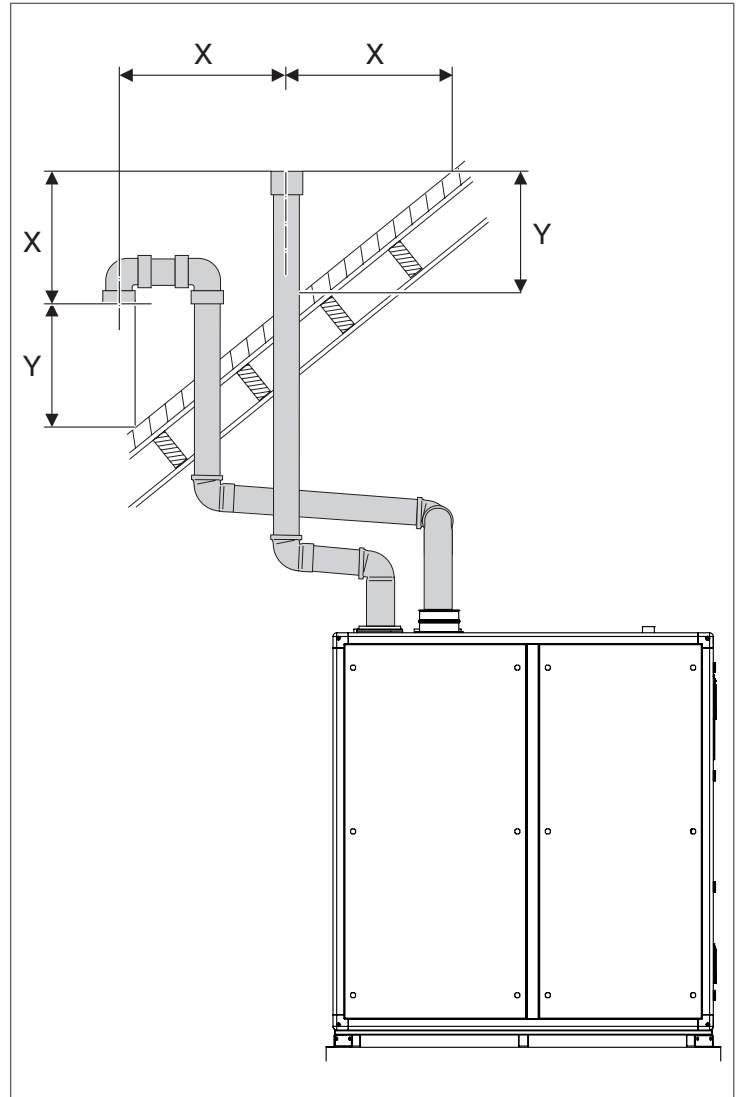

Vertical venting system (sealed combustion):
 $X > 12''$ (305 mm)
 $Y = 12''$ (305 mm) above maximum snow level or at least 24'' which-
 ever is greater

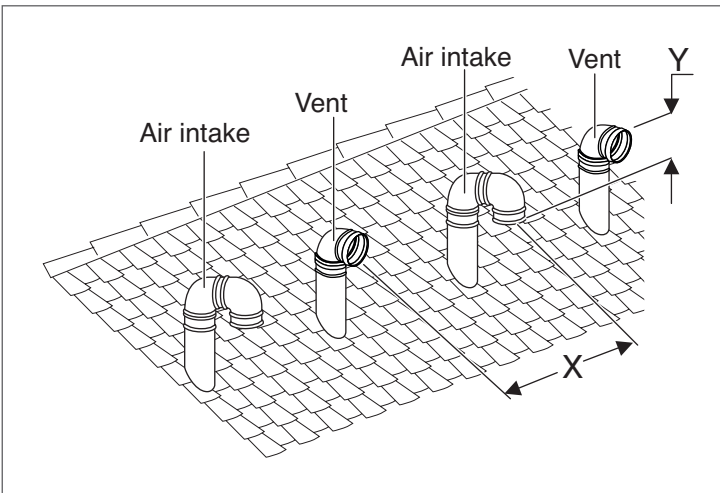

Multiple air and vent vertical termination:
 $X \geq 12''$ (305 mm);
 $Y \geq 12''$ (305 mm)

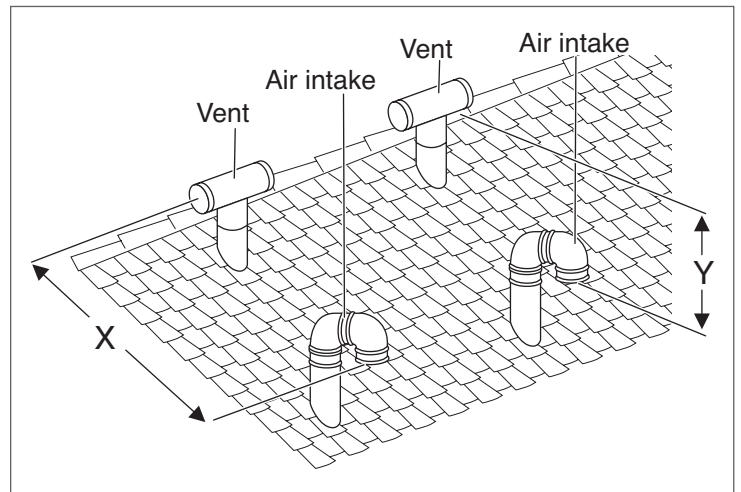

Multiple air and vent vertical termination:
 $X \geq 12''$ (305 mm);
 $Y \geq 12''$ (305 mm)

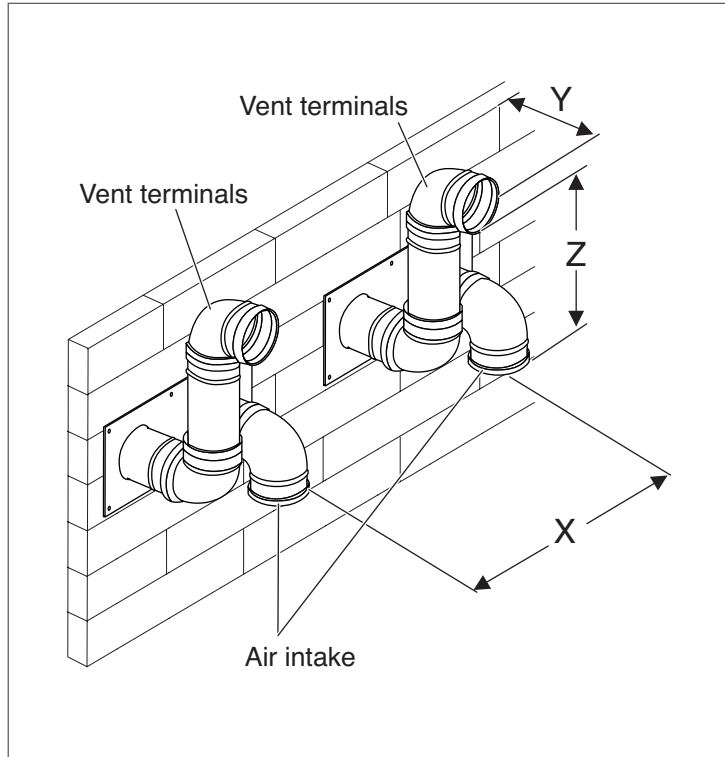

Multiple air and vent horizontal termination:
 $X \geq 12''$ (305 mm);
 $Y \leq 25''$ (635 mm)
 $Z = 12''$ to $16''$ (305 mm to 406 mm)

APPENDIX O – SENSOR RESISTANCE

SENSOR RESISTANCE TABLE

Temperature °F (°C) Testing tolerance $\pm 10\%$	Resistance [Ω]
32 (0)	27396
41 (5)	22140
50 (10)	17999
59 (15)	14716
68 (20)	12099
77 (25)	10000
86 (30)	8308
95 (35)	6936
104 (40)	5819
113 (45)	4904
122 (50)	4151
131 (55)	3529
140 (60)	3012
149 (65)	2582
158 (70)	2221
167 (75)	1918
176 (80)	1663
185 (85)	1446
194 (90)	1262
203 (95)	1105
212 (100)	970
221 (105)	855
230 (110)	755
239 (115)	669
248 (120)	594
257 (125)	529

Resistance table for:

- Module supply temperature sensor
- Module return sensor
- Module flue sensor
- Boiler supply sensor
- System temperature sensor
- Outdoor temperature sensor



RIELLO

RIELLO S.p.A.
37045 Legnago (VR)
Tel. 0442630111 - Fax 044222378

RIELLO NORTH AMERICA

35 Pound Park Road
Hingham, Massachusetts
U.S.A. 02043

2165 Meadowpine Blvd
Mississauga, Ontario
Canada L5N 6H6

www.rielloboilers.com

The manufacturer strives to continuously improve all products. Appearance, dimensions, technical specifications, standard equipment and accessories are therefore liable to modification without notice.