



- **Indoor Environment and air Quality**
- **Design Flexibility**
- **Performance**
- **Energy Efficiency**
- **Serviceability**

- For partially recessed or exposed applications
- Hot water coils, steel coils, or electric heat only options
- Optional colors, valve packages, controls and unit configurations
- Nominal CFM range of 200 to 1200 CFM

# Cabinet Heater D\*Y Series

## TECHNICAL CATALOG

---

International Environmental Corporation (IEC) works continually to improve its products. As a result, the design and specifications of each product may be changed without notice and may not be as described herein. Please contact IEC for information regarding current design and product specifications. Statements and other information contained herein are not express warranties and do not form the basis of any bargain between the parties but are merely IEC's opinion or commendation of its products. Manufacturer's standard limited warranty applies.

## Table of Contents

<b>4</b>	Portfolio
<b>5</b>	Features and Benefits
<b>6</b>	Unit Model Key
<b>7</b>	Ratings and Listings
<b>8-11</b>	Fan Performance Curves – PSC
<b>12-15</b>	Fan Performance Curves – ECM
<b>16</b>	Motor Data
<b>17-18</b>	Sound Data
<b>19</b>	Electric Heating
<b>20</b>	CUH Exploded View – DBY
<b>21-24</b>	Physical Data – DBY
<b>25</b>	CUH Exploded View – DXY
<b>26-29</b>	Physical Data – DXY
<b>30</b>	Valve Package and Coil Termination Supplement
<b>31</b>	Air Flow Arrangements
<b>32-40</b>	Standard Features and Options
<b>41</b>	Piping Packages (Typical)

# Cabinet Heater D\*Y Series

## TECHNICAL CATALOG

### Portfolio

#### Horizontal Telescoping Hideaway (DBY) 200 CFM to 1200 CFM

The Horizontal Telescoping Hideaway (DBY) cabinet heater unit is mounted fully-recessed for ceiling-recessed applications. The DBY's telescoping frame with hinged panel adapts to any ceiling type and ensures exact alignment of the panel with the ceiling. The hinged-bottom panel provides easy access to all internal components. Standard DBY units are constructed with 18 gauge galvanized steel and are provided with a galvanized finish on the cabinet and powder-coat paint finish on the bottom-access panel.



#### Horizontal Cabinet (DXY) 200 CFM to 1200 CFM

The Horizontal Cabinet (DXY) cabinet heater unit is designed specifically for exposed mounting in hotels, motels, hospitals, nursing homes, offices or other commercial establishments. With the DXY, valuable floor space is not required, and its slim, attractively-styled cabinet blends with all types of decor. Since there is no requirement for duct work or structure modifications, the DXY is ideal for retrofit applications. Standard DXY units are constructed with 18 gauge galvanized steel and are provided with a powder-coat paint finish.

## Features and Benefits

### Application Fit

- Multiple cabinet choices are available in 7 nominal CFM sizes for application in a variety of room layouts.
  - Horizontal Cabinet units (DXY) with aesthetically pleasing cabinetry offer capacities that are ideal for air conditioning in dormitories, small apartments, schools and many other applications. Front supply, bottom or rear return are available.
  - Horizontal Telescoping Hideaway units with painted access panel (DBY) allows smooth fit up to plaster or sheet rock ceilings. Standard units include bottom louvered return air with the filter located in the access panel.

### Design Flexibility

- Standard hydronic heat coils or electric heat only systems are available to match the space heating loads.
- 85 Control Board offers enhanced controls solutions with capability for connectivity to building BAS.
- Standard and high capacity hydronic coils are available to match the heating loads of the space.
- Optional powder-paint finish colors and grille selections will complement most décors (exposed units).
- Optional rear return are constructed with a solid bottom panel.
- Customizable cabinetry makes these units ideal for renovation jobs or where special sizes are required to fit oversized valves and control packages.
- Optional airflow configuration (front supply, bottom supply, rear return or bottom return) to meet certain design limitations.
- Outside air connections are available to meet ventilation requirements and reduce field labor.
- Wide variety of factory assembled valve packages (hot water coils only) to meet desired controls specifications.
- Wide variety of optional insulation materials are available to address IAQ concerns.

### Ease of Installation

- Factory assembled valve packages minimize piping work at the job site (shipped loose for field mounting).
- Optional remote mounted thermostat, service switches and fusing minimize the electrical work required on site.
- Units are tagged at the factory for clear identification on job site.

### Ease of Service

- All components are accessible by simply removing the access panel.
- Filters can be replaced without tools or by opening the bottom panels on exposed units.
- Blower assembly easily removed from the rear or bottom of coil for service and cleaning.

### Quality and Safety

- Every unit is tested and inspected at the factory for trouble free start-up.
- ETL listed for safety compliance to UL 1995, US & Canada
- All hydronic coils are pressure tested to 350 psig.

# Cabinet Heater D\*Y Series

## TECHNICAL CATALOG

### Unit Model Key

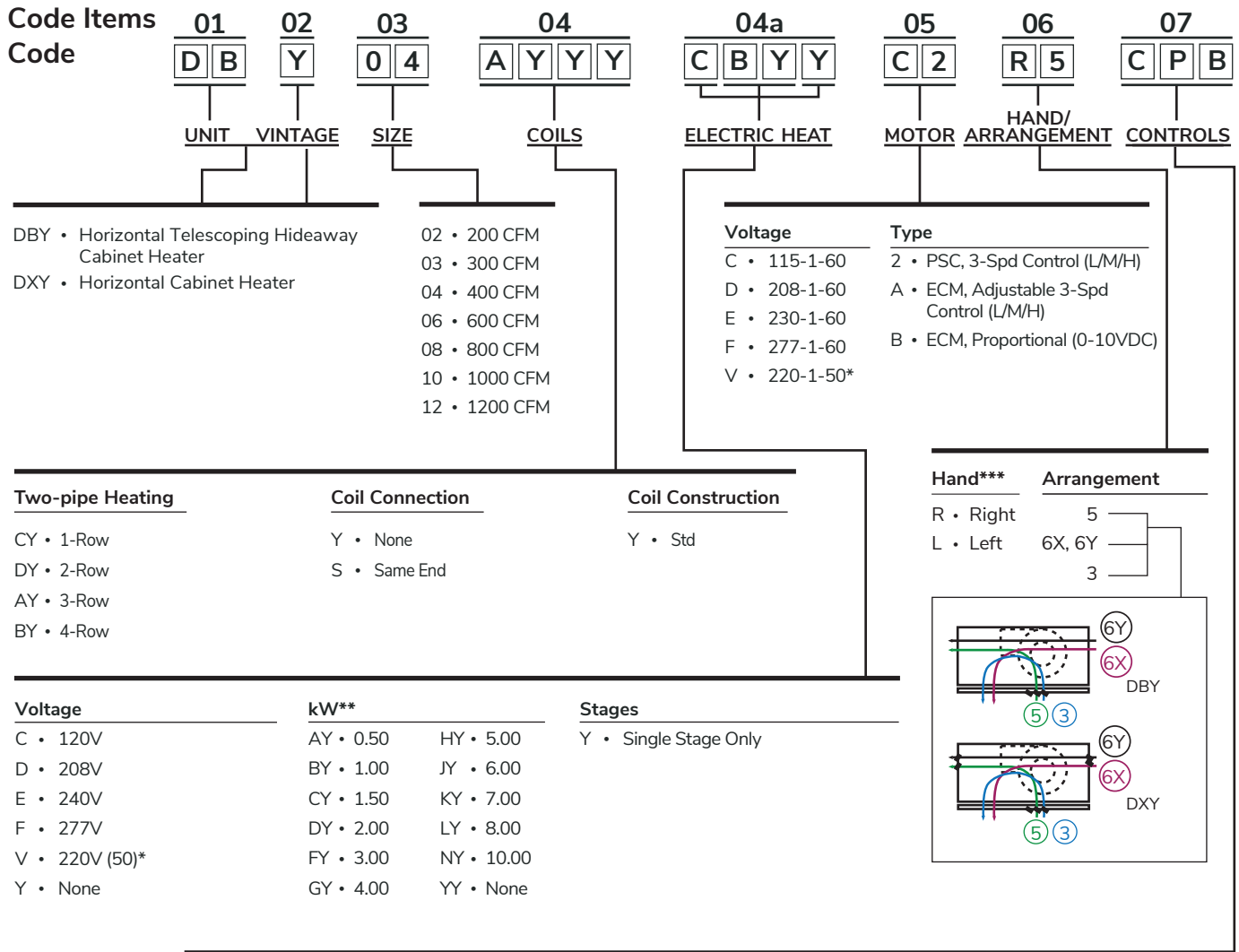

Voltage**	System	Thermostat
B • 24 V	<b>Manual Fan Operation</b>	A • Basic Electronic Wall Series, 155, Vertical
C • 120V	A • Standard Unit Mount (Switch Only)	B • Basic Electronic Wall Series, 155, Horizontal
D • 208V		P • Basic 24V Digital, 7-Day Programmable
E • 240V	<b>Function Control</b>	N • Basic 24V Digital, Non-Programmable
F • 277V	G • 2 Pipe Heat Only	F • Premium 24V Digital, 7-Day Programmable/ BACnet with Proportional Fan/ Valves Option
V • 220V (50)*	E • Electric Heat Only	G • Premium 24V Digital BACnet with Proportional Fan/ Valves Option
		W • Venture 24V Wi-Fi Programmable

\* Consult factory for 50 Hz applications.  
 \*\* Note that kW's depend on voltage and unit size.  
 \*\*\* Standing in front of the unit, hand is determined by looking into the air supply and assigning the hand to match the location of the cooling coil connections.

### Ratings and Listings



#### C-ETL-US Listing

IEC's Horizontal D\*Y Cabinet Series units are listed by ETL. The C-ETL-US listing signifies that IEC's fan coil units have been examined by ETL and are in compliance with both the U.S. and Canadian applicable standards.

#### Standard Ratings – PSC Motors

Model	Size	Coil Rows	Air Flow Rating (SCFM)	Water Pressure Drop (ft. water)	Total Cap. (Btuh)	Power Input (Watts)
DBY, DXY	02	Electric Heat	261	NA	--	88
	02	1	302	0.3	9,328	94
	02	2	264	1.5	15,777	74
	02	3	281	3.6	21,002	91
	02	4	261	5.4	22,532	88
	03	Electric Heat	311	NA	--	95
	03	1	336	0.5	11,282	99
	03	2	336	2.5	20,327	99
	03	3	323	5.3	24,875	97
	03	4	311	8.2	27,257	95
	04	Electric Heat	458	NA	--	141
	04	1	527	1.1	16,980	150
	04	2	527	5.6	30,516	150
	04	3	492	11.6	37,000	145
	04	4	458	17.4	39,745	141
	06	Electric Heat	521	NA	--	148
	06	1	606	1.8	21,365	169
	06	2	606	1.6	36,412	169
	06	3	587	3.2	44,781	166
	06	4	568	5.3	49,537	162
	08	Electric Heat	676	NA	--	185
	08	1	761	2.9	27,070	228
	08	2	761	2.7	46,052	228
	08	3	733	5.3	56,258	223
	08	4	706	8.7	61,873	219
	10	Electric Heat	872	NA	--	259
	10	1	1067	6.5	38,451	301
	10	2	1067	5.9	65,247	301
	10	3	998	1.7	75,136	293
	10	4	998	1.7	75,136	293
	12	Electric Heat	1183	NA	--	336
	12	1	1330	9.9	46,880	422
	12	2	1330	9.0	79,879	422
	12	3	1275	2.8	94,644	413
	12	4	1219	4.6	104,609	404

#### Standard Ratings – EC Motors

Model	Size	Coil Rows	Air Flow Rating (SCFM)	Water Pressure Drop (ft. water)	Total Cap. (Btuh)	Power Input (Watts)
DBY, DXY	02	Electric Heat	257	NA	--	57
	02	1	301	0.3	9,309	64
	02	2	301	1.7	17,240	64
	02	3	281	3.6	21,002	61
	02	4	262	5.5	22,606	57
	03	Electric Heat	319	NA	--	74
	03	1	340	0.5	11,363	81
	03	2	340	2.6	20,492	81
	03	3	327	5.4	25,117	81
	03	4	313	8.3	27,408	81
	04	Electric Heat	482	NA	--	123
	04	1	518	1.1	16,808	119
	04	2	518	5.5	30,167	119
	04	3	500	11.8	37,464	119
	04	4	482	18.6	41,512	119
	06	Electric Heat	571	NA	--	135
	06	1	606	1.8	21,365	141
	06	2	606	1.6	36,412	141
	06	3	603	3.3	45,734	141
	06	4	600	5.7	51,920	141
	08	Electric Heat	694	NA	--	159
	08	1	754	2.9	26,918	157
	08	2	754	2.6	45,763	157
	08	3	739	5.4	56,618	160
	08	4	724	9.0	63,226	164
	10	Electric Heat	1038	NA	--	270
	10	1	1073	9.0	38,583	235
	10	2	1073	5.9	65,497	235
	10	3	1042	1.8	77,704	238
	10	4	1011	3.1	86,813	242
	12	Electric Heat	1225	NA	--	305
	12	1	1337	9.9	47,029	294
	12	2	1337	9.1	80,162	294
	12	3	1277	2.8	94,759	296
	12	4	1217	4.6	104,463	298

NOTES: 1. Ratings are based on 80°F DB and 67°F WB EAT, 45°F EWT, 10°F water temperature rise, high fan speed, motor voltage 115/1/60, and airflow under dry coil conditions.  
 2. For all application ratings, use IEC's computer selection program, the quick-selection ratings provided in this catalog, or contact your local IEC representative.

### Fan Performance Curves – PSC

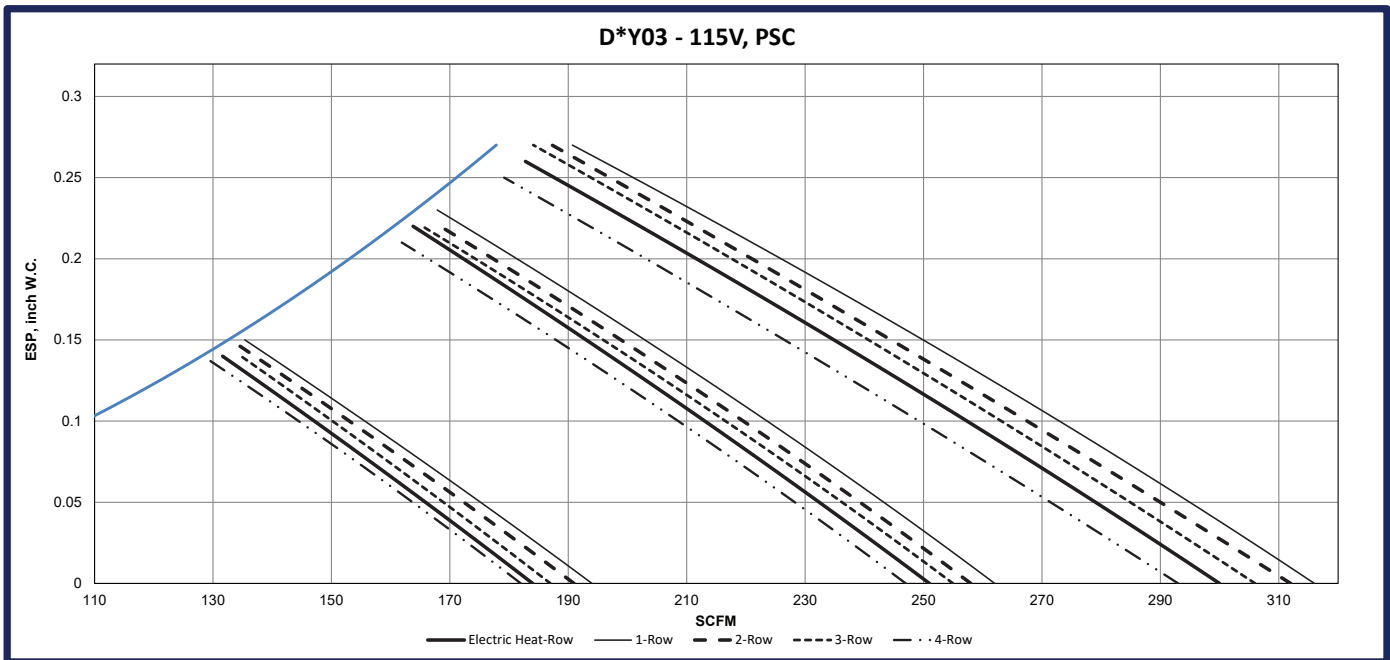
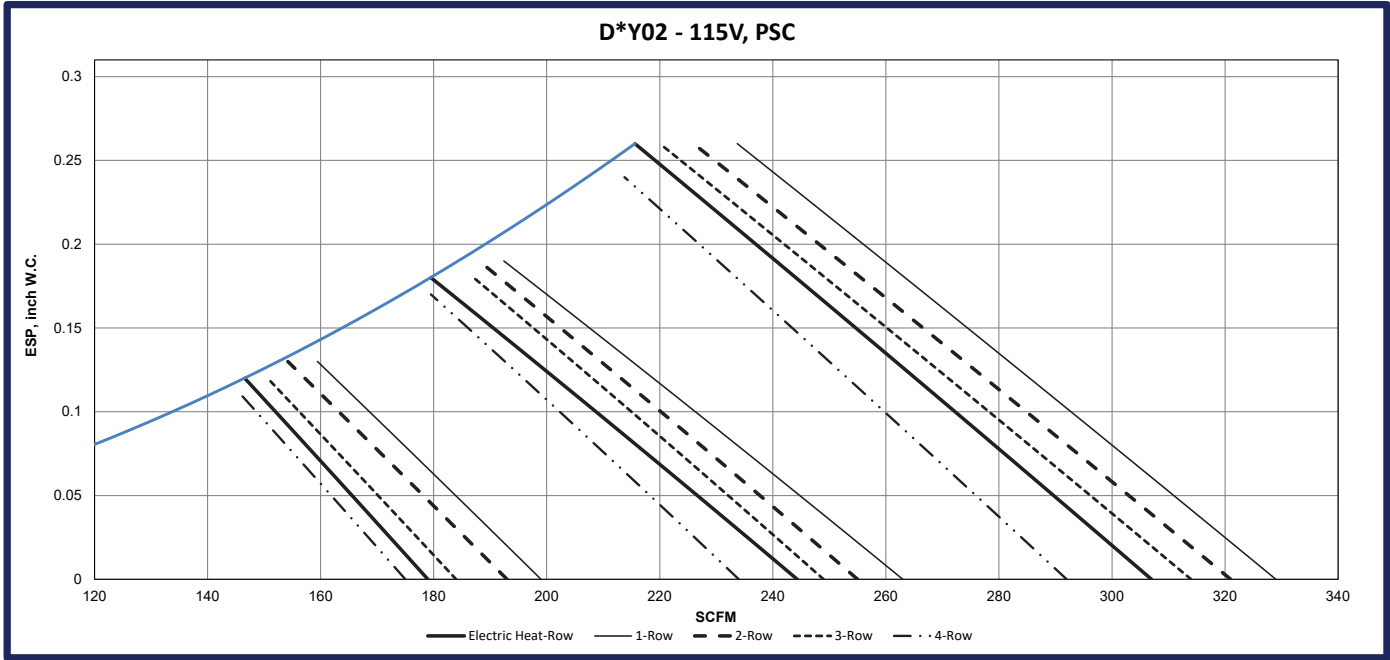



**Fan Performance Curves – PSC, Cont'd.**

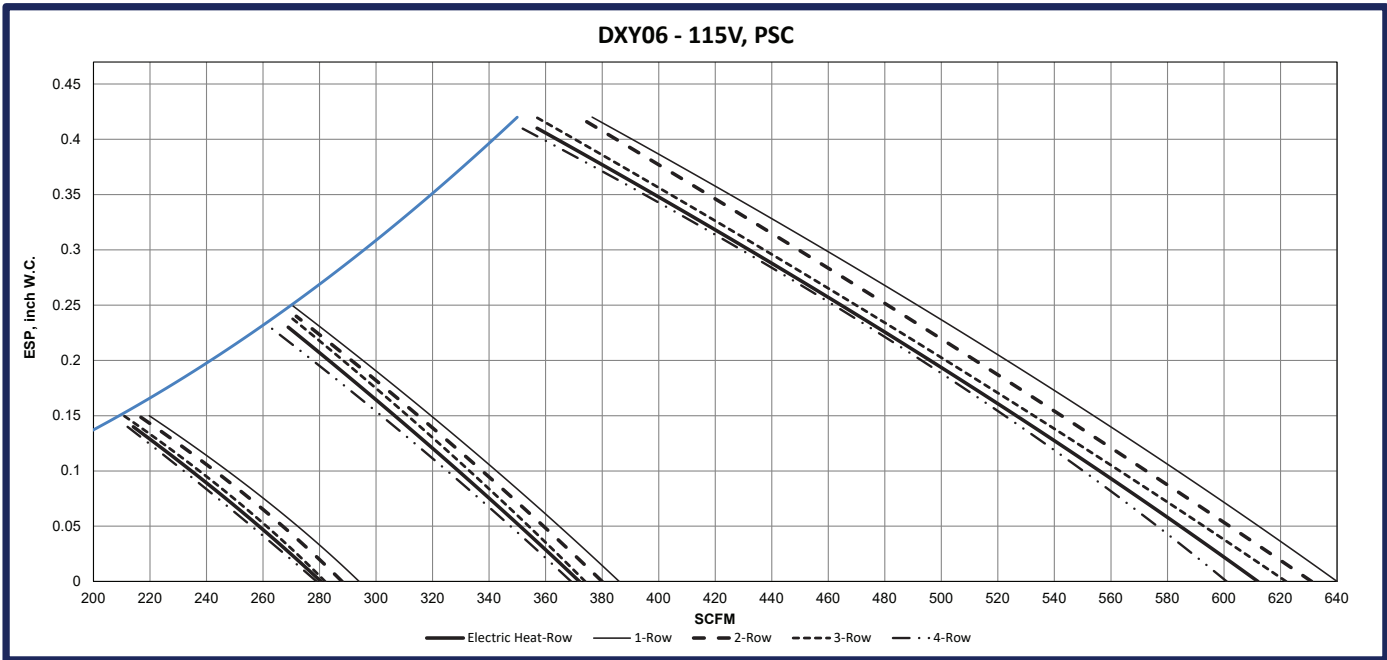
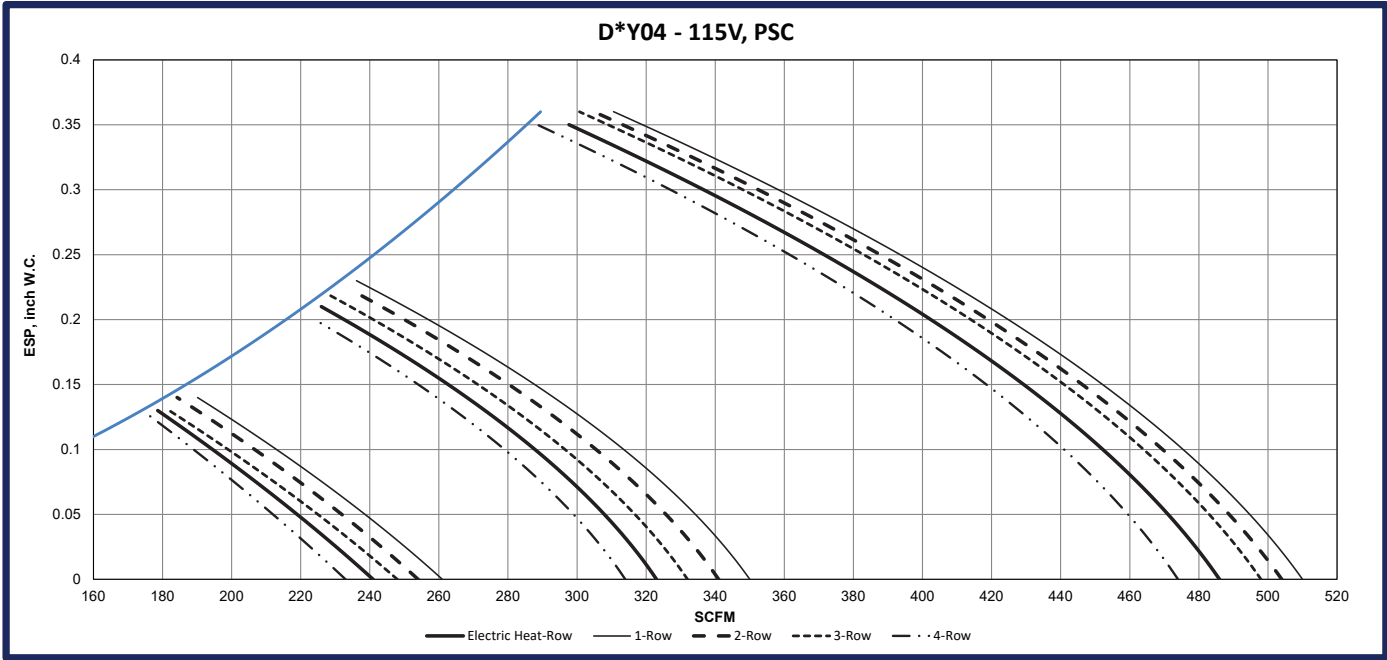

### Fan Performance Curves – PSC, Cont'd.

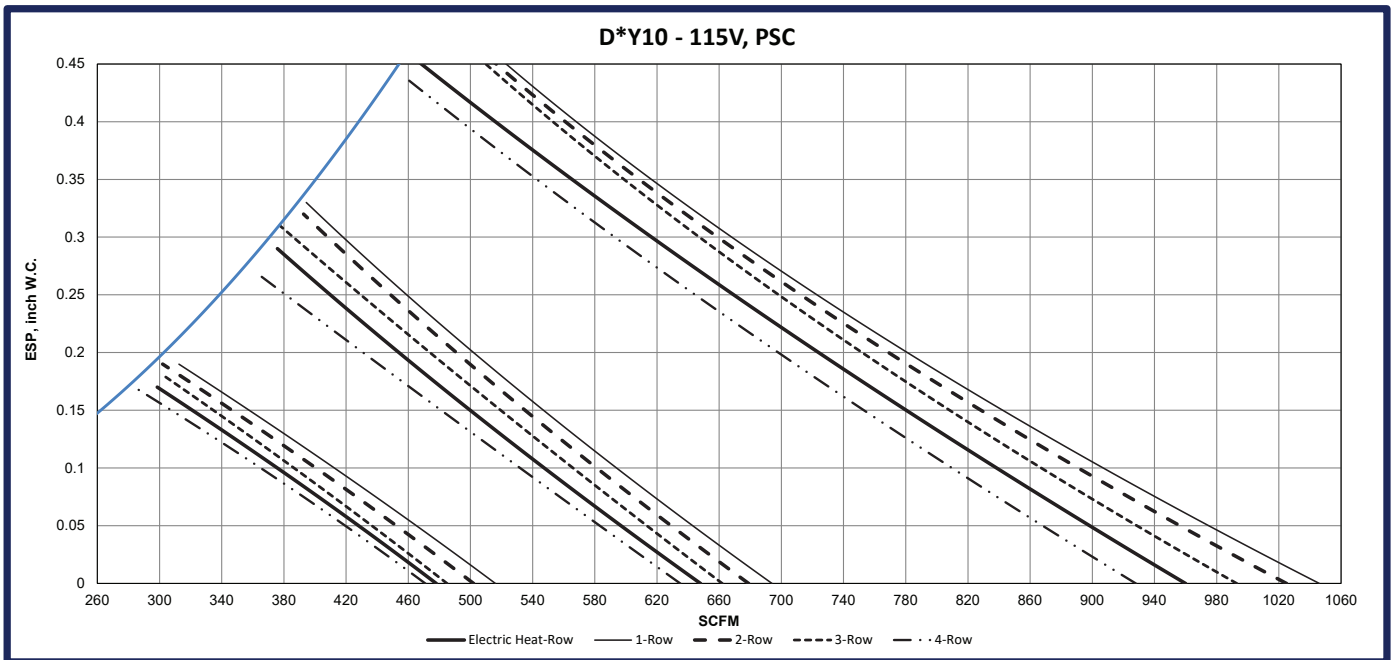
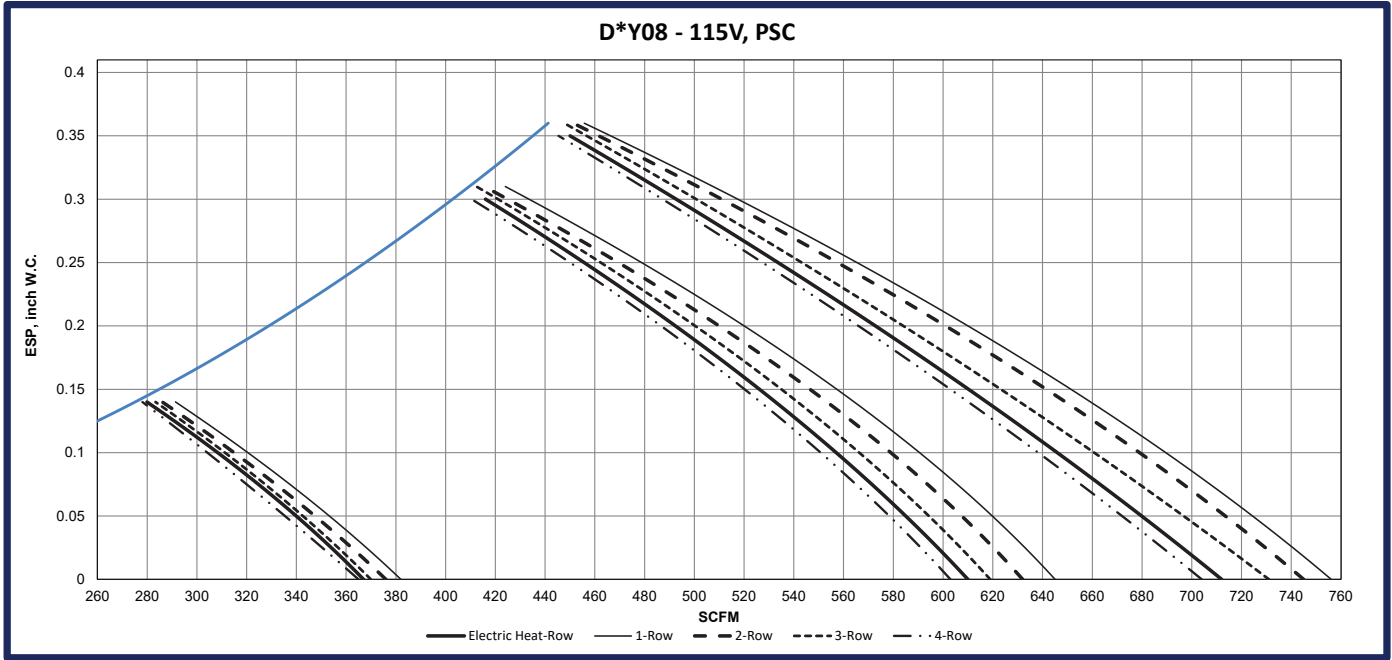

### Fan Performance Curves – PSC, Cont'd.

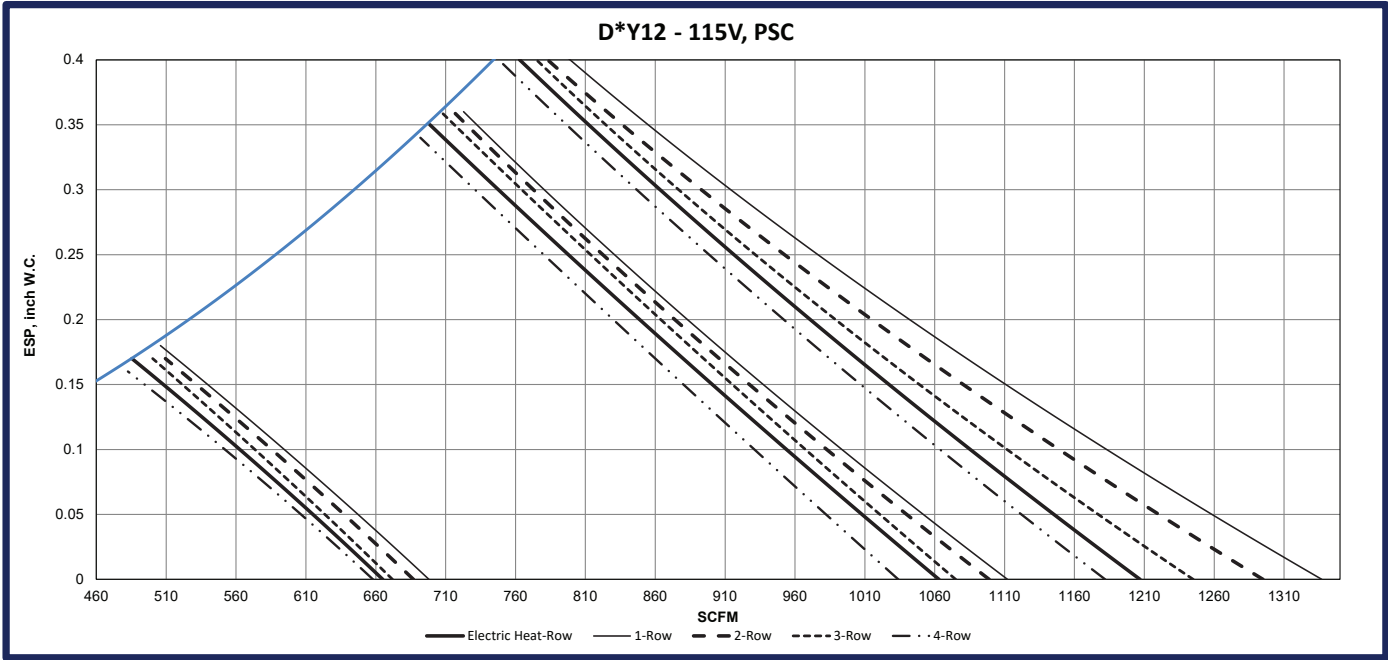

### Fan Performance Curves – ECM

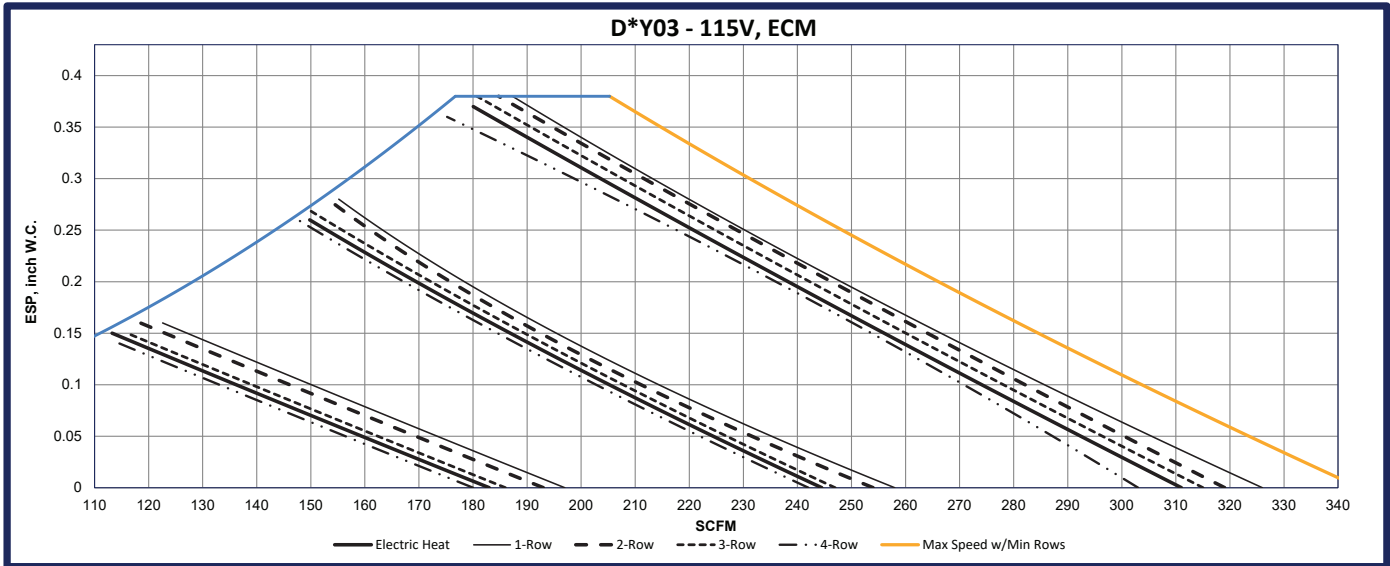
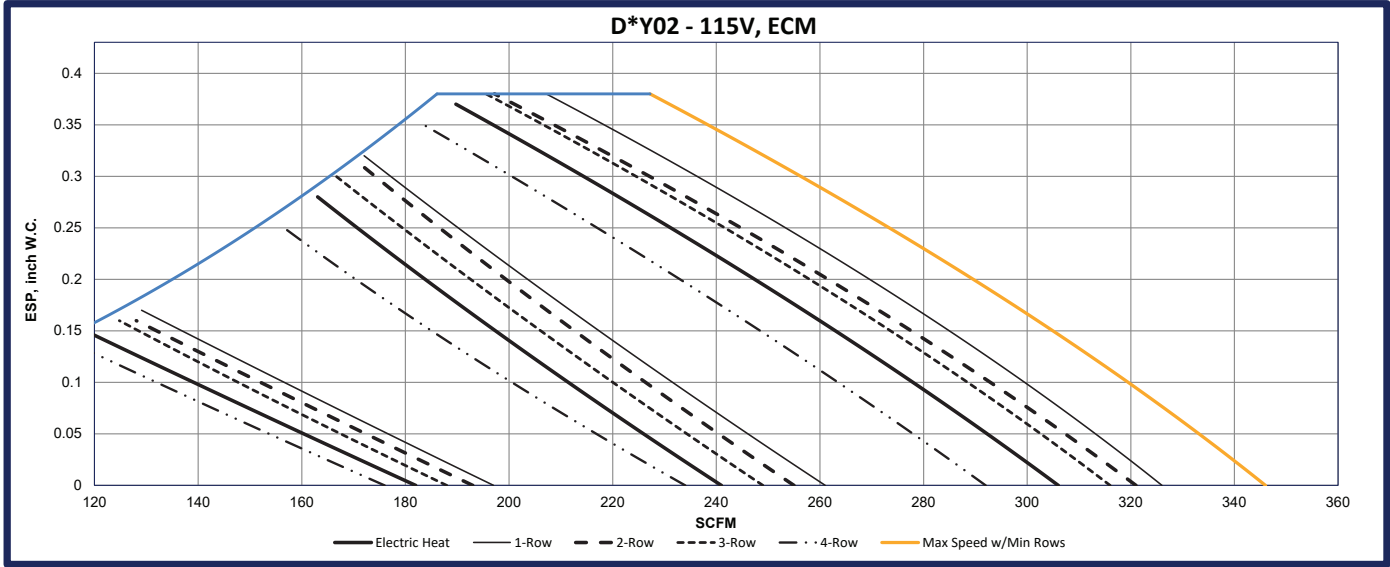

**Fan Performance Curves – ECM, Cont'd.**

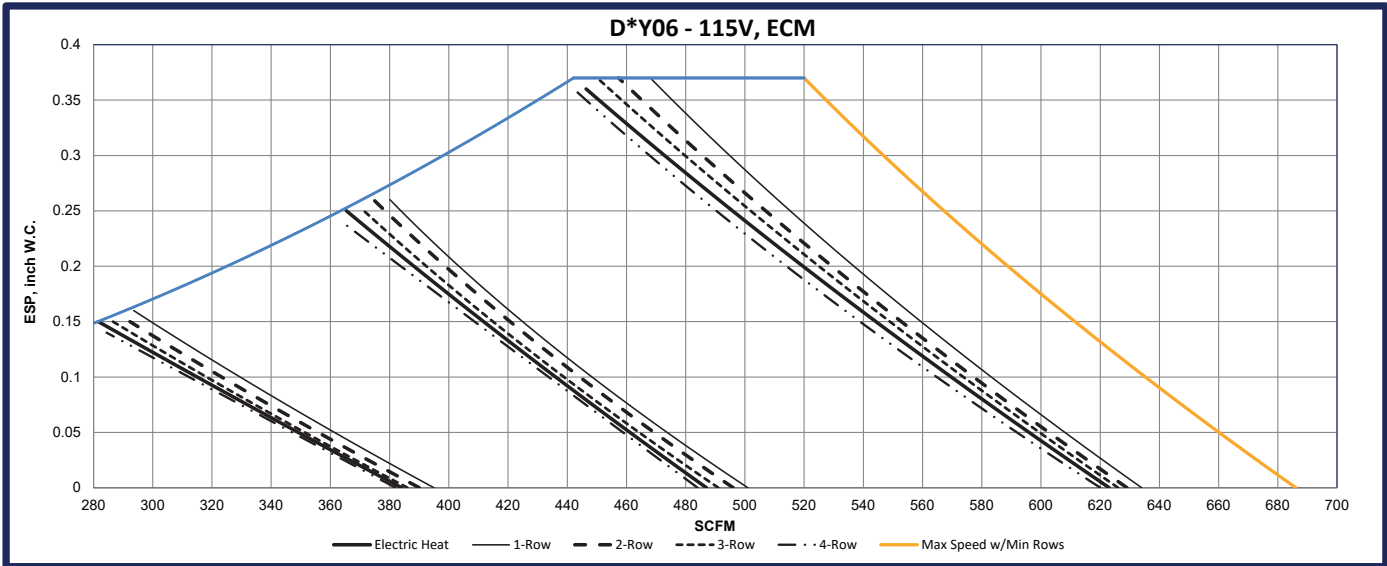
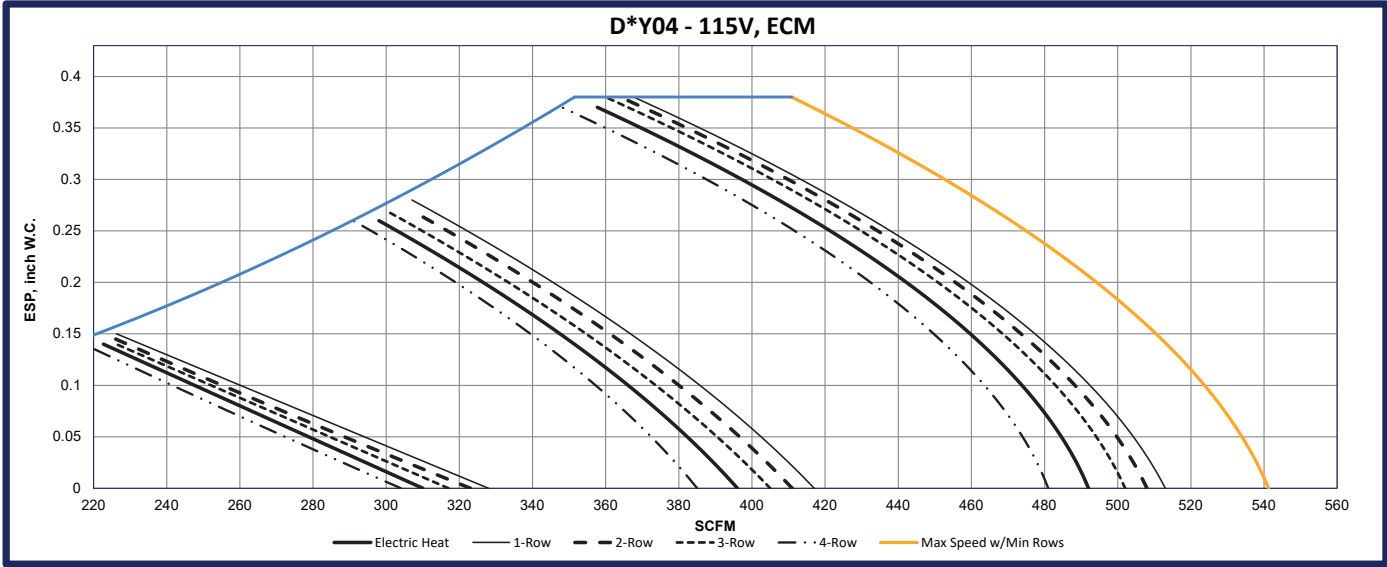

### Fan Performance Curves – ECM, Cont'd.

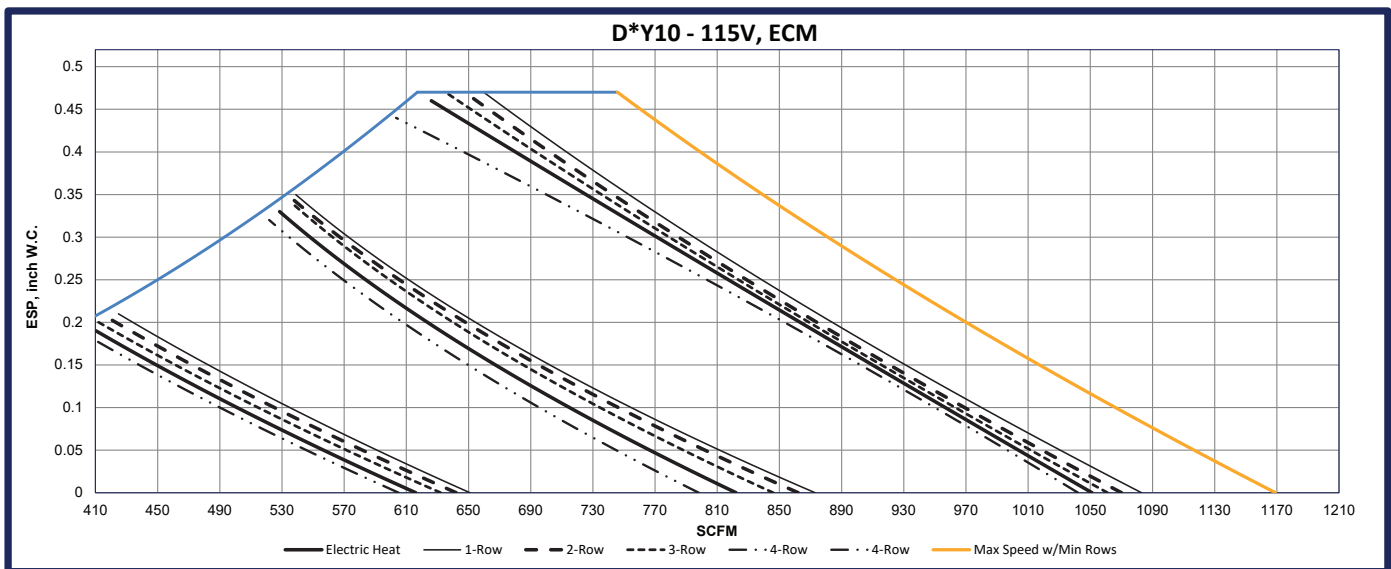
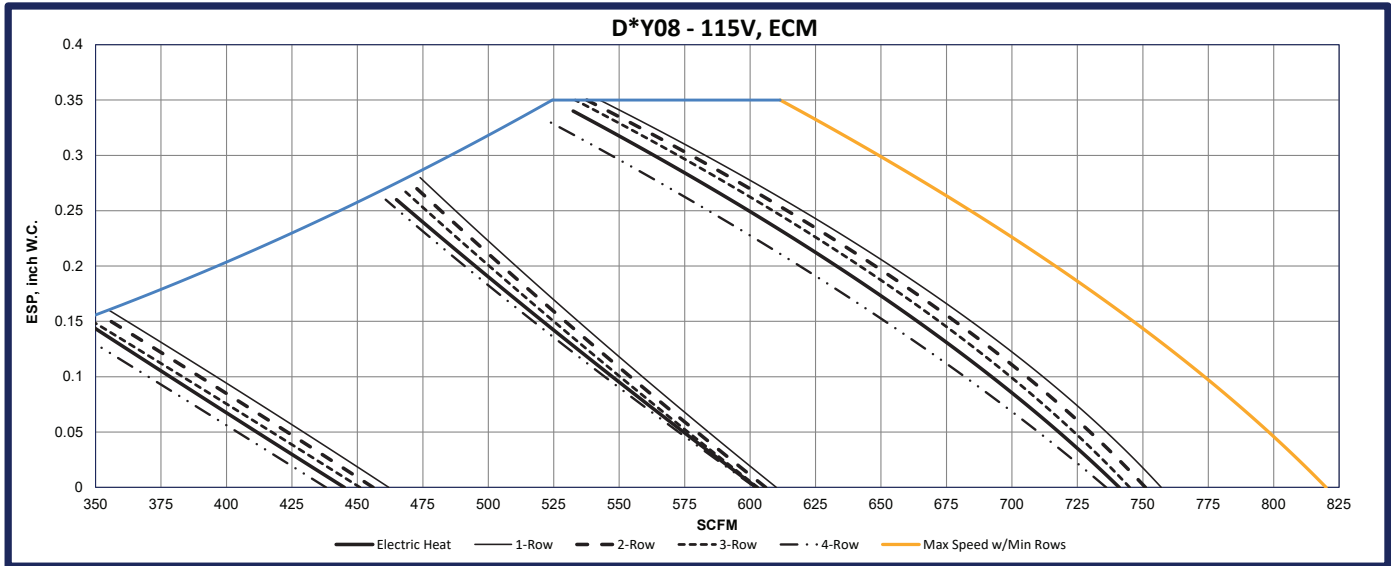

**Fan Performance Curves – ECM, Cont'd.**

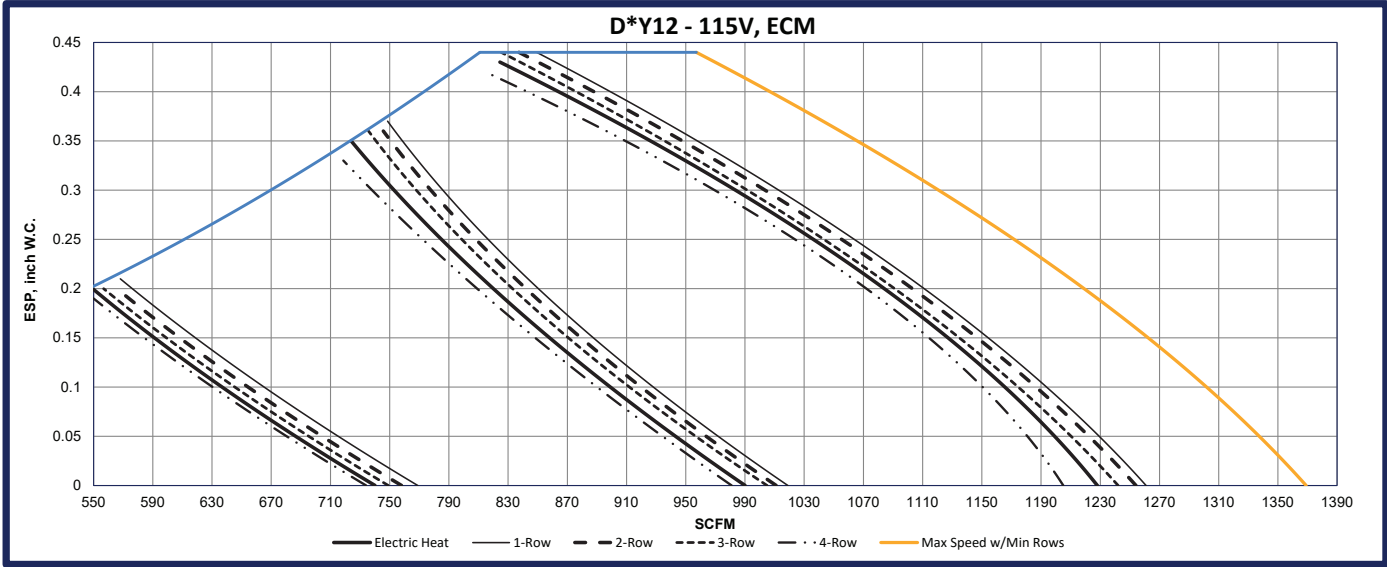

# Cabinet Heater D\*Y Series

## TECHNICAL CATALOG

## Motor Data

### Thermal Overload Protection and ETL Listing

All permanently lubricated split-capacitor motors furnished by IEC contain internal thermal-overload protection. The overload automatically resets when the temperature returns to a safe limit. Electronics Testing Laboratories, Inc. approves the motor and thermal overload combination at locked rotor conditions only.

### PSC Motor Performance Data

Voltage	Fan Speed	Unit Size	02	03	04	06	08	10	12
		Nominal HP	1/30	1/30	1/12	1/12	1/6	(2) 1/12	(2) 1/6
115V 60 Hz 1 Phase	High	Amps	0.53	0.83	1.40	1.40	2.50	2.80	5.00
		Watts	78	89	144	151	223	286	399
208V 60 Hz 1 Phase	High	Amps	0.48	0.48	0.69	0.69	1.30	1.38	2.60
		Watts	98	99	120	132	189	245	325
230V 60 Hz 1 Phase	High	Amps	0.48	0.48	0.69	0.69	1.30	1.38	2.60
		Watts	114	112	137	150	206	281	356
277V 60 Hz 1 Phase	High	Amps	0.35	0.35	0.69	0.69	0.91	1.38	1.82
		Watts	104	112	143	155	245	288	426

NOTES: 1. Total unit motor Amps and Watts are shown.  
2. Consult factory for 50 Hz applications.

### EC Motor Performance Data

Voltage	Unit Size	02	03	04	06	08	10	12
	Nominal HP	1/7	1/7	1/6	1/6	1/6	(2) 1/6	(2) 1/6
120V	Rated Motor FLA	2.3	2.3	2.4	2.4	2.4	(2) 2.4	(2) 2.4
	Max Program Current	1.3	1.5	2.1	1.9	2.4	2.0, 2.0	2.4, 2.4
208-240V	Rated Motor FLA	1.4	1.4	1.6	1.6	1.6	1.6, 1.6	1.6, 1.6
	Max Program Current	0.8	0.9	1.4	1.3	1.6	1.3, 1.3	1.6, 1.6
277V	Rated Motor FLA	1.2	1.2	1.3	1.3	1.3	1.3, 1.3	1.3, 1.3
	Max Program Current	0.7	0.8	1.1	1	1.3	1.1, 1.1	1.3, 1.3



## Sound Data

### DBY Sound Power Data

UNIT SIZE	RATING	FAN SPEED	CFM	SOUND POWER LEVEL, Lw (dB reference one picowatt)							A-wgt (dBA)
				125 Hz	250 Hz	500 Hz	1K Hz	2K Hz	4K Hz	8K Hz	
2	CASING RADIATED	H	270	60	54	51	48	43	38	37	53
		M	170	55	51	44	39	35	31	34	47
		L	135	53	49	39	34	29	29	34	44
	DUCTED DISCHARGE	H	270	52	52	53	47	46	40	37	54
		M	170	47	45	45	39	37	31	34	46
		L	135	46	43	40	33	31	29	34	42
3	CASING RADIATED	H	290	63	54	52	49	44	40	38	54
		M	205	59	47	44	40	35	31	34	47
		L	155	55	42	39	34	29	29	34	43
	DUCTED DISCHARGE	H	290	59	54	54	51	47	41	38	56
		M	205	55	46	47	41	37	31	34	48
		L	155	51	42	42	35	31	29	34	43
4	CASING RADIATED	H	540	70	58	55	52	48	43	39	58
		M	360	62	49	46	42	37	32	34	50
		L	250	54	42	38	32	30	30	34	42
	DUCTED DISCHARGE	H	540	64	57	59	55	50	44	39	60
		M	360	55	49	51	52	46	36	36	50
		L	250	48	42	43	35	30	28	33	43
6	CASING RADIATED	H	680	65	59	57	52	48	45	42	59
		M	445	57	50	47	41	37	33	34	49
		L	330	52	43	40	34	29	29	34	43
	DUCTED DISCHARGE	H	680	63	58	59	56	50	46	42	60
		M	445	57	49	50	45	39	33	34	50
		L	330	53	43	42	37	30	29	34	44
8	CASING RADIATED	H	765	65	61	58	54	51	48	45	60
		M	670	63	58	55	51	47	44	41	57
		L	410	55	47	44	38	34	31	34	46
	DUCTED DISCHARGE	H	765	63	61	61	58	53	50	46	63
		M	670	60	58	58	54	50	46	42	59
		L	410	52	47	47	41	36	32	35	48
10	CASING RADIATED	H	1105	68	64	59	55	52	48	45	62
		M	730	64	55	51	45	41	37	35	54
		L	490	59	48	43	36	31	30	34	47
	DUCTED DISCHARGE	H	1105	65	62	64	60	55	50	46	65
		M	730	63	54	56	50	44	38	36	56
		L	490	58	46	47	40	33	30	34	48
12	CASING RADIATED	H	1225	68	65	61	57	53	50	45	63
		M	1140	67	63	59	54	51	47	42	61
		L	745	59	54	50	44	40	35	34	52
	DUCTED DISCHARGE	H	1225	65	63	65	60	57	52	47	66
		M	1140	63	61	63	58	54	50	44	64
		L	745	56	54	55	48	43	37	35	54

- NOTES: 1. Unit Test Configuration: Bottom Return/ Front Supply, 3 Row 10 FPI Coil, 0.0" ESP @ High Speed, 115VAC PSC Motor, 1/2" dual density fiberglass insulation.  
2. Casing Radiated tested in accordance with AHRI 350-2008: 4.2.2.3 Casing radiated with free inlet, Sound Rating of Ducted Air Moving and Conditioning Equipment.  
3. Ducted Discharge tested in accordance with AHRI 350-2008: 4.2.2.1 Ducted discharge, Sound Rating of Ducted Air Moving and Conditioning Equipment.  
4. Sound power data is expressed in decibels, dB RE:  $1 \times 10^{-12}$  w (picowatts).

# Cabinet Heater D\*Y Series

## TECHNICAL CATALOG

### Sound Data, Cont'd.

#### DXY Sound Power Data

UNIT SIZE	RATING	FAN SPEED	CFM	SOUND POWER LEVEL, Lw (dB reference one picowatt)						A-wgt (dBA)	
				125 Hz	250 Hz	500 Hz	1K Hz	2K Hz	4K Hz		8K Hz
2	CASING RADIATED	H	220	60	58	56	54	49	44	39	59
		M	160	54	51	49	45	39	33	31	50
		L	130	50	46	44	39	33	26	31	45
3	CASING RADIATED	H	265	61	58	57	54	49	45	41	59
		M	185	54	50	49	44	40	33	32	50
		L	135	52	45	44	39	33	27	31	45
4	CASING RADIATED	H	480	68	63	63	60	55	50	44	65
		M	310	64	53	54	48	42	35	32	55
		L	205	58	46	45	38	31	26	31	47
6	CASING RADIATED	H	605	67	64	63	59	54	51	45	64
		M	385	59	54	53	46	41	34	32	53
		L	280	55	48	46	39	31	26	31	47
8	CASING RADIATED	H	690	67	67	66	62	58	55	51	67
		M	600	66	64	62	58	54	50	46	64
		L	355	57	52	51	45	39	33	32	51
10	CASING RADIATED	H	925	69	68	68	66	60	55	50	70
		M	620	64	58	60	55	48	42	34	60
		L	415	59	51	52	44	37	29	31	52
12	CASING RADIATED	H	1180	70	70	69	66	61	58	53	71
		M	1060	70	68	67	63	58	54	49	68
		L	665	64	57	57	50	44	38	32	57

- NOTES: 1. Unit Test Configuration: Bottom Return/ Front Supply, 3 Row 10 FPI Coil, 0.0" ESP @ High Speed, 115VAC PSC Motor, 1/2" dual density fiberglass insulation.  
 2. Casing Radiated tested in accordance with AHRI 350-2008: 4.2.2.3 Casing radiated with free inlet, Sound Rating of Ducted Air Moving and Conditioning Equipment.  
 3. Sound power data is expressed in decibels, dB RE:  $1 \times 10^{-12}$  w (picowatts).

## Electric Heating

Electric heaters are available for the following applications:

### Total Electric Heat

Total electric heat eliminates the requirement for a boiler. Individual room controls can be supplied for either manual or automatic changeover.

### Construction

The heater coils of high-grade resistance wire are supported by ceramic insulators on plated steel brackets. These heat elements are suspended directly in front of the fan outlet. A heat shield protects the internal heater from any debris. High limit thermal cutouts protect the heater in the event of air failure. There are many special applications and control sequences for electric heat. For special applications, please consult the factory.

### Electric Heater Selection

Voltage	kW	Unit Size							
		02	03	04	06	08	10	12	
120V	0.5	•	•	-	-	-	-	-	
	1.0	•	•	•	•	•	-	-	
	1.5	•	•	•	•	•	-	-	
	2.0	•	•	•	•	•	•	•	
	3.0	-	•	•	•	•	•	•	
208V	0.5	•	•	-	-	-	-	-	
	1.0	•	•	•	•	•	-	-	
	1.5	•	•	•	•	•	-	-	
	2.0	•	•	•	•	•	•	•	
	3.0	-	•	•	•	•	•	•	
	4.0	-	-	-	•	•	•	•	
	5.0	-	-	-	• Note 5	•	•	•	
	6.0	-	-	-	• Note 5	• Note 5	•	•	
	8.0	-	-	-	-	-	• Note 5	• Note 5	
240V 277V	0.5	•	•	-	-	-	-	-	
	1.0	•	•	•	•	•	-	-	
	1.5	•	•	•	•	•	-	-	
	2.0	•	•	•	•	•	•	•	
	3.0	-	•	•	•	•	•	•	
	4.0	-	-	-	•	•	•	•	
	5.0	-	-	-	• Note 5	•	•	•	
	6.0	-	-	-	• Note 5	• Note 5	•	•	
	8.0	-	-	-	-	-	• Note 5	• Note 5	
	10.0	-	-	-	-	-	-	• Note 5	

- NOTES: 1. All heaters are single stage and single phase.  
 2. Heaters over 48 Amps are subdivided and fused.  
 3. Electric Heating Capacities (BTUH) = Heater kW x 3413.  
 4. Consult factory for 50 Hz applications.  
 5. High and medium speed only.

# Cabinet Heater D\*Y Series

## TECHNICAL CATALOG

### CUH Exploded View – DBY

#### Horizontal Telescoping Cabinet Heater, Hydronic Heat, Front Supply

ITEM	DESCRIPTION
1	COIL ASSY
2	BOT PNL ASSY
3	CNTL PKG
4	TOP WRPR ASSY
5	TOP WRPR SPRT BRKT
6	BOT PAN GALV
7	REAR PNL ASSY DUCT
8	TOP PNL ASSY SLD
9	FRNT PNL DUCT
10	SIDE PNL ASSY
11	SIDE PNL ASSY
12	FLTR TA 7 x 38 X 1
13	TELE ASSY
14	MOT BLO DECK ASSY
15	GROM 0.75 X 0.38

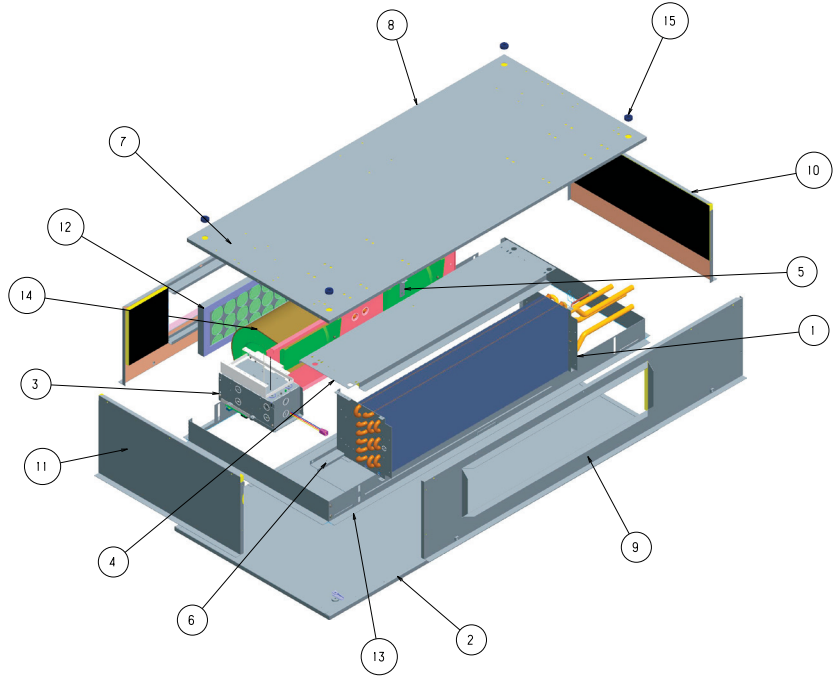

#### Horizontal Telescoping Cabinet Heater, Electric Heat, Front Supply

ITEM	DESCRIPTION
1	BOT PNL ASSY
2	CNTL PKG
3	TOP WRPR SPRT BRKT
4	REAR PNL ASSY DUCT
5	TOP PNL ASSY SLD
6	FRNT PNL DUCT
7	HTR ASSY
8	HEATER PLNM ASSY
9	SIDE PNL ASSY
10	SIDE PNL ASSY
11	FLTR TA 7 x 38 X 1
12	TELE ASSY
13	MOT BLO DECK ASSY
14	GROM 0.75 X 0.38

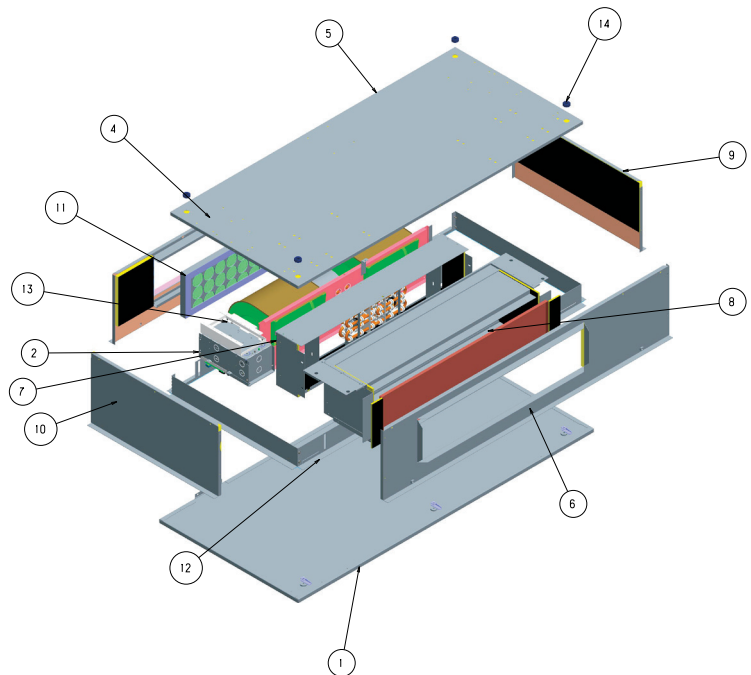

### Physical Data – DBY

#### DBY – Horizontal Telescoping Cabinet Heater, Hydronic Heat, Front Supply

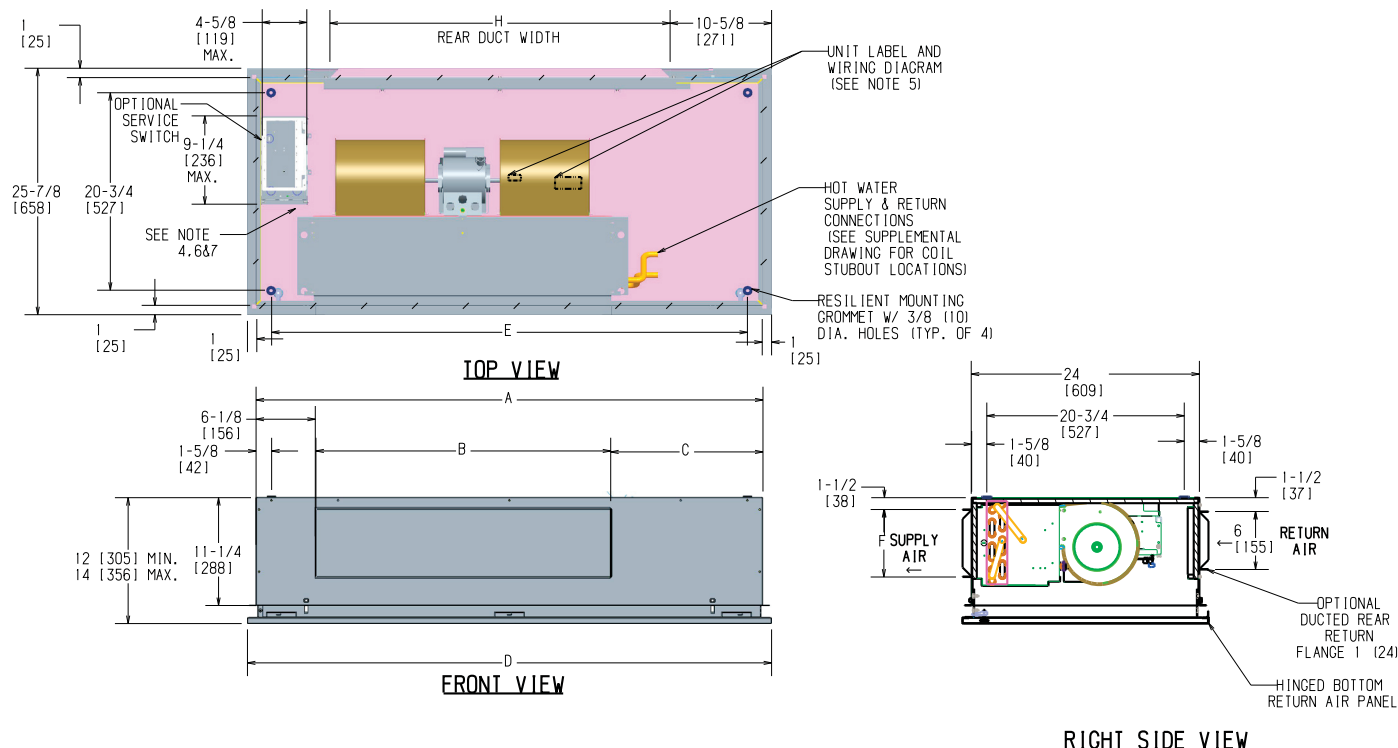

Unit Model	Dimensions - Inches (Millimeters)							Quantity/Unit		Unit Weight*
	A	B	C	D	E	F	H	Blower	Motor	
DBY02	35 (889)	16 (406)	12-3/4 (324)	37 (940)	32 (813)	6 (152)	18-3/4 (476)	1	1	55
DBY03	35 (889)	20 (508)	8-3/4 (225)	37 (940)	32 (813)	6 (152)	18-3/4 (476)	1	1	60
DBY04	41 (1041)	26 (660)	8-3/4 (225)	43 (1092)	38 (965)	6 (152)	24-3/4 (629)	2	1	70
DBY06	53 (1346)	31 (787)	15-3/4 (400)	55 (1397)	50 (1270)	7 (179)	35-3/4 (908)	2	1	82
DBY08	53 (1346)	38 (965)	8-3/4 (225)	55 (1397)	50 (1270)	7 (179)	35-3/4 (908)	2	1	95
DBY10	75 (1905)	52 (1321)	16-3/4 (425)	77 (1956)	72 (1829)	7 (179)	49-3/4 (1264)	4	2	135
DBY12	75 (1905)	60 (1524)	8-3/4 (225)	77 (1956)	72 (1829)	7 (179)	49-3/4 (1264)	4	2	154

- NOTES:**
1. RH shown, LH opposite.
  2. All dimensions are +/- .25 (6). Drawing not to scale.
  3. Product specifications are subject to change without notice.
  4. Control box size and position may vary (consult factory).
  5. Position may vary.
  6. Service access is located on the front of the control box.
  7. Knockouts on the bottom and side of the control box for incoming power connections.
  8. Typical size 06 unit shown with 1-Motor and 2-BLWR - Refer to table for variation.
  9. See Valve Package Supplemental for piping termination.
  10. Field connection pipes will be shipped loose with valve packages.

Drawing is provided for reference only. Dimensions may vary with options ordered. Consult IEC website for submittal drawings.

# Cabinet Heater D\*Y Series

## TECHNICAL CATALOG

### Physical Data – DBY, Cont'd.

#### DBY – Horizontal Telescoping Cabinet Heater, Electric Heat, Front Supply

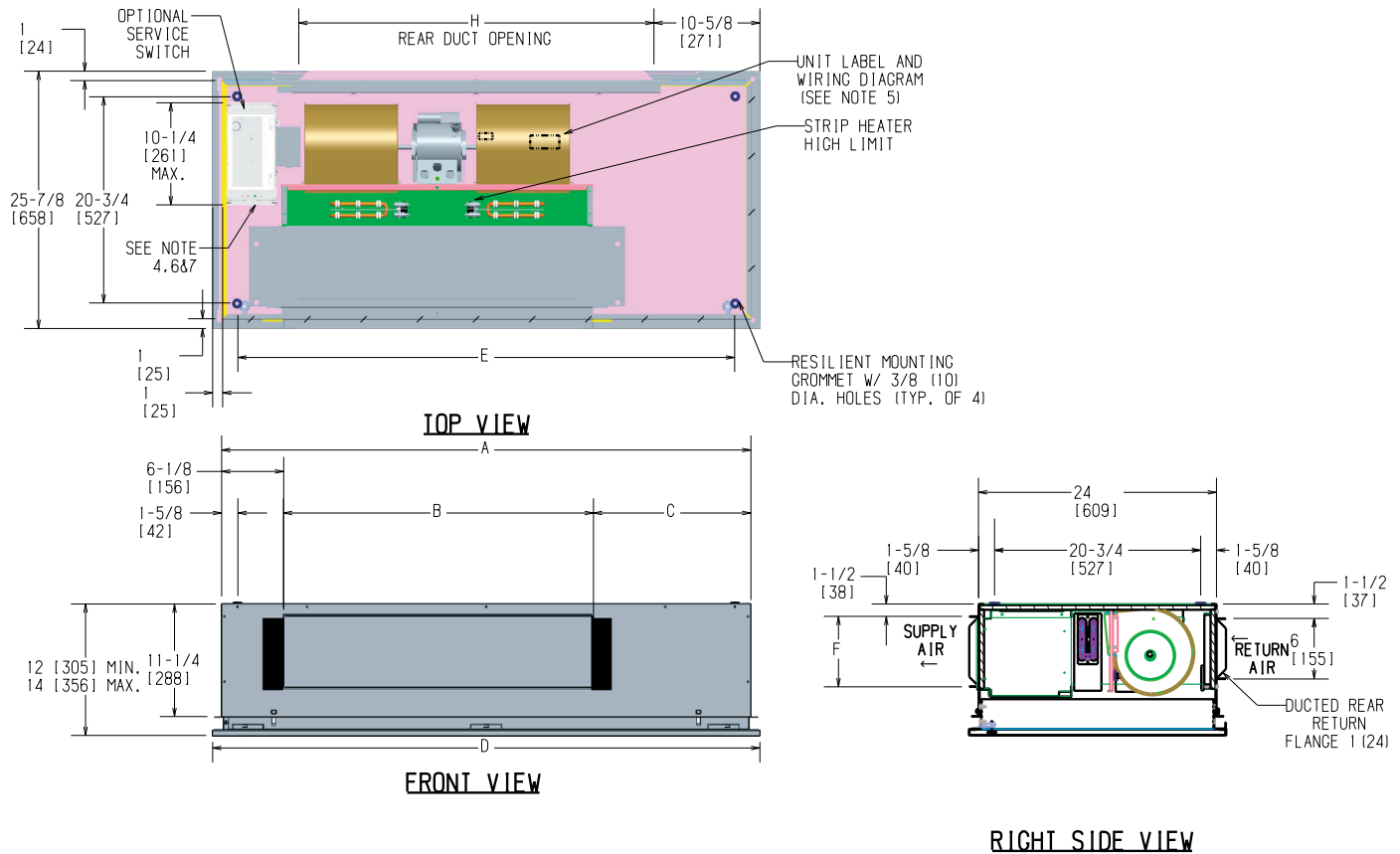

Unit Model	Dimensions - Inches (Millimeters)							Quantity/Unit		Unit Weight*
	A	B	C	D	E	F	H	Blower	Motor	
DBY02	35 (889)	16 (406)	12-3/4 (324)	37 (940)	32 (813)	6 (152)	18-3/4 (476)	1	1	55
DBY03	35 (889)	20 (508)	8-3/4 (225)	37 (940)	32 (813)	6 (152)	18-3/4 (476)	1	1	60
DBY04	41 (1041)	26 (660)	8-3/4 (225)	43 (1092)	38 (965)	6 (152)	24-3/4 (629)	2	1	70
DBY06	53 (1346)	31 (787)	15-3/4 (400)	55 (1397)	50 (1270)	7 (179)	35-3/4 (908)	2	1	82
DBY08	53 (1346)	38 (965)	8-3/4 (225)	55 (1397)	50 (1270)	7 (179)	35-3/4 (908)	2	1	95
DBY10	75 (1905)	52 (1321)	16-3/4 (425)	77 (1956)	72 (1829)	7 (179)	49-3/4 (1264)	4	2	135
DBY12	75 (1905)	60 (1524)	8-3/4 (225)	77 (1956)	72 (1829)	7 (179)	49-3/4 (1264)	4	2	154

- NOTES:
1. RH shown, LH opposite.
  2. All dimensions are +/- .25 (6). Drawing not to scale.
  3. Product specifications are subject to change without notice.
  4. Control box size and position may vary (consult factory).
  5. Position may vary.
  6. Service access is located on the front of the control box.
  7. Knockouts on the bottom and side of the control box for incoming power connections.
  8. Typical size 06 unit shown with 1-Motor and 2-BLWR - Refer to table for variation.
  9. See Valve Package Supplemental for piping termination.
  10. Field connection pipes will be shipped loose with valve packages.

Drawing is provided for reference only.  
Dimensions may vary with options ordered.  
Consult IEC website for submittal drawings.

### Physical Data – DBY, Cont'd.

#### DBY – Horizontal Telescoping Cabinet Heater, Hydronic Heat, Bottom Supply

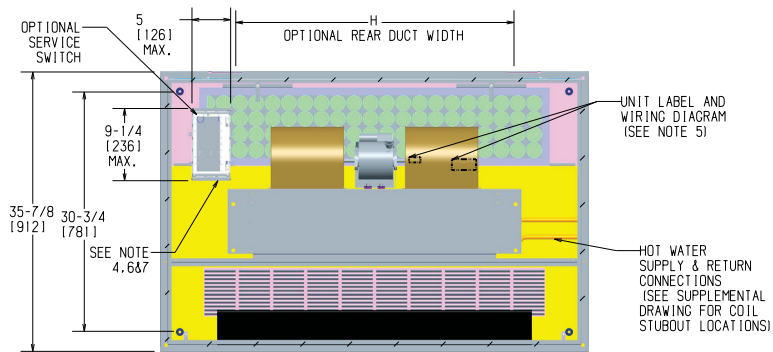

**TOP VIEW**

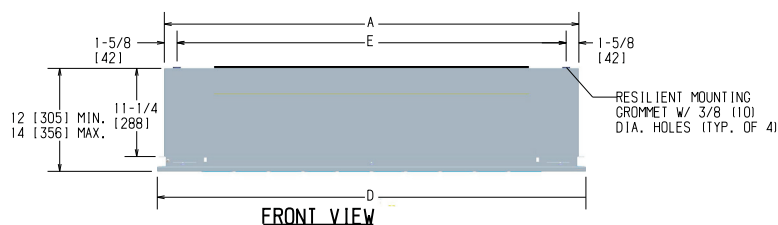

**FRONT VIEW**

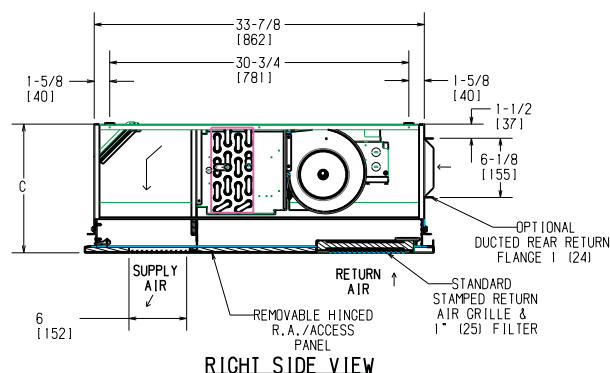

**RIGHT SIDE VIEW**

Unit Model	Dimensions - Inches (Millimeters)				Quantity/Unit		Unit Weight*
	A	D	E	H	Blower	Motor	
DBY02	35 (889)	37 (940)	32 (813)	18-3/4 (476)	1	1	55
DBY03	35 (889)	37 (940)	32 (813)	18-3/4 (476)	1	1	60
DBY04	41 (1041)	43 (1092)	38 (965)	24-3/4 (629)	2	1	70
DBY06	53 (1346)	55 (1397)	50 (1270)	35-3/4 (908)	2	1	82
DBY08	53 (1346)	55 (1397)	50 (1270)	35-3/4 (908)	2	1	95
DBY10	75 (1905)	77 (1956)	72 (1829)	49-3/4 (1264)	4	2	135
DBY12	75 (1905)	77 (1956)	72 (1829)	49-3/4 (1264)	4	2	154

- NOTES:**
- LH shown, RH opposite.
  - All dimensions are +/- .25 (6). Drawing not to scale.
  - Product specifications are subject to change without notice.
  - Control box size and position may vary (consult factory).
  - Position may vary.
  - Service access is located on the front of the control box.
  - Knockouts on the bottom and side of the control box for incoming power connections.
  - Typical size 06 unit shown with 1-Motor and 2-BLWR - Refer to table for variation.
  - See Valve Package Supplemental for piping termination.
  - Field connection pipes will be shipped loose with valve packages.

Drawing is provided for reference only. Dimensions may vary with options ordered. Consult IEC website for submittal drawings.

# Cabinet Heater D\*Y Series

## TECHNICAL CATALOG

### Physical Data – DBY, Cont'd.

#### DBY – Horizontal Telescoping Cabinet Heater, Electric Heat, Bottom Supply

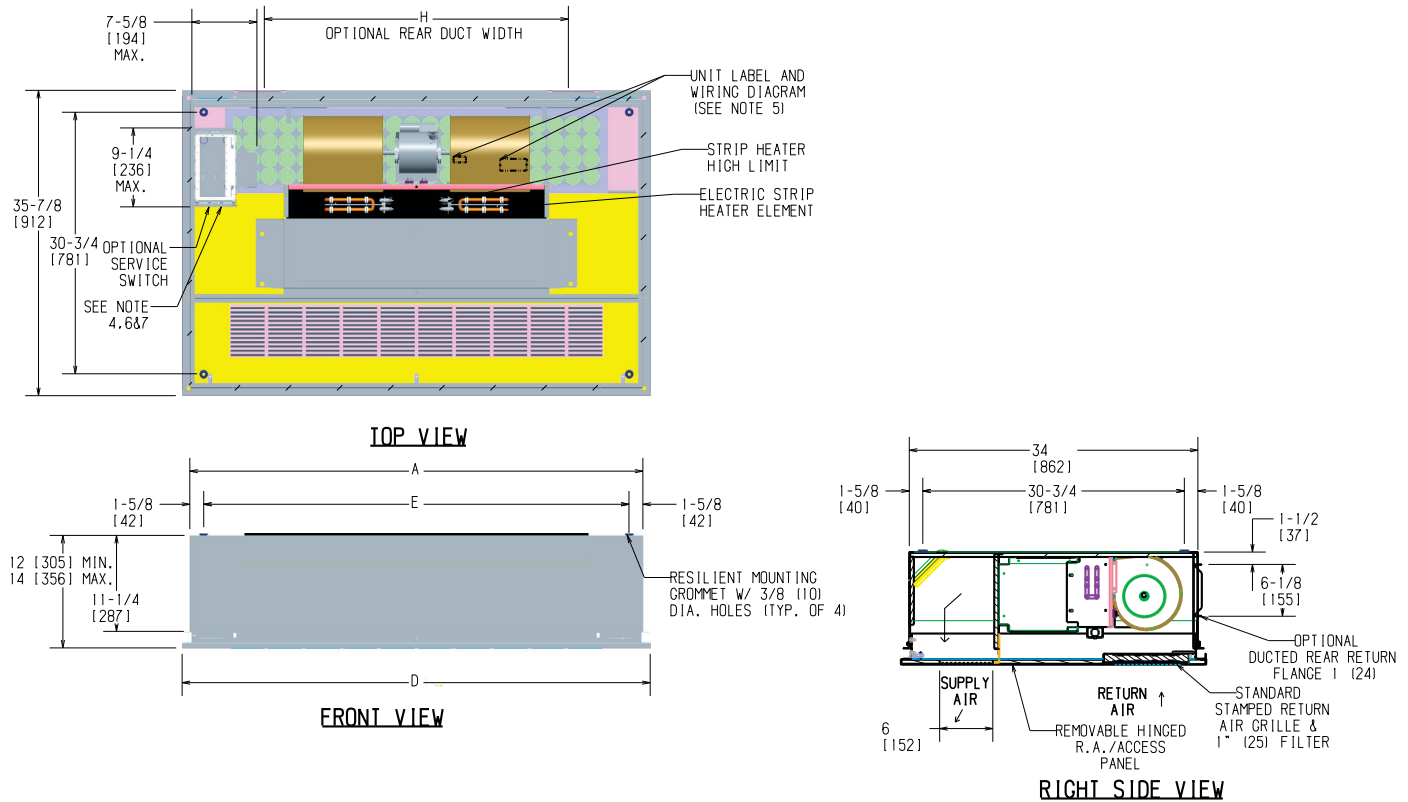

Unit Model	Dimensions - Inches (Millimeters)				Quantity/Unit		Unit Weight*
	A	D	E	H	Blower	Motor	
DBY02	35 (889)	37 (940)	32 (813)	18-3/4 (476)	1	1	55
DBY03	35 (889)	37 (940)	32 (813)	18-3/4 (476)	1	1	60
DBY04	41 (1041)	43 (1092)	38 (965)	24-3/4 (629)	2	1	70
DBY06	53 (1346)	55 (1397)	50 (1270)	35-3/4 (908)	2	1	82
DBY08	53 (1346)	55 (1397)	50 (1270)	35-3/4 (908)	2	1	95
DBY10	75 (1905)	77 (1956)	72 (1829)	49-3/4 (1264)	4	2	135
DBY12	75 (1905)	77 (1956)	72 (1829)	49-3/4 (1264)	4	2	154

- NOTES: 1. RH shown, LH opposite.  
 2. All dimensions are +/- .25 (6). Drawing not to scale.  
 3. Product specifications are subject to change without notice.  
 4. Control box size and position may vary (consult factory).  
 5. Position may vary.  
 6. Service access is located on the front of the control box.  
 7. Knockouts on the bottom and side of the control box for incoming power connections.  
 8. Typical size 06 unit shown with 1-Motor and 2-BLWR – Refer to table for variation.  
 9. See Valve Package Supplemental for piping termination.  
 10. Field connection pipes will be shipped loose with valve packages.

Drawing is provided for reference only.  
 Dimensions may vary with options ordered.  
 Consult IEC website for submittal drawings.



### CUH Exploded View – DXY

#### Horizontal Cabinet Heater, Hydronic Heat, Front Supply

ITEM	DESCRIPTION
1	COIL ASSY
2	TOP PNL ASSY
3	SIDE PNL RH ASSY
4	SIDE PNL LH ASSY
5	BOT PNL SW ASSY
6	REAR PNL ASSY
7	FRNT PNL ASSY
8	CNTL PKG
9	TOP WRPR ASSY
10	TOP WRPR SPRT BRKT
11	BOT PAN CALV C**06
12	DISCH BAF ASSY
13	FLTR TA
14	MOT BLO DECK ASSY
15	GROM 0.75 X 0.38

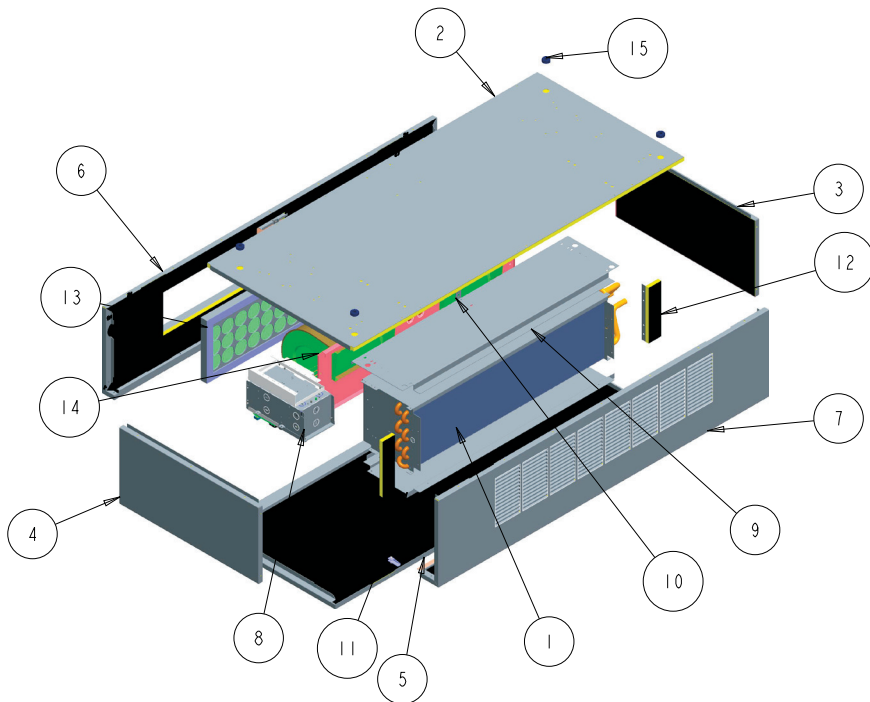

#### Horizontal Cabinet Heater, Electric Heat, Front Supply

ITEM	DESCRIPTION
1	TOP PNL ASSY
2	SIDE PNL RH ASSY
3	SIDE PNL LH ASSY
4	BOT PNL SW ASSY
5	REAR PNL ASSY
6	FRNT PNL ASSY
7	GUARD, RMT SGL EH CONN
8	CNTL PKG
9	TOP WRPR SPRT BRKT
10	HTR ASSY
11	HEATER PLNM ASSY
12	FLTR TA
13	MOT BLO DECK ASSY
14	GROM 0.75 X 0.38

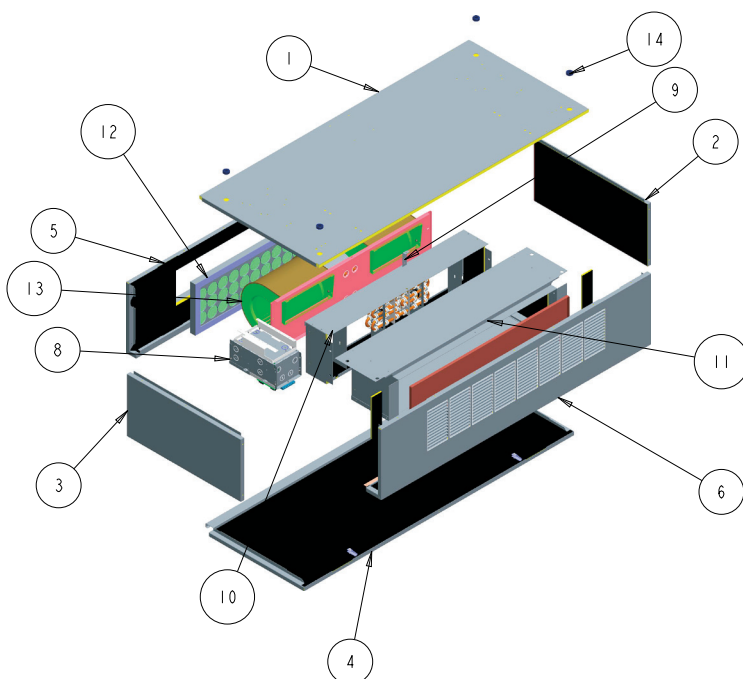

# Cabinet Heater D\*Y Series

## TECHNICAL CATALOG

### Physical Data – DXY

#### DXY – Horizontal Cabinet Heater, Hydronic Heat, Front Supply

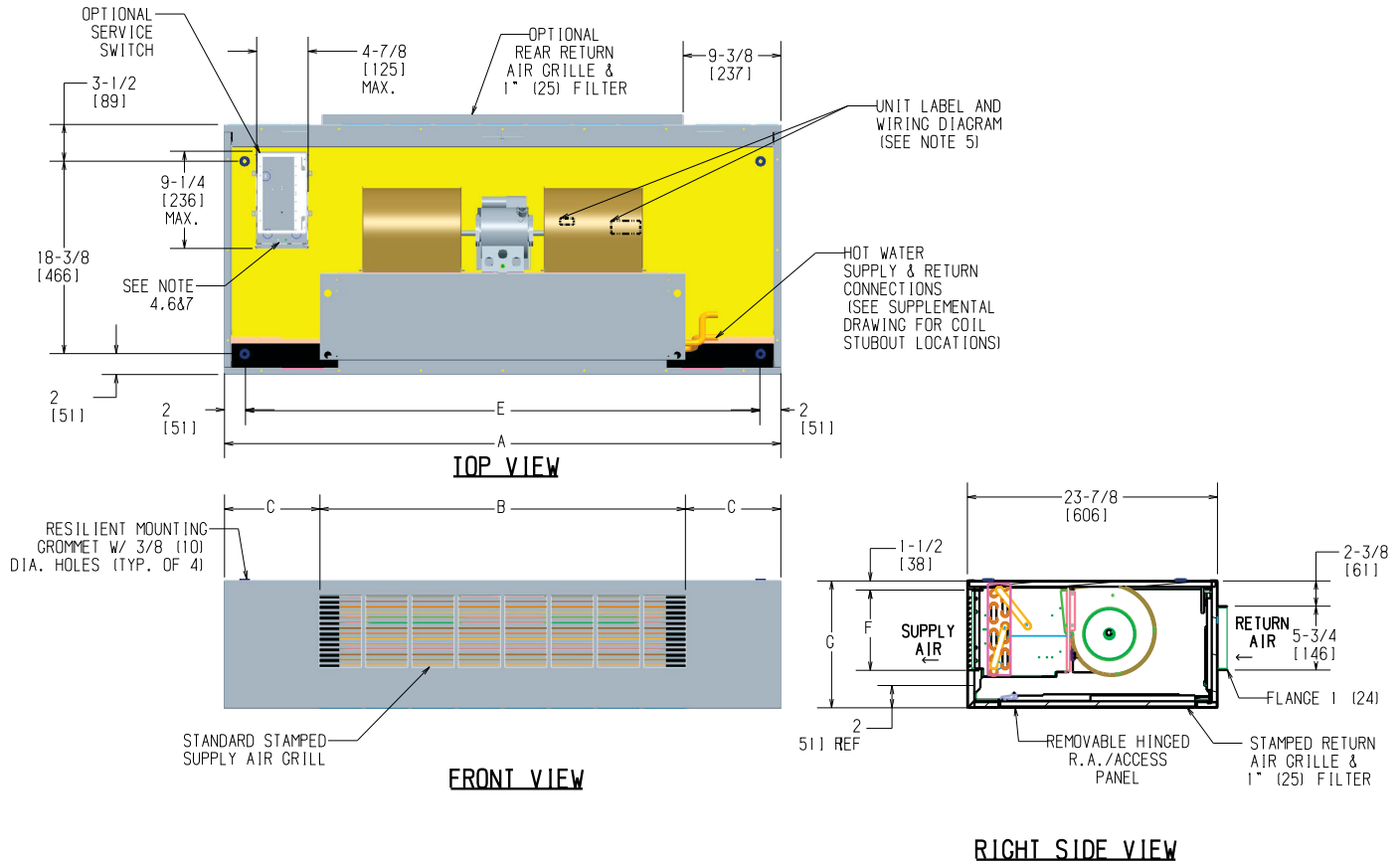

Unit Model	Dimensions - Inches (Millimeters)						Quantity/Unit		Unit Weight*
	A	B	C	E	F	G	Blower	Motor	
DXY02	38 (965)	17-1/8 (435)	10-7/16 (265)	34 (864)	5-3/4 (146)	11 (279)	1	1	98
DXY03	42 (1067)	21-1/2 (546)	10-1/4 (260)	38 (965)	5-3/4 (146)	11 (279)	1	1	118
DXY04	48 (1219)	25-7/8 (657)	11-1/16 (281)	44 (1118)	5-3/4 (146)	11 (279)	2	1	126
DXY06	53 (1346)	34-5/8 (879)	9-3/16 (233)	49 (1245)	6-3/4 (171)	12 (305)	2	1	168
DXY08	60 (1524)	39 (991)	10-1/2 (267)	56 (1422)	6-3/4 (171)	12 (305)	2	1	176
DXY10	74 (1880)	52-1/8 (1324)	10-15/16 (262)	70 (1778)	6-3/4 (171)	12 (305)	4	2	215
DXY12	82 (2083)	60-7/8 (1546)	10-9/16 (268)	78 (1981)	6-3/4 (171)	12 (305)	4	2	245

- NOTES:**
1. RH shown, LH opposite.
  2. All dimensions are +/- .25 (6). Drawing not to scale.
  3. Product specifications are subject to change without notice.
  4. Control box size and position may vary (consult factory).
  5. Position may vary.
  6. Service access is located on the front of the control box.
  7. Knockouts on the bottom and side of the control box for incoming power connections.
  8. Typical size 06 unit shown with 1-Motor and 2-BLWR – Refer to table for variation.
  9. See Valve Package Supplemental for piping termination.
  10. Field connection pipes will be shipped loose with valve packages.

Drawing is provided for reference only.  
 Dimensions may vary with options ordered.  
 Consult IEC website for submittal drawings.

### Physical Data – DXY, Cont'd.

#### DXY – Horizontal Cabinet Heater, Electric Heat, Front Supply

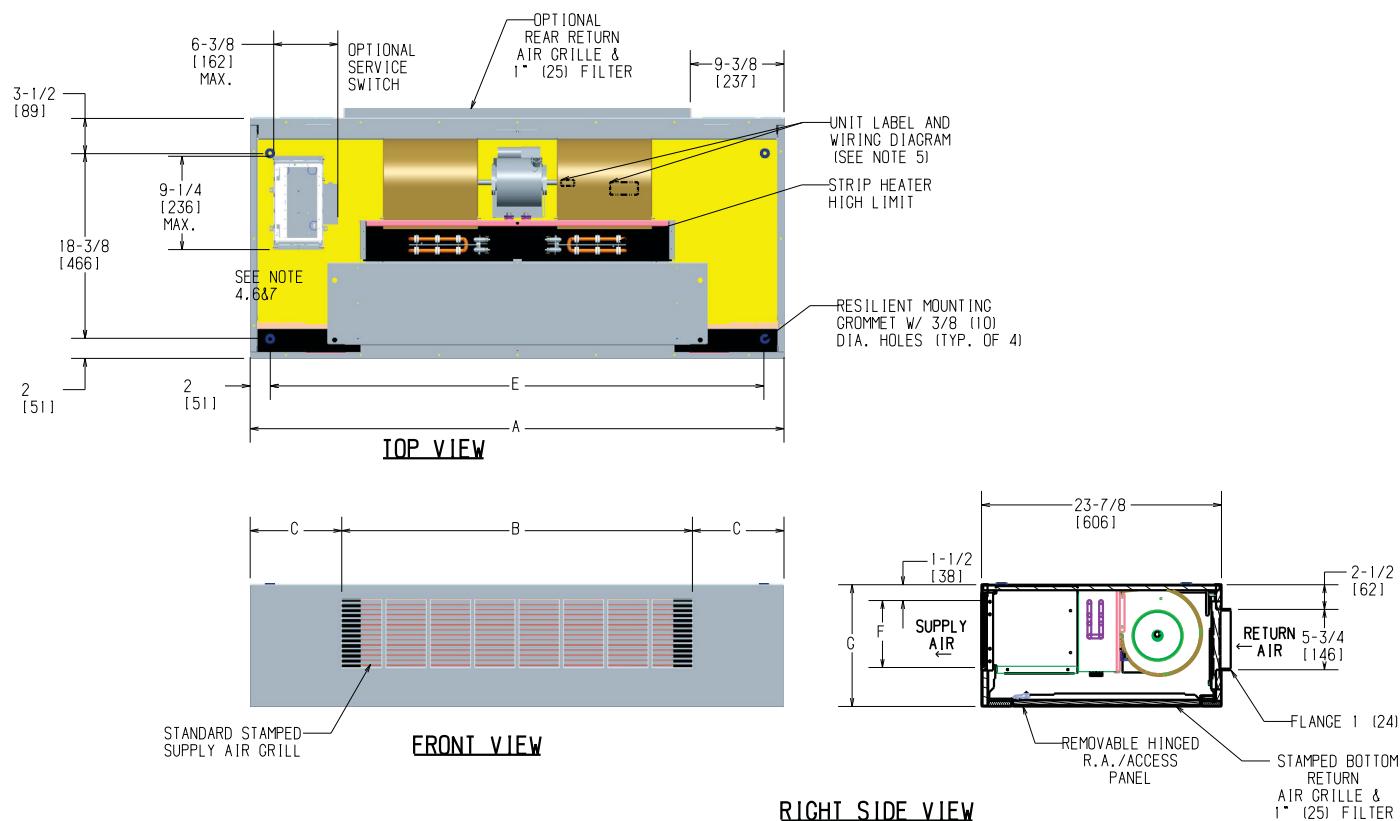

Unit Model	Dimensions - Inches (Millimeters)						Quantity/Unit		Unit Weight*
	A	B	C	E	F	G	Blower	Motor	
DXY02	38 (965)	17-1/8 (435)	10-7/16 (265)	34 (864)	5-3/4 (146)	11 (279)	1	1	98
DXY03	42 (1067)	21-1/2 (546)	10-1/4 (260)	38 (965)	5-3/4 (146)	11 (279)	1	1	118
DXY04	48 (1219)	25-7/8 (657)	11-1/16 (281)	44 (1118)	5-3/4 (146)	11 (279)	2	1	126
DXY06	53 (1346)	34-5/8 (879)	9-3/16 (233)	49 (1245)	6-3/4 (171)	12 (305)	2	1	168
DXY08	60 (1524)	39 (991)	10-1/2 (267)	56 (1422)	6-3/4 (171)	12 (305)	2	1	176
DXY10	74 (1880)	52-1/8 (1324)	10-15/16 (262)	70 (1778)	6-3/4 (171)	12 (305)	4	2	215
DXY12	82 (2083)	60-7/8 (1546)	10-9/16 (268)	78 (1981)	6-3/4 (171)	12 (305)	4	2	245

- NOTES:**
1. RH shown, LH opposite.
  2. All dimensions are +/- .25 (6). Drawing not to scale.
  3. Product specifications are subject to change without notice.
  4. Control box size and position may vary (consult factory).
  5. Position may vary.
  6. Service access is located on the front of the control box.
  7. Knockouts on the bottom and side of the control box for incoming power connections.
  8. Typical size 06 unit shown with 1-Motor and 2-BLVR - Refer to table for variation.
  9. See Valve Package Supplemental for piping termination.
  10. Field connection pipes will be shipped loose with valve packages.

Drawing is provided for reference only. Dimensions may vary with options ordered. Consult IEC website for submittal drawings.

# Cabinet Heater D\*Y Series

## TECHNICAL CATALOG

### Physical Data – DXY, Cont'd.

#### DXY – Horizontal Cabinet Heater, Hydronic Heat, Bottom Supply

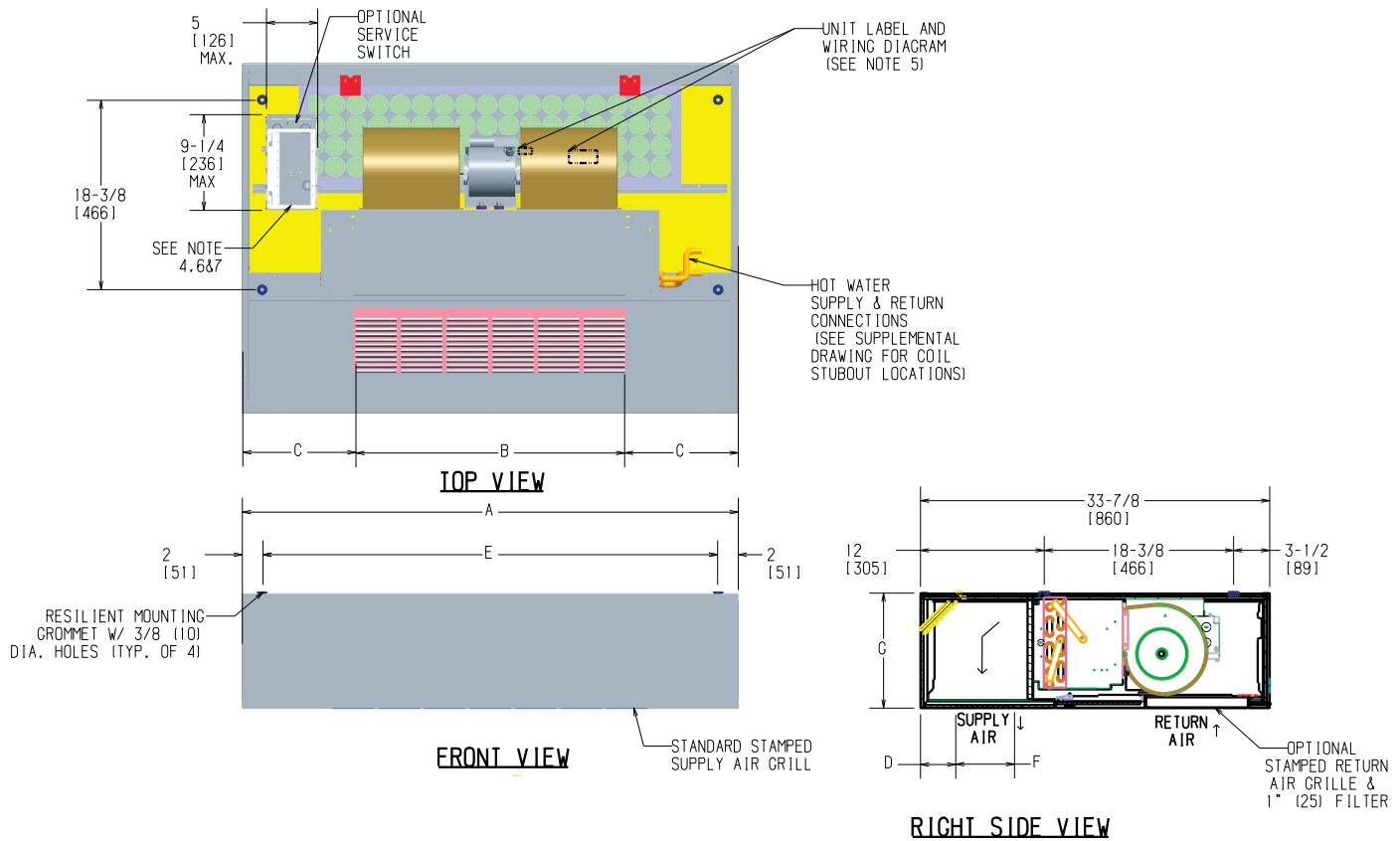

Unit Model	Dimensions - Inches (Millimeters)							Quantity/Unit		Unit Weight*
	A	B	C	D	E	F	G	Blower	Motor	
DXY02	38 (965)	17-1/8 (435)	10-7/16 (265)	3-1/4 (83)	34 (864)	5-3/4 (146)	11 (279)	1	1	98
DXY03	42 (1067)	21-1/2 (546)	10-1/4 (260)	3-1/4 (83)	38 (965)	5-3/4 (146)	11 (279)	1	1	118
DXY04	48 (1219)	25-7/8 (657)	11-1/16 (281)	3-1/2 (89)	44 (1118)	5-3/4 (146)	11 (279)	2	1	126
DXY06	53 (1346)	34-5/8 (879)	9-3/16 (233)	2-1/4 (57)	49 (1245)	6-3/4 (171)	12 (305)	2	1	168
DXY08	60 (1524)	39 (991)	10-1/2 (267)	2-1/4 (57)	56 (1422)	6-3/4 (171)	12 (305)	2	1	176
DXY10	74 (1880)	52-1/8 (1324)	10-15/16 (262)	2-1/2 (64)	70 (1778)	6-3/4 (171)	12 (305)	4	2	215
DXY12	82 (2083)	60-7/8 (1546)	10-9/16 (268)	2-1/2 (64)	78 (1981)	6-3/4 (171)	12 (305)	4	2	245

- NOTES:
1. RH shown, LH opposite.
  2. All dimensions are +/- .25 (6). Drawing not to scale.
  3. Product specifications are subject to change without notice.
  4. Control box size and position may vary (consult factory).
  5. Position may vary.
  6. Service access is located on the front of the control box.
  7. Knockouts on the bottom and side of the control box for incoming power connections.
  8. Typical size 06 unit shown with 1-Motor and 2-BLWR - Refer to table for variation.
  9. See Valve Package Supplemental for piping termination.
  10. Field connection pipes will be shipped loose with valve packages.

Drawing is provided for reference only.  
Dimensions may vary with options ordered.  
Consult IEC website for submittal drawings.

### Physical Data – DXY, Cont'd.

#### DXY – Horizontal Cabinet Heater, Electric Heat, Bottom Supply

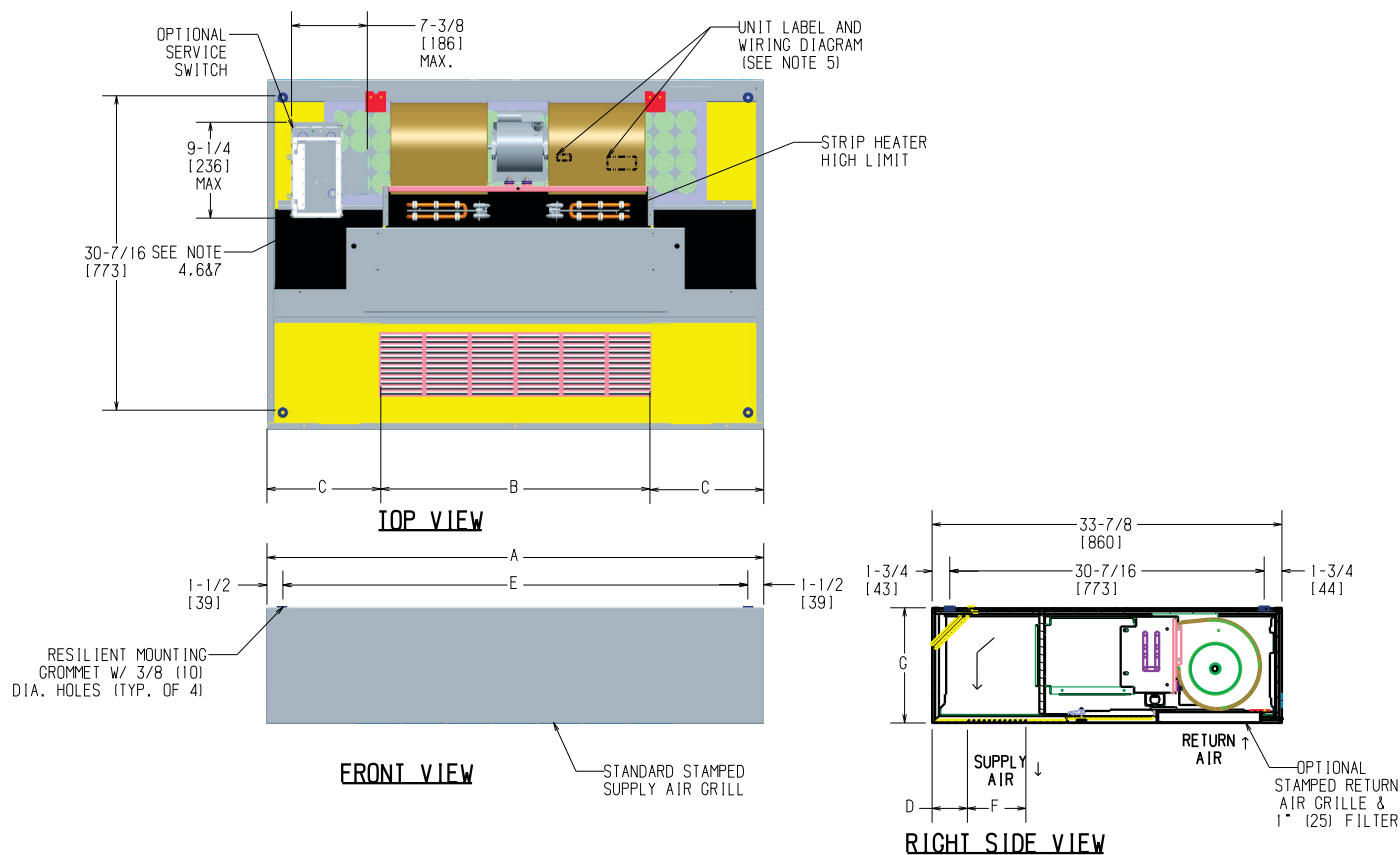

Unit Model	Dimensions - Inches (Millimeters)							Quantity/Unit		Unit Weight*
	A	B	C	D	E	F	G	Blower	Motor	
DXY02	38 (965)	17-1/8 (435)	10-7/16 (265)	3-1/4 (83)	34 (864)	5-3/4 (146)	11 (279)	1	1	98
DXY03	42 (1067)	21-1/2 (546)	10-1/4 (260)	3-1/4 (83)	38 (965)	5-3/4 (146)	11 (279)	1	1	118
DXY04	48 (1219)	25-7/8 (657)	11-1/16 (281)	3-1/2 (89)	44 (1118)	5-3/4 (146)	11 (279)	2	1	126
DXY06	53 (1346)	34-5/8 (879)	9-3/16 (233)	2-1/4 (57)	49 (1245)	6-3/4 (171)	12 (305)	2	1	168
DXY08	60 (1524)	39 (991)	10-1/2 (267)	2-1/4 (57)	56 (1422)	6-3/4 (171)	12 (305)	2	1	176
DXY10	74 (1880)	52-1/8 (1324)	10-15/16 (262)	2-1/2 (64)	70 (1778)	6-3/4 (171)	12 (305)	4	2	215
DXY12	82 (2083)	60-7/8 (1546)	10-9/16 (268)	2-1/2 (64)	78 (1981)	6-3/4 (171)	12 (305)	4	2	245

- NOTES:**
1. RH shown, LH opposite.
  2. All dimensions are +/- .25 (6). Drawing not to scale.
  3. Product specifications are subject to change without notice.
  4. Control box size and position may vary (consult factory).
  5. Position may vary.
  6. Service access is located on the front of the control box.
  7. Knockouts on the bottom and side of the control box for incoming power connections.
  8. Typical size 06 unit shown with 1-Motor and 2-BLWR - Refer to table for variation.
  9. See Valve Package Supplemental for piping termination.
  10. Field connection pipes will be shipped loose with valve packages.

Drawing is provided for reference only. Dimensions may vary with options ordered. Consult IEC website for submittal drawings.

### Physical Data, Cont'd.

#### DXY/DBY Valve Package and Coil Termination Supplement

2 PIPE HEATING

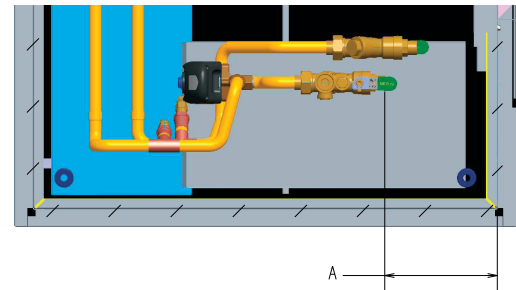
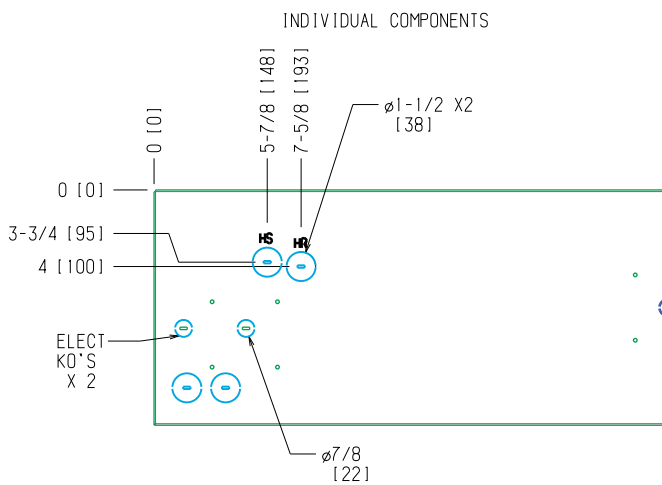
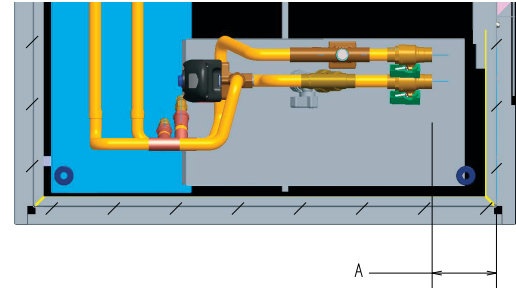
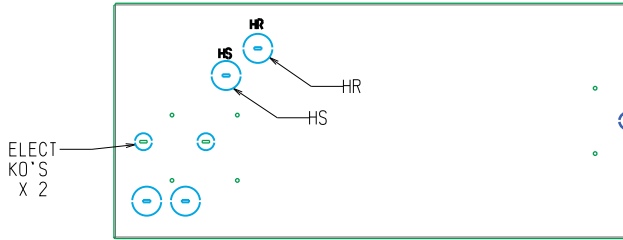

COMBO VALVE  
**PARTIAL REAR VIEWS OF DB/DX UNITS**

LH SIDE SHOWN  
RH OPPOSITE

Dimensions - Inches (Millimeters)		
NO COMBO VALVES	A	
	SUPPLY	RET
3 WAY TACO/ERIE HEAT	3-3/16 (81)	3-3/16 (81)
3 WAY MODULATING HEAT	3-1/8 (79)	1-5/8 (41)
2 WAY TACO/ERIE HEAT	3-1/4 (83)	3-1/4 (83)
2 WAY MODULATING HEAT	3-3/16 (81)	1-1/4 (32)

Dimensions - Inches (Millimeters)		
COMBO VALVES	A	
	SUPPLY	RET
3 WAY TACO/ERIE HEAT	1-1/2 (38)	3-3/16 (81)
3 WAY MODULATING HEAT	1-9/16 (40)	1-9/16 (40)
2 WAY TACO/ERIE HEAT	13/16 (21)	5-1/8 (130)
2 WAY MODULATING HEAT	6 (152)	3-5/8 (92)

NOTES: 1. All dimension are ± 1/4" (6.3 mm).

Drawing is provided for reference only.  
Dimensions may vary with options ordered.  
Consult IEC website for submittal drawings.

**Airflow Arrangements**

**DXY – Horizontal Cabinet Heater**

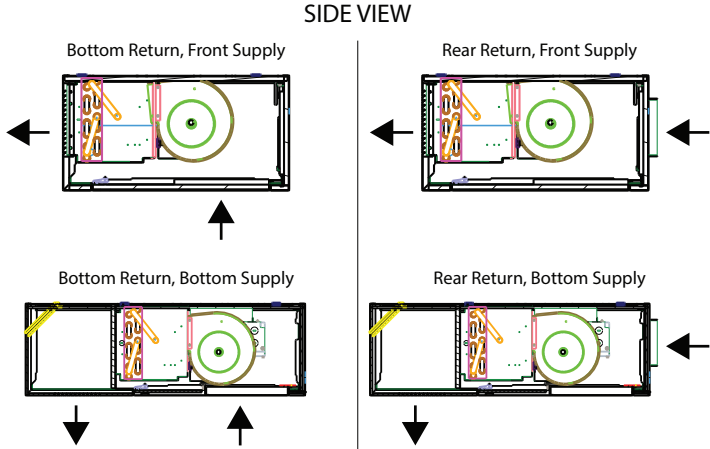

**DBY – Horizontal Telescoping Hideaway Cabinet Heater**

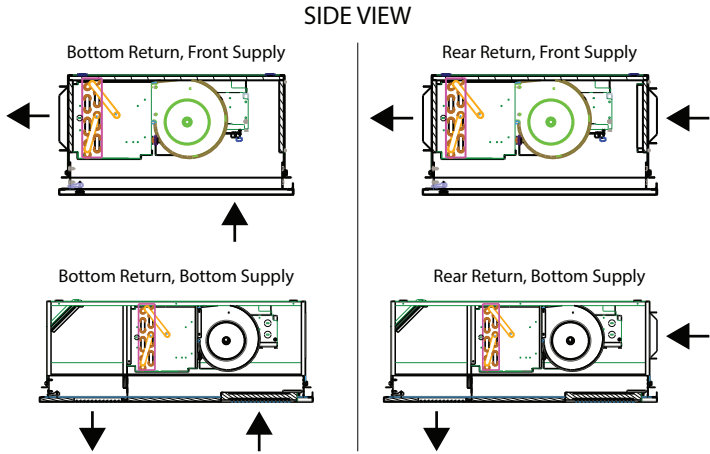

# Cabinet Heater D\*Y Series

## TECHNICAL CATALOG

### Standard Features and Options

Ceiling units are constructed with 18 gauge galvanized steel.

Features And Options	Standard	Factory Installed Option	Field Installed Option	Factory Special Quote
<b>Air Flow Arrangement</b>				
Front Supply/Rear Return		X		
Front Supply/ Bottom Return	X			
Bottom Supply/Bottom Return		X		
Bottom Supply/Rear Return		X		
<b>Coils</b>				
1 Row 2-Pipe		X		
2 Rows 2-Pipe	X			
3 Rows 2-Pipe		X		
4 Rows 2-Pipe		X		
Manual Air Vent	X			
0.025" Tube Thickness				X
Automatic Air Vent		X		
Steam Coils				X
Coil Test Pressure 350	X			
Coil Test Pressure 400, 450		X		
<b>Connection</b>				
Right or Left (Same End)	X			
<b>Fin Material</b>				
Aluminum with Galvanized End Sheets	X			
Nichrome Wire Strip Electric Heater (Total Electric Heat)	X			
<b>Indoor Air Quality</b>				
1" Throwaway non-woven synthetic filter	X			
1" Permanent		X		
1" Pleated MERV 8		X		
Bipolar Ionizer		X		
<b>Insulation</b>				
1/2" Standard Fiberglass	X			
1/2" Premium IAQ Fiberglass		X		X
1/2" Foil Face		X		
1/4" Closed Cell		X		
<b>Motor Type</b>				
PSC Motors with Quick Connect Plug	X			
ECM Motors with Quick Connect		X		
<b>Motor Voltage</b>				
120/1/60 3-Speed	X			
208/230/277/1/60 3-Speed (Optional Voltage)		X		

table continued on next page



## Standard Features and Options, Cont'd.

Features And Options	Standard	Factory Installed Option	Field Installed Option	Factory Special Quote
<b>Supply/Return Air Grilles</b>				
Louvered Stamped Supply Grille (DXY)	X			
Double Deflection, Aluminum Finish Supply Grille		DXY	DBY	
Double Deflection, Integral Supply Grille - painted		DXY		
Stamped Return Grille	X			
Hinged Bar-Type, Aluminum-finish Return Grille with Throwaway Filter - F.O.			DBY	
<b>Paint Options</b>				
Arctic White	X			
Polar White, Flat Black, Ermine Gray, Champagne Beige, Toffee Brown		X		
Special Color				X
<b>Controls</b>				
Service Switch with Lockout Tabs		X		
Single Point Power Connection		X		
Incoming Power Fusing (Total Electric Heat)	X			
24V Controls		X		
Live Voltage Controls		X		
3-Speed Switch		X	X	
Thermostats			X	
Custom Control (DDC)		X		X
<b>Valve Package Options* (* Valve packages are assembled at the factory but field installed.)</b>				
Union Connections at the Coil			X	
24" Braided Hoses			X	
Ball Valves			X	
2-Way/3-Way 25 psi Control Valve			X	
2-Way/3-Way 150 psi, Normally Closed, Control Valve			X	
2-Way/3-Way 150 psi, Normally Open, Control Valve			X	
2-Way/3-Way 35 psi Floating Control Valve			X	
2-Way/3-Way 35 psi Proportional Control Valve			X	
Combination Supply/Return Valves			X	
Fixed Flow Control 1.0-8.0 GMP			X	
Y-Strainer/Y-Strainer with Blowdown			X	
P-T Ports			X	
Circuit Setter			X	
Balance Valve (Return Line)			X	
Balance Valve (3-Way Bypass)			X	

### Standard Features and Options, Cont'd.

#### Nominal Filter Sizes

All cabinet model units (except CH) have non-woven synthetic throwaway filters furnished as standard equipment. Cleanable and pleated filters are optional.

Unit Size	DBY	DBY	DXY	DXY	DXY
	Bottom Return Stamped	Rear Return	Bottom Return Stamped	Rear Return Stamped	Rear Return Ducted
02	10" x 28" (254 x 711)	7" x 21" (178 x 533)	10" x 23-1/2" (254 x 597)	8-3/4" x 23-1/2" (222 x 597)	8-3/4" x 23-1/2" (222 x 597)
03	10" x 28" (254 x 711)	7" x 21" (178 x 533)	10" x 28" (254 x 711)	8-3/4" x 26-1/2" (222 x 673)	8-3/4" x 26-1/2" (222 x 673)
04	10" x 33" (254 x 838)	7" x 27" (178 x 686)	10" x 32-1/2" (254 x 826)	8-3/4" x 32-1/2" (222 x 826)	8-3/4" x 32-1/2" (222 x 826)
06	10" x 45" (254 x 1143)	7" x 38" (178 x 965)	10" x 37" (254 x 940)	8-3/4" x 37" (222 x 940)	8-3/4" x 37" (222 x 940)
08	10" x 45" (254 x 1371)	7" x 38" (178 x 965)	10" x 41" (254 x 1041)	8-3/4" x 41" (222 x 1041)	8-3/4" x 41" (222 x 1041)
10	10" x 62" (254 x 1575)	7" x 52" (178 x 1321)	10" x 54-1/2" (254 x 1384)	8-3/4" x 54-1/2" (222 x 1384)	8-3/4" x 54-1/2" (222 x 1384)
12	10" x 62" (254 x 1575)	7" x 52" (178 x 1321)	10" x 63" (254 x 1600)	8-3/4" x 63" (222 x 1600)	8-3/4" x 63" (222 x 1600)

NOTES: 1. Filter sizes for the models are recommended filter sizes only. No filter is factory provided with these models.  
 2. Sizes shown are nominal ordering sizes.

#### Filter Static Resistance (in w.c.)

Unit Data			Filter Pressure Drop		
Model	Unit Size	Nominal CFM	1" Throwaway	1" Permanent	1" Merv 8
DBY	02	200	0.046	0.078	0.13
	03	300	0.066	0.145	0.18
	04	400	0.068	0.154	0.18
	06	600	0.072	0.171	0.19
	08	800	0.088	0.274	0.30
	10	1000	0.083	0.236	0.25
	12	1200	0.093	0.321	0.37
DXY	02	200	0.037	0.054	0.11
	03	300	0.046	0.076	0.13
	04	400	0.052	0.094	0.14
	06	600	0.066	0.144	0.17
	08	800	0.076	0.194	0.21
	10	1000	0.073	0.175	0.20
	12	1200	0.075	0.186	0.21

**Standard Features and Options, Cont'd.**

**Bipolar Ionizer Specifications**

<b>SPECIFICATIONS:</b>	
Airflow Capacity: .....	2,400 CFM
Pressure Drop: .....	Less than 0.01 In. WG
Housing Material: .....	ABS
Weight: .....	0.2 lbs.
Maximum Operating Temperature: .....	200° F (93°C)
<b>Electrical:</b>	
Voltage: .....	24V AC (602)
Power Consumptions: .....	Less than 1 watt
Frequency: .....	50/60 hertz
Over Current Protection: ..	500mA Glass Cartridge Fuse
Lead Wires .....	50"(L)
<b>Ionization Output:</b>	
Mode of Operation: .....	Needlepoint Type
Needle Configuration: .....	Brush Type
<b>DIMENSIONS:</b> See Figure 1	
<b>APPROVALS:</b> Intertek/ETL Standard UL 867	

Figure 1. Dimensions not to scale.

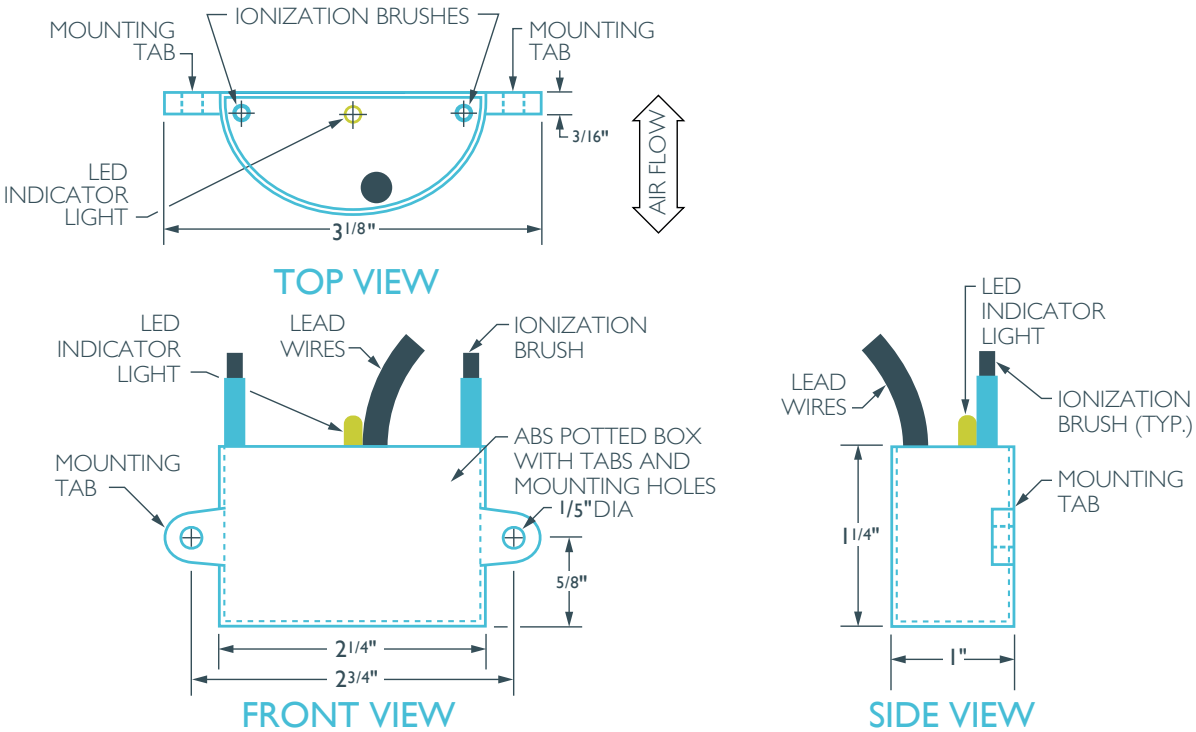

## Standard Features and Options, Cont'd.

### Control Packages

#### Controls

As detailed in the table below and on page 55, we offer control packages that fit most customer needs. Additional controls and devices are available to meet even the most demanding operating logic.

#### Low Voltage Control (24V)

The 85 Control Board (see page 58) offers simplified install and service with its plug-in connections and QR code for quick wiring diagram reference. It also offers LED diagnostics and built-in design flexibility for added features such as staged cooling or BAS signal input. The 85 Control board is available with most control schemes.

#### 85 Control Board Standard Features

- Simplified plug connections
- PSC or ECM control
- LED diagnostics (See IOM-100 for detailed LED function and outcome)
- QR code to wire diagram for ease of troubleshooting
- Conduit compatible for remote mounted control boxes
- Compatibility with all actuator types
- Removable thermostat connector

#### 85 Control Board Options

- ECM fan speed adjustment
- Staged Cooling: compatible with IEC Venture Wi-Fi Thermostat (E055 - 1520330)
- BAS signal input to interrupt fan and actuators
- Fusing and service switch with electric heat
- Changeover or aquastat sensor
- Condensate switch LED indication
- Damper control

#### Service Switches

We offer concealed service switches for use by maintenance and service personnel to shut off the power while working on the unit.

#### Fusing

We offer incoming power fusing for all units as well as blower motor and control sub-fusing (single power source wiring).

#### Other Control Options

- Unit mounted 3-speed switch (thermostat by others)
- Low voltage remote shutdown relays (Special Quote)
- Fan and valve cycle applications (Special Quote)
- Thermostats available with large letter print for handicap applications (Special Quote)

### Standard Features and Options, Cont'd.

#### Controls Packages, Cont'd.

#### 85 Control Board

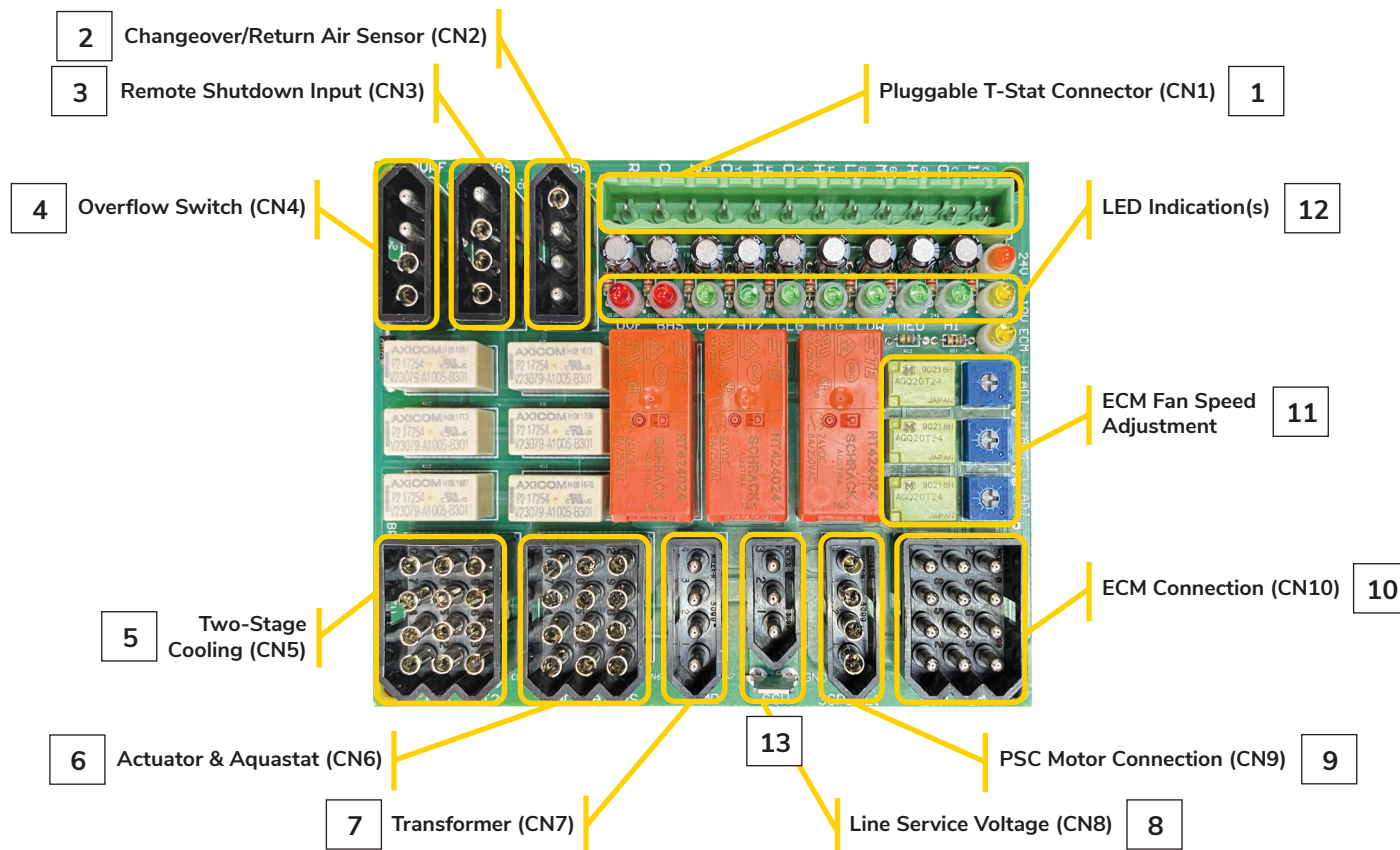

1	CN1 – 24V Customer Input (Thermostat)
2	CN2 – Changeover/Return Air Sensor
3	CN3 – Remote Shutdown Input
4	CN4 – Condensate Overflow Switch
5	CN5 –Two Stage Cooling
6	CN6 – Actuator & Aquastat
7	CN7 – Transformer
8	CN8 – Line Service Voltage
9	CN9 – PSC Motor Connection
10	CN10 – ECM Connection
11	ECM Fan Speed Adjustment
12	LED Diagnostics
13	Ground Connection

### Standard Features and Options, Cont'd.

#### Thermostat Control Package Applications

Unit Type	Control Option	System Type	Changeover Type	W	P	N	F	G	A	B	C
-	Manual Fan	Manual <sup>1</sup>	None	-	-	-	-	-	-	-	-
2-Pipe	Valve Cycle*	Heat Only	None	•	•	•	•	•	•	•	•
Electric Heat		Total Electric Heat	None	•	•	•	•	•	•	•	•

NOTE: 1. Fan switch only; no thermostat

#### Thermostat Features

All listed controls include fan switching.	Control Type <sup>1</sup>						
	W	P	N	F	G	A	B
24V, 115V, 208V, 240V, 277V	24V only	24V only	24V only	24V only	24V only	•	•
Wi-Fi Enabled	•	-	-	-	-	-	-
Mobile and Web App for Remote Control	•	-	-	-	-	-	-
Staged Cooling	•	-	-	-	-	-	-
Programmable	•	•	-	•	-	-	-
Remote Wall Mounted	•	•	•	•	•	•	•
Manual Fan Switch Operation	•	•	•	•	•	•	•
Auto Fan Speed Control	•	•	•	•	•	-	-
Continuous 3-Speed Fan	•	•	•	•	•	•	•
Cycling Fan	•	•	•	•	•	•	•
O.A Damper Signal	•	•	•	•	•	-	-
Remote Temperature Sensor	Opt	Opt	Opt	Opt	Opt	•	•
Digital Display & Buttons	•	•	•	•	•	-	-
Local Temperature Set-Back	•	•	•	•	•	-	-
Water Temperature Purge Cycle	•	•	•	•	•	-	-
Proportional Control Valves	-	-	-	•	•	-	-
Floating Control Valves	-	-	-	•	•	-	-
Pipe Sensor	•	•	•	•	•	-	-

NOTES: 1. Control packages with valve cycle are continuous fan operation only.  
 2. All wall-mounted control packages are shipped loose for field installation (Boxes, tile rings, plaster rings, etc. are not provided.).  
 3. Aquastats are included in control packages, as required.

LEGEND: A • Basic Electronic Wall Series, 155, Vertical  
 B • Basic Electronic Wall Series, 155, Horizontal  
 P • Basic 24 V Digital, 7-Day Programmable  
 N • Basic 24 V Digital, Non-Programmable  
 F • Premium 24 V Digital, 7-Day Programmable  
 G • Premium 24 V Digital BACnet with Proportional Fan/Valves Option  
 W • Venture 24 V Wi-Fi Programmable

**Standard Features and Options, Cont'd.**



Venture 24V,  
Wi-Fi Programmable



Basic 24V Digital  
7-Day Programmable and  
Non-Programmable Series



Premium 24V Digital  
7-Day Programmable/BACnet

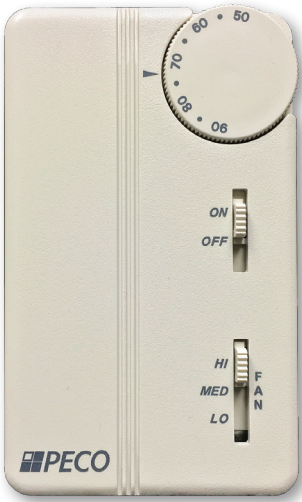

Basic Electronic Wall Series  
155, Vertical and Horizontal



Basic Series, 156,  
Unit Mounted

# Cabinet Heater D\*Y Series

## TECHNICAL CATALOG

### Standard Features and Options, Cont'd.

#### Supply Air Grilles

Unit Size	Nominal CFM	Recommended Grille Size - Inches (Millimeters)
02	200	16" x 6" (406 x 152)
03	300	20" x 6" (508 x 152)
04	400	26" x 6" (660 x 152)
06	600	30" x 6" (762 x 152)
08	800	38" x 6" (965 x 152)
10	1000	52" x 6" (1320 x 152)
12	1200	60" x 6" (1524 x 152)

NOTES: 1. Refer to Submittal Data pages for actual unit supply air opening dimensions.  
2. Field-furnished duct transitions may be required.

#### Return Air Filter Grilles

Unit Size	Nominal CFM	Recommended Grille Size - Inches (Millimeters)
02	200	24" x 10" (610 x 254)
03	300	28" x 10" (711 x 254)
04	400	32" x 10" (813 x 254)
06	600	42" x 10" (1067 x 254)
08	800	42" x 10" (1067 x 254)
10	1000	54" x 10" (1372 x 254)
12	1200	64" x 10" (1626 x 254)

NOTES: 1. Refer to Submittal Data pages for actual unit supply air opening dimensions.  
2. Field-furnished duct transitions may be required.

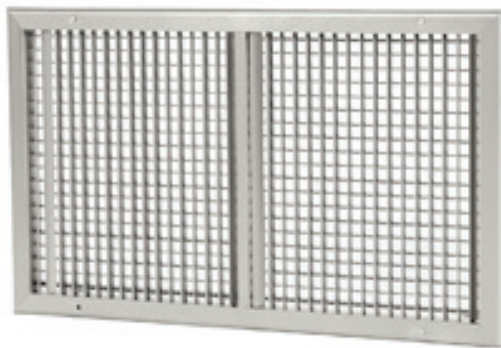

Optional Double Deflection, Aluminum-finish Supply Grille  
(Optional special ship separate for DBY.  
Consult factory for details.)



Optional Hinged, Bar-type, Aluminum-finish  
Return Grille with Throwaway Filter  
(Optional special ship separate for DBY.  
Consult factory for details.)



Optional Double-deflection, Integral Supply Grille  
Painted to Match Color of Unit



## Piping Packages (Typical)

### Two-way Motorized Control Valve

In a two-way motorized control valve package, the motor drives the valve open, and a spring returns the valve to a normally closed position. No water flows with the unit off. The standard supply connection from the coil will accept a swaged copper fitting for field brazing. As an option, this connection may be factory furnished with a union. When a swage is necessary, it becomes part of the valve package. The isolation, or ball, valve in the return piping is shipped loose for field installation.

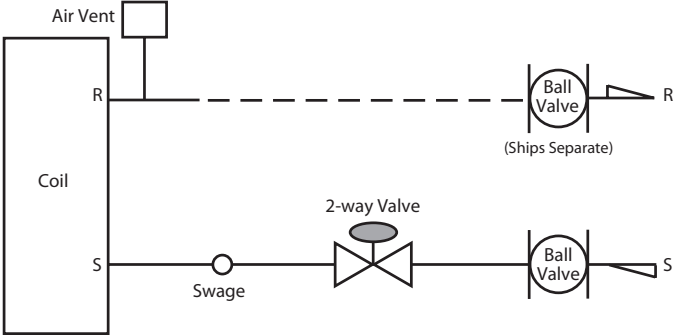

### Three-way Motorized Control Valve

In a three-way motorized control valve package, a diverting valve controls water flow to the coil. When the unit is off, water bypasses the coil and flows directly to the system return. A balancing valve may be specified in the bypass line to permit equal flow balancing.

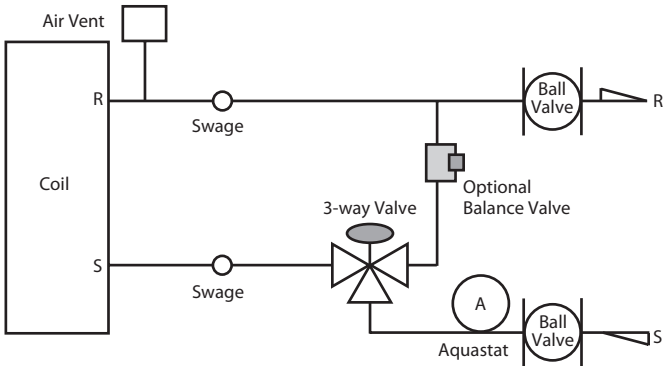

- NOTES:**
1. Please note that project specifications for system pressure, pressure drop limitations and flow rate should be checked prior to selecting specific components or the valve package size
  2. The supply and return piping connections of the factory-provided valve package are either swaged for field brazing (standard) or union fitted (optional) for field connection to the coil.
  3. Consult IEC's Valve Packages and Piping Components manual or your local representative for detailed piping and valve application information. Factory-provided valve packages are assembled, brazed, wired electrically and dry-fit to the coil connections before shipping. Field brazing to the coil completes the installation. Some applications dictate shipping isolation valves loose.

# Cabinet Heater D\*Y Series

## TECHNICAL CATALOG

---

This page intentionally left blank.

This page intentionally left blank.

# Cabinet Heater D\*Y Series

## TECHNICAL CATALOG

---



Contact your local IEC Sales Representative for further details and pricing applicable to this product. Visit our website ([iec-okc.com](http://iec-okc.com)) to find your local IEC Sales Rep.

IEC Part Number: I100-90034497  
CA-011 Revision 0 (12/2021)

©2021 International Environmental Corporation (IEC)



5000 W. I-40 Service Rd.  
Oklahoma City, OK 73128  
P: 405.605.5000  
F: 405.605.5001  
[www.iec-okc.com](http://www.iec-okc.com)