



## **HBD/VBA**



- **Cost Effective Solution**
- **Easy to Install/Service**
- **Variety of Sizes/Applications**

These compact blower coils are ideally suited for a variety of ducted applications that require a nominal CFM range of 600 to 4000 (actual CFM of 300 to 4200) and total static pressures of up to 2.5" w.g. Units can be floor or ceiling mounted, and are available with a variety of IAQ options to meet today's design requirements. IEC's belt drive series with large access panels, removable, double-sloped stainless steel drain pan and high efficiency filtration option is a perfect, cost-effective solution for meeting rooms in hotels, motels, schools, churches, apartment complexes, universities or any application with large common areas.

# Belt Drive Series

## FAN COIL TECHNICAL CATALOG

---

International Environmental Corporation (IEC) works continually to improve its products. As a result, the design and specifications of each product may be changed without notice and may not be as described herein. Please contact IEC for information regarding current design and product specifications. Statements and other information contained herein are not express warranties and do not form the basis of any bargain between the parties but are merely IEC's opinion or commendation of its products. Manufacturer's standard limited warranty applies.

## **Table of Contents**

<b>4-5</b>	Portfolio
<b>6-7</b>	Features and Benefits
<b>8</b>	Unit Model Key
<b>9</b>	Nominal Capacity and Listing
<b>10-17</b>	Cooling Capacity Table
<b>18-21</b>	Heating Capacity Table
<b>22</b>	Component Static Resistance (in w.c.)
<b>23-26</b>	HBD/VBA Fan Curves
<b>27</b>	Motor Data
<b>28</b>	Motor and Drive Selection
<b>29</b>	Sound Power Data – HBD
<b>30</b>	Sound Power Data – VBA
<b>31</b>	Electrical Resistance Heating
<b>32-35</b>	Physical Data
<b>36-37</b>	Physical Data Stub-Out Location
<b>38</b>	Distributed Weight Calculations
<b>39</b>	Filters
<b>40-43</b>	Standard Features and Options
<b>44-45</b>	Options – Mixing Box

### Portfolio

#### Horizontal and Vertical Drive Units – 300 to 4200 CFM (600 to 4000 Nominal)

##### Versatile Units

These compact blower coils are ideally suited for a variety of ducted applications that require a range of 300 to 5000 CFM, capacities between 1.5 tons to 10 tons, and total static pressures of up to 2.5" w.g. These units provide comfort cooling and heating while offering a broad range of application flexibility between the traditional fan coil unit and a central station air handling unit. Several configurations are available to meet the needs of different climates and applications. The HBD/VBA units can be ordered as a:

- 2-pipe system
- 2-pipe system with electric heat
- 2-pipe system with steam heating (consult factory)
- 4-pipe system



**VBA Unit**

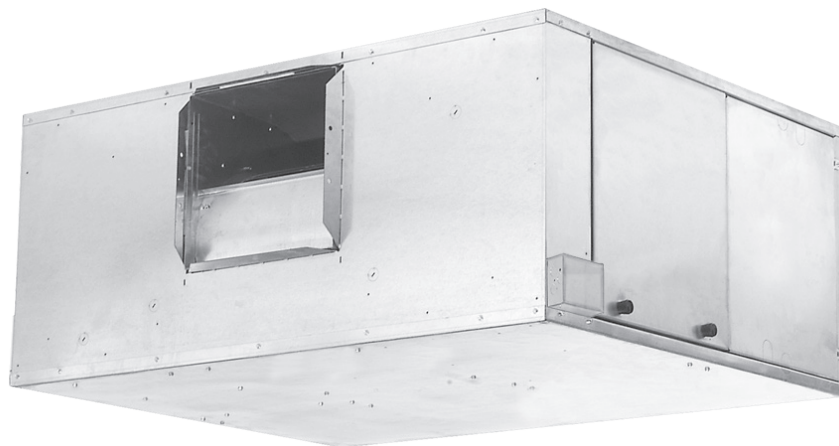

**HBD Unit**

## Portfolio, Cont'd.

### Multitude of Applications

These units can be floor or ceiling mounted, and are available with a variety of options that can meet the design requirements, and provide a low cost solution for a multitude of applications.

- **Standard Horizontal and Vertical Blower Coil Applications**

Where the application calls for cooling capacities or external static pressures that can not be met with standard or high performance direct drive fan coil units use an IEC standard horizontal or vertical blower coil.

- **Outside Air Applications**

With the availability of larger capacities, a variety of optional coils, mixing boxes, and the capability of delivering air through long duct runs, the belt drive units are ideal for handling outside air. When used as outside air units, the heating coil should be in the pre-heat location (consult factory).

- **Large Public Areas**

These units are ideal for applications with a large common area such as restaurants, airports, sports arenas, stadiums, private boxes, gymnasiums, exercise areas, locker rooms, atriums and foyers, auditoriums, shopping malls, equipment or mechanical rooms, and casinos, to name a few.

### Installation Considerations

The HBD/VBA units are typically either suspended above the ceiling or installed in a closet or mechanical room. Attention should be paid to having enough clearance around the units for service and maintenance.

Horizontal units are generally suspended above the ceiling using hanger rods that go through the corner knock-outs provided in the units. External vibration isolation and flex connections for ducts are recommended.

Vertical units are typically installed on a pad. Ensure that you have adequate pad height for proper trapping of the condensate drain.

### Acoustical Considerations

With sound becoming more of a concern to design engineers, building owners, and occupants, proper consideration should be given to the selection and placement of these units.

Whenever possible, avoid placing these units above an occupied space. To further reduce the sound level, additional measures such as: using flexible duct connectors; lining the main supply and return ducts with acoustical absorption material; locating the return air grilles as far away from the unit as possible; and using 3-phase motors.

Running a unit at lower speeds with a high capacity coil, or running an oversized unit at less than nominal CFM may provide acoustical benefits.

### Operating Limitations

The fan curves outline the airflow and static pressure range where it is acceptable to run these units. Running the HBD/VBA units outside this range could lead to drastically reduced bearing life and premature wheel failure. In cooling applications, this could also result in moisture carry over. In addition, running the fan at its maximum fan speed will increase the power requirements and generate higher sound levels. On units with electric heat, the minimum airflow shown on the fan curve must be maintained to prevent excessive discharge temperature and electric heat safety trips.

For leaving discharge air temperatures greater than 130°F (54.4°C), contact the factory.

### Features and Benefits

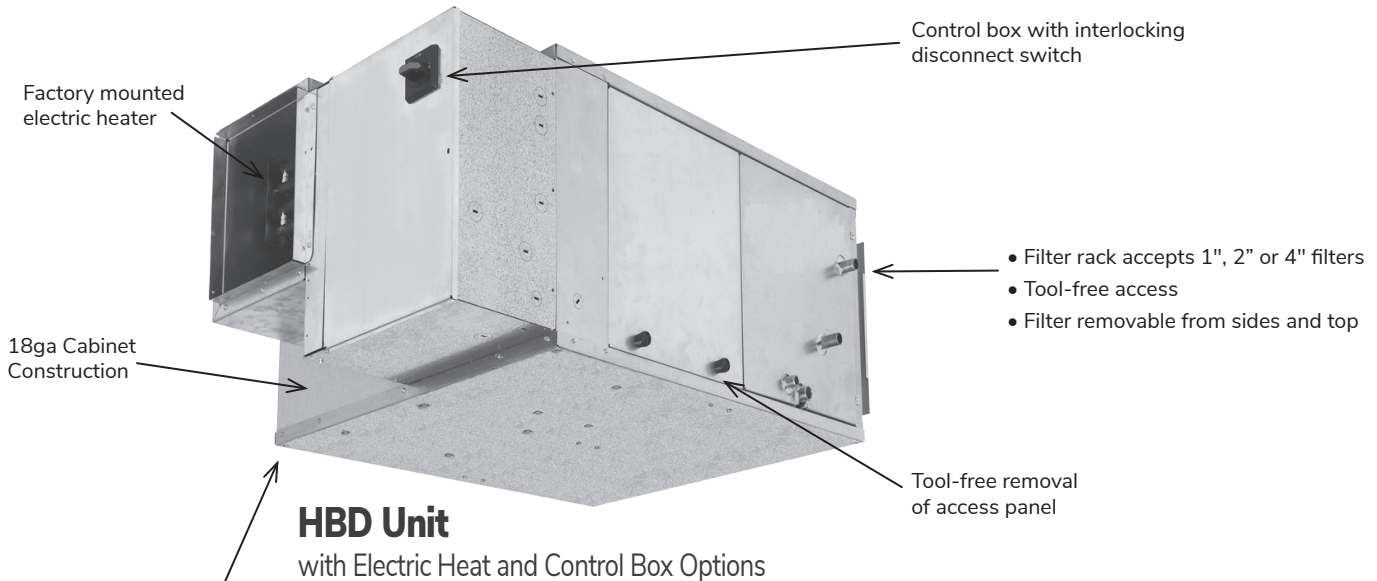

Optional double wall construction

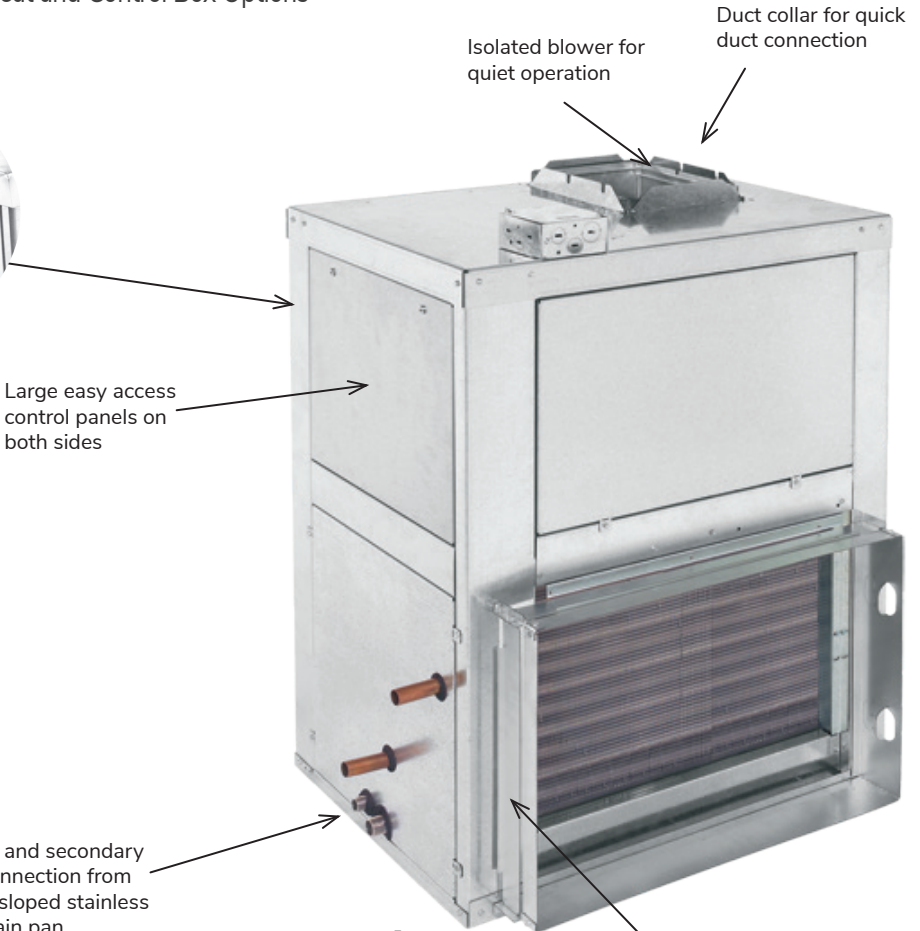

## Features and Benefits, Cont'd.

### Application Fit

- Horizontal and vertical configurations, with 16 different sizes to meet a multitude of room layouts and ventilation needs
- Wide variety of coil options including 100% outside air applications.
- Three forms of isolation: blower from the cabinet by rubber isolators; blower from the duct connections by foam; and resilient mounted motors (up to 2 HP) for quiet and vibration free installations

### Design Flexibility

- Optional 1" double wall construction, perforated or solid lined
- Removable double-sloped stainless steel drain pan for ease of cleaning and for better IAQ performance; all models include primary and secondary drain connections to provide back-up if the main drain is plugged; an optional float switch is available for meeting the requirements of certain building codes
- Wide variety of coil sizes (4, 6, 8-Rows) for a better match to the heating and cooling loads of the space; coils with different materials (copper fins with stainless steel end sheets and bottom coil baffles) and lower pressure drops available to meet the needs of custom applications
- Motors ranging from 1/4 to 3 HP in a variety of voltages, in both single- and 3-phase, with adjustable variable pitch sheave drive kits to meet static pressure requirements; drives pre-set at factory for specific air flow at static pressures as ordered
- A standard filter rack allow different filter types, thickness, and efficiency to address IAQ requirements
- In addition to the standard fiberglass cabinet insulation that meets the requirements of most applications, premium IAQ fiberglass, foil faced, and closed cell insulation are also available as options to meet most IAQ concerns

- Heating provided by a hot water coil, steam coil, or electric heat to meet varying application needs as well as climates
- Mixing boxes available for outside air applications
- Ratings program to speed up project design and selection of equipment

### Ease of Installation

- Units preassembled with factory installed optional electric heater controls reduce the field labor required and provide a single point of responsibility
- 24V control may eliminate the need to run control wiring in conduits
- Corner knock-outs for hanger rods and isolators facilitate quick and easy installation of horizontal units.
- Duct collars for supply and return air provided for ease of installation
- Optional factory installed controls eliminate the need for motor starters

### Ease of Service

- Tool-free and easily accessible filters from multiple sides for ease of maintenance
- Large access panels (tool-free on horizontal units) on both sides for ease of maintenance
- Motors mounted on an adjustable base for ease of belt tightening

### Quality and Safety

- Optional seismic structural upgrade to meet IBC-2009 seismic certification
- Every unit tested and inspected at the factory for trouble-free startup
- Motors have built in thermal overload protection or are fused
- ETL and CETL listed

# Belt Drive Series

## FAN COIL TECHNICAL CATALOG

### Unit Model Key

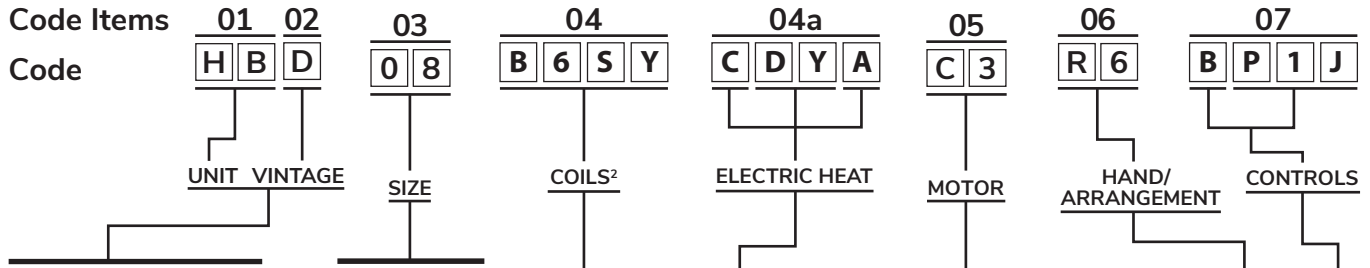

HBD • Horizontal Belt Drive  
VBA • Vertical Belt Drive  
(Available both single and double wall)

(Nominal CFM)  
06 • 600 CFM  
08 • 800 CFM  
10 • 1000 CFM  
12 • 1200 CFM  
16 • 1600 CFM  
20 • 2000 CFM  
30 • 3000 CFM  
40 • 4000 CFM

**Voltage (open drip proof motor)**

C3 • 115-1-60  
D3 • 208-1-60  
E3 • 230-1-60  
F3 • 277-1-60  
N4 • 208-3-60  
P4 • 230-3-60  
G4 • 460-3-60

**Hand<sup>5</sup>**  
R • Right  
L • Left

**Arrangement**

6  
5

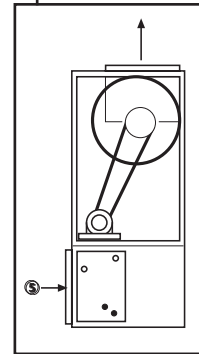
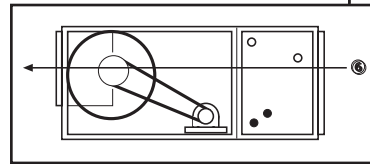

**2-pipe Cooling and Heating or 4-pipe Cooling**

**Hydronic**

B • 4-Row  
K • 6-Row  
L • 8-Row

**4-pipe Heating**

Y • None  
6 • 1-Row  
7 • 2-Row

**Coil Connection**

Y • None  
S • Same End

**Coil Construction**

Y • Std.  
S • SS Wrapper

**Voltage**

C • 120 V, 1-Phase  
D • 208 V, 1-Phase  
E • 240 V, 1-Phase  
F • 277 V, 1-Phase  
N • 208 V, 3-Phase  
P • 240 V, 3-Phase  
G • 480 V, 3-Phase  
Y • None

**kW<sup>4</sup>**

BY • 1.0 kW  
CY • 1.5 kW  
DY • 2.0 kW  
EY • 2.5 kW  
FY • 3.0 kW  
FA • 3.5 kW  
GY • 4.0 kW  
GA • 4.5 kW  
HY • 5.0 kW  
JY • 6.0 kW  
KY • 7.0 kW  
LY • 8.0 kW  
NY • 9.9 kW  
PY • 12.0 kW  
QY • 14.0 kW  
NH • 15.0 kW  
NJ • 16.0 kW  
NL • 18.0 kW  
RY • 19.9 kW  
RH • 25.0 kW  
SY • 30.0 kW  
SH • 35.0 kW  
TY • 39.9 kW  
YY • None

**Stages (single power source)**

A • Single-Stage, 1-Phase  
B • 2-Stage, 1-Phase  
C • Single-Stage, 3-Phase  
D • 2-Stage, 3-Phase  
E • 3-Stage, 3-Phase  
Y • None

**Voltage**

Y • None  
B • 24 V

**Type of Control**

A • Motor  
P • Electric Heat and Motor

**Phase**

1 • 1-Phase  
3 • 3-Phase

**Fusing and Disconnect**

Y • None  
J • 40 amp appropriate fuse  
K • 40 amp disconnect  
H • 41-60 amp disconnect  
L • 61-80 amp disconnect

**NOTES:**

1. For additional details, refer to Price Guide.
2. Total rows allowed is 8.
3. Contact factory for 2-Row heating only application.
4. Note that kW's depend on voltage and unit size. Motor and heater voltage must match. Dual power sources are not available.
5. Standing in front of the unit, hand is determined by looking into the air supply and assigning the hand to match the location of the cooling coil connections.
6. Contact factory for DX applications.



### Nominal Capacity and Listing

#### C-ETL-US Listing

IEC's Belt Drive Series blower coil units are listed by Intertek Testing Services (ITS). ITS's C-ETL-US listing signifies that IEC's blower coil units have been examined by ITS and comply with the minimum requirements of U.S. and Canadian national product safety standard, UL 1995/CSA C22.2 No. 236, and that IEC's manufacturing site



has been audited. ITS's re-examination service includes periodic visits to IEC's factory to ensure continued compliance for all listed products.

#### Seismic Certification

IEC's Belt Drive Series blower coil units with seismic structural upgrade option are independently tested and certified in accordance with IBC-2009.

#### VBA Nominal Capacity Range

Unit Size	Nominal CFM	Cooling Capacity <sup>1</sup> (MBH)		Heating Capacity (MBH)	
		Total	Sensible	Hydronic <sup>2</sup>	Max Electric <sup>3</sup>
06	600	17.9 - 26.8	13.8 - 18.1	13.2 - 38.3	20
08	800	21.9 - 33.8	17.5 - 23.3	15.9 - 47.1	27
10	1000	31.6 - 46.4	23.7 - 31.0	21.8 - 62.8	34
12	1200	35.5 - 53.3	27.2 - 36.1	24.2 - 70.1	41
16	1600	46.5 - 71.4	35.9 - 48.3	31.4 - 94.2	55
20	2000	59.1 - 90.0	45.1 - 60.6	38.9 - 114.7	68
30	3000	87.8 - 135.1	67.6 - 91.1	56.3 - 174.9	102
40	4000	123.8 - 185.8	92.9 - 123.8	78.2 - 237.2	137

**NOTES:**

- Nominal cooling capacity range is based on 80° F (26.7° C) DB and 67° F (19.4° C) WB EAT, 45° F (7.2° C) EWT at 10° F (5.6° C) water temperature rise for 4, 6, and 8 row coils.
- Nominal hydronic heating capacity range is based on 70° F (21.1° C) EAT and 140° F (60° C) to 180° F (82.2° C) EWT at 20° F (11.1° C) water temperature drop for 1 and 2 row heating coils
- Electric heat capacity limit varies by power source. See Electric Heat Selection on page 22.

#### HBD Nominal Capacity Range

Unit Size	Coil Rows	Nominal CFM	Water Pressure Drop (ft.water)	Cooling Capacity <sup>1</sup> (BTUH)		Power Input (Watts)
				Total	Sensible	
06	4	600	1.8	19,900	13,800	85
06	6	600	3.8	25,000	16,000	120
06	8	600	4.8	26,000	16,000	120
08	4	800	2.9	24,900	17,800	160
08	6	800	5.5	31,000	20,100	175
08	8	800	8.4	34,800	21,200	205
10	4	1,000	5.7	33,700	23,200	220
10	6	1,000	10.7	40,500	25,900	240
10	8	1,000	15.9	45,100	27,500	260
12	4	1,200	7.2	38,400	26,800	335
12	6	1,200	14.7	47,600	30,700	350
12	8	1,200	20.5	52,000	31,800	380
16	4	1,600	4.7	49,000	35,300	410
16	6	1,600	10.0	61,500	39,700	420
16	8	1,600	14.2	67,100	41,400	520
20	4	2,000	5.5	62,100	45,000	445
20	6	2,000	11.2	78,000	51,300	465
20	8	2,000	17.0	87,400	55,400	510
22	4	2,200	8.0	65,000	47,200	575
22	6	2,200	15.0	83,800	54,900	600
22	8	2,200	23.0	95,500	59,000	660
30	4	3,000	6.1	98,500	71,100	790
30	6	3,000	10.7	123,900	80,400	860
30	8	3,000	18.4	140,000	88,500	890
40	-	4,000	-	123,800-185,800	92,900-123,800	-

- NOTES:**
- Ratings are based on 80° F (26.7° C) DB and 67° F (19.4° C) WB EAT, 45° F (7.2° C) EWT, 10° F (5.6° C) water temperature rise, high fan speed, motor voltage 115/1/60, and airflow under dry coil conditions.
  - For all application ratings, use IEC's computer selection program, the quick-selection ratings provided in this catalog, or contact your local IEC representative.

# Belt Drive Series

## FAN COIL TECHNICAL CATALOG

### Cooling Capacity Table

Unit Size	CFM	Rows	EAT (°F) DB/WB	EWT (°F)	ΔT (°F)	Total (MBH)	Sensible (MBH)	GPM	WPD (ft. wg.)
06	500	4	80 / 67	45	10	16.9	12.4	3.4	1.6
					12	14.9	11.5	2.5	1.8
			75 / 63	45	10	12.5	10.6	2.5	1.0
					12	11.1	10.0	1.8	0.6
		6	80 / 67	45	10	20.9	14.2	4.1	3.3
					12	19.0	13.4	3.2	3.6
			75 / 63	45	10	15.3	11.9	3.0	2.0
					12	14.0	11.4	2.3	1.3
		8	80 / 67	45	10	22.9	15.1	4.5	5.1
					12	21.1	14.3	3.5	3.3
			75 / 63	45	10	16.7	12.6	3.3	3.1
					12	15.5	12.0	2.6	2.1
	600	4	80 / 67	45	10	19.5	14.5	3.9	1.9
					12	17.4	13.7	2.9	1.2
			75 / 63	45	10	14.6	12.5	2.9	1.2
					12	13.1	11.9	2.2	0.8
		6	80 / 67	45	10	24.5	16.8	4.9	4.2
					12	22.4	16.0	3.7	2.8
			75 / 63	45	10	18.1	14.2	3.6	2.6
					12	16.7	13.6	2.8	1.7
		8	80 / 67	45	10	27.1	18.0	5.4	6.6
					12	25.1	17.2	4.2	4.4
			75 / 63	45	10	20.0	15.1	4.0	4.1
					12	18.6	14.5	3.1	2.7
	700	4	80 / 67	45	10	21.9	16.5	4.3	2.3
					12	19.7	15.7	3.3	1.5
			75 / 63	45	10	16.6	14.3	3.3	1.5
					12	15.1	13.7	2.5	1.0
		6	80 / 67	45	10	27.9	19.3	5.5	5.2
					12	25.6	18.4	4.2	3.4
			75 / 63	45	10	20.8	16.4	4.1	3.3
					12	19.2	15.8	3.2	2.2
		8	80 / 67	45	10	31.2	20.9	6.2	8.3
					12	29.1	20.0	4.8	5.5
			75 / 63	45	10	23.2	17.6	4.6	5.2
					12	21.7	16.9	3.6	3.5

NOTE: Ratings are based on 80° F (26.7° C) DB and 67° F (19.4° C) WB EAT, or 75° F (23.9° C) DB and 63° F (17.2° C) WB; 45° F (7.2° C) EWT, 10° F Ω (5.6° C Ω) or 12° F Ω (6.7° C Ω) water temperature rise.

## Cooling Capacity Table, Cont'd.

Unit Size	CFM	Rows	EAT (°F) DB/WB	EWT (°F)	ΔT (°F)	Total (MBH)	Sensible (MBH)	GPM	WPD (ft. wg.)	
08	700	4	80 / 67	45	10	21.9	16.5	4.3	2.3	
					12	19.7	15.7	3.3	1.5	
			75 / 63	45	10	16.6	14.3	3.3	1.5	
					12	15.1	13.7	2.5	1.0	
		6	80 / 67	45	10	27.9	19.3	5.5	5.2	
					12	25.6	18.4	4.2	3.4	
			75 / 63	45	10	20.8	16.4	4.1	3.3	
					12	19.2	15.8	3.2	2.2	
			8	80 / 67	45	10	31.2	20.9	6.2	8.3
						12	29.1	20.0	4.8	5.5
		75 / 63		45	10	23.2	17.6	4.6	5.2	
					12	21.7	16.9	3.6	3.5	
	800	4	80 / 67	45	10	24.2	18.5	4.8	2.7	
					12	21.9	17.6	3.6	1.7	
			75 / 63	45	10	18.5	16.2	3.7	1.8	
					12	16.9	15.5	2.8	1.2	
			6	80 / 67	45	10	31.1	21.8	6.2	6.1
						12	28.8	20.8	4.8	4.1
		75 / 63		45	10	23.4	18.7	4.6	3.9	
					12	21.8	18.0	3.6	2.6	
		8	80 / 67	45	10	35.2	23.7	7.0	10.0	
					12	33.0	22.7	5.5	6.7	
			75 / 63	45	10	26.3	20.1	5.2	6.3	
					12	24.7	19.3	4.1	4.3	
	900	4	80 / 67	45	10	26.4	20.4	5.2	3.1	
					12	23.9	19.5	4.0	2.0	
			75 / 63	45	10	20.4	17.9	4.0	2.1	
					12	18.6	17.2	3.1	1.4	
			6	80 / 67	45	10	34.2	24.2	6.8	7.1
						12	31.7	23.2	5.2	4.7
		75 / 63		45	10	25.9	20.8	5.1	4.6	
					12	24.2	20.1	4.0	3.1	
		8	80 / 67	45	10	39.2	26.5	7.8	11.8	
					12	36.7	25.4	6.1	8.0	
			75 / 63	45	10	29.4	22.5	5.8	7.5	
					12	27.6	21.7	4.6	5.1	

**NOTE:** Ratings are based on 80° F (26.7° C) DB and 67° F (19.4° C) WB EAT, or 75° F (23.9° C) DB and 63° F (17.2° C) WB; 45° F (7.2° C) EWT, 10° F Ω (5.6° C Ω) or 12° F Ω (6.7° C Ω) water temperature rise.

# Belt Drive Series

## FAN COIL TECHNICAL CATALOG

### Cooling Capacity Table, Cont'd.

Unit Size	CFM	Rows	EAT (°F) DB/WB	EWT (°F)	ΔT (°F)	Total (MBH)	Sensible (MBH)	GPM	WPD (ft. wg.)
10	900	4	80 / 67	45	10	33.9	23.6	6.0	4.8
					12	30.3	21.7	5.6	6.6
			75 / 63	45	10	22.6	18.6	4.5	3.1
					12	20.8	17.9	3.4	2.0
		6	80 / 67	45	10	36.5	24.8	7.2	9.9
					12	33.9	23.6	5.6	6.6
			75 / 63	45	10	27.0	20.9	5.4	6.1
					12	25.2	20.1	4.2	4.1
		8	80 / 67	45	10	38.6	25.7	7.7	14.4
					12	35.9	24.6	5.9	9.6
			75 / 63	45	10	28.3	21.5	5.6	8.8
					12	26.6	20.8	4.4	6.0
	1000	4	80 / 67	45	10	32.7	23.8	6.5	5.5
					12	30.0	22.7	5.0	3.6
			75 / 63	45	10	24.7	20.4	4.9	3.5
					12	22.8	19.7	3.8	2.3
		6	80 / 67	45	10	39.4	27.2	7.9	11.4
					12	37.1	26.1	6.1	7.6
			75 / 63	45	10	29.6	23.0	5.9	7.1
					12	27.8	22.2	4.6	4.8
		8	80 / 67	45	10	42.6	28.4	8.4	16.8
					12	39.7	27.2	6.6	11.3
			75 / 63	45	10	31.4	23.9	6.2	10.4
					12	29.5	23.1	4.9	7.1
	1100	4	80 / 67	45	10	35.2	25.8	7.0	6.2
					12	32.4	24.7	5.4	4.0
			75 / 63	45	10	26.7	22.3	5.3	4.0
					12	24.7	21.5	4.1	2.6
		6	80 / 67	45	10	43.4	29.7	8.6	12.9
					12	40.3	28.4	6.7	8.6
			75 / 63	45	10	32.4	25.2	6.4	8.2
					12	30.4	24.4	5.0	5.5
		8	80 / 67	45	10	46.5	31.2	9.2	19.3
					12	43.3	29.8	7.2	12.9
			75 / 63	45	10	34.4	26.2	6.8	12.0
					12	32.5	25.4	5.4	8.2

NOTE: Ratings are based on 80° F (26.7° C) DB and 67° F (19.4° C) WB EAT, or 75° F (23.9° C) DB and 63° F (17.2° C) WB; 45° F (7.2° C) EWT, 10° F Ω (5.6° C Ω) or 12° F Ω (6.7° C Ω) water temperature rise.

## Cooling Capacity Table, Cont'd.

Unit Size	CFM	Rows	EAT (°F) DB/WB	EWT (°F)	ΔT (°F)	Total (MBH)	Sensible (MBH)	GPM	WPD (ft. wg.)	
12	1100	4	80 / 67	45	10	35.2	25.8	7.0	6.2	
					12	32.4	24.7	5.4	4.0	
			75 / 63	45	10	26.7	22.3	5.3	4.0	
					12	24.7	21.5	4.1	2.6	
		6	80 / 67	45	10	43.4	29.7	8.6	12.9	
					12	40.3	28.4	6.7	8.6	
			75 / 63	45	10	32.4	25.2	6.4	8.2	
					12	30.4	24.4	5.0	5.5	
			8	80 / 67	45	10	46.5	31.2	9.2	19.3
						12	43.3	29.8	7.2	12.9
		75 / 63		45	10	34.4	26.2	6.8	12.0	
					12	32.5	25.4	5.4	8.2	
	1200	4	80 / 67	45	10	37.7	27.8	7.5	6.8	
					12	34.7	26.6	5.7	4.5	
			75 / 63	45	10	28.7	24.1	5.7	4.5	
					12	26.7	23.3	4.4	3.0	
			6	80 / 67	45	10	46.6	32.1	9.2	14.4
						12	43.4	30.8	7.2	9.7
		75 / 63		45	10	35.0	27.4	6.9	9.2	
			12		32.8	26.5	5.4	6.2		
		8	80 / 67	45	10	50.3	33.9	10.0	21.8	
					12	47.1	32.5	7.8	14.7	
			75 / 63	45	10	37.5	28.6	7.4	13.8	
					12	35.4	27.7	5.8	9.4	
	1300	4	80 / 67	45	10	39.9	29.7	7.9	7.5	
					12	37.0	28.6	6.1	5.0	
			75 / 63	45	10	30.6	25.9	6.1	4.9	
					12	28.5	25.0	4.7	3.3	
			6	80 / 67	45	10	49.9	34.5	9.9	16.1
						12	46.6	33.2	7.7	10.8
		75 / 63		45	10	37.5	29.5	7.4	10.3	
			12		35.4	28.6	5.8	7.0		
		8	80 / 67	45	10	54.0	36.5	10.7	24.4	
					12	50.8	35.1	8.4	16.6	
			75 / 63	45	10	40.4	30.9	8.0	15.5	
					12	38.2	30.0	6.3	10.6	

**NOTE:** Ratings are based on 80° F (26.7° C) DB and 67° F (19.4° C) WB EAT, or 75° F (23.9° C) DB and 63° F (17.2° C) WB; 45° F (7.2° C) EWT, 10° F Ω (5.6° C Ω) or 12° F Ω (6.7° C Ω) water temperature rise.

### Cooling Capacity Table, Cont'd.

Unit Size	CFM	Rows	EAT (°F) DB/WB	EWT (°F)	ΔT (°F)	Total (MBH)	Sensible (MBH)	GPM	WPD (ft. wg.)
16	1400	4	80 / 67	45	10	42.2	31.9	8.4	3.5
					12	38.4	30.4	6.4	2.3
			75 / 63	45	10	32.1	27.7	6.4	2.3
					12	29.4	26.6	4.9	1.5
		6	80 / 67	45	10	50.5	35.8	10.0	7.0
					12	46.9	34.3	7.8	4.7
			75 / 63	45	10	37.9	30.6	7.5	4.5
					12	35.4	29.6	5.9	3.0
		8	80 / 67	45	10	54.3	37.4	10.8	10.5
					12	50.3	35.7	8.3	7.0
			75 / 63	45	10	40.3	31.7	7.99	6.6
					12	37.8	30.6	6.3	4.5
	1600	4	80 / 67	45	10	46.7	35.8	9.3	4.1
					12	42.9	34.3	7.1	2.7
			75 / 63	45	10	36.0	31.3	7.1	2.7
					12	33.2	30.2	5.5	1.8
		6	80 / 67	45	10	56.8	40.6	11.3	8.4
					12	52.7	38.9	8.7	5.6
			75 / 63	45	10	42.9	34.9	8.5	5.4
					12	40.3	33.8	6.7	3.7
		8	80 / 67	45	10	61.6	42.6	12.2	12.9
					12	57.5	40.9	9.5	8.6
			75 / 63	45	10	46.0	36.3	9.1	8.1
					12	43.3	35.6.1	7.2	5.5
	1800	4	80 / 67	45	10	51.2	39.7	10.2	4.7
					12	47.4	38.2	7.8	3.1
			75 / 63	45	10	39.8	34.9	7.9	3.2
					12	36.8	33.7	6.1	2.1
		6	80 / 67	45	10	62.7	45.2	12.4	9.8
					12	58.5	43.5	9.7	6.6
			75 / 63	45	10	47.6	39.0	9.5	6.4
					12	44.9	37.9	7.4	4.4
		8	80 / 67	45	10	68.5	47.7	13.6	15.2
					12	64.1	45.9	10.6	10.2
			75 / 63	45	10	51.5	40.8	10.2	9.7
					12	48.8	39.7	8.1	6.7

NOTE: Ratings are based on 80° F (26.7° C) DB and 67° F (19.4° C) WB EAT, or 75° F (23.9° C) DB and 63° F (17.2° C) WB; 45° F (7.2° C) EWT, 10° F Ω (5.6° C Ω) or 12° F Ω (6.7° C Ω) water temperature rise.

## Cooling Capacity Table, Cont'd.

Unit Size	CFM	Rows	EAT (°F) DB/WB	EWT (°F)	ΔT (°F)	Total (MBH)	Sensible (MBH)	GPM	WPD (ft. wg.)	
20	1800	4	80 / 67	45	10	57.3	42.6	11.4	4.5	
					12	52.6	40.8	8.7	2.9	
			75 / 63	45	10	43.8	37.1	8.7	3.0	
					12	40.4	35.7	6.7	1.9	
		6	80 / 67	45	10	70.0	48.7	13.9	9.3	
					12	65.2	46.7	10.8	6.3	
			75 / 63	45	10	52.7	41.6	10.5	6.0	
					12	49.4	40.2	8.2	4.1	
			8	80 / 67	45	10	89.6	57.4	17.77	18.49
						12	84.3	55.0	13.9	12.6
		75 / 63		45	10	66.3	47.7	13.1	11.5	
					12	62.2	45.9	10.3	7.8	
	2000	4	80 / 67	45	10	61.9	46.5	12.28	5.08	
					12	57.1	44.6	9.43	3.34	
			75 / 63	45	10	47.6	40.6	9.4	3.4	
					12	44.1	39.1	7.3	2.2	
			6	80 / 67	45	10	76.4	53.5	15.2	10.7
						12	71.2	51.3	11.8	7.2
		75 / 63		45	10	57.8	45.9	11.5	6.9	
			12		54.2	44.4	9.0	4.7		
		8	80 / 67	45	10	93.2	61.0	18.5	19.7	
					12	87.7	58.5	14.5	13.4	
			75 / 63	45	10	69.2	51.1	13.7	12.3	
					12	65.2	49.3	10.8	8.4	
	2200	4	80 / 67	45	10	66.4	50.3	13.2	5.7	
					12	61.3	48.3	10.1	3.7	
			75 / 63	45	10	51.2	44.0	10.2	3.8	
					12	47.6	42.5	7.9	2.5	
			6	80 / 67	45	10	82.6	58.2	16.4	12.1
						12	77.2	56.0	12.8	8.2
		75 / 63		45	10	62.8	50.1	12.5	7.9	
			12		59.1	48.5	9.8	5.4		
		8	80 / 67	45	10	95.2	63.9	18.8	20.3	
					12	89.4	61.4	14.8	13.8	
			75 / 63	45	10	71.3	54.2	14.1	12.9	
					12	67.4	52.4	11.1	8.9	

**NOTE:** Ratings are based on 80° F (26.7° C) DB and 67° F (19.4° C) WB EAT, or 75° F (23.9° C) DB and 63° F (17.2° C) WB; 45° F (7.2° C) EWT, 10° F Δ (5.6° C Δ) or 12° F Δ (6.7° C Δ) water temperature rise.

# Belt Drive Series

## FAN COIL TECHNICAL CATALOG

### Cooling Capacity Table, Cont'd.

Unit Size	CFM	Rows	EAT (°F) DB/WB	EWT (°F)	ΔT (°F)	Total (MBH)	Sensible (MBH)	GPM	WPD (ft. wg.)
30	2800	4	80 / 67	45	10	91.9	68.6	18.2	4.6
					12	84.8	65.9	14.0	3.1
			75 / 63	45	10	70.6	59.9	14.0	3.1
					12	65.4	57.8	10.8	2.0
		6	80 / 67	45	10	116.4	80.4	23.1	10.2
					12	109.5	77.5	18.1	7.0
			75 / 63	45	10	88.5	69.1	17.6	6.7
					12	83.3	66.8	13.8	4.5
		8	80 / 67	45	10	131.4	87.4	26.1	16.6
					12	124.7	84.6	20.6	11.5
			75 / 63	45	10	99.5	74.4	19.7	10.7
					12	94.2	72.1	15.6	7.4
	3000	4	80 / 67	45	10	96.4	72.5	19.1	5.0
					12	89.2	69.7	14.7	3.3
			75 / 63	45	10	74.4	63.4	14.8	3.3
					12	69.1	61.2	11.4	2.2
		6	80 / 67	45	10	122.5	85.1	24.3	11.1
					12	115.4	82.2	19.1	7.6
			75 / 63	45	10	93.5	73.3	18.5	7.2
					12	88.1	71.0	14.6	4.9
		8	80 / 67	45	10	139.4	93.0	27.7	18.2
					12	131.9	89.8	21.8	12.5
			75 / 63	45	10	105.5	79.2	20.9	11.8
					12	100.0	76.8	16.5	8.1
	3200	4	80 / 67	45	10	100.8	76.3	20.0	5.4
					12	93.4	73.4	15.4	3.6
			75 / 63	45	10	78.1	66.9	15.5	3.6
					12	72.7	64.6	12.0	2.4
		6	80 / 67	45	10	128.6	89.8	25.5	12.0
					12	121.2	86.8	20.0	8.2
			75 / 63	45	10	98.3	77.5	19.5	7.8
					12	92.9	75.2	15.4	5.4
		8	80 / 67	45	10	146.6	98.3	29.1	19.7
					12	138.6	94.9	22.9	13.5
			75 / 63	45	10	111.1	83.8	22.0	12.8
					12	105.6	81.4	17.5	8.8

NOTE: Ratings are based on 80° F (26.7° C) DB and 67° F (19.4° C) WB EAT, or 75° F (23.9° C) DB and 63° F (17.2° C) WB; 45° F (7.2° C) EWT, 10° F Ω (5.6° C Ω) or 12° F Ω (6.7° C Ω) water temperature rise.



## Cooling Capacity Table, Cont'd.

Unit Size	CFM	Rows	EAT (°F) DB/WB	EWT (°F)	$\Delta T$ (°F)	Total (MBH)	Sensible (MBH)	GPM	WPD (ft. wg.)	
40	3800	4	80 / 67	45	10	120.0	89.4	24.0	9.4	
					12	111.0	86.0	18.5	5.6	
			75 / 63	45	10	89.1	77.0	17.8	5.2	
					12	81.2	73.8	13.5	3.0	
		6	80 / 67	45	10	157.1	108.3	31.4	24.4	
					12	147.9	104.5	24.6	15.0	
			75 / 63	45	10	117.2	92.3	23.4	13.6	
					12	109.2	89.0	18.2	8.2	
			8	80 / 67	45	10	178.7	118.6	35.7	20.4
						12	169.4	114.7	28.2	12.7
		75 / 63		45	10	133.6	100.6	26.7	11.5	
					12	124.9	96.9	20.8	7.0	
	4000	4	80 / 67	45	10	123.8	92.9	24.8	10.0	
					12	114.6	89.3	19.1	6.0	
			75 / 63	45	10	92.0	80.0	18.4	5.6	
					12	84.0	76.8	14.0	3.2	
			6	80 / 67	45	10	162.8	112.8	32.6	26.2
						12	153.2	108.9	25.5	16.1
		75 / 63		45	10	121.5	96.2	24.3	14.7	
			12		113.2	92.8	18.9	8.8		
		8	80 / 67	45	10	185.8	123.8	37.2	22.1	
					12	176.0	119.7	29.3	13.8	
			75 / 63	45	10	138.9	105.1	27.8	12.4	
					12	129.8	101.2	21.6	7.5	
	4200	4	80 / 67	45	10	127.4	96.2	25.5	10.6	
					12	117.9	92.5	19.7	6.3	
			75 / 63	45	10	94.9	83.0	19.0	5.9	
					12	86.7	79.7	14.5	3.4	
			6	80 / 67	45	10	168.3	117.1	33.7	28.0
						12	158.2	113.0	26.4	17.2
		75 / 63		45	10	125.6	100.0	25.1	15.7	
			12		117.1	96.5	19.5	9.5		
		8	80 / 67	45	10	192.6	128.9	38.5	23.8	
					12	182.3	124.5	30.4	14.8	
			75 / 63	45	10	144.0	109.5	28.8	13.3	
					12	134.6	105.5	22.4	8.1	

**NOTE:** Ratings are based on 80° F (26.7° C) DB and 67° F (19.4° C) WB EAT, or 75° F (23.9° C) DB and 63° F (17.2° C) WB; 45° F (7.2° C) EWT, 10° F  $\Omega$  (5.6° C  $\Omega$ ) or 12° F  $\Omega$  (6.7° C  $\Omega$ ) water temperature rise.

### Heating Capacity Table

Unit Size	CFM	Rows	EWT (°F)	ΔT (°F)	MBH	LAT (°F)	GPM	WPD (ft. wg.)		
06	500	1	140	40	7.8	84.2	0.4	0.2		
				20	11.3	90.7	1.1	1.4		
			180	40	16.8	100.6	0.8	0.8		
		20		19.7	106.0	2.0	4.1			
		600	2	140	40	13.2	94.1	0.7	0.1	
					20	18.9	104.6	1.9	1.0	
	180			40	28.2	121.6	1.4	0.5		
			20	32.6	129.6	3.3	2.8			
			700	1	140	40	9.1	83.9	0.5	0.2
	20					13.2	90.2	1.3	2.0	
	180	40			19.6	99.9	1.0	1.0		
		20		23.1	105.2	2.3	5.6			
		800		2	140	40	15.6	93.8	0.8	0.2
	20					22.2	103.9	2.2	1.4	
	180		40		33.1	120.5	1.7	0.7		
			20	38.3	128.4	3.8	3.9			
			900	1	140	40	10.2	83.3	0.5	0.3
	20					14.7	89.3	1.5	2.4	
	180	40			21.8	98.5	1.1	1.3		
		20		25.7	103.6	2.6	7.0			
		08		700	2	140	40	17.6	93.0	0.9
	20						25.0	102.6	2.5	1.7
	180		40			37.2	118.6	1.9	0.9	
			20		43.1	126.4	4.3	4.9		
800			1		140	40	10.2	83.3	0.5	0.3
	20					14.7	89.3	1.5	2.4	
	180	40		21.8	98.5	1.1	1.3			
		20	25.7	103.6	2.6	7.0				
		900	2	140	40	17.6	93.0	0.9	0.2	
	20				25.0	102.6	2.5	1.7		
180	40			37.2	118.6	1.9	0.9			
	20		43.1	126.4	4.3	4.9				
	08		800	1	140	40	11.0	82.6	0.6	0.3
20						15.9	88.2	1.6	2.8	
180		40			23.5	96.9	1.2	1.5		
		20		27.8	101.8	2.8	8.2			
		900		2	140	40	19.2	92.0	1.0	0.3
20						27.2	101.1	2.7	2.1	
180	40		40.5		116.3	2.0	1.1			
	20		47.1	123.8	4.7	5.8				
	900		1	140	40	11.6	81.8	0.6	0.4	
20					16.8	87.1	1.7	3.1		
180		40		24.8	95.2	1.2	1.6			
		20	29.4	99.9	2.9	9.1				
		2	140	40	20.4	90.8	1.0	0.3		
20				29.0	99.5	2.9	2.3			
180	40		43.1	113.8	2.2	1.2				
20	50.3	121.1	5.0	6.7						

NOTES: 1. Based on 70° F (21.1° C) entering air temperature.  
 2. For leaving air temperature above 130° F (54.4° C) consult the factory.

### Heating Capacity Table, Cont'd.

Unit Size	CFM	Rows	EWT (°F)	ΔT (°F)	MBH	LAT (°F)	GPM	WPD (ft. wg.)		
10	900	1	140	40	14.9	85.1	0.7	0.8		
				20	20.2	90.6	2.0	6.0		
		180	2	140	40	30.1	100.6	1.5	3.2	
					20	34.8	105.4	3.5	16.8	
		180	2	180	40	50.9	121.7	2.5	2.3	
					20	57.9	128.9	5.8	11.6	
	1000	1	140	40	16.0	84.6	0.8	1.0		
				20	21.8	89.9	2.2	6.9		
		180	2	140	40	27.7	95.3	1.4	0.7	
					20	36.8	103.7	3.7	4.9	
		180	2	180	40	55.0	120.3	2.8	2.6	
					20	62.8	127.4	6.3	13.6	
	1100	1	140	40	16.9	84.1	0.8	1.1		
				20	23.1	89.2	2.3	7.8		
		180	2	140	40	29.5	94.5	1.5	0.8	
					20	39.3	102.6	3.9	5.6	
		180	2	180	40	58.6	118.8	2.9	3.0	
					20	67.0	125.7	6.7	15.5	
	12	1100	1	140	40	16.9	84.1	0.8	1.1	
					20	23.1	89.2	2.3	7.8	
			180	2	140	40	29.5	94.5	1.5	0.8
						20	39.3	102.6	3.9	5.6
			180	2	180	40	58.6	118.8	2.9	3.0
						20	67.0	125.7	6.7	15.5
1200		1	140	40	17.7	83.5	0.9	1.2		
				20	24.2	88.4	2.4	8.5		
		180	2	140	40	31.0	93.6	1.5	0.9	
					20	41.7	101.7	4.2	24.0	
		180	2	180	40	61.8	117.1	3.1	3.3	
					20	70.7	123.9	7.1	17.2	
1300		1	140	40	18.3	82.9	0.9	1.2		
				20	25.0	87.6	2.5	9.1		
		180	2	140	40	32.3	92.7	1.6	1.0	
					20	43.2	100.4	4.3	6.8	
		180	2	180	40	64.4	115.3	3.2	3.6	
					20	73.8	121.9	7.4	18.8	

NOTES: 1. Based on 70° F (21.1° C) entering air temperature.  
 2. For leaving air temperature above 130° F (54.4° C) consult the factory.

## Heating Capacity Table, Cont'd.

Unit Size	CFM	Rows	EWT (°F)	ΔT (°F)	MBH	LAT (°F)	GPM	WPD (ft. wg.)	
16	1400	1	140	40	19.9	83.0	1.0	0.2	
				20	29.1	89.0	2.9	1.9	
		180	2	140	40	43.1	98.2	2.2	1.0
					20	51.0	103.3	5.1	5.6
		180	2	140	40	37.4	94.5	1.9	0.5
					20	50.6	103.0	5.1	3.5
	180	2	180	40	75.5	119.3	3.8	1.8	
				20	86.5	126.5	8.7	5.4	
	1600	1	140	140	40	21.4	82.2	1.1	0.3
					20	31.4	87.9	3.1	2.2
		180	1	140	40	46.4	96.5	2.3	1.2
					20	54.9	101.4	5.5	6.4
		180	2	140	40	40.6	93.2	2.0	0.6
					20	55.0	101.4	5.5	4.1
	180	2	180	40	82.0	116.9	4.1	2.2	
				20	94.2	123.8	9.4	11.4	
	1800	1	140	140	40	22.6	81.5	1.1	0.3
					20	33.0	86.8	3.3	2.5
		180	1	140	40	48.8	94.8	2.4	1.3
					20	57.8	99.4	5.8	7.2
		180	2	140	40	43.1	91.9	2.2	0.6
					20	58.5	99.7	5.8	4.6
	180	2	180	40	87.1	114.3	4.4	2.5	
				20	100.4	121.0	10.0	12.9	
20	1800	1	140	40	26.2	83.3	1.3	0.5	
				20	36.9	88.8	3.7	3.7	
		180	1	140	40	54.7	97.8	2.7	1.9
					20	64.1	102.6	6.4	10.5
		180	2	140	40	43.7	92.2	2.2	0.3
					20	61.9	101.5	6.2	2.2
	180	2	180	40	92.1	116.8	4.6	1.2	
				20	107.3	124.5	10.7	6.3	
	2000	1	140	140	40	27.6	82.6	1.4	0.5
					20	38.9	87.8	3.9	4.1
		180	1	140	40	57.6	96.3	2.9	2.2
					20	67.6	100.9	6.8	11.7
		180	2	140	40	46.4	91.2	2.3	0.3
					20	65.8	100.1	6.6	2.5
	180	2	180	40	97.8	114.7	4.9	1.3	
				20	114.2	122.2	11.4	7.1	
	2200	1	140	140	40	28.7	81.9	1.4	0.6
					20	40.4	86.8	4.0	4.4
		180	1	140	40	59.9	94.9	3.0	2.3
					20	70.3	99.2	7.0	12.7
		180	2	140	40	48.5	90.2	2.4	0.4
					20	69.0	98.7	6.9	2.7
	180	2	180	40	102.5	112.6	5.1	1.5	
				20	119.8	119.8	12.0	7.9	

NOTES: 1. Based on 70° F (21.1° C) entering air temperature.  
 2. For leaving air temperature above 130° F (54.4° C) consult the factory.

### Heating Capacity Table, Cont'd.

Unit Size	CFM	Rows	EWT (°F)	ΔT (°F)	MBH	LAT (°F)	GPM	WPD (ft. wg.)		
30	2800	1	140	40	30.0	79.8	1.5	0.1		
				20	54.3	87.7	5.4	0.7		
		180	2	140	40	79.8	96.1	4.0	0.4	
					20	97.1	101.7	9.7	2.2	
		180	2	180	40	144.2	117.1	7.2	0.9	
					20	167.7	124.8	16.8	5.0	
	3000	1	140	40	31.5	79.6	1.6	0.1		
				20	56.3	87.1	5.6	0.8		
		180	2	140	40	82.7	95.2	4.1	0.4	
					20	100.7	100.7	10.1	2.3	
		180	2	180	40	150.2	115.8	7.5	1.0	
					20	174.9	123.3	17.5	5.5	
	3200	1	140	40	32.7	79.4	1.6	0.1		
				20	57.9	86.6	5.8	0.8		
		180	2	140	40	85.1	94.3	4.3	0.4	
					20	103.7	99.6	10.4	2.5	
		180	2	180	40	73.3	91.0	3.7	0.3	
					20	104.6	99.9	10.5	2.1	
	40	3800	1	140	40	50.8	82.2	2.5	0.2	
					20	76.2	88.3	7.6	1.8	
			180	2	140	40	112.5	97.1	5.6	1.0
						20	133.8	102.2	13.4	5.3
			180	2	180	40	99.9	94.0	5.0	0.6
						20	134.3	102.3	13.4	4.4
180		2	180	40	200.5	118.3	10.0	2.3		
				20	229.8	125.3	23.0	12.2		
4000		1	140	40	52.2	81.9	2.6	0.2		
				20	78.2	87.9	7.8	1.9		
		180	2	140	40	115.5	96.4	5.8	1.0	
					20	137.5	101.4	13.8	5.6	
		180	2	180	40	103.0	93.5	5.1	0.7	
					20	138.5	101.7	13.9	4.7	
180		2	180	40	206.7	117.3	10.3	2.5		
				20	237.2	124.2	23.7	13.0		
4200		1	140	40	53.5	81.7	2.7	0.2		
				20	80.1	87.4	8.0	2.0		
		180	2	140	40	118.2	95.7	5.9	1.1	
					20	140.8	100.7	14.1	5.9	
		180	2	180	40	105.7	93.0	5.3	0.7	
					20	142.4	101.0	14.2	4.9	
180		2	180	40	212.4	116.3	10.6	2.6		
				20	244.0	123.1	24.4	13.7		

NOTES: 1. Based on 70° F (21.1° C) entering air temperature.  
 2. For leaving air temperature above 130° F (54.4° C) consult the factory.

### Component Static Resistance (in w.c.)

Unit Size	Nominal CFM	Coil(includes cabinet)					Filters							Mixing Box
		Dry					1" Throw-away	1" MERV 8 Pleated	(Qty. 2) 1" Throw-away	2" MERV 8 Pleated	2" MERV 11 w/Prefilter	4" MERV 11 Pleated	4" MERV 13 Pleated	
		4 Row	5 Row	6 Row	7 Row	8 Row								
06	400	0.07	0.08	0.10	0.11	0.12	0.04	0.07	0.05	0.04	0.04	0.03	0.04	0.02
	500	0.11	0.13	0.16	0.18	0.19	0.06	0.11	0.07	0.05	0.06	0.05	0.06	0.03
	600	0.15	0.19	0.22	0.24	0.27	0.08	0.14	0.09	0.06	0.07	0.06	0.08	0.04
	700	0.20	0.24	0.28	0.31	0.34	0.10	0.17	0.11	0.08	0.09	0.08	0.10	0.06
	800	0.24	0.29	0.34	0.38	0.42	0.12	0.21	0.14	0.09	0.11	0.09	0.12	0.08
08	600	0.15	0.19	0.22	0.24	0.27	0.08	0.14	0.09	0.06	0.07	0.06	0.08	0.04
	700	0.20	0.24	0.28	0.31	0.34	0.10	0.17	0.11	0.08	0.09	0.08	0.10	0.06
	800	0.24	0.29	0.34	0.38	0.42	0.12	0.21	0.14	0.09	0.11	0.09	0.12	0.08
	900	0.28	0.34	0.40	0.45	0.49	0.14	0.24	0.16	0.10	0.12	0.10	0.14	0.10
	1000	0.33	0.40	0.46	0.52	0.57	0.16	0.27	0.18	0.12	0.14	0.12	0.16	0.12
10	800	0.12	0.14	0.16	0.18	0.21	0.06	0.10	0.08	0.06	0.13	0.05	0.05	0.04
	900	0.15	0.18	0.21	0.24	0.26	0.07	0.12	0.09	0.07	0.16	0.06	0.06	0.05
	1000	0.19	0.22	0.26	0.29	0.32	0.09	0.14	0.11	0.08	0.18	0.07	0.07	0.06
	1100	0.22	0.26	0.30	0.34	0.37	0.10	0.16	0.13	0.09	0.21	0.08	0.08	0.08
	1200	0.25	0.30	0.35	0.39	0.43	0.11	0.18	0.14	0.10	0.23	0.09	0.09	0.09
12	1000	0.19	0.22	0.26	0.29	0.32	0.09	0.14	0.11	0.08	0.18	0.07	0.07	0.06
	1100	0.22	0.26	0.30	0.34	0.37	0.10	0.16	0.13	0.09	0.21	0.08	0.08	0.08
	1200	0.25	0.30	0.35	0.39	0.43	0.11	0.18	0.14	0.10	0.23	0.09	0.09	0.09
	1300	0.29	0.34	0.40	0.44	0.48	0.13	0.19	0.16	0.11	0.25	0.10	0.10	0.11
	1400	0.32	0.38	0.44	0.49	0.54	0.14	0.21	0.18	0.12	0.28	0.11	0.11	0.13
16	1400	0.19	0.23	0.28	0.31	0.34	0.11	0.14	0.17	0.10	0.21	0.09	0.09	0.07
	1500	0.22	0.26	0.31	0.35	0.38	0.12	0.16	0.19	0.10	0.24	0.10	0.10	0.09
	1600	0.24	0.29	0.35	0.38	0.42	0.13	0.17	0.21	0.11	0.26	0.11	0.11	0.10
	1700	0.27	0.32	0.38	0.42	0.47	0.14	0.19	0.22	0.12	0.28	0.12	0.12	0.11
	1800	0.29	0.35	0.42	0.46	0.51	0.15	0.20	0.24	0.13	0.30	0.12	0.13	0.12
20	1800	0.22	0.27	0.32	0.37	0.42	0.11	0.18	0.17	0.11	0.24	0.10	0.13	0.07
	1900	0.24	0.30	0.36	0.41	0.46	0.12	0.19	0.18	0.12	0.26	0.11	0.14	0.08
	2000	0.27	0.33	0.39	0.45	0.50	0.13	0.21	0.20	0.13	0.28	0.12	0.15	0.09
	2100	0.29	0.36	0.42	0.49	0.55	0.14	0.22	0.21	0.13	0.30	0.13	0.16	0.10
	2200	0.31	0.39	0.46	0.53	0.59	0.15	0.24	0.23	0.14	0.32	0.14	0.17	0.11
	2300	0.34	0.42	0.49	0.57	0.64	0.16	0.25	0.25	0.15	0.34	0.15	0.18	0.12
	2400	0.36	0.44	0.53	0.60	0.68	0.17	0.27	0.26	0.16	0.36	0.16	0.20	0.13
	2400	0.17	0.21	0.24	0.28	0.33	0.09	0.15	0.14	0.10	0.19	0.07	0.11	0.07
30	2600	0.20	0.24	0.28	0.33	0.38	0.10	0.16	0.16	0.11	0.22	0.08	0.13	0.09
	2800	0.23	0.27	0.32	0.38	0.43	0.11	0.18	0.17	0.12	0.24	0.09	0.14	0.10
	3000	0.26	0.31	0.36	0.42	0.49	0.13	0.20	0.19	0.14	0.26	0.10	0.16	0.11
	3200	0.29	0.34	0.40	0.47	0.54	0.14	0.22	0.21	0.15	0.28	0.12	0.18	0.13
	3400	0.32	0.38	0.44	0.52	0.59	0.15	0.24	0.23	0.16	0.31	0.13	0.19	0.15
	3400	0.11		0.17		0.22		0.15	0.09	0.12	0.24			0.08
40	3600	0.12		0.19		0.25		0.16	0.10	0.13	0.27			0.09
	3800	0.14		0.21		0.28		0.18	0.11	0.15	0.30			0.11
	4000	0.15		0.23		0.31		0.20	0.12	0.16	0.33			0.12
	4200	0.17		0.25		0.34		0.22	0.13	0.18	0.37			0.13
	4400	0.19		0.28		0.37		0.25	0.14	0.20	0.40			0.14

**HBD/VBA Fan Curves**

**HBD/VBA-06**

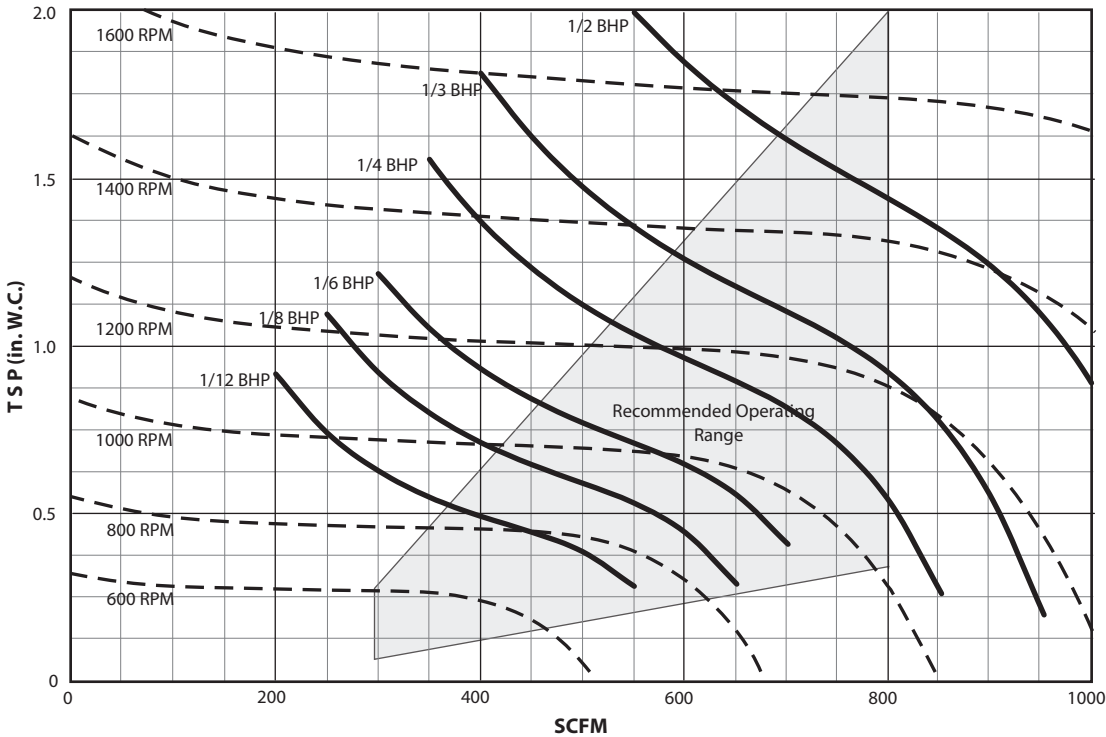

**HBD/VBA-08**

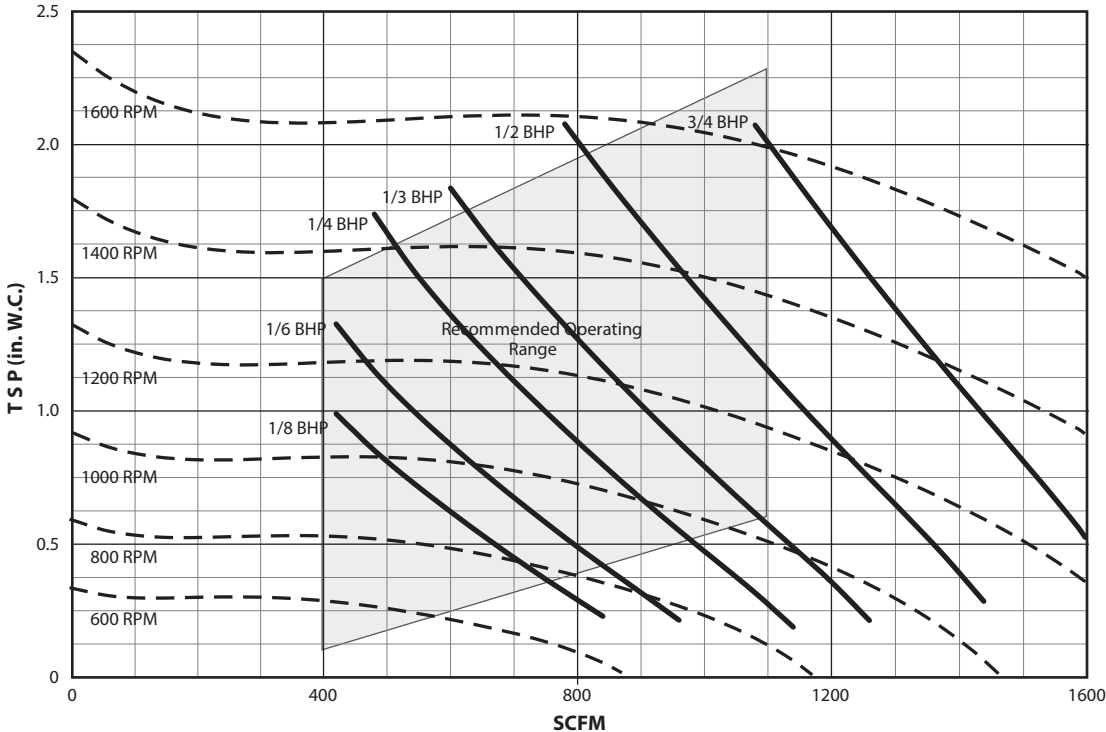

**HBD/VBA Fan Curves, Cont'd.**

**HBD/VBA-10**

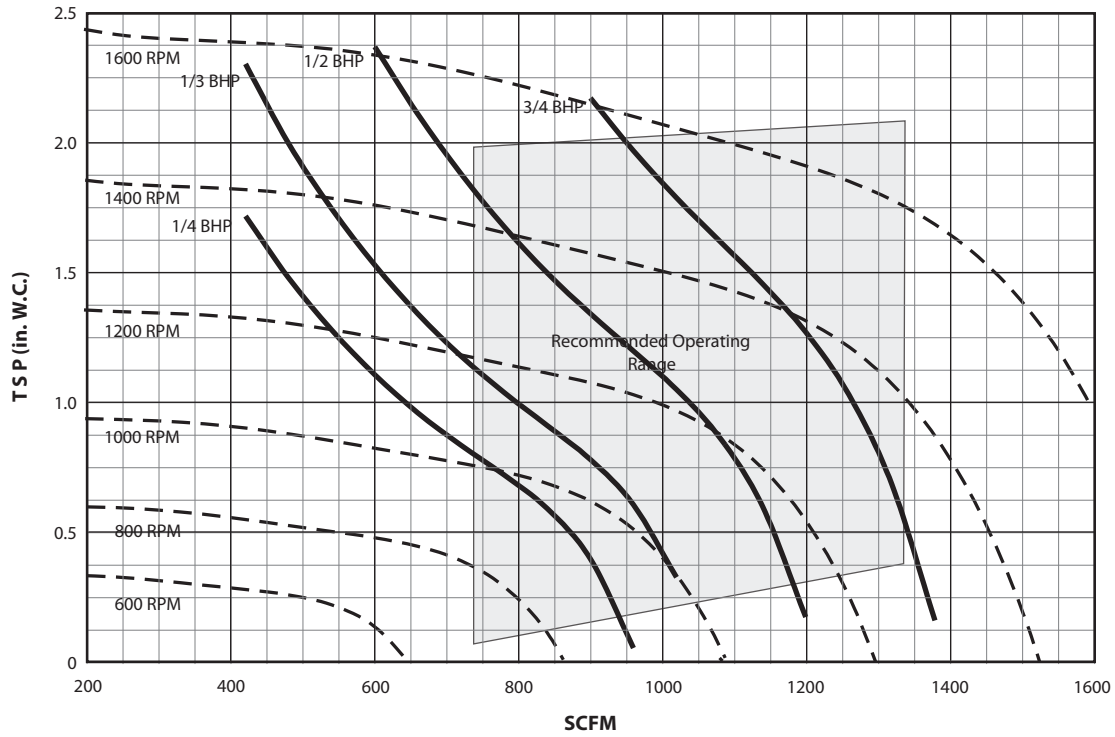

**HBD/VBA-12**

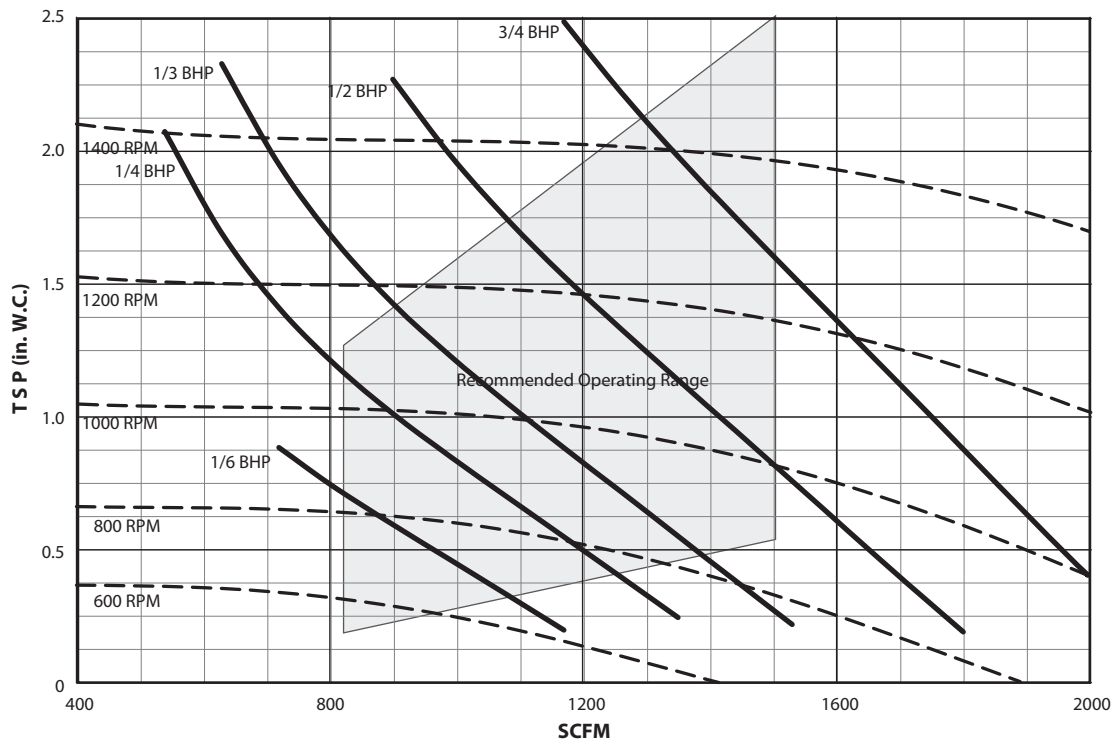



**HBD/VBA Fan Curves, Cont'd.**

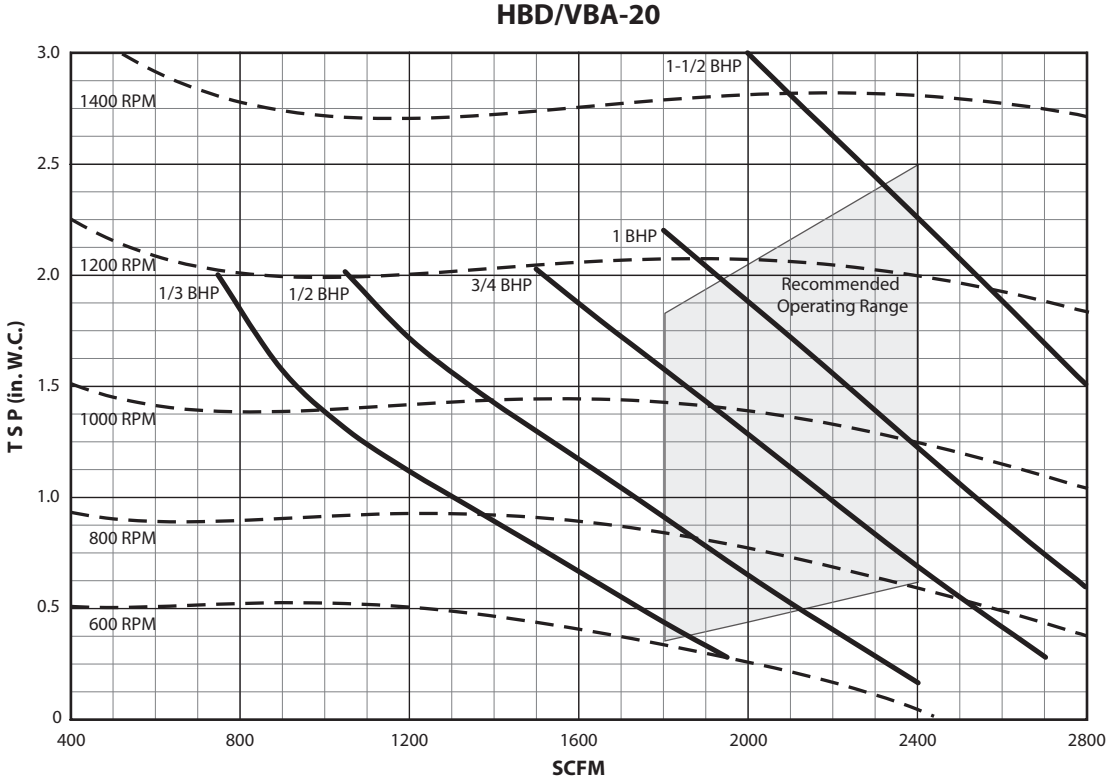
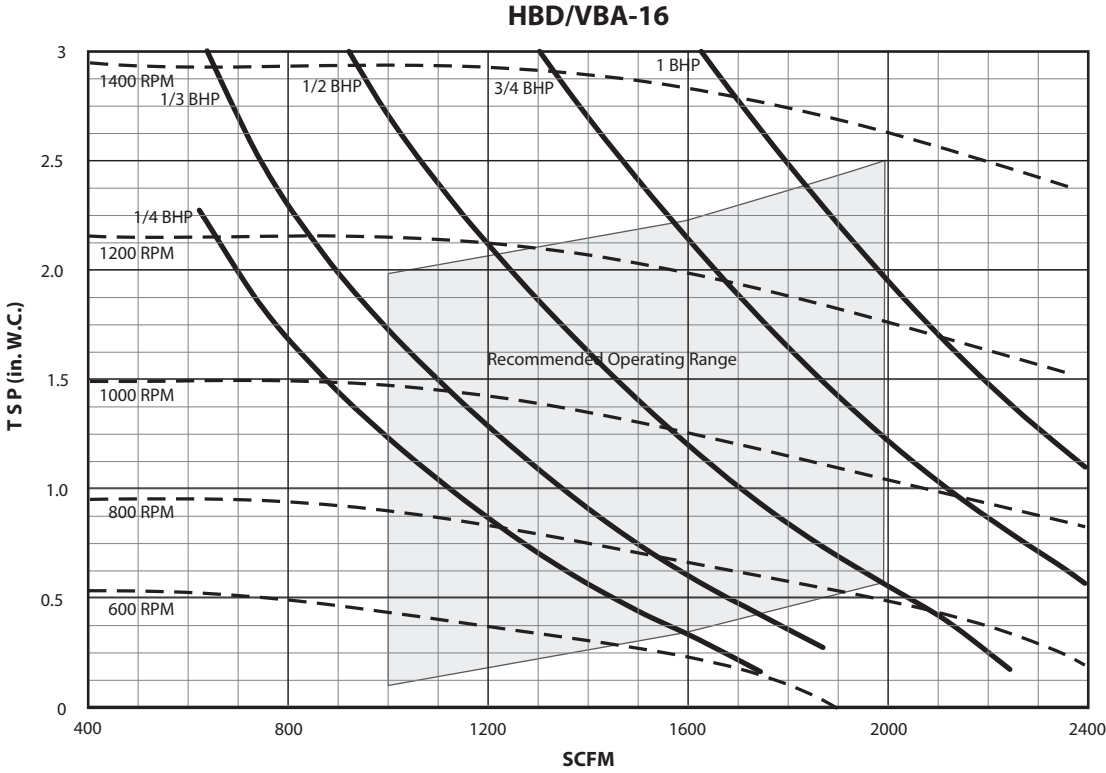

**HBD/VBA Fan Curves, Cont'd.**

**HBD/VBA-30**

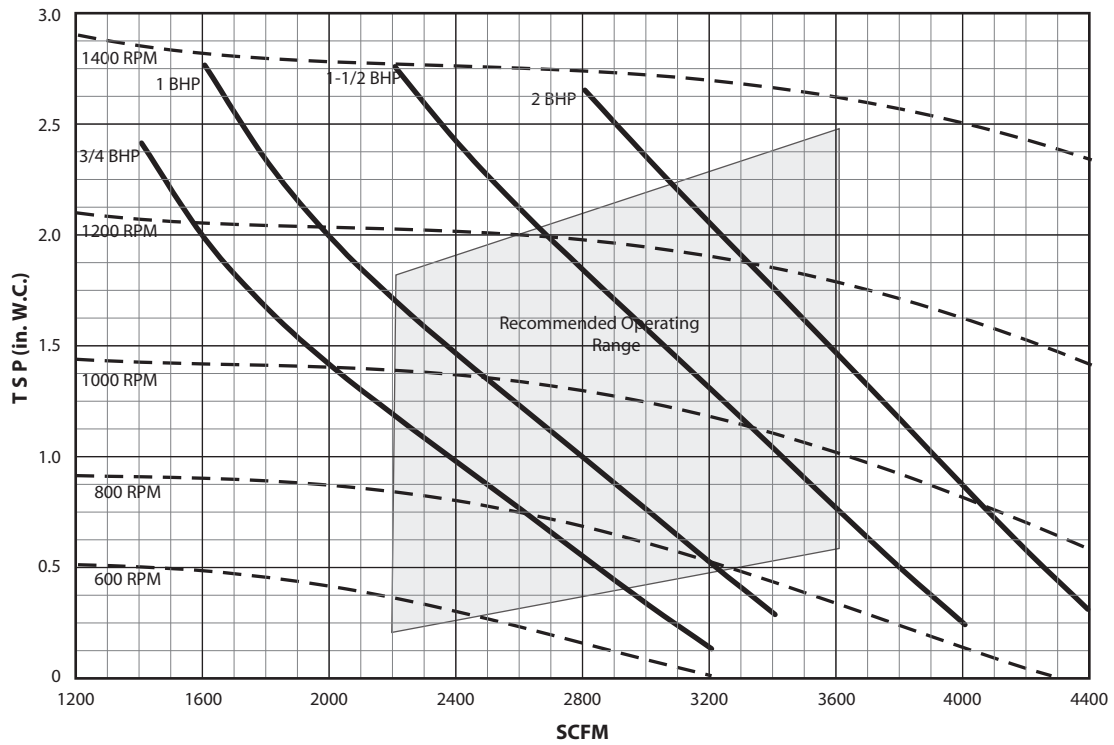

**HBD/VBA-40**

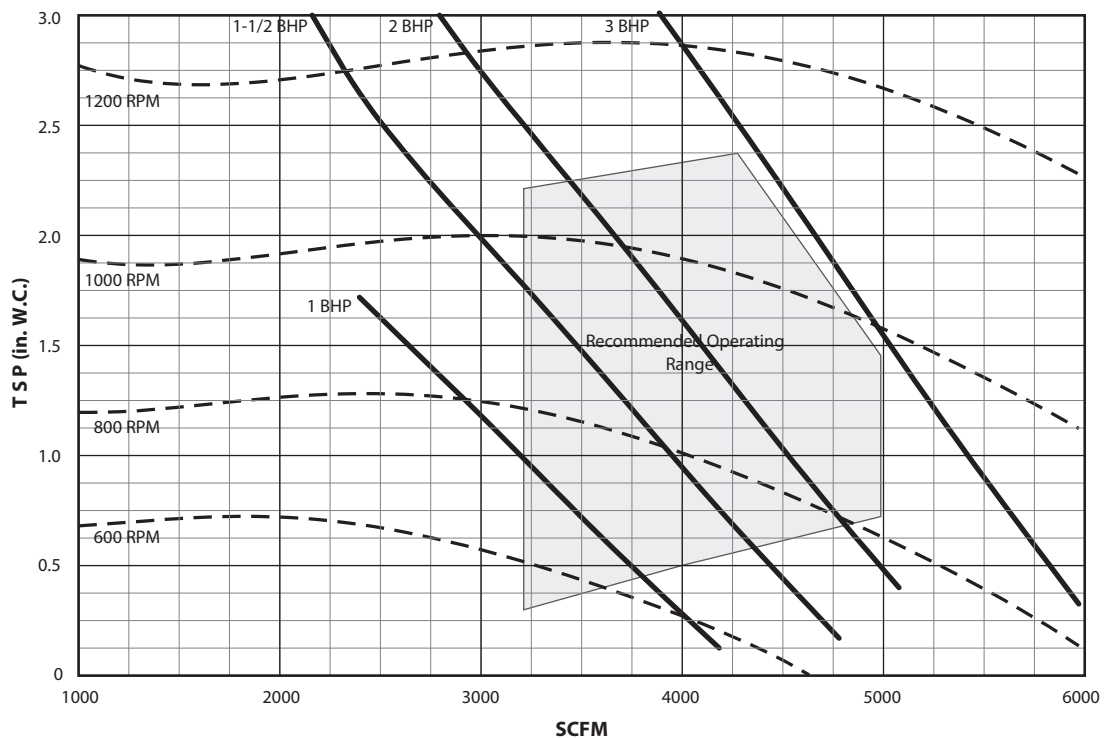

## Motor Data

### Thermal Overload Protection

All standard motors on belt-driven units furnished by IEC contain internal thermal overload protection. The overload automatically resets when the temperature returns to a safe limit. These thermal overloads, when coupled with motor contactors, replace the need for motor starters.

### Motor Full Load Amps Data - HBD/VBA

Voltage	Nominal HP							
	1/4	1/3	1/2	3/4	1	1-1/2	2	3
115 V 60 Hz 1-Phase	5.2	6.0	8.6	13.3	14.4	-	-	-
208 V 60 Hz 1-Phase	3.0	3.6	4.8	6.6	7.4	9.4	11.0	-
230 V 60 Hz 1-Phase	2.5	3.0	4.2	5.1	6.0	9.0	10.9	-
277 V 60 Hz 1-Phase	2.1	2.5	3.6	5.1	5.4	8.5	8.0	-
208 V 60 Hz 3-Phase	-	-	2.4	3.6	3.8	6.0	6.5	8.2
230 V 60 Hz 3-Phase	-	-	2.2	3.0	3.2	4.8	6.2	8.4
460 V 60 Hz 3-Phase	-	-	1.1	1.5	1.9	2.8	3.1	4.2

- NOTES: 1. Motor full load Amps refer to National Electric Code (NEC) Amps; actual motor nameplate amps may vary.  
 2. NEC data extrapolated for 277 V.  
 3. Motors are open drip proof, ball bearing, single speed, 1750 RPM rated at continuous duty, 40° C (104° F) ambient with reversible rotation.

### Inverter Duty Motor Full Load Amps Data - HBD/VBA

Voltage	Nominal HP							
	1/4	1/3	1/2	3/4	1	1-1/2	2	3
208V 60 Hz 3-Phase	-	-	-	2.4	3.1	4.5	5.8	8.5
230 V 60 Hz 3-Phase	-	-	-	3.0	3.2	4.8	6.2	8.4
460 V 60 Hz 3-Phase	-	-	-	-	1.9	2.8	3.1	4.2

- NOTES: 1. Motor full load amps refer to National Electric Code (NEC) Amps; actual motor nameplate amps may vary.  
 2. Motors are open drip proof, ball bearing, single speed, 1750 RPM rated at continuous duty, 40° C (104° F) ambient with reversible rotation.

### Motor and Drive Selection

Use IEC's Rating Program to determine motor and drive selection for your specific applications. If the Rating Program is not available, follow these steps:

- To determine motor and drive selection requirements for a given airflow, the total static pressure (TSP) for that airflow must be determined. The TSP is the sum of the internal static pressure (ISP) and the external static pressure (ESP) measured in inches of water column. ISP is the sum of the static resistance of the components of the unit – the cabinet, coil and filter. ESP is the static resistance of the external components of the unit, including, but not limited to, mixing boxes, ductwork, grilles and additional filtration. For non-ducted, non-mixing box applications, the ESP is 0".
- After the TSP has been calculated (see the following example), use the Fan Curves (pages 23 through 26) to determine the brake horsepower (BHP) and the corresponding RPM for your belt drive unit. HP offerings are limited to 1/4, 1/3, 1/2, 3/4, 1, 1-1/2, 2, and 3. The standard selection for the motor is the nearest offering above the actual BHP shown in the Fan Curve.
- Drive sheaves and the required belt assembly will be provided to meet your design requirements. Drive sheaves are set at the factory.

#### Example

Calculate the HP and drive selection required to deliver 1500 CFM on an HBD 16 equipped with a 4-row hydronic cooling coil and a 2" pleated filter in a ducted application at 0.38" ESP, including duct and grille losses.

Using the Component Static Resistance Table on the next page, calculate the ISP as follows:

Cabinet	0.09"
4-Row Wet Coil	0.30"
2" Pleated Filter	<u>+ 0.12"</u>
ISP	0.51"
ESP	<u>+ 0.38"</u>
TSP	0.89"

Round the TSP to 0.9". From fan curve on page 29, a BHP of 0.38 and RPM of 890 is required. A nominal 1/2 HP motor will be required. Supply the CFM and external static pressure with your order.

### Sound Power Data – HBD

UNIT SIZE	RATING	FAN SPEED	CFM	SOUND POWER LEVEL, Lw (dB reference one picowatt)							A-wgt (dBA)
				125 Hz	250 Hz	500 Hz	1K Hz	2K Hz	4K Hz	8K Hz	
6 (Note 4)	CASING RADIATED (Note 2)	1050	600	76	65	62	56	51	45	40	64
	DUCTED DISCHARGE (Note 3)			70	61	59	59	56	53	47	64
8	CASING RADIATED (Note 2)	1125	880	70	67	60	57	52	46	40	63
	DUCTED DISCHARGE (Note 3)			65	60	61	60	58	56	50	65
10	CASING RADIATED (Note 2)	1225	1000	76	75	65	64	60	54	49	70
	DUCTED DISCHARGE (Note 3)			78	73	71	71	66	63	58	75
12	CASING RADIATED (Note 2)	970	1200	70	66	59	58	55	50	44	64
	DUCTED DISCHARGE (Note 3)			68	62	63	62	58	57	50	66
16	CASING RADIATED (Note 2)	835	1600	69	67	58	57	53	47	40	63
	DUCTED DISCHARGE (Note 3)			69	63	63	64	58	56	47	67
20	CASING RADIATED (Note 2)	860	2085	75	68	62	59	56	51	43	66
	DUCTED DISCHARGE (Note 3)			69	66	69	65	63	62	54	71
30	CASING RADIATED (Note 2)	850	3000	77	70	66	63	59	55	47	69
	DUCTED DISCHARGE (Note 3)			70	70	70	66	65	64	57	73
40	CASING RADIATED (Note 2)	715	4050	73	68	68	63	60	61	46	70
	DUCTED DISCHARGE (Note 3)			69	70	72	66	65	64	56	73

- NOTES:**
- Unit Test Configuration: Rear Return/Front Supply, 4 Row, 10 FPI Coil, 460/3 PH/60 Hz VAC Motor, 1" dual density fiberglass insulations.
  - Testing per AHRI 260-2001: 4.2.2.3 Casing radiated with free inlet, Sound Rating of Ducted Air Moving and Conditioning Equipment.
  - Testing per AHRI 260-2001: 4.2.2.1 Ducted discharge, Sound Rating of Ducted Air Moving and Conditioning Equipment.
  - Size 06 Unit Test Configuration: Rear Return/Front Supply, 4 Row, 10 FP1 Coil, 230/1 PH/60 Hz VAC PSC Motor.
  - Sound power data is expressed in decibels, dB RE: 1 x 10<sup>-12</sup> w(picowatts).

### Sound Power Data – VBA

UNIT SIZE	RATING	FAN SPEED	CFM	SOUND POWER LEVEL, Lw (dB reference one picowatt)							A-wgt (dBA)
				125 Hz	250 Hz	500 Hz	1K Hz	2K Hz	4K Hz	8K Hz	
6 (Note 4)	CASING RADIATED (Note 2)	1050	640	79	73	66	60	58	60	56	70
	DUCTED DISCHARGE (Note 3)			74	66	57	62	58	52	44	62
8	CASING RADIATED (Note 2)	1055	800	76	67	62	58	53	50	47	65
	DUCTED DISCHARGE (Note 3)			69	64	54	54	52	49	41	61
10	CASING RADIATED (Note 2)	1205	1055	79	74	64	61	58	54	47	69
	DUCTED DISCHARGE (Note 3)			76	73	68	72	68	63	57	70
12	CASING RADIATED (Note 2)	980	1170	73	68	61	58	53	45	41	64
	DUCTED DISCHARGE (Note 3)			68	61	62	65	61	56	50	63
16	CASING RADIATED (Note 2)	920	1660	77	72	64	62	56	49	44	68
	DUCTED DISCHARGE (Note 3)			71	66	68	69	60	56	47	66
20	CASING RADIATED (Note 2)	855	2010	76	66	59	58	54	47	41	65
	DUCTED DISCHARGE (Note 3)			71	66	71	67	63	59	51	66
30	CASING RADIATED (Note 2)	915	3085	79	70	65	63	59	54	48	69
	DUCTED DISCHARGE (Note 3)			72	71	75	72	66	64	56	70
40	CASING RADIATED (Note 2)	790	4145	78	67	63	61	57	54	43	67
	DUCTED DISCHARGE (Note 3)			70	73	74	72	68	65	58	71

- NOTES: 1. Unit Test Configuration: Rear Return/Front Supply, 4 Row, 10 FPI Coil, 460/3 PH/60 Hz VAC Motor, 1" dual density fiberglass insulations.  
 2. Testing per AHRI 260-2001: 4.2.2.3 Casing radiated with free inlet, Sound Rating of Ducted Air Moving and Conditioning Equipment.  
 3. Testing per AHRI 260-2001: 4.2.2.1 Ducted discharge, Sound Rating of Ducted Air Moving and Conditioning Equipment.  
 4. Size 06 Unit Test Configuration: Rear Return/Front Supply, 4 Row, 10 FP1 Coil, 230/1 PH/60 Hz VAC PSC Motor.  
 5. Sound power data is expressed in decibels, dB RE: 1 x 10<sup>-12</sup> w(picowatts).

## Electrical Resistance Heating

Electric heaters are available on IEC Belt Drive blower coils for total electric heat and 2-pipe CW/HW with auxiliary electric heat applications.

### Total Electric Heat

Total electric heat eliminates the requirement for a boiler and provides heating and/or cooling on an individual basis throughout the year. Electric heat is available only for single source power (motor and heater voltage the same).

### Heater Construction

The heater coils of high-grade resistance wire are supported by ceramic insulators on plated steel brackets. These heat elements are suspended directly in front of the outlet after the blower and the coil. An auto and a manual thermal limit switch protect the heater in the event of air failure. For electric heat control options refer to page 39.

### Electric Heater Selection

kW	Heater Availability								Full Load Amps						
									Single Phase			Three Phase			
	6	8	10	12	16	20	30	40	120 V	208 V	240 V	277 V	208 V	240 V	480 V
1	•	•	-	-	-	-	-	-	8.3	4.8	4.2	3.6	2.8	2.4	1.2
1.5	•	•	•	•	-	-	-	-	12.5	7.2	6.3	5.4	4.2	3.6	1.8
2	•	•	•	•	-	-	-	-	16.7	9.6	8.3	7.2	5.6	4.8	2.4
2.5	•	•	•	•	•	-	-	-	20.8	12.0	10.4	9.0	6.9	6.0	3.0
3	•	•	•	•	•	-	-	-	25.0	14.4	12.5	10.8	8.3	7.2	3.6
3.5	•	•	•	•	•	•	-	-	29.2	16.8	14.6	12.6	9.7	8.4	4.2
4	•	•	•	•	•	•	-	-	33.3	19.2	16.7	14.4	11.1	9.6	4.8
4.5	•	•	•	•	•	•	-	-	37.5	21.6	18.8	16.2	12.5	10.8	5.4
5	•	•	•	•	•	•	-	-	-	24.0	20.8	18.1	13.9	12.0	6.0
6	•	•	•	•	•	•	•	•	-	28.8	25.0	21.7	16.7	14.4	7.2
7	-	•	•	•	•	•	•	•	-	33.7	29.2	25.3	19.4	16.8	8.4
8	-	•	•	•	•	•	•	•	-	38.5	33.3	28.9	22.2	19.2	9.6
9.9	-	-	•	•	•	•	•	•	-	-	-	35.7	27.5	23.8	11.9
12	-	-	-	•	•	•	•	•	-	-	-	43.3	33.3	28.9	14.4
14	-	-	-	-	•	•	•	•	-	-	-	-	38.9	33.7	16.8
15	-	-	-	-	•	•	•	•	-	-	-	-	41.6	36.1	18.0
16	-	-	-	-	•	•	•	•	-	-	-	-	-	38.5	19.2
18	-	-	-	-	-	•	•	•	-	-	-	-	-	-	21.7
19.9	-	-	-	-	-	•	•	•	-	-	-	-	-	-	23.9
25	-	-	-	-	-	-	•	•	-	-	-	-	-	-	30.1
30	-	-	-	-	-	-	-	•	-	-	-	-	-	-	36.1
35	-	-	-	-	-	-	-	-	•	-	-	-	-	-	42.1
39.9	-	-	-	-	-	-	-	-	-	-	-	-	-	-	48.0

NOTES: 1. Electric heaters are available for 1-stage (single-stage), 2-stage, or 3-stage applications depending on power phase and heater kW.

Single-Phase Power:

1-12 kW: 1-stage available

3-12 kW: 2-stage available

3-Phase Power:

1-39.9 kW: 1-stage available

4-39.9 kW: 2-stage available

12-39.9 kW: 3-stage available

2. Electric Heating Capacities (BTUH) = Heater kW x 3413

3. Electric Heater Amperage for Single-Phase Power = (Heater kW x 1000)/Applied Voltage

Electric Heater Amperage for 3-Phase Power = (Heater kW x 1000)/(Applied Voltage x 1.73)

### Physical Data

#### HBD Basic Unit – Horizontal Belt Drive

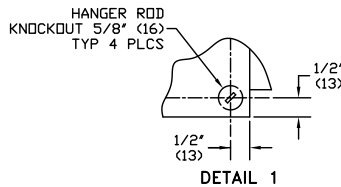
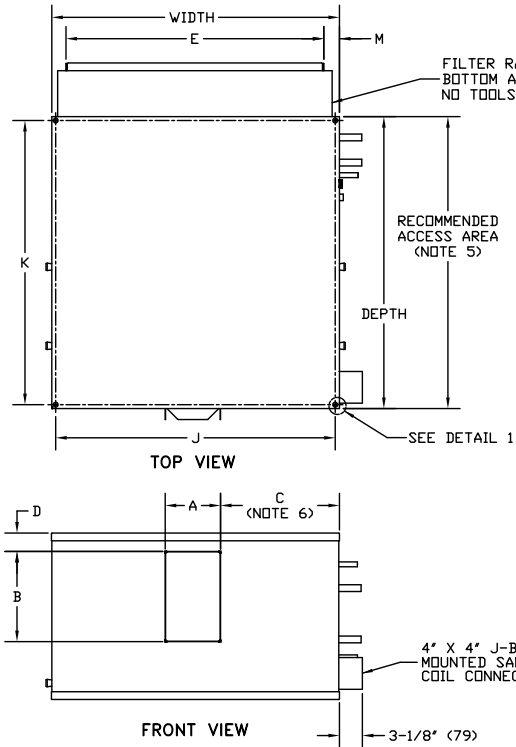

Drawing is not to scale and is provided for reference only. Dimensions may vary with options ordered. Consult IEC web site for up to date drawings.

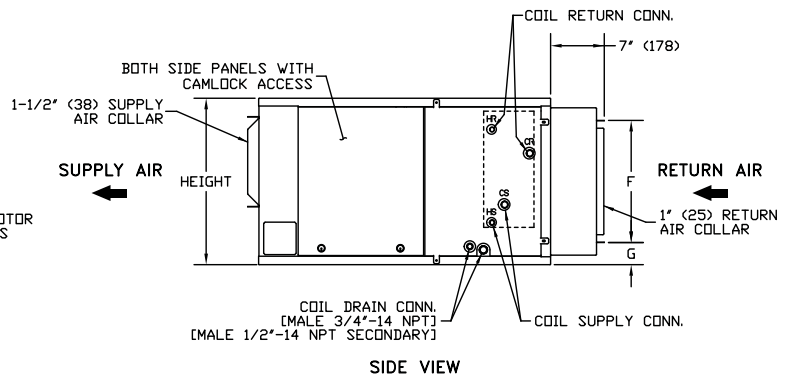

Size	Fan Size	Depth	Width	Height	Supply Duct				Return Duct			Mounting Holes		M
					A	B	C	D	E	F	G	J	K	
06	9x4	36 (914)	28 (711)	19-3/4 (502)	7-1/8 (181)	10-1/2 (267)	14-1/2 (368)	2-1/4 (57)	24-1/4 (616)	14 (356)	2-3/4 (70)	27-1/4 (686)	35-1/4 (895)	2 (51)
08	9x6	36 (914)	28 (711)	19-3/4 (502)	8-1/2 (216)	10-1/2 (267)	14 (356)	2-1/4 (57)	24-1/4 (616)	14 (356)	2-3/4 (70)	27-1/4 (686)	35-1/4 (895)	2 (51)
10	10x4	37-1/2 (953)	37 (940)	21-1/2 (546)	7-1/8 (181)	11-5/8 (295)	15-1/4 (387)	2-1/4 (57)	33-1/4 (845.4)	15-3/4 (401)	2-7/8 (73)	36-1/4 (921)	37 (940)	2 (51)
12	10x7	37-1/2 (953)	37 (940)	21-1/2 (546)	10 (254)	11-5/8 (295)	14 (356)	2-1/4 (57)	33-1/4 (845)	15-3/4 (401)	2-7/8 (73)	36-1/4 (921)	37 (940)	2 (51)
16	11x10	37-3/4 (959)	47 (1194)	21-1/2 (546)	13-3/8 (340)	12-3/4 (324)	16-3/4 (425)	2-1/4 (57)	43-7/8 (1115)	15-3/4 (401)	2-7/8 (73)	46-1/4 (1175)	37 (940)	1-1/2 (38)
20	12x9	40-1/4 (1022)	48 (1219)	24 (610)	12-1/2 (216)	13-3/4 (349)	17-3/4 (451)	2-1/4 (57)	44-1/4 (1124)	18 (457)	2-7/8 (73)	47-1/4 (1200)	39-1/2 (1033)	2 (51)
30	12x12	40-1/4 (1022)	48 (1219)	32-1/4 (819)	15-7/8 (403)	13-3/4 (349)	16 (406)	7-1/4 (184)	44-1/4 (1124)	26-1/2 (673)	1-1/4 (32)	47-1/4 (1200)	39-1/2 (1033)	2 (51)
40	15x12	43-1/2 (1105)	62 (1575)	32-1/4 (819)	16-3/8 (416)	16-1/8 (410)	22-3/4 (578)	6-1/4 (159)	58-1/4 (1480)	26-1/2 (673)	1-1/4 (32)	61-1/4 (1556)	42-1/2 (1080)	2 (51)

- NOTES: \*
- Unit measurements on drawings and in tables are shown in inches and (millimeters).
  - Right hand shown, Left hand opposite.
  - All dimensions are +/- 1/4" (6 mm).
  - Dimensions in parenthesis are in millimeters.
  - Product specifications are subject to changes without notice.
  - Allow adequate spacing for maneuverability around unit to allow service through recommended access area.
  - "C" dimension is measured from coil side of unit.
  - Mixing Box option will vary return duct dimensions, refer to mixing box submittal.



**Physical Data, Cont'd.**

**HBD Unit with Optional Electric Heat**

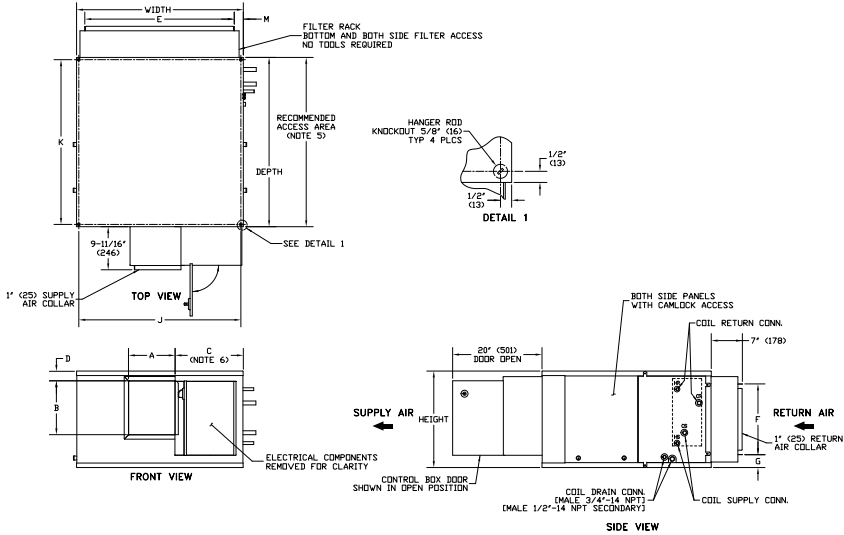

**HBD Unit with Optional Motor Controls**

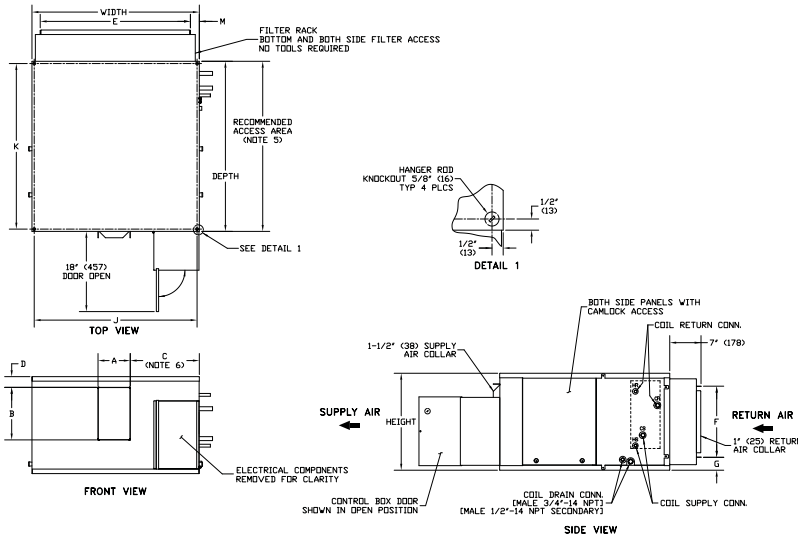

Size	Supply Duct Dimensions - Inches (Millimeters)				M
	A	B	C	D	
06	8-7/8 (225)	10-1/2 (267)	14-1/2 (368)	2-1/4 (57)	2 (51)
08	8-7/8 (225)	10-1/2 (267)	14 (356)	2-1/4 (57)	2 (51)
10	10-3/8 (264)	11-5/8 (295)	15-1/4 (387)	2-1/4 (57)	2 (51)
12	10-3/8 (264)	11-5/8 (295)	14 (356)	2-1/4 (57)	2 (51)
16	13-7/8 (352)	12-3/4 (324)	16-3/4 (425)	2-1/4 (57)	1-1/2 (38)
20	13 (330)	13-3/4 (349)	17-3/4 (451)	2-1/4 (57)	2 (51)
30	16-1/4 (413)	13-3/4 (349)	16 (406)	7-1/4 (184)	2 (51)
40	16-3/4 (425)	16-1/8 (410)	22-3/4 (578)	6-1/4 (159)	2 (51)

### Physical Data, Cont'd.

#### VBA Basic Unit – Vertical Belt Drive

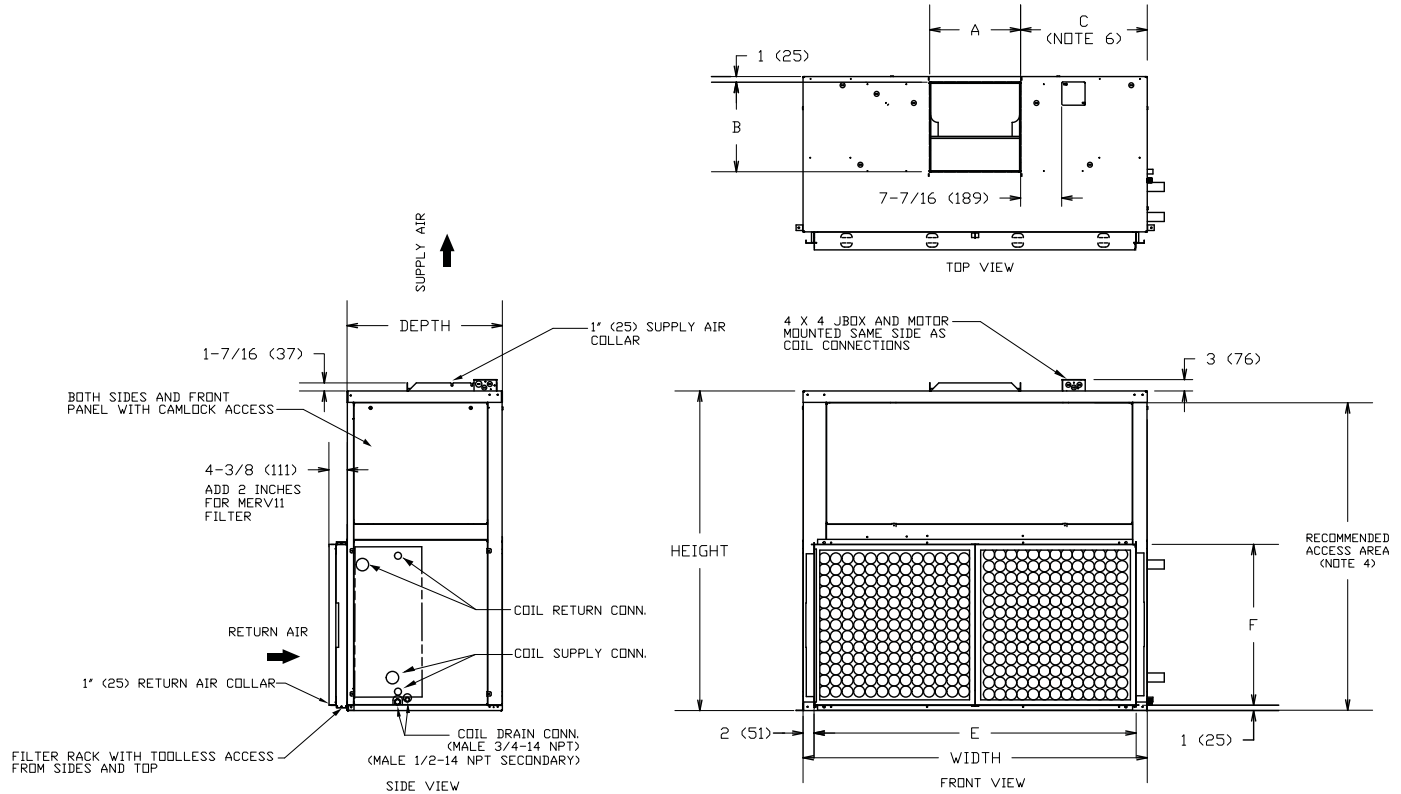

Size	Fan Size	Depth	Width	Height	Supply Duct			Return Duct	
					A	B	C	E	F
06	9x4	20 (508)	28 (711)	36-1/2 (927)	7-1/8 (181)	10-1/2 (267)	16-3/4 (425)	24 (610)	16-1/2 (419)
08	9x6	20 (508)	28 (711)	36-1/2 (927)	8-1/2 (216)	10-1/2 (267)	15-1/4 (387)	24 (610)	16-1/2 (419)
10	10x4	22 (559)	37 (940)	39-3/8 (1000)	7-1/8 (181)	11-9/16 (294)	24-1/2 (622)	33 (838)	18-1/4 (464)
12	10x7	22 (559)	37 (940)	39-3/8 (1000)	9-15/16 (252)	11-9/16 (294)	21-1/2 (546)	33 (838)	18-1/4 (464)
16	11x10	22 (559)	47 (1194)	39-3/8 (1000)	13-3/8 (340)	12-3/4 (324)	16-3/4 (425)	43 (1092)	18-1/4 (464)
20	12x9	24 (610)	48 (1219)	45-1/8 (1146)	12-1/2 (318)	13-3/4 (349)	17-3/4 (451)	44 (1118)	20-3/4 (527)
30	12x12	28 (711)	48 (1219)	54-3/16 (1376)	15-7/8 (403)	13-3/4 (349)	16 (406)	44 (1118)	29 (737)
40	15x12	28 (711)	62 (1575)	57-5/8 (1464)	16-7/16 (418)	16-1/16 (408)	22-3/4 (578)	58 (1473)	29 (737)

- NOTES:
1. Right hand shown, Left hand opposite.
  2. All dimensions are +/- 1/4" (+/- 6 mm)
  3. Drain pan removal is on the piping side of the unit.
  4. Allow adequate spacing or maneuverability of unit to allow service through recommended access area.
  5. Dimensions in parenthesis are in millimeters.
  6. "C" dimension is measured from coil side of unit.
  7. Product specifications are subject to change without notice.

Drawing is provided for reference only.  
Dimensions may vary with options ordered.  
Consult IEC website for submittal drawings.

### Physical Data, Cont'd.

#### VBA Unit with Optional Electric Heat

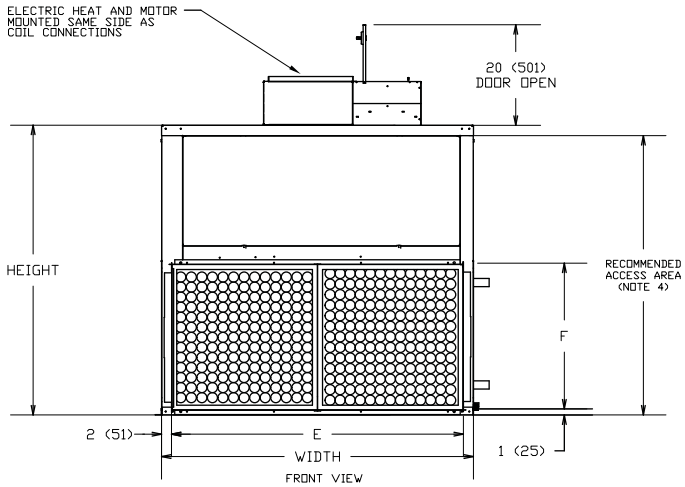
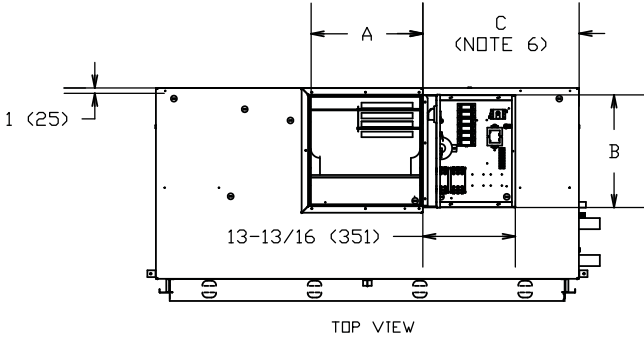

Size	Supply Duct Dimensions – Inches (Millimeters)		
	A	B	C
06	8-7/8 (225)	10-7/8 (276)	16-3/4 (425)
08	8-7/8 (225)	10-7/8 (276)	15-1/4 (387)
10	10-3/8 (264)	12 (305)	24-1/2 (622)
12	10-3/8 (264)	12 (305)	21-1/2 (546)
16	13-7/8 (352)	13 (330)	16-3/4 (425)
20	13 (330)	14-1/8 (359)	17-3/4 (451)
30	16-1/4 (413)	14-1/8 (359)	16 (406)
40	16-3/4 (425)	16-3/8 (416)	22-3/4 (578)

#### VBA Unit with Optional Motor Controls

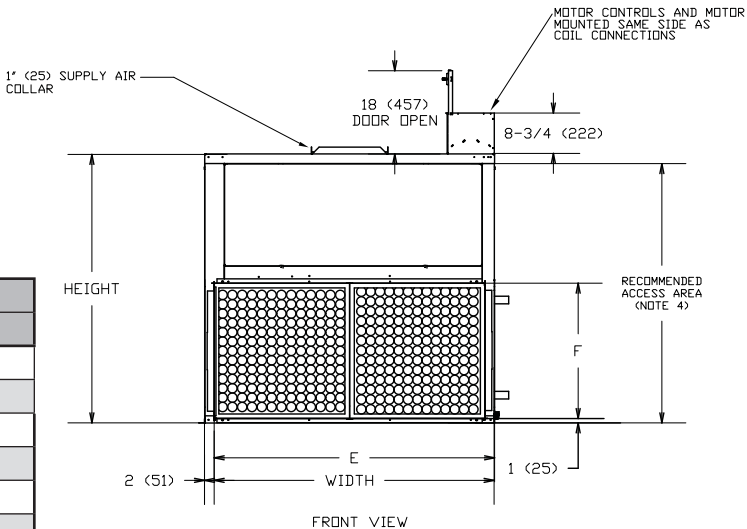
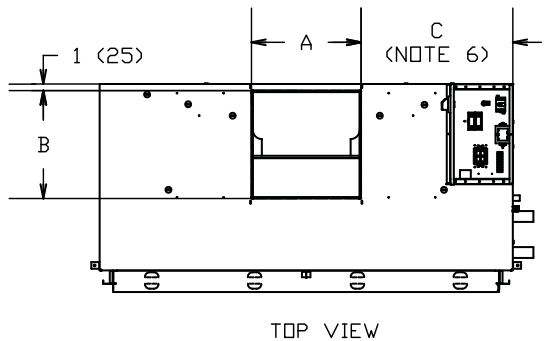

Size	Supply Duct Dimensions – Inches (Millimeters)		
	A	B	C
06	7-1/8 (181)	10-1/2 (267)	16-3/4 (425)
08	8-1/2 (216)	10-1/2 (267)	15-1/4 (387)
10	7-1/2 (191)	11-9/16 (294)	24-1/2 (622)
12	9-15/16 (252)	11-9/16 (294)	21-1/2 (546)
16	13-3/8 (340)	12-3/4 (324)	16-3/4 (425)
20	12-1/2 (216)	13-3/4 (349)	17-3/4 (451)
30	15-7/8 (403)	13-3/4 (349)	16 (406)
40	16-7/16 (418)	16-1/16 (408)	22-3/4 (578)

### Physical Data Stub-Out Location

#### Piping Connection Location (Centerline to Centerline) – Hydronic Cooling and Heating Coils

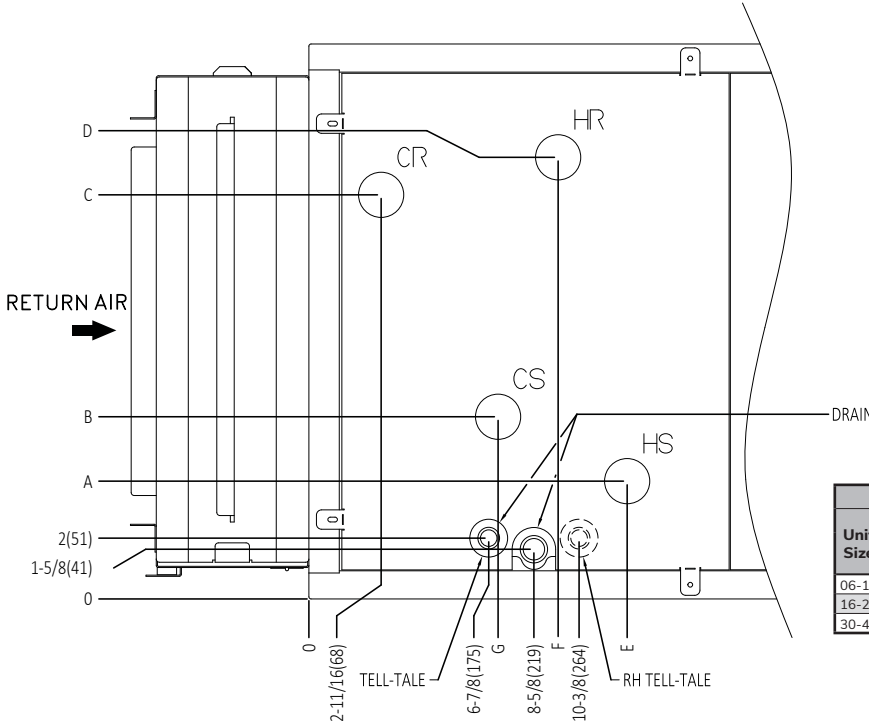

CR - Cold Water Return  
 HR - Hot Water Return  
 CS - Cold Water Supply  
 HS - Hot Water Supply  
 RH - Right Hand  
 LH - Left Hand

Horizontal, left hand unit with re-heat coil shown.

Unit Size	Coil Header Connection Size									
	8 Row		6 Row		4 Row		2 Row HW		1 Row HW	
	Nom. Size	Actual OD	Nom. Size	Actual OD	Nom. Size	Actual OD	Nom. Size	Actual OD	Nom. Size	Actual OD
06-12	1	1.125	3/4	0.875	3/4	0.875	1/2	0.625	1/2	0.625
16-20	1	1.125	1	1.125	1	1.125	1	1.125	1/2	0.625
30-40	1-1/2	1.625	1-1/2	1.625	1-1/2	1.625	1-1/2	1.625	1-1/2	1.625

Unit Size	Coil Rows		A	B	C	D	E	F	G	
	Cool	Heat								
06/08	4	-	-	6-1/8	12-3/4	-	-	-	5-15/16	
		1	3-1/2			15-1/2	7	7		
		2	3-13/16			15-13/16	7-9/16	7-9/16		
	6	-	-	7-3/4	14-3/8	-	-	-	8-1/8	
		1	3-1/2			15-1/2	9-3/16	9-3/16		
		2	3-13/16			15-13/16	9-3/4	9-3/4		
10/12	4	-	-	7-3/4	15-5/8	-	-	-	5-15/16	
		1	5-1/8			17-1/8	7	7		
		2	5-7/16			17-7/16	7-9/16	7-9/16		
	6	-	-	7-3/4	15-5/8	-	-	-	8-1/8	
		1	5-1/8			17-1/8	9-3/16	9-3/16		
		2	5-27/61			17-7/16	9-3/4	9-3/4		
16	4	-	-	7-3/4	16-3/8	-	-	-	5-15/16	
		1	LH 10-5/8 RH 13-3/8			12	9-5/8	7		
		2	12			13-5/8	10-3/8	7-9/16		
	6	-	-	7-3/4	15-5/8	-	-	-	8-1/8	
		1	LH 10-5/8 RH 13-3/8			12	11-13/16	9-3/16		
		2	12			13-5/8	12-1/2	9-3/4		
20	4	-	-	7-3/4	18-3/16	-	-	-	10-1/4	
		1	LH 11-15/16 RH 14-11/16			7-13/16	13-5/16	9-5/8		7
		2	11-9/16			7-7/8	15-13/16	9-1/16		-
	6	-	-	7-3/4	15-5/8	-	-	-	8-1/8	
		1	LH 11-15/16 RH 14-11/16			7-13/16	13-5/16	11-13/16		9-3/16
		2	11-9/16			7-7/8	15-13/16	11-1/4		-
30/40	4	-	-	5-15/16	26-5/16	-	-	-	10-1/4	
		1	7-1/16			25-13/16	9	7		
		2	10-5/16			7-13/16	23-13/16	9-1/8		-
	6	-	-	7-3/4	15-5/8	-	-	-	8-1/8	
		1	7-1/16			25-13/16	11-1/8	9-1/8		7-1/16
		2	10-5/16			7-13/16	23-13/16	11-5/16		-

**Physical Data Stub-Out Location, Cont'd.**

**Piping Connection Location (Centerline to Centerline) – R-410A Cooling with Hot Water Heating**

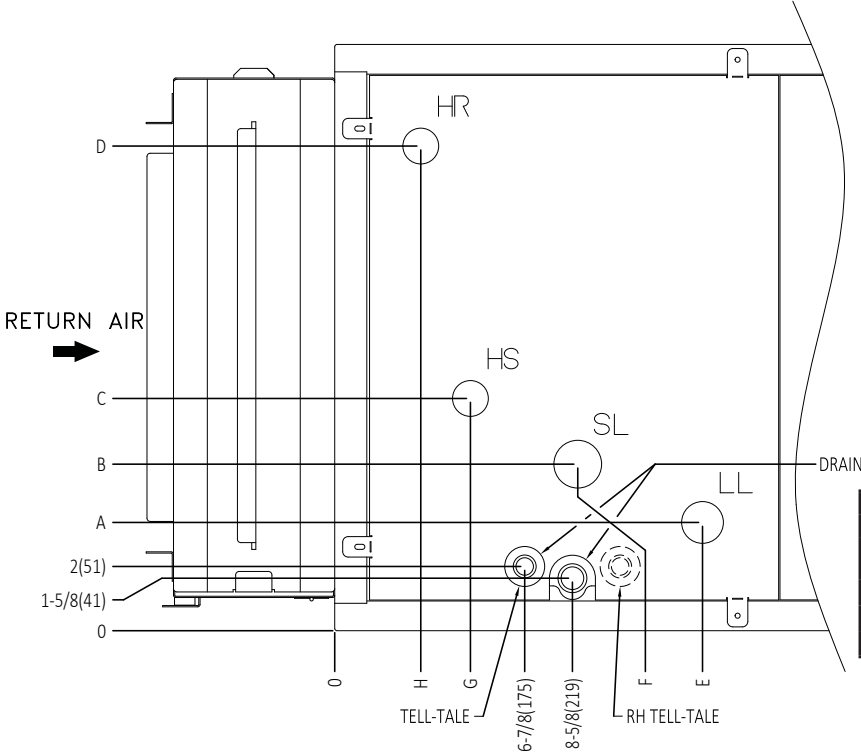

HR - Hot Water Return  
 HS - Hot Water Supply  
 LL - Liquid Line  
 SL - Suction Line

**Horizontal, left hand unit with pre-heat coil shown.**

Unit Size	Coil Header Connection Size (Nominal OD in Inches)							
	LL		SL		2 Row HW		1 Row HW	
	Nom. Size	Actual OD	Nom. Size	Actual OD	Nom. Size	Actual OD	Nom. Size	Actual OD
06-12	1/4	0.375	3/4	0.875	1/2	0.625	1/2	0.625
16-20	1/4	0.375	1	1.125	1	1.125	1/2	0.625
30-40	1/2	0.625	1-1/2	1.625	1-1/2	1.625	1-1/2	1.625

SIZE	COIL ROWS		A	B	C	D	E	F	G	H
	DX ONLY	WATER PRE-HEAT								
06/08	4	-	4-3/4	5-1/2	6	18	12-1/2	2-3/4	-	-
	6	1						3-3/4	2-5/8	2-5/8
	4	2						4-7/8	3-1/4	3-1/4
	6	-						-	-	-
10/12	4	-	6-1/2	7-1/8	5-1/8	17-1/8	12-1/2	2-3/4	-	-
	6	1						3-3/4	2-5/8	2-5/8
	4	2						4-7/8	3-1/4	3-1/4
	6	-						-	-	-
16	4	-	6-1/2	7-1/8	5-1/8	17-1/8	12-1/2	2-3/4	-	-
	6	1						3-3/4	2-5/8	2-5/8
	4	2						6-6/8	4-1/8	2-5/8
	6	-						-	-	-
20	4	-	6-1/2	7-1/8	5-1/4	19-3/4	12-1/2	2-3/4	-	-
	6	1						3-3/4	2-5/8	2-5/8
	4	2						6-3/4	4-1/4	2-5/8
	6	-						-	-	-
30/40	4	-	4-5/8	5-3/8	-	-	12-1/2	2-3/4	-	-
	6	1						6-1/8	-	-
	4	2						4-1/2	2-5/8	-
	6	-						-	-	-

### Distributed Weight Calculations

The following operating weight information is based on 8-row water-filled coils and double wall cabinet construction. For different coil and cabinet options, use the weight correction factor table.

#### Horizontal Units (Top View)

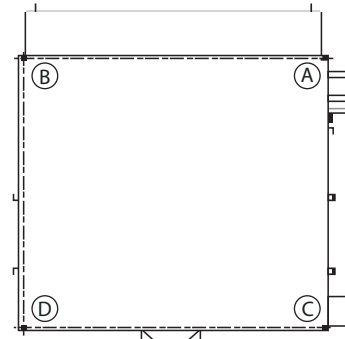
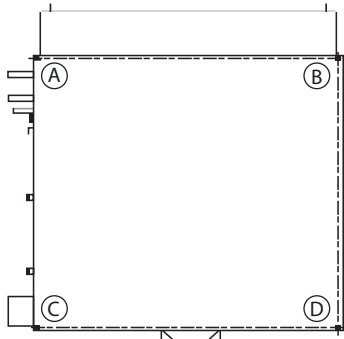

HBD Unit	No Electric Heat (lb)					With Electric Heat (lb)				
	A	B	C	D	Total	A	B	C	D	Total
06	58	63	55	59	235	58	66	67	75	266
08	59	64	55	59	237	58	67	67	76	268
10	73	81	65	73	292	72	86	78	91	327
12	74	82	66	74	296	73	86	78	92	329
16	92	99	81	88	360	91	103	94	107	395
20	105	113	89	97	404	105	117	103	115	440
30	135	144	109	117	505	135	148	123	136	542
40	176	183	135	143	637	176	187	150	161	674

#### Vertical Units (Top View)

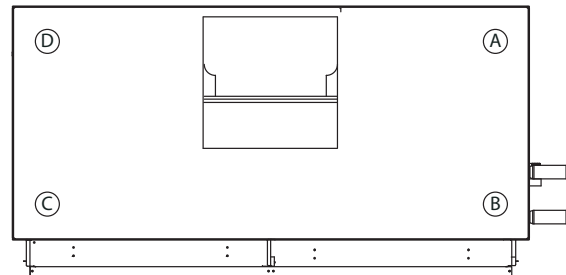
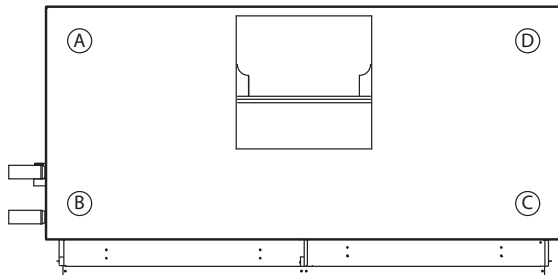

VBA Unit	No Electric Heat (lb)					With Electric Heat (lb)				
	A	B	C	D	Total	A	B	C	D	Total
06	60	62	59	51	232	66	73	69	55	263
08	61	63	59	51	234	66	74	70	55	265
10	73	79	71	60	283	79	91	82	64	316
12	74	80	72	61	287	80	92	83	65	320
16	86	97	84	70	337	92	110	96	73	371
20	105	123	101	83	412	110	138	114	86	448
30	127	156	123	98	504	132	172	137	100	541
40	152	193	146	115	606	156	211	161	116	644

## Filters

### Total Weight Unit Correction Factor (lb) – HBD/VBA

The weights on the previous page are for 8-row water-filled coils and double wall construction. For a different number of rows, total unit weight can be determined by:

Total unit weight can be adjusted by:

- a. Identify the size of unit and number of rows
- b. From the previous table, identify the total weight of the unit
- c. From the table below, identify the correction factor and deduct this factor from the total weight

Options	6	8	10	12	16	20	30	40
4-Row Coil	-21	-21	-28	-28	-39	-46	-74	-98
5-Row Coil	-16	-16	-21	-21	-29	-35	-55	-74
6-Row Coil	-11	-11	-14	-14	-20	-23	-37	-49
7-Row Coil	-5	-5	-7	-7	-10	-12	-18	-25
Single Wall Construction	-31	-31	-40	-40	-47	-58	-67	-82

NOTES: 1. Unit weights (shown in pounds), +/- 10%, are based on the largest water-filled coil and a 1 HP motor.

### Filters

The Belt Drive cabinet model unit has a 2" non-woven synthetic pleated filter furnished as standard equipment.

Unit Size	Filter Quantity	Nominal Filter Sizes – Inches (Millimeters)
		HBD/VBA
06	1	16-1/2" x 24" (419 x 610)
08	1	16-1/2" x 24" (419 x 610)
10	1	18-1/4" x 33" (464 x 838)
12	1	18-1/4" x 33" (464 x 838)
16	2	18-1/4" x 21-1/2" (464 x 546)
20	2	20-1/2" x 22" (521 x 559)
30	2	29" x 22" (737 x 559)
40	2	29" x 29" (737 x 737)

### Standard Features and Options

	Standard	Factory Installed Option	Field Installed Option	Factory Special Quote
<b>Air Flow Arrangement</b>				
Rear Return/Front Supply (HBD)	X			
Front Return/Top Supply (VBA)	X			
<b>Coils</b>				
4-Row 2-Pipe	X			
6 or 8-Row 2-Pipe		X		
4/1 or 4/2-Row 4-Pipe (CW/HW)		X		
6/1 or 6/2-Row 4-Pipe (CW/HW)		X		
Hydronic Heating Coils in preheat position		X		X
4/1 or 4/2-Row 4-Pipe (CW/Steam)		X		X
6/1 or 6/2-Row 4-Pipe (CW/Steam)		X		X
<b>Connection</b>				
Right	X			
Left	X			
<b>Drain Pan</b>				
Removable, double sloped, stainless steel	X			
<b>Fin Material</b>				
Aluminum with Galvanized End Sheets	X			
Copper with Stainless End Sheets and Bottom Coil Baffle		X		X
Alternate fins per inch		X		X
<b>Electric Heat (1-40 KW, Controls, Stages)</b>		<b>X</b>		
<b>Indoor Air Quality</b>				
2 Sets of 1" Throwaway		X		
1" MERV 8 Pleated		X		
2" MERV 8 Pleated	X			
2" MERV 11 + 2" Pleated Prefilter		X		
4" MERV 11		X	X	
4" MERV 13		X	X	
Biopolar Ionization		X		
<b>Insulation</b>				
1" Standard Fiberglass	X			
1" Premium IAQ Fiberglass (not available with Double Wall)		X		
1" Foil Face (not available with Double Wall)		X		
1" Closed Cell		X		
<b>Cabinet Construction</b>				
18 gauge Single Wall	X			
Double Wall (with solid or perforated liner)		X		
Double Wall with antimicrobial treatment				X
Seismic Structural Upgrade (not available with Double Wall)		X		

table continued on next page



## Standard Features and Options, Cont'd.

	Standard	Factory Installed Option	Field Installed Option	Factory Special Quote
<b>Motor Type</b>				
ODP Single Speed, 1-Phase	X			
ODP Single Speed, 3-Phase	X			
Premium Efficiency Inverter Duty, 3-Phase		X		
<b>Motor Voltage</b>				
120-208-230-277/1/60	X			
208-230-460/3/60	X			
<b>Paint Options</b>				
Arctic White, Polar White, Flat Black, Ermine Gray, Champagne Beige, Toffee Brown		X		
Special Color				X
<b>Options</b>				
Mixing Box			X	
24V Damper Actuator for mixing box			X	X
24V Condensate Float Switch		X		
Low Temperature Limit Switch		X		X
Filter Change Indicator		X		X
Basic Motor Controls		X		
Deluxe Motor Controls		X		
Interlocking Disconnect Switch		X		

## Standard Features and Options, Cont'd.

### Factory Installed Options

#### Controls:

#### Motor Controls – Units with no electric heat

Standard units have the motors wired to the J box. Two optional controls schemes are available:

- Basic motor control (24 V) include the transformer, motor contactor and a terminal strip.
- Deluxe motor controls adds motor fusing and interlocking disconnect switch to the basic control package

Basic motor controls are recommended whenever valve packages are orders.

#### Electric Heat Controls

Electric heaters come standard with a transformer, heater and motor contactors, motor and electric heat fusing, and a terminal strip.

An optional interlocking disconnect switch is available.

#### Condensate Float Switch

A water-level sensing device designed to prevent drain pan overflow. The standard switch is wired normally closed. **Switches are available only in 24 V.** It is recommended at least basic motor control is ordered if this option is required.

### Field Installed Options

#### Mixing Boxes

Mixing boxes can be used when outside air is required. Mixing boxes come with base rails. Refer to the drawings on pages 42 and 43 for additional information.

**Standard Features and Options, Cont'd.**

**Bipolar Ionizer Specifications**

**SPECIFICATIONS:**

Airflow Capacity: ..... 2,400 CFM  
 Pressure Drop: ..... Less than 0.01 In. WG  
 Housing Material: ..... ABS  
 Weight: ..... 0.2 lbs.  
 Maximum Operating Temperature: ..... 200° F (93°C)  
**Electrical:**  
 Voltage: ..... 24V AC (602)  
 Power Consumption: ..... Less than 1 watt  
 Frequency: ..... 50/60 hertz  
 Over Current Protection:.. 500mA Glass Cartridge Fuse  
 Lead Wires ..... 50"(L)

**Ionization Output:**  
 Mode of Operation ..... Needlepoint Type  
 Needle Configuration: ..... Brush Type

**DIMENSIONS:** See Figure 1

**APPROVALS:** Intertek/ETL Standard UL 867

**Figure 1.**

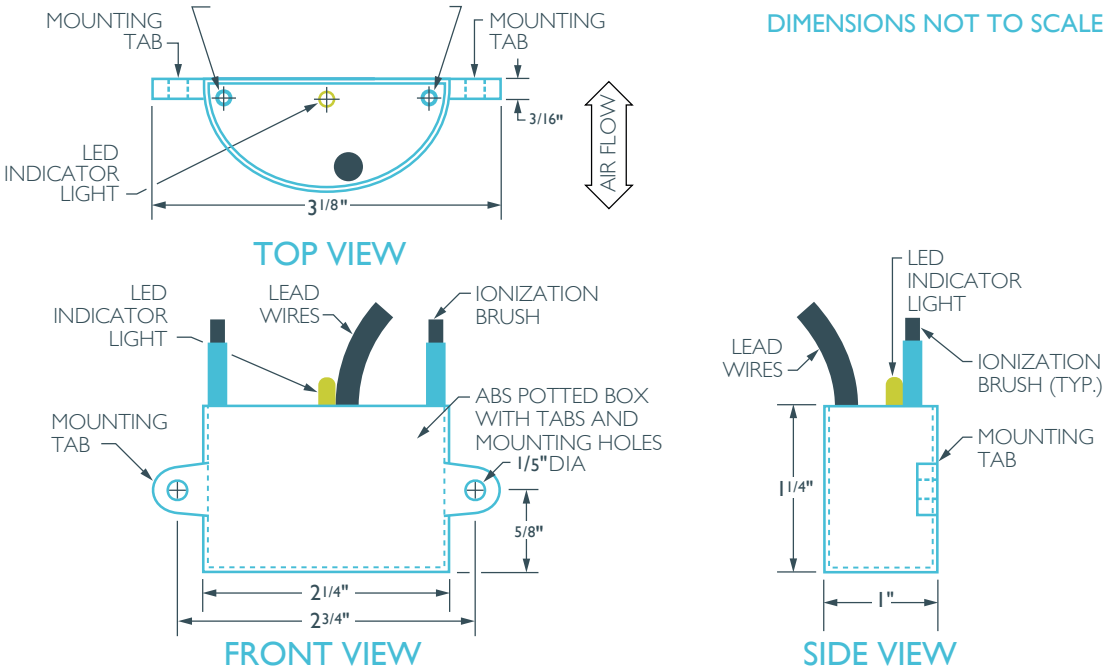

### Options – Mixing Box

#### Mixing Box with Base Rails

Mixing box option includes 1.) knockdown base rails for field assembly, and 2.) preassembled mixing box. Base rails are letter coded for ease of assembly and all hardware required for assembly is included. Linkage kit consists of 2 crank arms, 2 swivels, and either a 25" (sizes 06-16) or a 34" (sizes 20-40) length of 5/16" rod provided for field installation of actuator. Consult factory for the 24 V damper actuator option. Mixing box option adds 3" to the unit height due to the base rails.

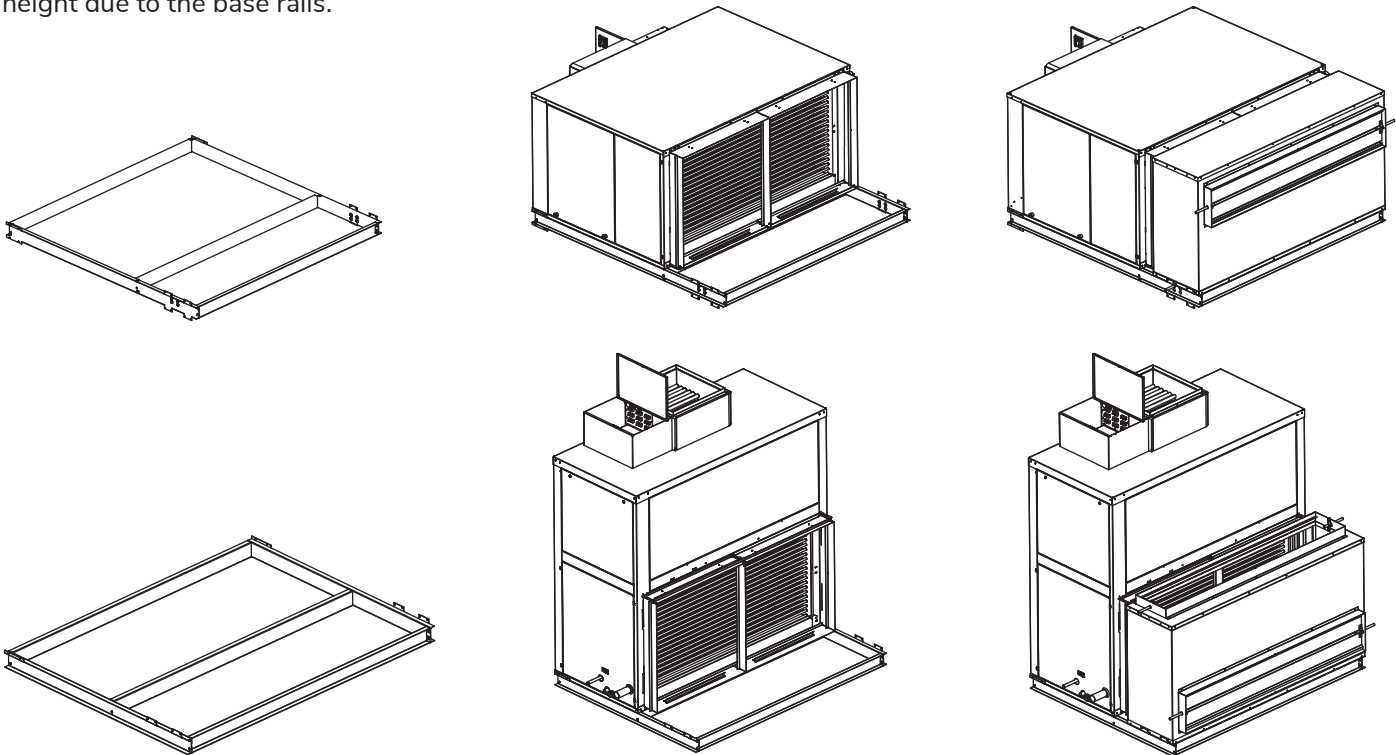

#### Base Rail Details

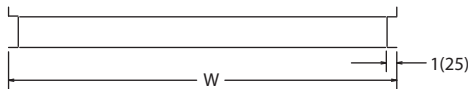

FRONT VIEW

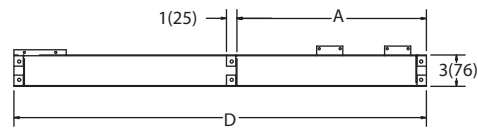

SIDE VIEW

Horizontal Units – Dimensions - Inches (Millimeters)			
Unit Type and Size	W	D	A
HBD06	28 (711)	51.6 (1311)	16.1 (409)
HBD08	28 (711)	51.6 (1311)	16.1 (409)
HBD10	37 (940)	55.2 (1402)	18.1 (460)
HBD12	37 (940)	55.2 (1402)	18.1 (460)
HBD16	47 (1194)	55.4 (1407)	18.1 (460)
HBD20	48 (1219)	57.8 (1468)	18.1 (460)
HBD30	48 (1219)	59.8 (1519)	20.1 (511)
HBD40	62 (1575)	63 (1600)	20.1 (511)

Vertical Units – Dimensions - Inches (Millimeters)			
Unit Type and Size	W	D	A
VBA06	28 (711)	35.5 (902)	16.1 (409)
VBA08	28 (711)	35.5 (902)	16.1 (409)
VBA10	37 (940)	39.5 (1003)	18.1 (460)
VBA12	37 (940)	39.5 (1003)	18.1 (460)
VBA16	47 (1194)	39.5 (1003)	18.1 (460)
VBA20	48 (1219)	41.5 (1054)	18.1 (460)
VBA30	48 (1219)	47.5 (1207)	20.1 (511)
VBA40	62 (1575)	47.5 (1207)	20.1 (511)

**Options – Mixing Box, Cont'd.**

**Mixing Box Details**

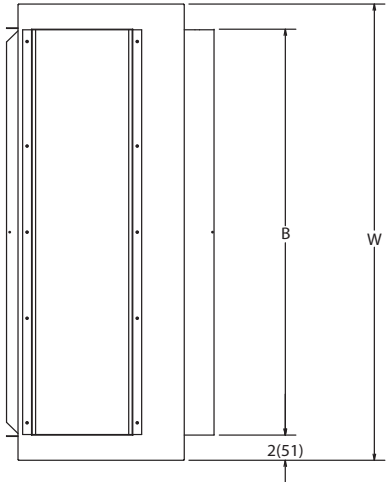
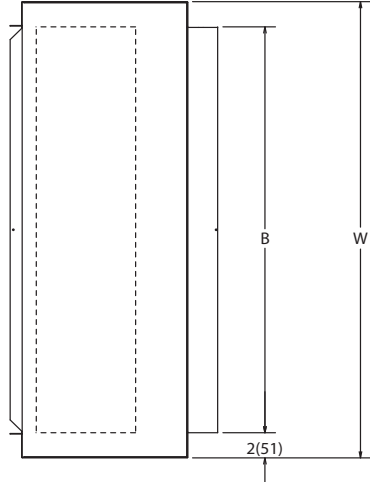

TOP VIEWS

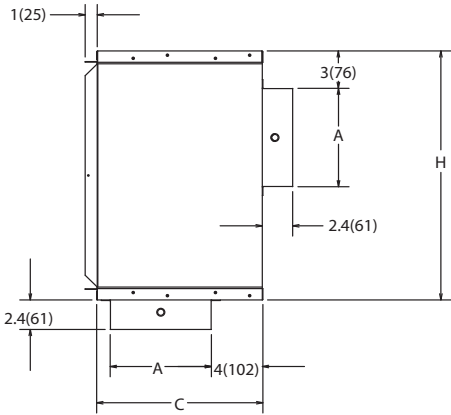

BTM/REAR INLET - HBD  
BTM/Front Inlet for - VBA

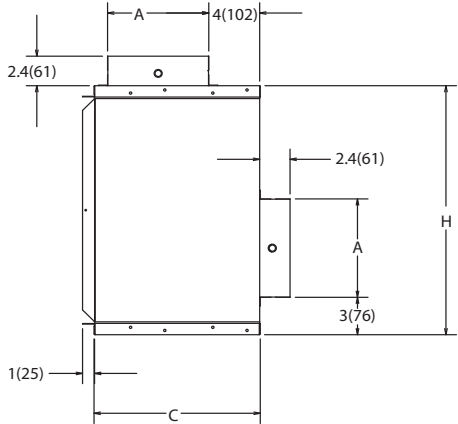

TOP/REAR INLET - HBD  
TOP/Front Inlet for - VBA

RIGHT HAND SIDE VIEWS

Dimensions - Inches (Millimeters)					
Unit Size	H	W	A	B	C
06	18.5 (470)	28 (711)	6 (152)	24 (610)	11 (279)
08	18.5 (470)	28 (711)	6 (152)	24 (610)	11 (279)
10	20.25 (514)	37 (940)	8 (203)	33 (838)	13 (330)
12	20.25 (514)	37 (940)	8 (203)	33 (838)	13 (330)
16	20.25 (514)	47 (1194)	8 (203)	43 (1092)	13 (330)
20	22.75 (578)	48 (1219)	8 (203)	44 (1118)	13 (330)
30	31 (787)	48 (1219)	10 (254)	44 (1118)	15 (381)
40	31 (787)	62 (1575)	10 (254)	58 (1473)	15 (381)

This page intentionally left blank.

This page intentionally left blank.

# Belt Drive Series

## FAN COIL TECHNICAL CATALOG



Contact your local IEC Sales Representative for further details and pricing applicable to this product. Visit our website ([iec-okc.com](http://iec-okc.com)) to find your local IEC Sales Rep.

IEC Part Number: I100-90002106  
CA-060 Revision 24.2 (01/2022)

©2000-2022 International Environmental Corporation (IEC)



5000 W. I-40 Service Rd.  
Oklahoma City, OK 73128  
P: 405.605.5000  
F: 405.605.5001  
[www.iec-okc.com](http://www.iec-okc.com)