



**Catalog 550-14**

## **Vision® Air Handler**

**Sizes 003—090**



Nomenclature and Certification . . . . .	3	Sound . . . . .	29
ARI Certification . . . . .	3	Air Supply Systems and Fan Laws . . . . .	30
IBC Certification (optional) . . . . .	3	Fan and Motor Heat . . . . .	31
Agency Listed . . . . .	3	Variable Air Volume . . . . .	32
The Vision Air Handler Advantage . . . . .	4	Variable Frequency Drives . . . . .	32
The Vision Air Handler Advantage . . . . .	4	Engineering and Physical Data . . . . .	33
Introduction . . . . .	6	Component and Section Weights . . . . .	45
Quality . . . . .	6	Fan Data . . . . .	47
Flexibility . . . . .	6	Coil Data . . . . .	49
Cabinet Construction . . . . .	6	Multi-zone Coils . . . . .	51
Seismic Design Considerations . . . . .	8	Side Load Filter Data . . . . .	52
Access and Serviceability . . . . .	8	Dimensional Data . . . . .	54
Daikin SelectTools Software Selection Program . . . . .	9	Coil Section . . . . .	68
Vision's Unique Standard Features . . . . .	10	Heating Coil Section . . . . .	70
Vision Customized Options . . . . .	12	Filter Section . . . . .	75
Component Types . . . . .	14	Economizer Section . . . . .	79
Fans . . . . .	14	Angled Economizer Section . . . . .	80
Coils . . . . .	17	Blenders . . . . .	81
Filters . . . . .	18	Access Doors . . . . .	82
Ultraviolet Light Options . . . . .	20	Diffuser . . . . .	83
Access . . . . .	20	Access Section . . . . .	84
Mixing Boxes and Economizers . . . . .	20	Internal/External Face and Bypass Sections . . . . .	85
Face and Bypass Dampers . . . . .	20	Discharge or Return Plenum . . . . .	86
Blenders/Air Mixers . . . . .	21	Sound Attenuator Section . . . . .	87
Attenuators . . . . .	21	Base Rail . . . . .	88
Digital Ready™ Air Handlers . . . . .	21	Electrical Data . . . . .	89
Starters and VFDs . . . . .	22	Supply Power Wiring . . . . .	89
Energy Recovery . . . . .	22	Engineering Guide Specification . . . . .	90
Electric Heaters . . . . .	24		
Air Handler Selection . . . . .	25		
Selecting Coils . . . . .	25		
Selecting Accessories . . . . .	25		
Selecting Fans . . . . .	25		
Quick Select Table . . . . .	26		
Application Considerations . . . . .	28		
Installation Flexibility . . . . .	28		
Mounting and Access . . . . .	28		
Ductwork . . . . .	28		
Piping and Drain Pan Traps . . . . .	29		
Vibration Isolation . . . . .	29		
Multi-zone Air Handler Applications . . . . .	29		

**Figure 1: Nomenclature**

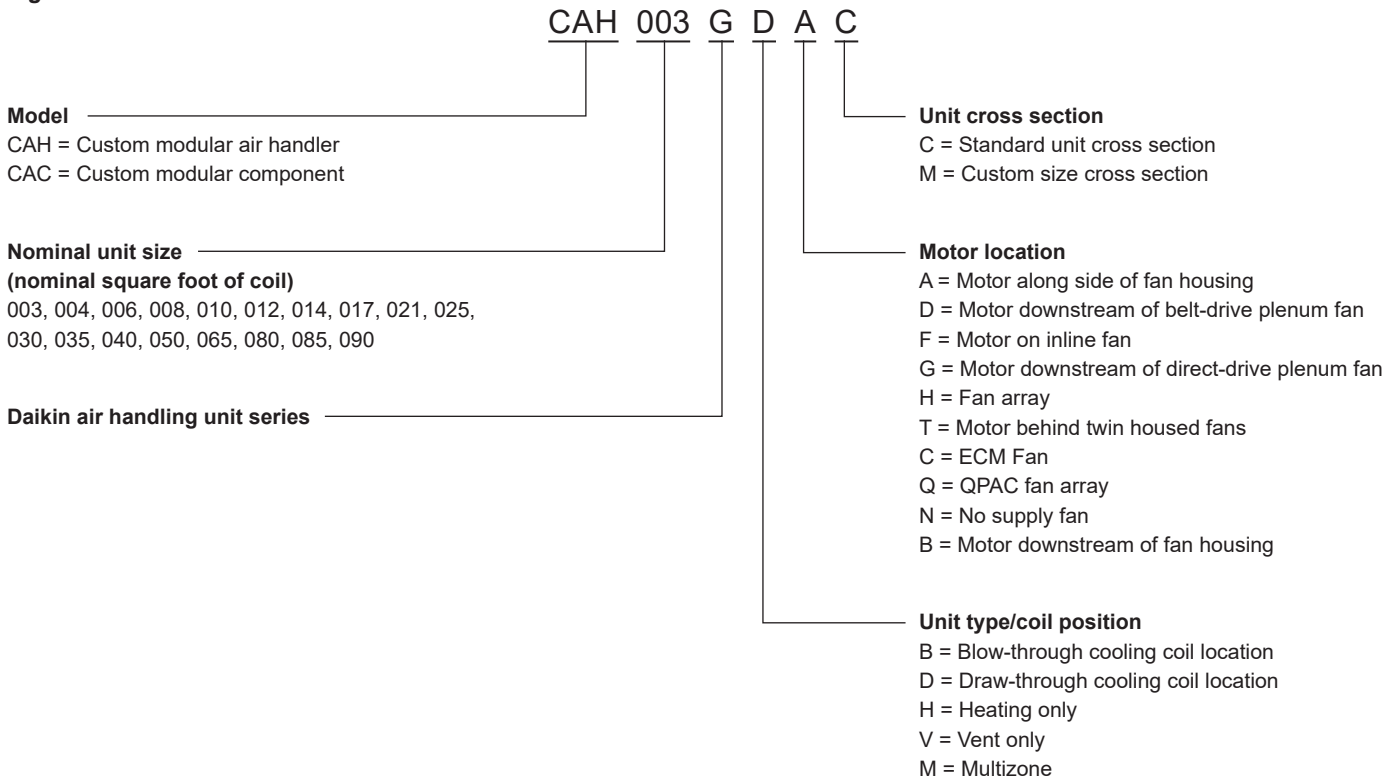

**ARI Certification**



Certified in accordance with the forced circulation air cooling and air heating coils certification program, which is based on AHRI Standard 410.



Standard and custom size units certified in accordance with the central station air handling units certification program, which is based on AHRI Standard 430.

Labeled Vision units are tested and listed by ETL in accordance with UL 1995, Standard for Safety Heating and Cooling Equipment, and thereby fully comply with NFPA 90A material requirements.

**IBC Certification (optional)**

Seismic certification per applicable buildings codes tested and analyzed in accordance with:

**IBCO AC156  
ASCE-7**

**IBC 2000, 2003,  
2009, 2012  
NFPA 5000**

**VMC Seismic Consulting Group: Serial Number 39928V**  
 Available upon request.

**OSHPD Pre-Approval (optional):  
OSP-0325-10**

**Agency Listed**



All standard units  
 All custom size units  
 All Canadian units

**MEA**  
 342-99-E

## The Vision Air Handler Advantage

<b>Flexibility</b>	
<b>Vision's unique design</b>	<b>What it can do for you</b>
Custom-modular platform	Allows customizing of the system with a wide selection of components and sizes.
Variable Dimensioning™ design	Allows cabinet to be sized in two-inch increments (height and width) to meet installation or aesthetic requirements.
Ships assembled or by section	Minimizes install time; reduces installation cost; and allows passage through doors, tight spaces, and in elevators (great for retrofit jobs).
Multiple coil, fan and filter selections	Allows optimum selections for cost, energy efficiency, performance, indoor air quality, and low noise.
Wide selection of base rail heights (4" to 12")	Allows for condensate trapping, eliminates need for costly housekeeping pad, and provides space required between condensate connection and traps on steam applications.
Painted cabinet	Enhances exterior appearance for units in visible locations.
<b>Indoor Air Quality</b>	
<b>Vision's unique design</b>	<b>What it can do for you</b>
<b>Low-leakage cabinet construction</b> <b>Standard Cabinet:</b> less than 0.5 CFM/ft <sup>2</sup> of cabinetry at design static up to +5/-6" w.c. <b>High Pressure Cabinet:</b> less than Class 6 leakage or 1% supply air volume at design static up to +/-8" w.c.	Minimizes air leakage, noise and unfiltered air.
Double sloped stainless steel drain pan	Inhibits bacterial growth; eliminates standing water that can support bacteria.
Double-wall, foam injected construction	Eliminates fiberglass fibers eroding into the air stream.
Multiple filter types (flat, angular, bag and cartridge) with side-load and front-load capabilities	Gives full range of filter efficiencies, final filter arrangements, and filter section depth flexibility.
Hinged access doors with full-grip handles	Allows for easy inspection and cleaning of drain pans; promotes regular inspections.
Patented splice collar	Prevents unfiltered, unconditioned air from entering the system. Allows for leak-resistant section to section joining in the field.
Easy-to-remove access panels	Allows for easy inspection and cleaning of drain pans; promotes regular inspections.



<b>Operating Efficiency</b>	
<b>Vision's unique design</b>	<b>What it can do for you</b>
The low air-leakage cabinet design, all inside and outside panel penetrations are sealed	Increases operating efficiency; reduces energy loss and operating costs.
Patented gasketed frame channels	Minimizes direct exposure of metal to metal in cabinet framework to reduce cold bridging and condensate collection; lowers operating costs.
Energy recovery (plate heat exchanger or energy recovery wheel)	Reduces cost of heating or cooling outside air; recovers up to 50% of the energy normally exhausted from a building.
Fan selection options (housed forward curve or airfoil, belt-drive or direct-drive plenum, inline, twin fans and ECM fan)	Results in lowest possible BHP requirements.
Patented UltraSeal™ low-leak dampers	Maximizes operating efficiency; reduces operating cost.
Double wall liners with injected foam insulation	R-13 insulation value reduces condensation and improves operating efficiency.
<b>Easy, Low Cost Installation</b>	
<b>Vision's unique design</b>	<b>What it can do for you</b>
Ships assembled or by section	Minimizes install time, reduces installation cost; allows passage through doors, tight spaces and in elevators (ideal for retrofit jobs).
Complete disassembly	Allows for complete knock down during installation if required for tight fit applications.
Patented section splicing	Saves installation time; creates an airtight environment.
Extended coil connections with gasketed airseal, external drains and vents	Eliminates need to remove panels for connection during installation; preserves air-tight environment; saves time and cost.
Bolted frame construction with removable panels	Provides complete accessibility to unit components.
Fan system factory tested and balanced	Saves time during installation and promotes proper operation.
Discharge or inlet plenum sections	Adapts easily to ductwork and provides a turning section for stacked components.
<b>Easy Maintenance and Serviceability</b>	
<b>Vision's unique design</b>	<b>What it can do for you</b>
Direct-drive plenum fans	No fan bearings, belts or drives to replace or maintain.
Removable cross-member frame channels	Allows for top or side coil removal without disrupting unit integrity.
Extended fan bearing lube lines	Makes lubricating fan system easier.
Extended coil drain connections	Reduces coil venting time; helps coil condensate drain completely.
Hinged access doors with full-grip handles	Allows for proper inspection.

## Quality

Daikin air handling equipment has been respected and regarded as high quality for nearly 60 years. Daikin has taken a major step in redefining the indoor air handler with the Vision air handler. Demands for improved indoor air quality, low sound, high operating efficiency and smaller mechanical rooms require a better product for today's air handler market. The Daikin Vision air handler is designed to meet or exceed these demands.

The key to providing such a high quality product is in the basic design. The Daikin Vision air handler's patented construction provides unequalled thermal efficiencies and low leak rates. In addition, Vision air handlers offer tremendous flexibility in sizing, component options, and unit arrangements to meet the indoor air quality, operating efficiency, sound and installation requirements for today's extensive commercial and custom markets.

## Flexibility

By virtue of its unique frame design, the Daikin Vision air handler offers tremendous flexibility. This flexibility is reflected in our unique Variable Dimensioning™ feature that allows units to be sized in two-inch increments (height and width) to fit the available space. Numerous section and component options, and the ability to arrange components in whatever arrangement is required, allow Vision air handlers to be customized to the requirements of each job, without expensive field modifications. Finally, Vision air handlers can be shipped as a completely assembled unit, in modules or by component sections for new or retrofit applications that require smaller sections for passage through the building.

## Cabinet Construction

Daikin Vision air handler cabinetry consists of a box-type frame channel—the backbone of the unit—and easy-to-remove panels or hinged access doors. The unique, patented frame channel design allows three identical pieces to be bolted together to form a corner of the unit. Channel material is G90 unpainted galvanized steel (optional—painted G60 galvanized steel) with neoprene gasketing on all flanges to minimize leakage. Gasketing is also factory applied at all contact surfaces between interior and exterior metal components to minimize thermal bridging. See [Figure 2](#).

Panels are secured to the unit with fasteners that can be easily removed to access the unit interior. The frame channel and panels are easily disassembled and reassembled, giving contractors tremendous flexibility in installing and servicing the units—even where space is limited—saving time and money. Patented splice joints ([Figure 3](#)) help guide sections together for a tight fit, saving additional time and money on installation.

**Figure 2: Patented Gasketed Frame Channel**

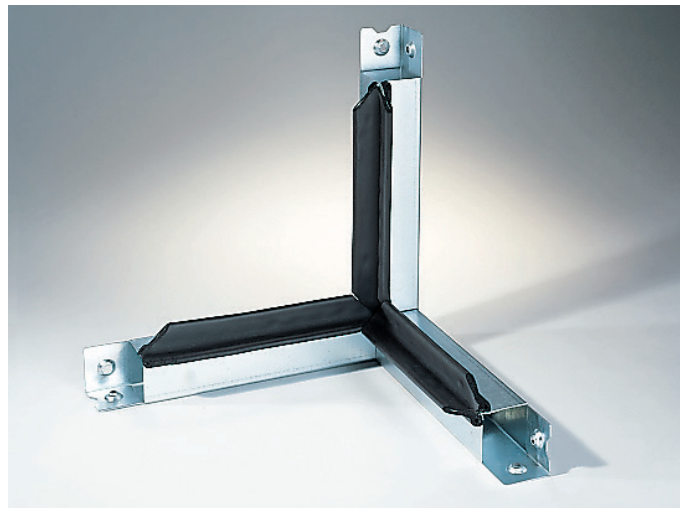

## Standard Cabinet

This unique cabinet design results in air tight, thermally efficient units, which translates into energy savings over the life of the unit. Vision air handlers are capable of casing leakage rates that shall not exceed 0.50 CFM per square foot of casing surface area a design static pressure up to a maximum of +5" w.c. in positive pressure sections and -6" w.c. in negative pressure sections.

## High Pressure Cabinet

The high pressure air handler construction utilizes laser welding technology to provide stronger frame channels and new gaskets to reduce the standard leakage rate to a casing leakage rate that shall not exceed ASHRAE 111 Class 6 or be no more than 1% of the supply air volume at design static pressure up to a maximum of +8" w.c. in positive pressure sections and -8" w.c. in negative pressure sections, where casing leakage (CFM/100 ft<sup>2</sup> of casing surface area) =  $C_L \times P^{0.65}$ . The high pressure air handler construction maintains the unique flexibility, ease of installation and serviceability that Vision has had for years while providing best-in-class air sealing.

ASHRAE 111 is the test standard to test duct leakage. The standard uses a class system to indicate relative leakage rates. These class levels are dependent on static pressure and surface area. The formula for leak class is:

$$C_L = \frac{F}{P^{0.65}}$$

where  $F = \frac{\text{Leakage in CFM}}{100 \text{ ft}^2 \text{ Cabinet Surface Area}}$  and  $P = \text{Static pressure in inches w.c.}$

To prove this construction works, full unit factory witness testing will be available for purchase.

Vision air handler panels use the latest technology to provide the lowest deflection, lightest weight and most importantly, the most thermally efficient 2-inch thick panel system available. R-13 insulation quality injected-foam is thermally pressed between inner and outer liners yielding an extremely rigid panel. The inner liner comes standard with galvanized steel or optional stainless steel. The outer liner standard is galvanized steel with options of pre-painted, or pre-painted heavy-gauge, galvanized steel.

Base rails are provided as an option on unit sizes through 21 square feet and are standard on larger units. They are available to meet jobsite height requirements, ranging from 4" to 12" and can eliminate the need for a housekeeping pad—saving time and money on installation. A full perimeter base rail per shipping section is factory assembled.

**Figure 3: Patented Splice Joint for Section-to-Section Joining**



## Seismic Design Considerations

Strict design, testing, and certification requirements for heating, ventilating, and air-conditioning equipment are clearly defined in the International Building Code, versions 2000 and 2003, for designated structures in earthquake-prone locations.

The goals of these requirements are to maintain systems to protect the public from hazard and maintain essential public services immediately after an earthquake. With the widespread adoption of the IBC throughout the U.S., it is important to understand its requirements and their impact on your specific building, and where you can turn for equipment to satisfy those requirements. Tested and certified compliant with the seismic provisions of the IBC, Daikin Vision and Skyline air handlers also comply with the construction requirements of NFPA 5000.

For use by the building official and design professional, the IBC has defined Seismic Use Group designations based on building use along with specific criteria for determining the Seismic Design Category of the building and the applicability of seismic design criteria to the building's mechanical equipment. Provide this information to your local Daikin Sales Representative so the proper modifications can be made to the air handler and have a compliance label affixed to the product so all IBC requirements in this regard are complied with. For additional information, Daikin has several published articles explaining in detail IBC seismic requirements. Go to [www.DaikinApplied.com](http://www.DaikinApplied.com) or contact your local Daikin sales representative to obtain these articles.

Daikin also has construction pre-certified for California's strict Office of Statewide Health Planning & Development (OSHPD) requirements. The OSP pre-approval shows that Daikin has already completed testing to allow engineers to specify, contractors to install, and owners to operate equipment that will still work after a seismic event.

## Access and Serviceability

Equipment must be designed to perform efficiently and withstand the wear and tear of everyday use. It must be designed to provide easy access to interior components for routine maintenance and service to maintain peak performance. The patented frame channels and easy-to-remove panels or hinged access doors of the Vision air handler cabinet provide complete access to the unit interior and components. Components, including the fan and coil assembly, can be removed through the side of the unit, top of the unit, or a combination of both, which reduces required service clearances ([Figure 4](#) and [Figure 5](#)). Coil removal on unstacked coils does not require access to the non-connection end of the coil. A unique coil tie down method simplifies coil removal and replacement.

**Figure 4: Top and Side Panel, Frame Channel Removal for Component Replacement**

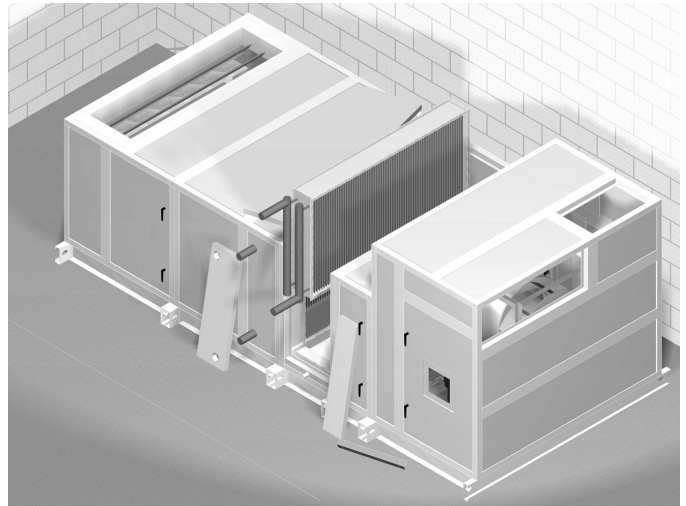

**Figure 5: Easy Access for Maintenance and Service**



## Daikin SelectTools Software Selection Program

Because the Daikin Vision air handler is so flexible and has so many different component types, there virtually are an infinite number of possible unit arrangements. To help the customer easily define their product requirements, Daikin provides a user-friendly software selection program, called Daikin SelectTools. This program configures and sizes both standard and custom units. Components can be selected in minutes. This Windows® based program leads the user through the selection process by prompting for pertinent input data for all components required. Component sections are selected by placing them on a configuration screen.

Once the unit layout is defined, the options and accessories are identified. The program gives immediate feedback regarding fan and coil selection, offering a choice of many different options based on the performance inputs. Once final component selections have been made, the program provides all output needed for specification and submittal purposes, including fan curves, coil performance psychometric charts, weights, dimensional drawings, and a unit specification. A fully detailed DXF file is also available. Daikin SelectTools is a comprehensive, efficient and user-friendly software selection program.



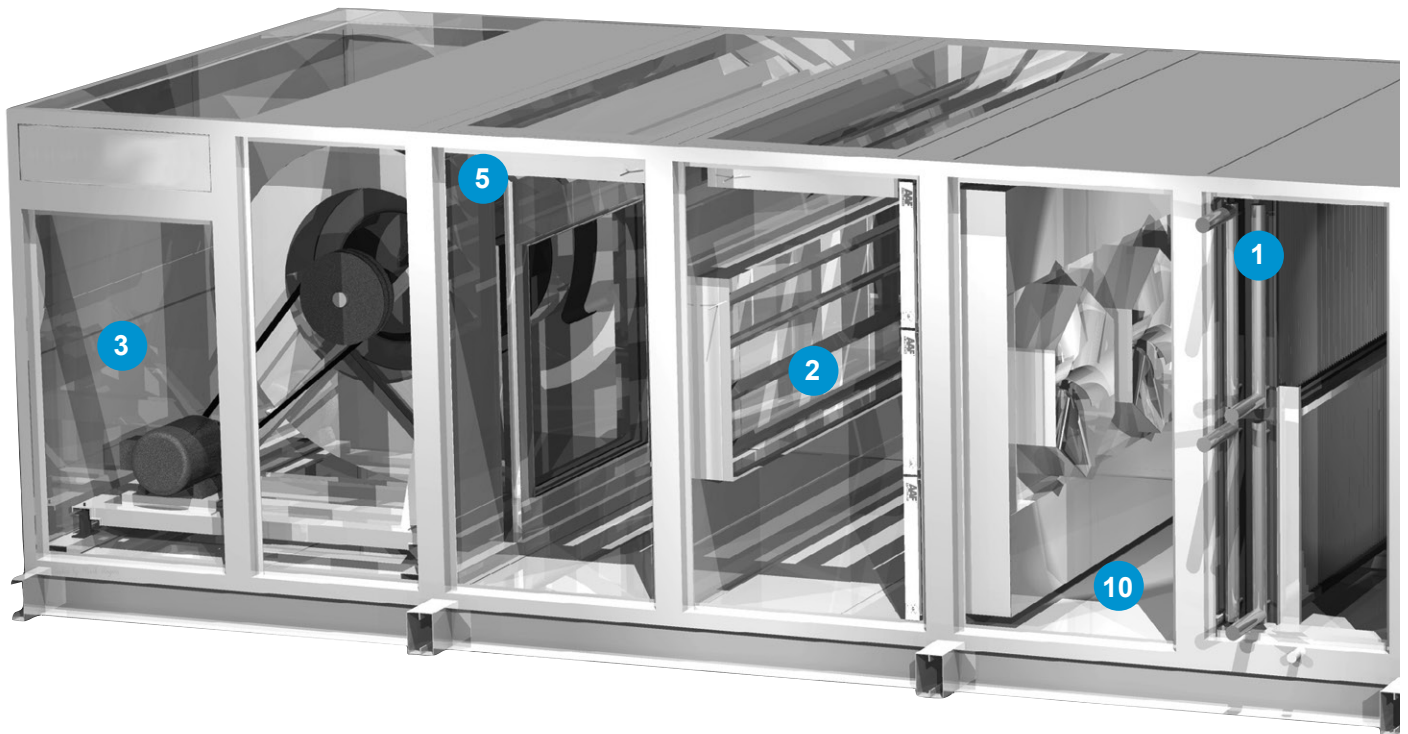

**1 Extended Coil Connections**

- Reduces installation costs
- Grommet seal reduces leakage
- Reduces maintenance time



**2 Patented UltraSeal™ Low-Leak Dampers**

- Aids proper drainage
- Help maximize operating efficiency
- Reduces operating cost



**3 Rugged Cabinet Enclosure**

- Rigid, thermal efficient (R-13) injected-foam panels are strong and lightweight
- Promotes longer unit life

**4 Smooth Interior Surface**

- Reduces dirt accumulation
- Facilitates cleaning
- Helps improve IAQ



**5 Gasketed Frame Channel**

- Eliminates metal-to-metal contact between paneling and framework
- Minimizes cabinet condensate and corrosion
- Facilitates top and side component removal
- Promotes long life

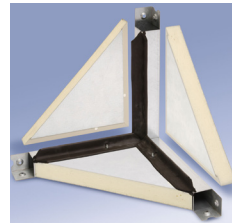

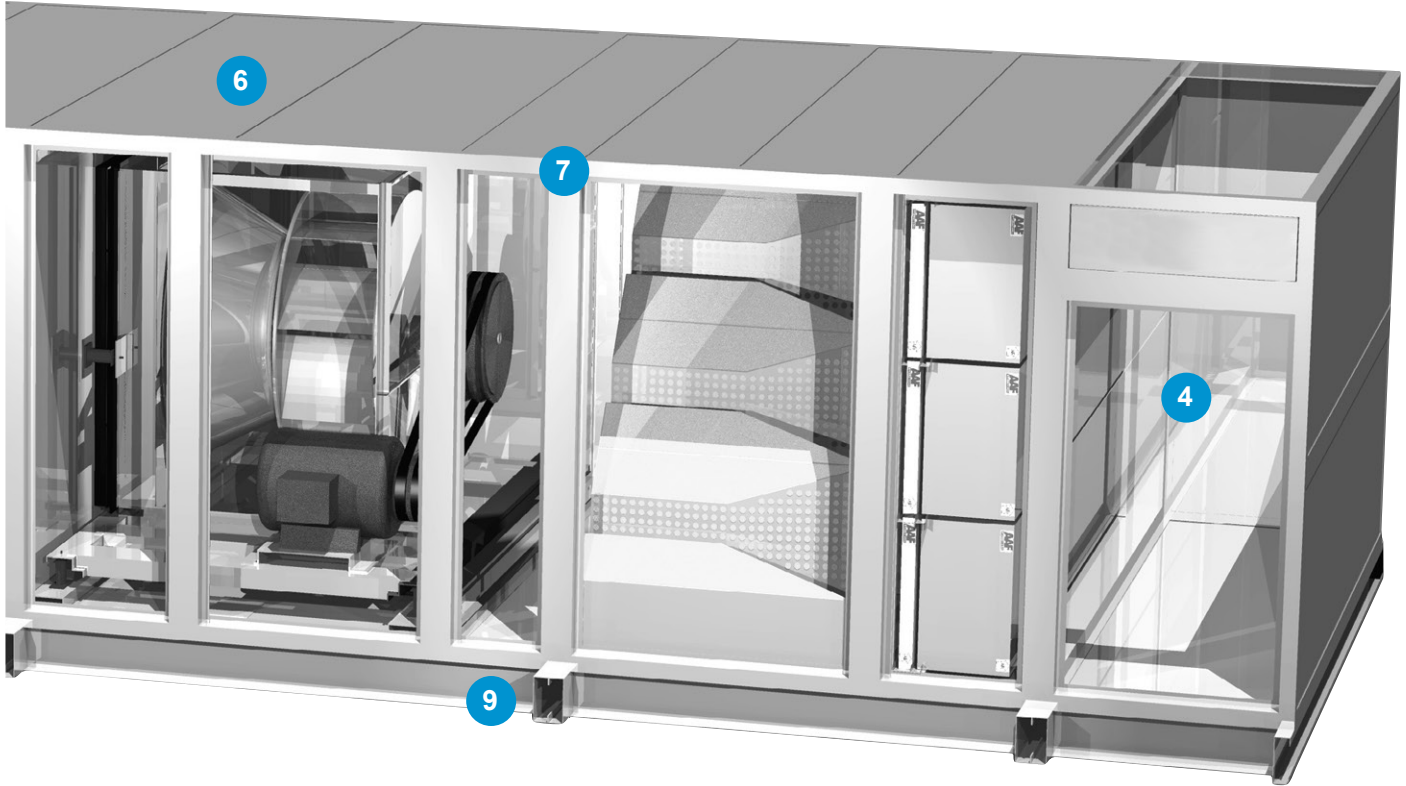

**6 Custom-Modular design**

- Allows custom selection and configuration of components
- Allows design of system to meet space and performance requirements

**7 Patented Splice Collar**

- Reduces installation cost
- Creates an airtight environment



**8 Frame Channel Disassembly**

- Allows two-sided access.
- Easier, faster service and maintenance

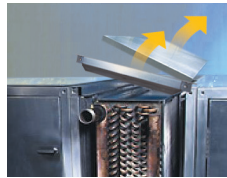

**9 Variable Height Base Rails (4" to 12")**

- Eliminates costly housekeeping pad
- Allows for condensate trapping

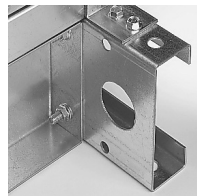

**10 Visible Double-Sloped Drain Pan**

- Makes inspection and cleaning easier
- Helps improve IAQ



**Use Daikin Vision product platform to build the ideal air handler for your specific application. Customized options include:**

- Variable Dimensioning™ feature for flexible cabinet sizing on 2" increments (height and width)
- Galvanized or painted cabinet
- Multiple section depths
- Variable base rail heights (4" to 12")
- Various casing and drain pan materials
- Mixing boxes/economizers
- Sound attenuators
- Integral face and bypass dampers
- Blenders and air mixers
- Multiple coil section depths
- Energy recovery sections (heat wheels, fixed plate heat exchangers, and runaround coil loops)
- Multiple blower options including housed airfoil, belt- or direct-drive plenum, dual plenum and fan array
- Filters (flat, angular, bag and cartridge) available in side load and/or front-loading configuration
- HEPA filters in final filter location
- Gas-phase filtration
- Flush-mounted filter gauges
- Starters and inverters (VFDs)
- Disconnect switches
- Electric heaters
- Ultra-violet lights
- Inward opening doors
- Windows, doors, marine lights and receptacles
- Manual selections to accommodate special components
- Flexibility in shipping arrangements
- Digital Ready™ control components
- Humidifier manifold



**Fan Options**



**Filter Options**

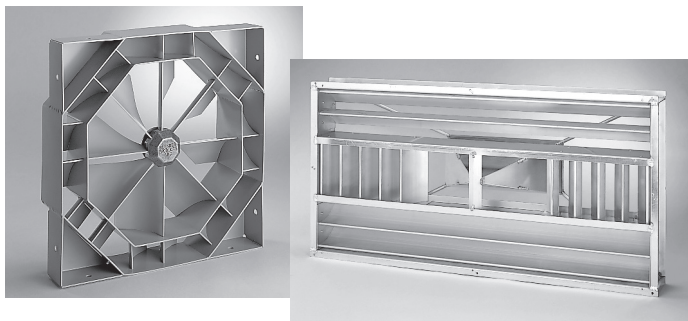

**Blender/Air Mixer Options**



**Filter Gauges**

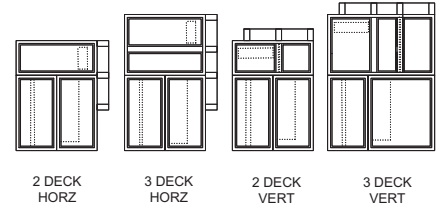

RETURN/ EXHAUST	ECONOMIZER	BLENDER	FILTER	ENERGY RECOVERY	F & BP DAMPER	COIL	ACCESS	HORIZONTAL COIL	SUPPLY FAN	DIFFUSER	COIL BLOW THRU	ACCESS	FILTER	ATTENUATOR PLENUM
PLENUM FAN	FC, AF FAN & TWIN FAN	2" & 4" ANGULAR	WHEEL	INTERNAL	HORIZ HEATING	LARGE	CLG. / HTG. COMBINATION	FC, AF FAN, & TWIN FAN		HORIZ		CARTRIDGE		DISCHARGE PLENUM
	INLET PLENUM	2" & 4" FLAT	FLAT PLATE CUBE	INTEGRAL	1 & 2 ROW STEAM AND 1-4 ROW WATER	MEDIUM	CLG. 10 ROW	PLENUM FAN		CLG. OR HTG.		BAG		
	ESI FAN	CARTRIDGE	EXTERNAL			SMALL	4 ROW	ESI FAN	<b>MULTI-ZONE COIL SECTIONS</b> 					
	MIXBOX WITH 4" FILTER	BAG	RIGHT ANGLE				SFA COIL MFA COIL F & BP							
	MIXING BOX							FAN AND VERTICAL COIL						
	MIXBOX WITH 2" FILTER													
	MIXBOX WITH ANG FILTER													



**Sensible and Enthalpy Flat Plate**



**Energy Recovery Equipment**



**Sound Attenuators**



**Marine Lights and Accessories**

## Fans

Fan types available with the Daikin Vision air handling units are housed double width, double inlet (DWDI) forward curved and airfoil fans, plenum fans, inline fans, twin fans and fan array. Forward curved fans generally provide the lowest first cost option and are used for lower static pressure applications.

### DWDI Housed Fans

Daikin housed forward curved fans will typically operate up to 6.0" of static pressure. Airfoil fans have a higher first cost, but are more efficient, quieter and can handle higher static pressures. Daikin housed airfoil fans will operate up to 9.0" of static pressure.

### Plenum Fans

Plenum fans (Figure 6) save space by eliminating turns in ductwork. They also provide a high degree of flexibility when locating the outlet ductwork. Plenum fans are also very good for blow-through applications as they generate a uniform outlet velocity profile. Both belt-drive and direct-drive plenum fans are available.

Direct-drive plenum fans offer easier maintenance as they do not have fan bearings, sheaves, or belts.

### Dual Fans

Direct-drive plenum fans come with the optional dual arrangement. The multi-fan sets will provide more even air flow and redundancy if one fan should need servicing.

For redundancy, the rule of thumb is that one fan will provide approximately 65% of the total CFM provided by both fans if the remaining fan is not sped up. If more redundancy is required, then a VFD and larger motor can be used to speed up the single fan to achieve more airflow. The selection software will calculate the redundancy. If a manual calculation is required to calculate the maximum available airflow from the single fan, manually plot the single fan performance onto the dual fan curve as in Figure 7. Extend the single fan rpm line to intersect with the system static pressure line. This balance point shows the performance of a single fan when one fails.

Figure 6: Plenum Fan



Table 1: Dual Fan Width Requirements

Direct-Drive Plenum Fan Size	Minimum Width (in.)	Minimum Standard Unit Size
11	64	010
12	64	010
15	68	014*
16	72	014*
18	80	017
20	88	030*
22	92	030*
24	100	035*
27	108	040
30	116	040
33	124	065
36	136	065
40	152	107 <sup>†</sup>
44	164	107 <sup>†</sup>

<sup>†</sup> Extended Cabinet  
\*Not on 4" width

If a VFD is used, the fan can be sped up to the limit of the HP of the motor to get more airflow. To increase redundancy, a larger motor can be selected. Remember that over sized fan motors may be less efficient. This typically occurs below 50- 60% design bhp. If you over size the motor to increase redundancy, as the motor BHP drops farther away from the actual HP, the motor will run less and less efficiently. So, if the application is meant for dual fans, it may be best to simply use the best selection for efficiency and utilize what redundancy comes with this selection. This will ensure the customer will have the most efficient operating setup while having the insurance of good redundancy.

The width of the fans will determine which cabinets will allow certain fans. Table 1 will help by showing what minimum cabinet width and unit size you will need for specific fan diameter selections.

An optional motor removal gantry system is available for the Dual Plenum Fan and Fan Array options. The gantry option provides easier serviceability of motors if access is not available on both sides of the fan section.

Figure 7: Dual Fan Redundancy – 65% if one fan fails

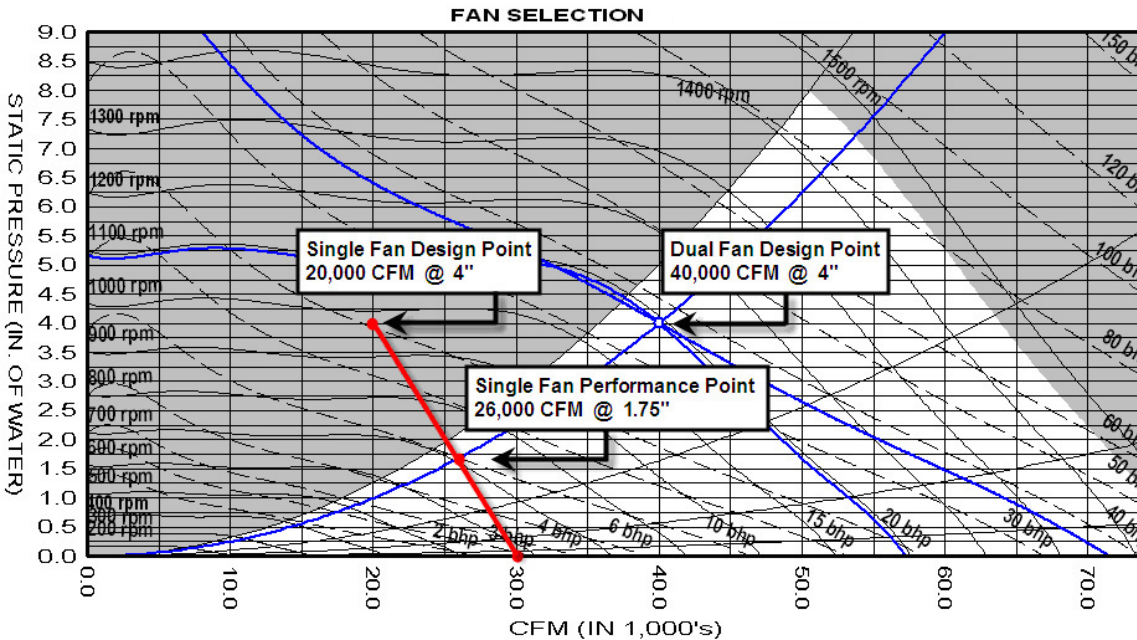

**Inline Fans**

Inline fans are quieter and more efficient than most standard fans. Inline fans are most beneficial in VAV applications. Twin fans (two housed forward curved fans mounted on one common shaft) are excellent in both retrofit units and stacked energy recovery units. Twin fans can handle high cfm in very low profile units.

The different types of fans are available in numerous wheel diameters per unit size. The fan size selection is always optimized and identified by the SelectTools software. The program considers performance, efficiency, sound generation and first cost and offers a number of fan sizes to select from. Fan and motor assemblies can be provided with 2" spring (Figure 8), rubber in shear, or rigid mount allowing the customer the option of isolating the fan and motor assembly internally or isolating the entire unit. All fans are dynamically balanced at the plant as an assembly, including the motors and drives. All belt-drive fans rotate on a solid steel shaft of uniform diameter that has been ground, polished, and coated with a rust inhibitor. Fan shafts are selected to have a maximum operating speed well below the first critical speed.

Belt guards are available on plenum fans and inline fans. Seismic restraint is also available for seismic active locations.

All single-speed motors are standard as premium efficiency, while 2-speed motors are high efficiency.

The fan bearings have a minimum L50 life of 200,000 hours, and are available as high as one million hours. Bearings are selected for minimum noise levels and minimal service. Bearings are self aligning and pre-lubricated for immediate use. Bearings are mounted on rigid frames and positioned to provide proper balance. All bearings include copper lubrication lines that are extended to the access side of the fan cabinet with the grease fittings located near the access door opening.

All fan motors are internally mounted. The appropriate motor size will be selected by the SelectTools software. Motors cannot be undersized, but may be oversized if desired. Motor options include open drip proof, totally enclosed fan cooled, 1 speed/1 winding, 2 speed/1 winding, and 2 speed/2 winding. Motor efficiencies available for high and premium efficiency, depending on the motor type.

Figure 8: Spring Isolation





## Fan Array

The fan array section will decrease the fan section length by using multiple smaller direct-drive fans. With the stacked array, the fans will also provide a more even airflow pattern throughout the unit and will allow the fans to be placed closer to the coil. Multiple fans also provide redundancy, allowing the system to deliver full airflow and static pressure if a fan or motor is lost. All fans in the fan array are direct-drive and offer more efficient performance with no belt losses and no required shaft bearing maintenance.

The DDPL fan array section has fan diameters from 12–33 inches, with arrangements of up to 24 fans. Daikin offers three motor control options to meet the highest level of redundancy. The array can be selected with a single VFD, a VFD per row or a VFD per fan. Each fan will come with an individual motor starter and backdraft prevention allowing complete isolation of any fan.

The ECM fan array section has a brushless, permanent magnet motor(s) for maximum efficiency. The inverter is integral to the motor. Each fan will come with an individual motor starter and optional backdraft prevention allowing complete isolation of any fan.

**Figure 9: Nine-Fan Option**



**Figure 10: ECM Fan Option**



## Coils

The Daikin Vision air handler offers broad application flexibility in coil sections and coils. Coils can be arranged in draw-through, blow-through, and multi-zone configurations. Heating only, cooling only, or cooling and heating sections are available. All coils are installed with space between each coil to allow access for cleaning and mounting of controls.

Cooling coil sections, and cooling and heating coil sections, are available in seven different section lengths to accommodate every application requirement. Drain pans extend the full length of the section. Removable access panels or doors may be provided in the deeper sections that will not interfere with piping connections extending through the unit side panels.

All cooling coils are mounted over a double sloped drain pan. The cooling coil rests on coil supports located over the drain pan. The drain pan extends beyond the leaving side of the coil to help recover condensate. The primary drain pan also extends under the coil headers and return bends to help remove condensate from the unit. A full thickness of insulation is always provided between the drain pan and the bottom outer panel. The drain pan is sloped in two planes to promote proper condensate removal.

Coil connections are grommet sealed inside and outside to ensure low cabinet leakage, and the connections always extend through the unit cabinetry, allowing for the easy connection of valves and piping (Figure 11). Water coil vents and drains are located outside the cabinetry.

Coils are available in a range of face area sizes, including small, medium, medium extended, large, extended and staggered. Generally, small face area coils are used for heating applications, large face area coils are used for cooling applications with bypass, and extended face area coils are used to maximize the unit cross section for restricted space applications. The extended coil is used to maintain coil face velocity limitations to avoid going to a larger cabinet size, saving valuable floor space and money.

With Daikin being a major manufacturer of heat transfer coils, the coil options are virtually unlimited. The Daikin contractor coil line has several coil types, ranging from hot and cold water, refrigerant and steam. Standard Daikin coils are ARI certified. In addition to a broad range of circuitings, fin spacing and row depths, coils can be constructed of different material types for fins, tubes, connections, and casings. This provides the ability to specify a coil to meet the application requirements.

For more information on Daikin coils, consult the following catalogs:

- Cooling—water/refrigerant . . . . . [Catalog 411](#)
- Heating—water/booster . . . . . [Catalog 412](#)
- Steam—standard/distributing . . . . . [Catalog 413](#)

**Figure 11: Coil Connections, Vents, Drains, and Drain Pan Connection, Extend Through Unit Cabinetry**



## Filters

The Daikin Vision air handler is designed to house flat, angular, bag, or cartridge filters. These media types range in efficiencies up to 95% and MERV 15. (See Table 2 for a description of the MERV Rating.) In addition to offering a full range of efficiencies, the filter media can be provided with an optional antimicrobial treatment. Antimicrobial treatments are highly recommended for a complete filtration system.

Daikin Vision air handlers can also be ordered with HEPA (MERV 17) filters. These filters have a minimum efficiency of 99.99% – 0.3 μm.

An optional filter pressure gauge may be ordered with each filter section to help promote regular servicing and prevent clogging.

Both bag and cartridge filters have a pre-filter and can be either side load or front load. An access door is provided on either side or both sides of the unit to access the filter section. Filters can be positioned anywhere in the unit, and as many filter sections as required can be used. Many health and food industries require stringent filtration. Often, a filter section must be the last component in the air stream. The Daikin Vision air handler meets these requirements by providing a filter section located as the last component in the air stream, and with full sheet metal liners.

**Figure 12: Filter Particle Size Chart (in microns)**

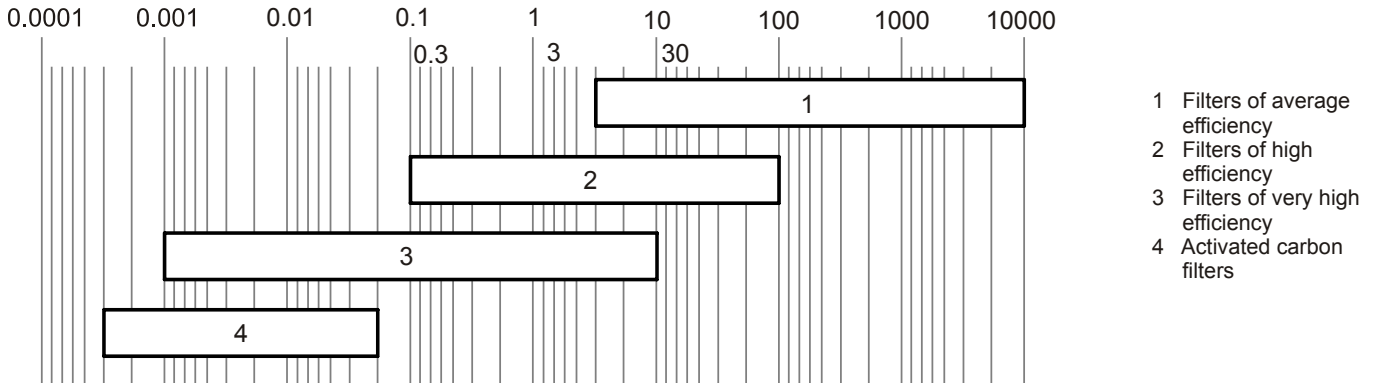

**Figure 13: Pollutant Particle Size Chart (in microns)**

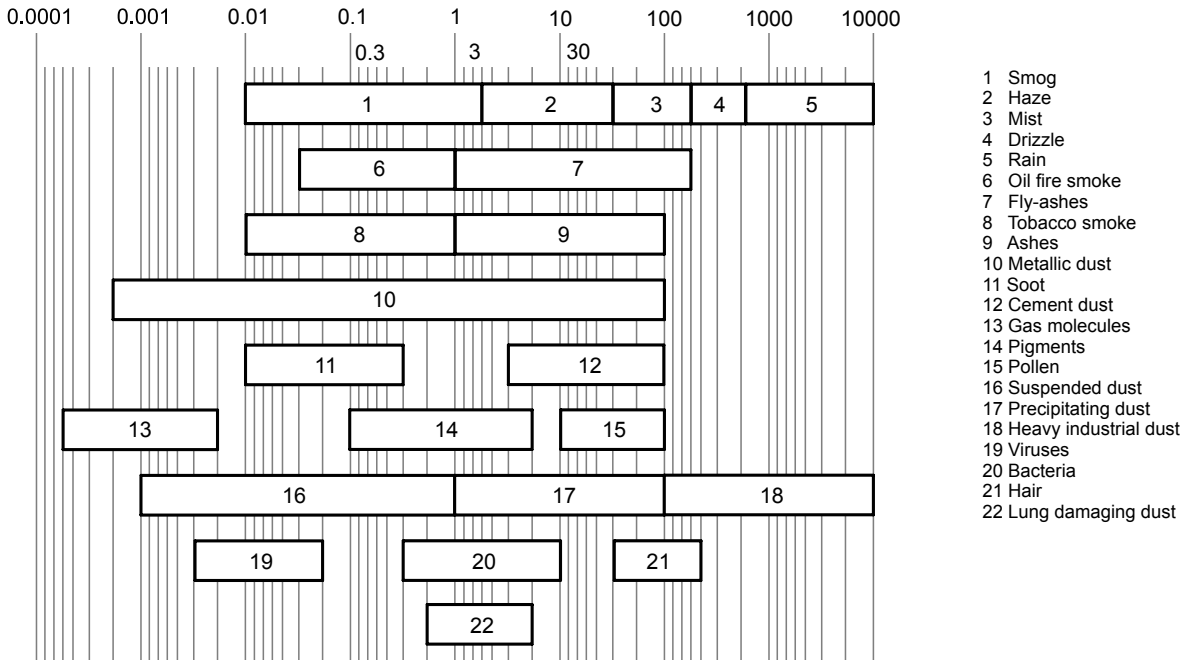

## What is the MERV Rating?

Minimum Efficiency Reporting Value (MERV)—ASHRAE Standard 52.2-1999 entitled “Method of Testing General Ventilation Air-Cleaning Devices for Removal by Particle Size” provides a methodology for determining filter efficiency at removing various sizes of particles (see [Figure 12](#)) as the filters become loaded. There are three ranges of particle sizes that define the MERV value:

Range 1—0.3 to 1.0 .m particle size.

Range 2—1.0 to 3.0 .m particle size.

Range 3—3.0 to 10.0 .m particle size.

The [Table 2](#) shows a comparison of the MERV rating to the average arrestance percentage by the older ASHRAE Standard 52.1 method:

**Table 2: MERV Rating vs. AHSHRAE Standard 52.1**

Standard 52.2 (MERV)	Approx. standard 52.1		Particle size range
	Dust spot efficiency	Arrestance	
15	>95%	n/a	1
14	90 to 95%	>98%	1
11	60 to 65%	>95%	2
8	30 to 35%	>90%	3
6	<20%	85 to 90%	3

### Standard Filter Types Available:

- MERV 8 – 2" or 4" depth. Pleated filter with two layers of added polypropylene laminate to increase efficiency.
- MERV 13 – 2" or 4" depth without 1" track.
- MERV 14, 13, and 11 – 4" depth, 1" track requirement. Mini pleated filters with metal cell sides and headers that provide superior moisture resistance.
- MERV 14, 13, and 11 – 12" depth, 1" track requirement. Steel interlocked header and cell sides hold the corrugated aluminum separated pleats allowing optimum airflow. Rated UL Class 1.
- MERV 14, 13, and 11 – 12" depth, 1" track requirement. Mini pleats held in a V-bank configuration providing greater airflow capacity and longer service.
- MERV 15, 14 and 12 – 36", 30" and 22" depths, 1" track requirement. Extended surface pockets made from high-loft, layered synthetic media. Rated UL Class 1 MERV 8 efficiency filters also available in 19", 15" and 12" depths.
- HEPA (MERV 17)
  - 99.99% – 0.3 mm (HEPA)
  - 99.999% – 0.3 mm (ULPA)
  - 99.99995% – 0.1 to 0.2 mm (ULPA)

## Ultraviolet Light Options

Vision air handlers can be factory equipped with ultraviolet (UV) light options that are pre-engineered for placement to provide maximum effectiveness. The first can be mounted on the downstream side of all cooling coils and above the unit drain pan for surface “kill” applications to comply with the GSA Facilities Standard for federal buildings. Agency approved to UL Category Code ABQK specification, HVAC Accessories, Air Duct Mounted, in addition to the ETL listing of Vision air handlers.

## Access

Access sections can be selected to meet specific application criteria. They can be placed anywhere in a unit in a variety of depths and are available in depths of 16" – 54". Typically, access sections are used for field-installed components, air monitoring devices, or to provide ample space between components.

## Mixing Boxes and Economizers

When outside and return air mixing is required, either a mixing box or an economizer section can be selected. Either component will regulate the amount of outside and return air supplied to the conditioned space. The mixing box or economizer can make use of free cooling by opening outside air dampers when the ambient air will help to condition the supply air stream. Additionally, dampers may be individually sized to provide better mixing.

Both the mixing box and economizer are provided with a Daikin UltraSeal™ low leak damper. This damper has one of the lowest leakage rates in the industry, maximizing energy efficiency. At 4.0" static pressure and a face velocity of 1100 fpm through the dampers, the leakage rate is less than 0.2% (it is common to specify leakage rates at higher static pressures, but dampers should not exceed 2" of static pressure). The parallel airfoil blades are hollow core and fully gasketed. Continuous vinyl seals are provided between the damper blades. Stainless steel end seals and linkage built into high strength ABS plastic endcaps provide smooth, quiet operation.

## Face and Bypass Dampers

Face and bypass dampers can be provided to modulate temperature by bypassing air around the coil. The opposed blades meter varying air volumes through the coil and bypass to attain the final air temperature demanded. Daikin Vision air handlers offer only low leak dampers in their face and bypass sections.

Three styles of face and bypass sections are available.

- Internal bypass is available for use with medium face area coils (Figure 14).
- External bypass and external right angle are used when larger face area coils are required. The damper blades are fabricated of continuous galvanized steel with the damper rods rotating in nylon bushings. Damper shaft extensions are supplied to facilitate damper motor location.
- Integral face and bypass. Vision air handlers are pre-engineered to provide an accurate, reliable method of preheating and tempering air in standard or make-up air applications. Integral face and bypass coils maintain constant steam pressure or tube velocities through the coil to help prevent freeze-ups, while varying airflow through the coil using bypass dampers. The amount of air bypassed or heated is determined by a preset leaving air temperature. It can vary from the bypass dampers being fully closed (all air passes through the coil) for maximum heat output, to the bypass dampers being fully open (no air passes through the coil) for minimum heat output. The air is then mixed at the discharge of the coil to achieve the desired leaving air temperature. Air pressure drop is maintained constant regardless of the position of the dampers.

**Figure 14: Internal Face and Bypass Dampers**





## Blenders/Air Mixers

Stratification can occur from the mixing box when airflow from two different temperature air streams do not mix completely. This incomplete mixing can continue through the air handler and subject an unprotected coil (no glycol) to freezing temperatures, damaging the coil. With the increased minimum outdoor air requirements as identified by ASHRAE Standard 62, the likelihood for air stratification increases. An air handler must be able to handle the required amount of outdoor air, regardless of temperature, without risking damage to the coil.

Blenders/air mixers help to provide protection for coils against freeze-up due to stratification. They add additional turbulence to the passing air streams, boosting the air velocity for improved mixing. Proper distance is provided immediately downstream to give the air streams enough time to fully mix before reaching the next air handler component. Because blenders/air mixers are static devices, they require no maintenance. Different blender/air mixer lengths can be selected to satisfy either the acoustic, space, pressure drop, or initial cost requirements. The Daikin SelectTools software can help select the appropriate blender/air mixer for the application.

**Figure 15: Blender**

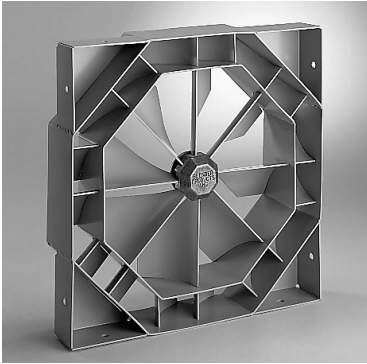

## Attenuators

Building occupants have become increasingly conscious of the quality of their environments, and low sound levels are a key criteria. Studies have confirmed improved productivity when workers are performing in sound-controlled environments. Consequently, building owners, engineers, and architects are designing their projects with stringent sound criteria to maximize this economic benefit.

Daikin Vision air handlers are designed to provide quiet sound levels. Factory-installed attenuators are available for the discharge or return sections of the air handling unit to meet the most stringent sound attenuation requirements. Different attenuator lengths can be selected to satisfy either the acoustic, space, pressure drop, or initial cost requirements. Quality construction and an aerodynamic design give reliable performance, low pressure drop and low initial cost. The Daikin SelectTools Software can help choose the correct attenuator for your application.

**Figure 16: Attenuator Section**



## Digital Ready™ Air Handlers

Vision Air Handlers can be factory-equipped with industry standard direct digital control (DDC) components for easy, low cost integration with controls by others. Sensors and actuators are selected for maximum compatibility with most DDC control systems, and are neatly wired within their shipping section to a conveniently located junction box. Digital Ready Vision air handlers save the time and costly labor needed to identify, purchase and field install DDC components to match your control system. You also benefit from uniform, proper positioning of DDC components at our factory, which promotes reliable start-up and operation.

## Starters and VFDs

A variety of factory-installed motor control options are available to provide operation and maintenance protection, motor efficiency, and flexibility for the Vision air handler. These options include: Disconnect Switch, Starters, Combination Starter/Disconnect, Variable Frequency Drive (VFD) with Disconnect Switch, and VFD with Disconnect Switch and Bypass. Line reactors are available on both VFD with Disconnect Switch and VFD with Disconnect Switch and Bypass.

A unit mounted disconnect switch provides the means for disconnecting power in sight from the motor when required by the National Electric Code (NEC). The switch is a heavy-duty type with a non-fused disconnect switch in a NEMA 1 enclosure. A fused disconnect is also available.

Factory mounted starters offer remote start/stop operation and overload protection for an individual fan motor with minimum field cost to wire line and control circuit power to the unit. All starters provided are NEMA rated. Additional options include auxiliary contacts, control transformer, selector switch, push buttons, and pilot lights. A combination starter is a starter packaged with a safety switch. These motor controllers provide remote start/stop operation as well as disconnecting means in sight of the controller.

A VFD provides adjustable speed control of a single fan motor. Factory mounted outside the fan cabinet, the VFD provides not only a lower cost than field installation, but also an optimal installation location. VFDs are preprogrammed and include a keypad for local or remote control.

A unit installed VFD with disconnect provides local or remote speed control for a single fan motor with disconnecting means within sight when required by the NEC. A non-fused disconnect is offered packaged with the VFD in a separate NEMA 1 enclosure. Installation is limited to the connection of power and control wires at the device.

Packaged VFD with disconnect and bypass offers added motor control at the unit for critical fan applications. With bypass control, power to the VFD can be switched to allow full operation of the fan motor in case of VFD failure. VFDs with disconnect switch, bypass and line reactors provide harmonic control when needed.

## Energy Recovery

Maintaining acceptable indoor air quality is generally accomplished by introducing ventilation from outdoors. The air must be conditioned to match the indoor space requirements. Heat wheels and fixed plate heat exchangers are available as factory-installed options for Vision air handlers. These energy recovery components can recover 50% or more of the energy normally exhausted from a building. These devices capture heat from exhaust air as it passes through the air handler and transfer it to the supply air stream, reducing the cost of heating or cooling the outside air. Energy recovery components do this by transferring energy from a warm air stream to a colder air stream—heating cold outside air during the winter and cooling hot air during the summer.

The fixed plate creates a cross flow as it collects heat and conducts it to the other side of the plate. The fixed plate has no moving parts, is easy to clean, has a low pressure drop, can be sealed against cross contamination, and is offered in a wide range of configurations. Flat plate heat exchangers are offered in both sensible-only and enthalpy (sensible and latent) arrangements.

The heat recovery wheel rotates at low speeds, capturing and transferring both sensible (heat) energy and latent (moisture) energy. The ability to transfer both sensible and latent energy gives the heat wheel several advantages. First, the required capacity of ventilation equipment is significantly reduced. Additionally, the heat wheel works at lower temperatures without frosting. The supply air from the heat wheel is not near saturation, and moisture in the ductwork is not an issue.

Further, no condensate pan or drain is required. Finally, heat wheels provide humidification so that the humidifier can be downsized. They also help to keep humidity in spaces where humidification is not applied, providing greater comfort to these zones. Both types of energy recovery devices are configured on the inlets and outlets with splice collars to match the adjacent sections. The fixed plate requires two drip pans..

The side-by-side arrangement will often fit an energy recovery unit into spaces with height restrictions relative to the standard stacked arrangement. For example, if the application requires 9,000 CFM and bypass dampers, the stacked arrangement would require 108" in total height while the side-by-side would only need 72", but will require an added 62" in width. This arrangement will also allow easy access to both supply and return air streams since both are on the same level.

Since the diameter of the energy recovery wheel will often be the limiting factor of the unit height, the selection of the side-by-side arrangement will almost always require custom cabinet dimensions.

## Electric Heaters

Electric heaters extend the versatility of the Vision air handler. With negligible air pressure drop, accurate controllability, light weight, easy serviceability and inherent freeze protection, electric heaters are valuable alternatives to conventional steam and hot water heating coils.

ETL-approved electric heaters are available on all standard sizes (003-090) for horizontally-mounted draw through units in both left and right hand configurations. All units are open wire style construction, with automatic and manual backup limit controls, air switch, stainless steel terminals, power on pilot light, magnetic contactors and integral control boxes. Safety interlock switches, step controllers and vernier silicon controlled rectifiers (SCRs) are available options.

The heater requires its own electric service. Heaters are available in 208V, 240V, 480V and 600V (all 3 phase) and use an internal 24-volt control circuit. Standard kW ranges are available for each heater size and are designed to give an approximate temperature rise from 20°F to 60°F, depending on the airflow through the unit. Typical pressure drops range from .01 to .04 inches of water, depending on the air velocity and number of rows of heating elements.

An integral control box with optional door handle power disconnect is included with the electric heater. Insulated panels are factory installed behind the control box. Any standard motor may be used, although the discharge air from the electric heater must not exceed 104°F since the rated ambient temperature of the motor will be exceeded. The heater is assembled into a separate section of the Vision air handler. Standard section widths include 30", 34", 42", and 46" and vary depending on unit size, control type and kW used.

Selecting flexible Vision air handlers depends on many different criteria. The Quick Select tables on [page 26](#) and [page 27](#) provide a rough determination of air handler needs. To simplify this process, Daikin designed an innovative computerized selection program—Daikin SelectTools software. It allows the user to develop an air handler from the ground up and obtain all of the detail required for proper design and specification. The user can design a unit in a matter of minutes.

The program is completely integrated. All input data is carried through the selection process and considered as calculations are made. Because the program is integrated, the opportunity for errors is reduced. The software guides the user through the selection process. On-line editing helps select only viable options. The program is provided so that even the less experienced user can select air handlers accurately.

Designing an efficient air handler system depends on accurate system design and proper equipment selection. Factors that affect unit selection include applicable codes, ventilation requirements, heating and cooling space loads, acceptable temperature differentials, and thermal media and installation limitations. Unit selection can be broken down into four steps: unit type and size, coils, accessories, and fan and motor requirements.

Generally, the unit is selected based on the air volume required and the desired face velocity through the cooling coil. For cooling coils, 400 to 525 feet per minute is considered the optimum face velocity range for dehumidification and the prevention of any moisture carryover. The Daikin SelectTools software recommends the unit size based on air flow and face velocity requirements. Once the unit size is determined, select the coils and all accessory components. Once all components and coils are selected (identifying the total internal component pressure drop), select the fan.

## Selecting Coils

The Vision air handler provides the ability to select from multiple face area coils per unit size. Once the coil size is selected, the row and fin requirements can be determined based on performance criteria. Daikin offers an extensive line of coil types and circuitings. This wide variety of circuiting, row, and fin spacing, in addition to different material types, can provide a coil selection that handles the load required.

Heating, cooling, and combination cooling and reheat sections are available. Coil sections come in many different depths to accommodate multiple rows of coils, and to provide access on the leaving air side or between coils for cleaning and inspection of the drain pan. Access in the coil section can be minimized or maximized depending on the space available and job needs. Coil sections can be placed as needed in the unit, and as many sections as required for conditioning of air can be provided.

## Selecting Accessories

A complete selection of component and section types in a variety of unit arrangements and configurations is available for air mixing, filtration, and temperature control to meet specific application requirements. The outside and/or return air can be brought into the unit through a plenum, mixing box, or economizer. For mixing of the two air streams, dampers are required to modulate and direct outside and return air, which is accomplished using a mixing box or economizer. Both section types use the Daikin patented UltraSeal™ low leak dampers. Blenders/air mixers also are available to provide proper mixing of two air streams, to prevent stratification and to help avoid damage to equipment due to freezing temperatures.

To promote good air filtration, many different filter media types and arrangements are offered. Filters can be provided in angular or flat filter racks, a variety of media efficiencies, and with or without a prefilter. The filter section can be located anywhere in the unit to filter air as it enters the unit, or in a final filter arrangement before it leaves the unit. Bag or cartridge filters can be either front or side loading.

Also available are many different size access sections for field-installed components or to provide access between components. Other options include diffusers, plenums, face and bypass dampers, sound attenuators, and blenders/air mixers. Standard access doors open outward for maximum accessibility to internal components.

On pressurized sections, most doors open inward to help maintain the extremely low cabinet leakage rate of the Vision unit and to prevent doors from being inadvertently opened when the cabinet is under pressure.

## Selecting Fans

### **WARNING**

#### **SMOKE CONTROL AND MANAGEMENT SYSTEMS**

Improper smoke or fume air handling can result in severe personal injury or death. A registered professional engineer must design and approve the air conditioner and air handler application to make sure smoke and fume control meet local fire codes and NFPA requirements for the specific building application.

Fan selection requires an accurate calculation of the resistance to the airflow through the entire system. This total resistance consists of the sum of two parts—the external and internal static pressure. The external static pressure is the static pressure found in the distribution system, external to the air handler. The internal unit resistance is the sum of the resistance of the coils and various other unit components and accessories. Component pressure drops are listed for specific air flows in this catalog.

Use the Daikin SelectTools software to determine internal component pressure drops of the system. Once the total static pressure is known, the software identifies the fans available to properly handle the air flow and static pressure for the system. The software generates a full fan curve based on the fan selection and point of operation.

**Table 3: Quick Select, Unit Sizes 003 to 021**

Description	Unit size								
	003	004	006	008	010	012	014	017	021
Airflow range, cfm	900–2500	1200–3100	1700–4600	2200–6000	2900–7700	3600–9700	4200–11200	5000–13500	6000–16000
cfm @ 500 ft/min through large face area coil	1550	1950	2850	3750	4800	6050	7000	8400	10050
Height × width (in)	26 × 38	30 × 40	30 × 52	34 × 58	36 × 64	42 × 66	42 × 74	46 × 80	58 × 82
<b>Cooling coil face area, sq ft</b>									
Extended/staggered large	3.9	4.8	6.6	8.5	10.7	13.5	15.4	18.3	21.9
Large	3.1	3.9	5.7	7.5	9.6	12.1	14.0	16.8	20.1
Extended/staggered medium	2.6	3.4	4.7	6.4	8.3	9.8	11.2	13.7	17.2
Medium	2.1	2.8	4.1	5.6	7.4	8.8	10.2	12.6	15.8
Small	N/A	2.3	3.3	4.7	6.4	7.7	8.9	11.2	14.4
<b>Fan section—depth (in)</b>									
Largest housed fan and motor avail. w/ top hor. dischg.	32	32	36	40	40	46	46	50	52
Largest inline fan and motor available	N/A	N/A	N/A	N/A	N/A	44	44	50	54
Largest belt-drive plenum fan and motor available	N/A	N/A	32	32	34	40	40	44	48
Largest direct-drive plenum fan and motor available	N/A	36	36	42	46	50	50	58	60
Largest dual direct-drive plenum fan and motor available	N/A	36	36	42	46	50	50	58	60
Largest twin fan and motor available	N/A	N/A	N/A	50	56	56	58	58	66
Largest ECM fan available	N/A	30	30	30	30	30	30	30	30
<b>Mixing box—depth (in)</b>									
Mixing box only	20	20	20	20	22	24	24	26	30
Mixing box with flat filter	24	24	24	24	26	28	28	30	34
Mixing box with angular filter	42	42	42	42	44	46	46	48	52
<b>Economizer—depth (in)</b>									
	40	40	40	40	44	48	48	52	60
<b>Blender—depth (in)</b>									
Largest Kees	18	20	24	26	28	34	36	38	42
Largest Blender Products IV	18	22	26	30	34	38	40	46	48
<b>Side load filter sections—depth (in)</b>									
Flat 2" and 4"	12	12	12	12	12	12	12	12	12
2" angular	32	30	30	30	30	30	30	30	30
Cartridge (12" deep w/ 2" pre-filter)	22	22	22	22	22	22	22	22	22
Bag (36" w/ 2" pre-filter)	42	42	42	42	42	42	42	42	42
<b>Front load filter sections—depth (in)</b>									
Cartridge (12" deep w/ 2" pre-filter)	16	16	16	16	16	16	16	16	16
Bag (36" w/ 2" pre-filter)	40	40	40	40	40	40	40	40	40
<b>Face and bypass—depth (in)</b>									
Internal	12	12	12	12	12	12	12	12	12
External	18	18	18	20	22	24	24	26	30
<b>Coil sections—depth (in)</b>									
Heating only (2-row water)	12	12	12	12	12	12	12	12	12
Cooling only (4-row water)	18	18	18	18	18	18	18	18	18
Cooling only (6-row water)	24	24	24	24	24	24	24	24	24
Cooling & reheat (12-row cooling & 1-row heating)	36	36	36	36	36	36	36	36	36
Vertical cooling only (6-row water)	30	30	30	30	36	36	36	36	42
<b>Multi-zone coil section—depth (in)</b>									
3 deck horizontal with dampers	N/A	N/A	40	42	42	52	52	54	56
<b>Access sections—depth (in)</b>									
16" deep	16	16	16	16	16	16	16	16	16
24" deep	24	24	24	24	24	24	24	24	24
30" deep	30	30	30	30	30	30	30	30	30
36" deep	36	36	36	36	36	36	36	36	36
42" deep	42	42	42	42	42	42	42	42	42
48" deep	48	48	48	48	48	48	48	48	48
54" deep	54	54	54	54	54	54	54	54	54
<b>Diffuse—depth (in)</b>									
With housed fan	10	10	10	12	12	16	16	16	16
With inline fan	N/A	N/A	N/A	N/A	N/A	18	18	18	22
<b>Attenuator—depth (in)</b>									
Short	40	40	40	40	40	40	40	40	40
Medium	52	52	52	52	52	52	52	52	52
Long	64	64	64	64	64	64	64	64	64
<b>Supply or return plenum—depth (in)</b>									
Top, bottom or end opening	14	16	16	18	20	22	22	24	28

**Note:** Based on typical industry sizes, Vision air handler units are available in 2-inch increments of height and width to fit the exact space requirements.

**Table 4: Quick Select Table, Sizes 025 to 090**

Description	Unit size								
	025	030	035	040	050	065	080	085	090
Airflow range, cfm	7300–19400	8500–22500	10000–26500	11500–31000	15000–40000	20000–54000	21500–57500	23100–61600	24600–65600
cfm @ 500 feet/minute through large face area coil	12150	14150	16700	19300	24500	33300	35900	38450	41000
Height × width, in	60 × 86	60 × 98	66 × 102	68 × 116	80 × 120	92 × 136	98 × 136	104 × 136	110 × 136
<b>Cooling coil face area, sq ft</b>									
Extended/staggered large	27.4	31.9	37.1	42.9	58.0	76.9	82.0	87.1	92.2
Large	24.3	28.3	33.4	38.6	49.0	66.6	71.8	76.9	82.0
Extended/staggered medium	21.3	24.8	29.7	34.3	40.1	61.5	61.5	66.6	71.8
Medium	18.2	21.2	24.1	30.0	35.7	51.2	51.2	56.4	61.5
Small	16.7	19.5	22.3	27.9	31.2	46.1	46.1	51.2	56.4
<b>Fan section—depth, in</b>									
Largest housed fan and motor avail. w/ top hor. dischg.	58	58	58	70	80	92	92	92	92
Largest inline fan and motor available	64	64	70	70	90	96	96	96	96
Largest belt-drive plenum fan and motor available	50	54	54	52	60	68	68	68	68
Largest direct-drive plenum fan and motor available	66	66	66	74	78	78	78	78	78
Largest dual direct-drive plenum fan and motor available	66	66	66	74	78	78	78	78	78
Largest twin fan and motor available	66	74	82	82	82	N/A	N/A	N/A	N/A
Largest ECM fan available	N/A	30	30	30	30	30	30	30	30
<b>Mixing box—depth, in</b>									
Mixing box only	32	32	36	36	40	46	50	54	56
Mixing box with flat filter	36	36	40	40	44	50	54	58	60
Mixing box with angular filter	54	54	58	58	62	68	72	76	78
<b>Economizer—depth, in</b>									
	64	64	72	72	80	92	100	108	112
<b>Blender—depth, in</b>									
Largest Kees	46	48	58	58	68	76	80	84	84
Largest Blender Products IV	52	60	64	70	74	88	88	92	92
<b>Side load filter sections—depth, in</b>									
Flat 2" and 4"	12	12	12	12	12	12	12	12	12
2" angular	32	32	32	32	32	32	32	32	32
Cartridge (12" deep w/ 2" pre-filter)	22	22	22	22	22	22	22	22	22
Bag (36" w/ 2" pre-filter)	42	42	42	42	42	42	42	42	42
<b>Front load filter sections—depth, in</b>									
Cartridge (12" deep w/ 2" pre-filter)	16	16	16	16	16	16	16	16	16
Bag (36" w/ 2" pre-filter)	40	40	40	40	40	40	40	40	40
<b>Face and bypass—depth, in</b>									
Internal	12	12	12	12	12	12	12	12	12
External	32	32	34	38	44	50	54	56	58
<b>Coil sections—depth, in</b>									
Heating only (2-row water)	12	12	12	12	12	12	12	12	12
Cooling only (4-row water)	18	18	18	18	18	18	18	18	18
Cooling only (6-row water)	24	24	24	24	24	24	24	24	24
Cooling & reheat (12-row cooling & 1-row heating)	36	36	36	36	36	36	36	36	36
Vertical cooling only (6-row water)	48	48	54	N/A	N/A	N/A	N/A	N/A	N/A
<b>Multi-zone coil section—depth, in</b>									
3 deck horizontal with dampers	60	60	70	70	76	88	N/A	N/A	N/A
<b>Access sections—depth, in</b>									
16" deep	16	16	16	16	16	16	16	16	16
24" deep	24	24	24	24	24	24	24	24	24
30" deep	30	30	30	30	30	30	30	30	30
36" deep	36	36	36	36	36	36	36	36	36
42" deep	42	42	42	42	42	42	42	42	42
48" deep	48	48	48	48	48	48	48	48	48
54" deep	54	54	54	54	54	54	54	54	54
<b>Diffuser—depth, in</b>									
With housed fan	24	24	24	30	30	30	30	30	30
With inline fan	26	26	28	30	36	38	38	38	38
<b>Attenuator—depth, in</b>									
Short	40	40	40	40	40	40	40	40	40
Medium	52	52	52	52	52	52	52	52	52
Long	64	64	64	64	64	64	64	64	64
<b>Supply or return plenum—depth, in</b>									
Top, bottom or end opening	30	30	32	32	38	42	48	52	54

**Note:** Based on typical industry sizes, Vision air handler units are available in 2-inch increments of height and width to fit the exact space requirements.



## Installation Flexibility

Daikin central station Vision air handlers feature sectionalized design and can ship fully assembled or in sections as required by the job site condition to provide maximum installation flexibility. Multiple fan, coil, filter, mixing box, face and bypass, and access components allow the design flexibility of built-up systems with the cost advantage of factory fabricated units. Units can be shipped from the factory in as few or as many sections as required according to job site condition.

## Mounting and Access

Whether units are floor or ceiling mounted, take care to keep the supporting structure level and rigid enough for satisfactory unit operation. Ideally, a heavy concrete slab should be used for floor mounted units and main support beams should be used for ceiling supported units. Ceiling suspended units must be trapeezed from the unit base rail or field-supplied materials. Avoid long floor or ceiling spans.

Locate units so there is proper access for routine service. Clearance for filter removal on both sides of the filter section is usually necessary. Provide clearance as required for access panels. Allow room for coil removal. Cooling units require clearance for a trap in the drain pan line.

Access to the interior of the Vision air handler is provided by hinged access doors or removable panels. For access between components, versatile access sections feature hinged access doors on either or both sides.

## Ductwork

A well-designed duct layout minimizes system resistance and sound generation. Duct connections to and from units should allow straight, smooth airflow. Avoid discharge plenums or any abrupt change in duct size. Also avoid sharp turns in the fan discharge, particularly turns opposed to wheel rotation. If sharp bends are necessary, use turning vanes. See Figure 17 for good fan outlet practices.

Figure 17: Discharge Duct Layout

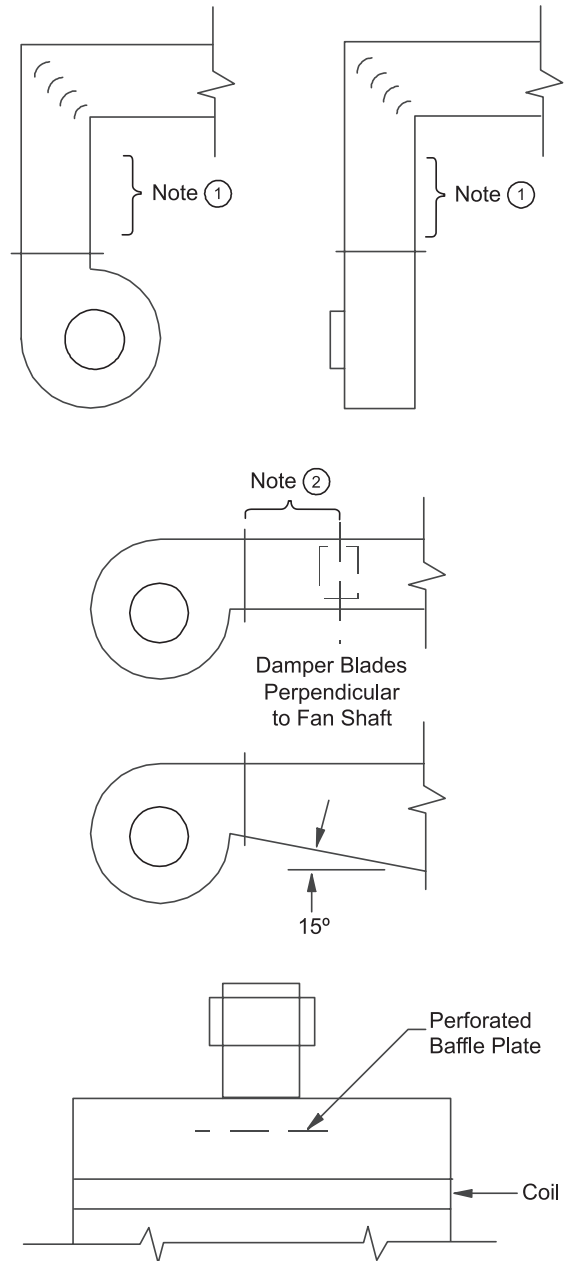

**NOTE:** Elbows should not be closer than 1-1/2 to 2-1/2 times the largest dimension of fan discharge opening. Place dampers at least 3 fan diameters downstream of the fan discharge.

Figures reprinted with permission from the 1979 ASHRAE Guide and - Data Book (Equipment).



## Piping and Drain Pan Traps

Design and install piping in accordance with accepted industry standards. Do not apply undue stress at the connection to coil headers. Support pipe work independently of the coils with adequate piping flexibility for thermal expansion. Run drain lines and traps full size from the drain pan connection. Drain pans must have traps to allow the condensate from the coils to drain freely. On a draw-through unit, the trap depth and the distance between the trap outlet and drain pan outlet should be twice the negative static pressure under normal unit operation. See Figure 18.

**Figure 18: Drain Pan Traps**

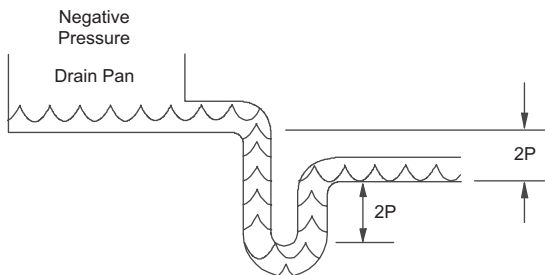

## Vibration Isolation

To help keep noise and vibration compatible with the intended use of the conditioned air space, apply good acoustical and vibration engineering practices during the early stages of design.

Since most applications require vibration isolation, the Vision air handler is available with factory-installed internal isolation. Internally isolated units feature spring or rubber in shear isolators sized specifically for each fan wheel and unit size.

## Multi-zone Air Handler Applications

Blow-through air handlers are available in single-zone, two-deck, and three-deck configurations. The two-deck and three-deck units are offered with or without zone dampers. All unit configurations include a perforated plate fan discharge diffuser to provide even airflow downstream of the fan.

Multi-zone and dual duct air handlers typically provide comfort conditioning by distributing a constant air volume at variable temperature. In a typical system, a portion of the air is heated by passing through the heating coil; the balance is cooled by the cooling coil. The heated and cooled airstreams are then mixed in the required proportion to provide the optimum temperature air to the conditioned space.

For dual duct applications, a pair of ducts bring heated and cooled air to the air mixing terminal boxes where the airstreams are mixed. By adding zone dampers to the dual duct unit, the air mixing takes place at the unit discharge and only one duct is required to distribute conditioned air to the building. The air mixing terminal boxes also are eliminated.

By adding a third bypass deck to the hot and cold decks, a triple deck multi-zone is created. The triple deck configuration offers significant energy conservation opportunities by allowing return or outside air to bypass both coils. The thermal inefficiency of mixing heated and cooled air is eliminated by the addition of the bypass deck. Bypass air is mixed with heated air for building zones that require heating. Bypass air is mixed with cooled air for building zones that require cooling.

Multi-zone air handling systems result in an absence of water, steam and condensate drain piping, wiring, electrical and mechanical equipment in the conditioned space for more usable commercial floor area and higher rental income.

## Sound

The unit inlet, outlet, and radiated sound levels for each octave band are calculated by the Daikin SelectTools software, based on your specific application. Sound performance data is derived from testing performed in accordance with AMCA Standard 300. The effects of various components, casework, and unit configurations are taken into account.

## Air Supply Systems and Fan Laws

An air supply system consists of an air handler cabinet, heat exchanger, filters, ductwork, grilles and registers used to distribute air throughout the building. The system is independent of the fan used to supply the system.

The resistance of the system, referred to as static pressure (SP), is dependent upon the quantity of air (cfm) that is moved through it. The air quantity is determined by the cooling, heating, and ventilating requirements.

For any system, the static pressure varies directly as the square of the air quantity. This relationship between cfm and SP establishes the system curve for that system and is expressed as follows:

$$\left(\frac{cfm_1}{cfm_2}\right)^2 = \frac{SP_1}{SP_2} \quad \text{or} \quad SP_2 = SP_1 \left(\frac{cfm_2}{cfm_1}\right)^2$$

The system curve is unique for a particular system configuration. Any change to the system caused by dirty filters, damper changes, etc., results in a new system curve.

For fans operating at low pressures (less than 10" W.G.), the effects of air compression are negligible. Disregarding air compression allows fan operation in a fixed system to be expressed by simple relationships. These relationships are known as fan laws and can be used to calculate the effects of fan speed and air density changes on this system.

Figure 19: Blow-Through Handler Configurations

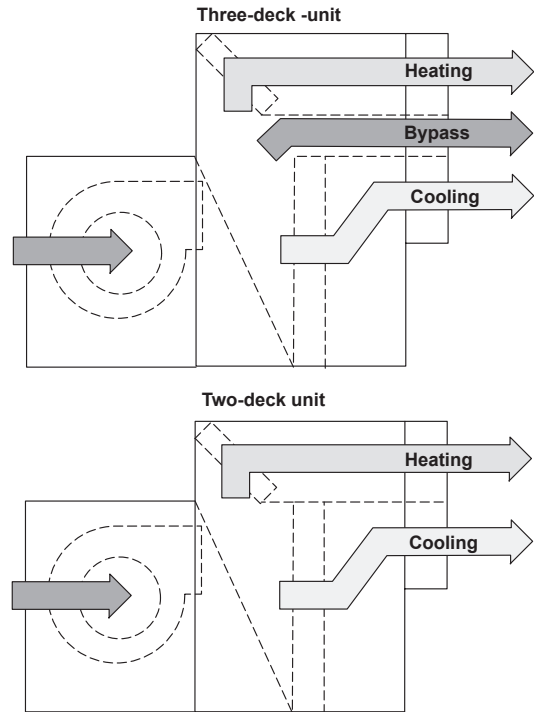

1 The flow rate varies directly with the change in fan speed:

$$\frac{cfm_1}{cfm_2} = \frac{rpm_1}{rpm_2} \quad \text{or} \quad cfm_2 = cfm_1 \left(\frac{rpm_2}{rpm_1}\right)$$

A 10% increase in fan speed increases air quantity 10%.

2 The static pressure varies as the square of the change in fan speed:

$$\frac{SP_1}{SP_2} = \left(\frac{rpm_1}{rpm_2}\right)^2 \quad \text{or} \quad SP_2 = SP_1 \left(\frac{rpm_2}{rpm_1}\right)^2$$

A 10% increase in fan speed increases static pressure 21%.

3 The fan brake horsepower varies as the cube of the change in fan speed:

$$\frac{HP_1}{HP_2} = \left(\frac{rpm_1}{rpm_2}\right)^3 \quad \text{or} \quad HP_2 = HP_1 \left(\frac{rpm_2}{rpm_1}\right)^3$$

A 10% increase in fan speed increases horsepower 33%.

4 System static pressure and brake horsepower are directly proportional to the air density:

$$SP_2 = SP_1 \left(\frac{\text{density}_2}{\text{density}_1}\right) \left(\frac{rpm_2}{rpm_1}\right)^3$$

$$HP_2 = HP_1 \left(\frac{\text{density}_2}{\text{density}_1}\right) \left(\frac{rpm_2}{rpm_1}\right)^3$$

Consequently, the static pressure and brake horsepower decrease with an increase in air temperature or higher altitude, and increase with a decrease in air temperature or lower altitude.

To determine fan performance for temperatures and altitudes other than standard (70°F, 0 ft. altitude), the static pressure must be adjusted by the density ratio before the fan rpm and bhp requirements can be determined. Density ratios are expressed as temperature and altitude conversion factors in [Table 7](#).

**Table 5: Temperature and Altitude Conversion Factors**

Air temp. (°F)	Altitude (ft)								
	0	1000	2000	3000	4000	5000	6000	7000	8000
-20	1.20	1.16	1.12	1.08	1.04	1.00	0.97	0.93	0.89
0	1.15	1.10	1.08	1.02	0.99	0.95	0.92	0.88	0.85
20	1.11	1.06	1.02	0.98	0.95	0.92	0.88	0.85	0.82
40	1.06	1.02	0.98	0.94	0.91	0.88	0.84	0.81	0.78
60	1.02	0.98	0.94	0.91	0.88	0.85	0.81	0.79	0.76
70	1.00	0.96	0.93	0.89	0.86	0.83	0.80	0.77	0.74
80	0.98	0.94	0.91	0.88	0.84	0.81	0.78	0.75	0.72
100	0.94	0.91	0.88	0.84	0.81	0.78	0.75	0.72	0.70
120	0.92	0.88	0.85	0.81	0.78	0.76	0.72	0.70	0.67
140	0.89	0.85	0.82	0.79	0.76	0.73	0.70	0.68	0.65
160	0.85	0.82	0.79	0.76	0.74	0.70	0.68	0.65	0.63
200	0.80	0.77	0.75	0.72	0.69	0.67	0.64	0.62	0.60
250	0.75	0.72	0.69	0.67	0.65	0.62	0.60	0.58	0.56

**Figure 20: Fan and Motor Heat Gain**

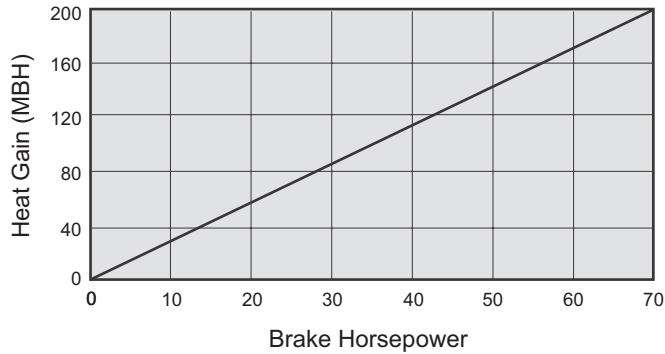

## Fan and Motor Heat

**Motor and drive heat**—The total energy input to any fan motor is consumed in two ways: by heat dissipated through the motor frame and by work output. The amount of heat dissipated by the motor is a function of its operating efficiency:

$$\text{Motor heat} = \text{input} \times (1 - \text{motor efficiency})$$

A small amount of the motor work output is dissipated by the drive mechanism, which also results in a heat gain. Belt-drive losses are a function of belt tension and number of belts as well as power transmitted. Typical belt-drive losses range from 2% to 6% of bhp.

Whether motor and drive heat gain become part of an air handling system cooling load depends on the motor location relative to the conditioned space. For air handlers with internal motors, the motor and drive are within the conditioned space. Therefore, the motor and drive add heat to the system. Subtract this heat from the cooling capacity and add it to the heating capacity of the unit.

**Fan heat generation**—All of the power input to a fan results in heat gain, which must be considered as a cooling load. The amount of heat generated is directly proportional to the fan bhp:

$$\text{Fan heat (Btuh)} = \text{bhp} \times 2545$$

Much of this heat generation occurs within the fan itself. Fans are not 100% efficient, and the energy losses that occur convert directly into heat. The work done by the fan on the airstream increases the temperature, pressure, and velocity of air. The heat of compression required to raise the airstream to this increased energy level is also a heat gain.

As the air travels throughout the building, its energy is deteriorated by friction, resulting in pressure drop. This is also heat gain, but it does not result in temperature rise because the air expands as the pressure is reduced. The expansion is a cooling process that offsets the heat generated by friction.

Typical fan and motor heat values are given in [Figure 20](#).

## Variable Air Volume

Daikin variable air volume systems (VAV) employ the concept of varying the air quantity to a space at a constant temperature thereby balancing the heat gains or losses and maintaining the desired room temperature. This true variable volume system is commonly referred to as a “squeeze-off” or “pinch-off” system. Unlike a “bypass” or “dump” system, supply air is diverted from areas where it is not required to areas that need cooling and, at system part load conditions, reduces the total fan volume. This ability to reduce supply air quantities not only provides substantial fan energy savings at partial load conditions, but it also minimizes equipment sizing.

Variable volume systems offer the following advantages:

- Lowers system first cost by using system diversity to reduce equipment and duct sizes.
- Lowers operating costs by reducing fan energy demands, especially at part load conditions.
- Lowers first cost by reducing space requirements for duct trunks and mechanical equipment.
- Provides system flexibility to match changing occupancy demands.

## Variable Frequency Drives

Variable frequency drives offer reliable operation over a wide range of airflow, with advantages in sound and energy performance.

Variable frequency drives provide the most efficient means of variable volume control by taking advantage of the fan law relation between fan speed (rpm) and fan brake horsepower (bhp). Also, since airflow is reduced by changing fan speed, the noise penalties often associated with mechanical control devices, e.g. inlet vanes, are not introduced. The following equation illustrates how fan bhp varies as the cube of the change in fan speed: :

$$HP_2 = HP_1 \left( \frac{\text{density}_2}{\text{density}_1} \right) \left( \frac{\text{rpm}_2}{\text{rpm}_1} \right)^3$$

In an ideal system, at 50% fan speed, brake horsepower would be reduced to 12.5% of that at full speed.

Variable frequency control varies the speed of the fan by adjusting the frequency and voltage to the motor. Keeping a constant volts/frequency ratio (constant magnetic flux) to the motor allows the motor to run at its peak efficiency over a wide range of speeds and resulting fan airflow volumes. [Figure 21](#) illustrates on a fan curve the effect of varying air volume with a variable frequency drive.

**Figure 21: Variable Frequency Drive Control**

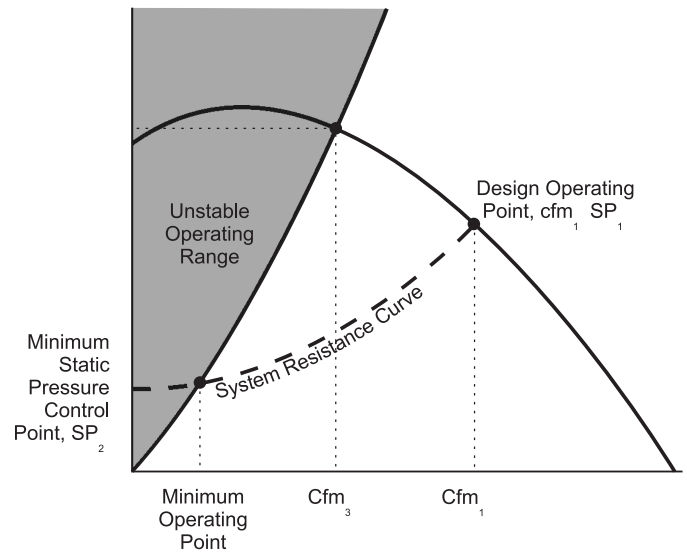

**Table 6: Component Pressure Drops (inches of water)**

Unit size	cfm	Dampers		F and BP face			F and BP by-pass			Plenum		Diffuser	Blender**			Attenuator		
		MXB	Econ.	Int. small	Int. med.	Large	Int. small	Int. med	Large	Top/bot. inlet	Top/bot. outlet		One	Two	Three	3 ft	4 ft	5 ft
003	900	0.01	0.02	—	0.03	0.01	—	0.09	0.03	0.01	0.01	0.15	0.06	0.03	—	0.01	0.01	0.01
	1200	0.03	0.04	—	0.06	0.02	—	0.15	0.05	0.03	0.02	0.15	0.11	0.05	—	0.02	0.02	0.02
	1500	0.04	0.06	—	0.09	0.03	—	0.24	0.07	0.04	0.03	0.15	0.17	0.08	—	0.03	0.03	0.03
	1800	0.06	0.09	—	*	0.04	—	*	0.11	0.06	0.04	0.15	0.24	0.11	—	0.04	0.05	0.05
004	1200	0.02	0.03	0.05	0.03	0.01	0.05	0.14	0.04	0.01	0.01	0.15	0.04	0.05	—	0.01	0.01	0.01
	1600	0.04	0.06	0.09	0.06	0.02	0.08	0.24	0.06	0.03	0.02	0.15	0.07	0.08	—	0.02	0.02	0.02
	2000	0.06	0.09	*	0.09	0.03	*	0.38	0.10	0.04	0.02	0.15	0.11	0.13	—	0.03	0.04	0.04
	2400	0.09	0.13	*	0.13	0.05	*	0.54	0.14	0.06	0.03	0.15	0.16	0.18	—	0.05	0.05	0.06
006	1700	0.02	0.03	0.05	0.03	0.01	0.04	0.12	0.04	0.01	0.01	0.15	0.10	0.05	0.04	0.01	0.01	0.01
	2300	0.04	0.06	0.08	0.05	0.02	0.08	0.23	0.07	0.02	0.02	0.15	0.18	0.09	0.07	0.02	0.03	0.03
	2900	0.06	0.09	*	0.09	0.03	0.12	0.36	0.11	0.04	0.03	0.15	0.28	0.14	0.11	0.04	0.04	0.05
	3500	0.09	0.14	0.11	*	0.05	0.17	0.50	0.15	0.06	0.04	0.15	0.41	0.20	0.16	0.06	0.06	0.07
008	2200	0.03	0.04	0.04	0.02	0.01	0.06	0.16	0.04	0.01	0.01	0.15	0.07	0.05	0.03	0.01	0.01	0.02
	3000	0.05	0.07	0.07	0.04	0.01	0.10	0.30	0.08	0.03	0.01	0.15	0.14	0.09	0.06	0.02	0.03	0.03
	3800	0.08	0.12	*	0.06	0.02	0.15	0.48	0.12	0.04	0.02	0.15	0.22	0.15	0.10	0.03	0.04	0.05
	4600	0.12	0.17	*	0.09	0.03	0.22	0.70	0.18	0.06	0.03	0.15	0.32	0.22	0.14	0.05	0.06	0.08
010	2900	0.03	0.04	0.03	0.02	0.01	0.08	0.22	0.04	0.01	0.01	0.15	0.09	0.06	0.06	0.01	0.02	0.02
	3900	0.05	0.07	0.05	0.04	0.02	0.14	0.39	0.08	0.03	0.02	0.15	0.17	0.11	0.11	0.02	0.03	0.04
	4900	0.08	0.10	0.08	0.06	0.02	0.22	0.62	0.13	0.04	0.02	0.15	0.26	0.17	0.18	0.04	0.05	0.07
	5900	0.12	0.15	0.10	0.08	0.04	0.29	0.90	0.18	0.06	0.04	0.15	0.38	0.25	0.26	0.05	0.07	0.10
012	3600	0.03	0.04	0.03	0.02	0.01	0.08	0.11	0.04	0.02	0.01	0.15	0.05	0.06	0.06	0.02	0.02	0.02
	4800	0.06	0.07	0.06	0.03	0.01	0.14	0.20	0.07	0.03	0.02	0.15	0.10	0.11	0.11	0.03	0.03	0.04
	6000	0.09	0.11	0.09	0.05	0.02	0.21	0.31	0.11	0.04	0.02	0.15	0.15	0.17	0.16	0.05	0.06	0.06
	7200	0.13	0.16	0.11	0.08	0.03	0.28	0.45	0.16	0.06	0.03	0.15	0.22	0.25	0.24	0.08	0.08	0.09
014	4200	0.03	0.04	0.03	0.02	0.01	0.08	0.11	0.04	0.02	0.01	0.15	0.08	0.06	0.05	0.02	0.02	0.02
	5400	0.06	0.07	0.05	0.03	0.01	0.13	0.19	0.07	0.03	0.02	0.15	0.13	0.10	0.09	0.03	0.03	0.04
	6600	0.08	0.10	0.08	0.05	0.02	0.19	0.28	0.10	0.04	0.02	0.15	0.20	0.15	0.13	0.04	0.05	0.06
	8800	0.15	0.18	0.12	0.08	0.04	0.31	0.50	0.18	0.07	0.04	0.15	0.35	0.26	0.23	0.08	0.09	0.11
017	5000	0.03	0.04	0.02	0.02	0.01	0.09	0.14	0.02	0.02	0.01	0.15	0.07	0.06	0.05	0.02	0.02	0.02
	6700	0.06	0.07	0.04	0.03	0.01	0.17	0.25	0.04	0.03	0.02	0.15	0.12	0.11	0.09	0.03	0.03	0.04
	8400	0.09	0.11	0.07	0.05	0.02	0.26	0.39	0.06	0.05	0.02	0.15	0.19	0.17	0.14	0.04	0.05	0.06
	10100	0.13	0.15	0.10	0.08	0.03	0.38	0.56	0.08	0.07	0.03	0.15	0.27	0.25	0.20	0.06	0.08	0.10
021	6000	0.03	0.04	0.02	0.02	0.01	0.13	0.19	0.04	0.01	0.01	0.15	0.06	0.07	0.05	0.02	0.02	0.02
	8000	0.05	0.06	0.03	0.03	0.01	0.23	0.34	0.07	0.03	0.01	0.15	0.11	0.12	0.09	0.03	0.03	0.04
	10000	0.08	0.10	0.05	0.04	0.02	0.36	0.53	0.11	0.04	0.02	0.15	0.17	0.18	0.14	0.05	0.05	0.07
	12000	0.12	0.14	0.07	0.06	0.03	0.52	0.76	0.15	0.06	0.03	0.15	0.25	0.27	0.21	0.07	0.08	0.10

\* Velocity exceeds 1000 fpm.

\*\* Blender data based on Blender Products IV.



**Table 8 continued: Component Pressure Drops (inches of water)**

Unit size	cfm	Dampers		F and BP face			F and BP by-pass			Plenum		Diffuser	Blender**			Attenuator		
		MXB	Econ.	Int. small	Int. med.	Large	Int. small	Int. med.	Large	Top/bot. inlet	Top/bot. outlet		One	Two	Three	3 ft	4 ft	5 ft
025	7300	0.03	0.04	0.02	0.02	0.01	0.07	0.10	0.05	0.02	0.01	0.15	0.06	0.05	0.06	0.02	0.02	0.02
	9800	0.06	0.07	0.04	0.03	0.01	0.13	0.17	0.08	0.03	0.01	0.15	0.12	0.10	0.10	0.03	0.04	0.05
	12200	0.09	0.11	0.06	0.05	0.02	0.21	0.27	0.13	0.05	0.02	0.15	0.18	0.15	0.16	0.05	0.06	0.07
	14600	0.13	0.15	0.09	0.07	0.02	0.30	0.38	0.18	0.07	0.03	0.15	0.26	0.22	0.22	0.07	0.09	0.11
030	8500	0.03	0.04	0.02	0.02	0.01	0.07	0.10	0.05	0.02	0.01	0.15	—	0.06	0.06	0.02	0.02	0.02
	11300	0.06	0.07	0.04	0.03	0.01	0.13	0.17	0.08	0.03	0.01	0.15	—	0.10	0.10	0.03	0.04	0.04
	14200	0.09	0.11	0.06	0.05	0.02	0.20	0.27	0.13	0.05	0.02	0.15	—	0.16	0.16	0.05	0.06	0.07
	17000	0.13	0.15	0.09	0.06	0.02	0.29	0.38	0.19	0.07	0.03	0.15	—	0.23	0.23	0.08	0.09	0.10
035	10000	0.03	0.04	0.02	0.02	0.01	0.08	0.10	0.05	0.02	0.01	0.15	—	0.07	0.06	0.02	0.02	0.02
	13400	0.06	0.07	0.03	0.03	0.01	0.15	0.17	0.09	0.03	0.02	0.15	—	0.12	0.11	0.04	0.04	0.04
	16700	0.09	0.10	0.05	0.05	0.02	0.23	0.27	0.14	0.05	0.02	0.15	—	0.18	0.16	0.06	0.06	0.07
	20000	0.13	0.15	0.06	0.07	0.02	0.33	0.38	0.20	0.07	0.03	0.15	—	0.26	0.24	0.08	0.09	0.11
040	12000	0.03	0.03	0.02	0.02	0.02	0.01	0.10	0.13	0.06	0.02	0.01	0.15	0.01	—	0.06	0.07	0.02
	16000	0.06	0.06	0.05	0.04	0.02	0.02	0.18	0.21	0.11	0.03	0.02	0.15	0.02	—	0.11	0.12	0.03
	20000	0.09	0.09	0.07	0.06	0.04	0.02	0.28	0.37	0.16	0.05	0.02	0.15	0.02	—	0.17	0.19	0.05
	24000	0.14	0.14	0.11	0.08	0.06	0.04	0.41	0.53	0.24	0.07	0.04	0.15	0.04	—	0.24	0.27	0.07
050	15000	0.04	0.04	0.03	0.02	0.01	0.01	0.08	0.21	0.05	0.02	0.01	0.15	0.01	—	0.07	0.06	0.02
	20000	0.07	0.07	0.04	0.04	0.02	0.01	0.15	0.37	0.09	0.04	0.02	0.15	0.02	—	0.12	0.11	0.05
	25000	0.11	0.11	0.07	0.06	0.04	0.02	0.23	0.58	0.14	0.06	0.02	0.15	0.02	—	0.18	0.18	0.08
	30000	0.15	0.15	0.10	0.09	0.05	0.03	0.33	0.84	0.21	0.08	0.03	0.15	0.03	—	0.26	0.26	0.11
065	19500	0.04	0.04	0.03	0.01	0.01	0.01	0.13	0.27	0.04	0.02	0.01	0.15	0.01	—	0.05	0.08	0.02
	26000	0.06	0.06	0.04	0.02	0.02	0.01	0.23	0.48	0.08	0.04	0.01	0.15	0.01	—	0.10	0.13	0.04
	32500	0.10	0.10	0.07	0.04	0.03	0.02	0.36	0.75	0.12	0.06	0.02	0.15	0.02	—	0.15	0.21	0.06
	39000	0.14	0.14	0.10	0.05	0.04	0.03	0.53	1.09	0.17	0.08	0.03	0.15	0.03	—	0.22	0.30	0.08
080	21500	0.03	0.03	—	0.02	0.01	0.01	0.09	0.16	0.04	0.02	0.01	0.15	0.01	—	0.07	0.10	0.02
	28700	0.05	0.05	—	0.03	0.02	0.01	0.17	0.29	0.08	0.03	0.01	0.15	0.01	—	0.12	0.17	0.04
	35900	0.08	0.08	—	0.05	0.04	0.02	0.26	0.45	0.12	0.05	0.02	0.15	0.02	—	0.19	0.27	0.07
	43100	0.11	0.11	—	0.07	0.05	0.03	0.37	0.65	0.18	0.07	0.03	0.15	0.03	—	0.28	0.38	0.10
085	23100	0.03	0.03	—	0.02	0.01	0.01	0.11	0.19	0.04	0.02	0.01	0.15	0.01	—	0.06	0.11	0.02
	30800	0.05	0.05	—	0.03	0.02	0.01	0.19	0.34	0.08	0.03	0.01	0.15	0.01	—	0.10	0.20	0.04
	38500	0.07	0.07	—	0.04	0.03	0.02	0.30	0.53	0.12	0.05	0.02	0.15	0.02	—	0.16	0.32	0.07
	46100	0.11	0.11	—	0.06	0.05	0.03	0.43	0.75	0.17	0.07	0.03	0.15	0.03	—	0.23	0.46	0.10
090	24600	0.03	0.03	—	0.01	0.01	0.01	0.13	0.22	0.04	0.02	0.01	0.15	0.01	—	0.07	0.13	0.02
	32800	0.05	0.05	—	0.02	0.02	0.01	0.22	0.39	0.08	0.03	0.01	0.15	0.01	—	0.12	0.24	0.04
	41000	0.08	0.08	—	0.04	0.03	0.02	0.35	0.60	0.12	0.05	0.02	0.15	0.02	—	0.19	0.37	0.07
	49200	0.11	0.11	—	0.06	0.04	0.03	0.50	0.87	0.17	0.07	0.03	0.15	0.03	—	0.27	—	0.10

\* Velocity exceeds 1000 fpm.

\*\* Blender data based on Blender Products IV.

**Table 7: Filter Media Face Areas and Velocity Through Media**

Unit size	cfm	Filter face areas (sq ft) and velocities (fpm)													
		2" throwaway (TA)		2" angular		4" angular		12" cartridge		4" cartridge		12" mini-pleat		Bag	
		Area	Vel	Area	Vel	Area	Vel	Area	Vel	Area	Vel	Area	Vel	Area	Vel
003	900	3.2	281	10.1	89	N/A	N/A	3.1	290	3.1	290	3.1	290	3.1	290
	1200	3.2	375	10.1	119	N/A	N/A	3.1	387	3.1	387	3.1	387	3.1	387
	1500	3.2	469	10.1	149	N/A	N/A	3.1	484	3.1	484	3.1	484	3.1	484
	1800	3.2	563	10.1	178	N/A	N/A	3.1	581	3.1	581	3.1	581	3.1	581
004	1200	5.7	211	11.4	105	N/A	N/A	5.6	214	5.6	214	5.6	214	5.6	214
	1600	5.7	281	11.4	140	N/A	N/A	5.6	286	5.6	286	5.6	286	5.6	286
	2000	5.7	351	11.4	175	N/A	N/A	5.6	357	5.6	357	5.6	357	5.6	357
	2400	5.7	421	11.4	211	N/A	N/A	5.6	429	5.6	429	5.6	429	5.6	429
006	1700	7.6	224	15.3	111	N/A	N/A	7.6	224	7.6	224	7.6	224	7.6	224
	2300	7.6	303	15.3	150	N/A	N/A	7.6	303	7.6	303	7.6	303	7.6	303
	2900	7.6	382	15.3	190	N/A	N/A	7.6	382	7.6	382	7.6	382	7.6	382
	3500	7.6	461	15.3	229	N/A	N/A	7.6	461	7.6	461	7.6	461	7.6	461
008	2200	8.8	250	17.7	124	17.7	124	8.1	272	8.1	272	8.1	272	8.1	272
	3000	8.8	341	17.7	169	17.7	169	8.1	370	8.1	370	8.1	370	8.1	370
	3800	8.8	432	17.7	215	17.7	215	8.1	469	8.1	469	8.1	469	8.1	469
	4600	8.8	523	17.7	260	17.7	260	8.1	568	8.1	568	8.1	568	8.1	568
010	2900	10.0	289	19.0	153	19.0	153	10.0	290	10.0	290	10.0	290	10.0	290
	3900	10.0	389	19.0	205	19.0	205	10.0	391	10.0	391	10.0	391	10.0	391
	4900	10.0	489	19.0	258	19.0	258	10.0	491	10.0	491	10.0	491	10.0	491
	5900	10.0	589	19.0	311	19.0	311	10.0	591	10.0	591	10.0	591	10.0	591
012	3600	13.2	273	30.3	119	20.3	177	13.1	275	13.1	275	13.1	275	13.1	275
	4800	13.2	364	30.3	159	20.3	236	13.1	366	13.1	366	13.1	366	13.1	366
	6000	13.2	455	30.3	198	20.3	296	13.1	458	13.1	458	13.1	458	13.1	458
	7200	13.2	545	30.3	238	20.3	355	13.1	550	13.1	550	13.1	550	13.1	550
014	4200	17.0	247	34.1	123	22.9	183	14.4	292	14.4	292	14.4	292	14.4	292
	5400	17.0	318	34.1	158	22.9	236	14.4	375	14.4	375	14.4	375	14.4	375
	6600	17.0	388	34.1	193	22.9	288	14.4	458	14.4	458	14.4	458	14.4	458
	8800	17.0	518	34.1	258	22.9	384	14.4	611	14.4	611	14.4	611	14.4	611
017	5000	19.0	263	35.7	140	36.0	139	18.9	265	18.9	265	18.9	265	18.9	265
	6700	19.0	353	36.0	186	36.0	186	18.9	354	18.9	354	18.9	354	18.9	354
	8400	19.0	442	36.0	233	36.0	233	18.9	444	18.9	444	18.9	444	18.9	444
	10100	19.0	532	36.0	281	36.0	281	18.9	534	18.9	534	18.9	534	18.9	534
021	6000	23.2	259	38.0	158	38.0	158	23.0	261	23.0	261	20.8	288	23.0	281
	8000	23.2	345	38.0	211	38.0	211	23.0	348	23.0	348	20.8	385	23.0	348
	10000	23.2	431	38.0	263	38.0	263	23.0	435	23.0	435	20.8	481	23.0	435
	12000	23.2	517	38.0	316	38.0	316	23.0	522	23.0	522	20.8	577	23.0	522
025	7300	26.6	274	39.9	183	39.9	183	26.5	275	26.5	275	26.5	275	26.5	275
	9800	26.6	368	39.9	246	39.9	246	26.5	370	26.5	370	26.5	370	26.5	370
	12200	26.6	459	39.9	306	39.9	306	26.5	460	26.5	460	26.5	460	26.5	460
	14600	26.6	549	39.9	366	39.9	366	26.5	551	26.5	551	26.5	551	26.5	551

Note: 400 fpm maximum for angular filters.

**Table 9 continued: Filter Media Face Areas and Velocity Through Media**

Unit size	cfm	Filter face areas (sq ft) and velocities (fpm)													
		2" throwaway (TA)		2" angular		4" angular		12" cartridge		4" cartridge		12" mini-pleat		Bag	
		Area	Vel	Area	Vel	Area	Vel	Area	Vel	Area	Vel	Area	Vel	Area	Vel
030	8500	32.8	269	45.8	186	45.8	186	32.6	261	32.6	261	32.6	261	32.6	261
	11300	32.8	345	45.8	247	45.8	247	32.6	347	32.6	347	32.6	347	32.6	347
	14200	32.8	433	45.8	310	45.8	310	32.6	436	32.6	436	32.6	436	32.6	436
	17000	32.8	578	45.8	371	45.8	371	32.6	521	32.6	521	32.6	521	32.6	521
035	10000	39.4	254	63.3	158	63.3	158	39.1	256	39.1	256	37.7	265	39.1	256
	13400	39.4	340	63.3	212	63.3	212	39.1	343	39.1	343	37.7	355	39.1	343
	16700	39.4	424	63.3	264	63.3	264	39.1	427	39.1	427	37.7	443	39.1	427
	20000	39.4	508	63.3	316	63.3	316	39.1	512	39.1	512	37.7	531	39.1	512
040	12000	44.2	271	71.1	169	71.1	169	44.0	273	44.0	273	44.0	273	44.0	273
	16000	44.2	362	71.1	225	71.1	225	44.0	364	44.0	364	44.0	364	44.0	364
	20000	44.2	452	71.1	281	71.1	281	44.0	455	44.0	455	44.0	455	44.0	455
	24000	44.2	543	71.1	338	71.1	338	44.0	545	44.0	545	44.0	545	44.0	545
050	15000	55.3	271	73.7	2.4	73.7	204	55.0	273	55.0	273	55.0	273	55.0	273
	20000	55.3	362	73.7	271	73.7	271	55.0	364	55.0	364	55.0	364	55.0	364
	25000	55.3	452	73.7	339	73.7	339	55.0	455	55.0	455	55.0	455	55.0	455
	30000	55.3	542	73.7	407	73.7	407	55.0	545	55.0	545	55.0	545	55.0	545
065	19500	72.1	270	107.5	181	107.5	181	71.7	272	71.7	272	71.7	272	71.7	272
	26000	72.1	361	107.5	242	107.5	242	71.7	363	71.7	363	71.7	363	71.7	363
	32500	72.1	451	107.5	302	107.5	302	71.7	453	71.7	453	71.7	453	71.7	453
	39000	72.1	541	107.5	363	107.5	363	71.7	544	71.7	544	71.7	544	71.7	544
080	21500	80.2	268	107.5	200	107.5	200	78.2	275	79.7	270	78.2	275	79.7	270
	28700	80.2	358	107.5	267	107.5	267	78.2	367	79.7	360	78.2	367	79.7	360
	35900	80.2	448	107.5	334	107.5	334	78.2	459	79.7	450	78.2	459	79.7	450
	43100	80.2	538	107.5	401	107.5	401	78.2	551	79.7	541	78.2	551	79.7	541
085	23100	86.0	269	129.0	179	107.5	215	83.3	277	83.3	277	83.3	277	83.3	277
	30800	86.0	358	129.0	239	107.5	287	83.3	370	83.3	370	83.3	370	83.3	370
	38500	86.0	448	129.0	298	107.5	359	83.3	462	83.3	462	83.3	462	83.3	462
	46100	86.0	536	129.0	358	129.0	358	83.3	553	83.3	554	83.3	554	83.3	554
090	24600	90.4	272	129.0	191	129.0	191	86.3	285	89.8	274	87.4	281	89.8	274
	32800	90.4	363	129.0	254	129.0	254	86.3	380	89.8	365	87.4	375	89.8	365
	41000	90.4	454	129.0	318	129.0	318	86.3	475	89.8	456	87.4	469	89.8	456
	49200	90.4	544	129.0	381	129.0	381	86.3	570	89.8	548	87.4	563	89.8	548

Note: 400 fpm maximum for angular filters.

**Table 8: Filter Media Air Pressure Drop Based on Clean Filters—Flat and Angular Panel, High Efficiency Cartridge**

Unit size	cfm	Flat panel					Angular panel					High efficiency cartridge								
		T.A.	Pleated (30%)		Pleated (70%)		T.A.	Pleated (30%)		Pleated (70%)		Cartridge			Mini-pleat cartridge			Mini-pleat cartridge		
		2"	30%	4"	70%	70%	2"	30%	4"	70%	70%	12"			4"			12"		
		N/A	30%	30%	70%	70%	N/A	30%	30%	70%	70%	65%	85%	95%	65%	85%	95%	65%	85%	95%
003	900	0.11	0.12	0.11	0.15	0.12	0.02	0.01	—	0.03	—	0.18	0.25	0.26	0.18	0.31	0.36	0.10	0.13	0.22
	1200	0.17	0.19	0.16	0.21	0.18	0.03	0.02	—	0.05	—	0.27	0.38	0.40	0.28	0.44	0.51	0.18	0.22	0.34
	1500	0.23	0.27	0.23	0.29	0.25	0.04	0.03	—	0.06	—	0.37	0.53	0.55	0.40	0.58	0.66	0.27	0.34	0.47
	1800	0.30	0.37	0.31	0.37	0.33	0.05	0.04	—	0.08	—	0.48	0.70	0.72	0.53	0.72	0.82	0.39	0.47	0.61
004	1200	0.07	0.07	0.07	0.10	0.08	0.03	0.02	—	0.04	—	0.12	0.16	0.16	0.11	0.22	0.26	0.06	0.08	0.14
	1600	0.11	0.11	0.10	0.15	0.12	0.04	0.04	—	0.06	—	0.18	0.25	0.25	0.18	0.31	0.36	0.10	0.13	0.22
	2000	0.15	0.17	0.15	0.20	0.17	0.06	0.05	—	0.08	—	0.24	0.34	0.35	0.25	0.40	0.47	0.15	0.19	0.30
	2400	0.20	0.23	0.20	0.25	0.22	0.07	0.07	—	0.10	—	0.31	0.45	0.46	0.33	0.50	0.58	0.22	0.27	0.39
006	1700	0.08	0.08	0.07	0.11	0.09	0.03	0.02	—	0.04	—	0.12	0.17	0.17	0.12	0.23	0.27	0.06	0.08	0.15
	2300	0.12	0.13	0.12	0.16	0.13	0.04	0.04	—	0.06	—	0.19	0.27	0.27	0.20	0.33	0.39	0.11	0.14	0.23
	2900	0.17	0.19	0.17	0.22	0.18	0.06	0.06	—	0.09	—	0.26	0.38	0.39	0.28	0.44	0.51	0.17	0.22	0.33
	3500	0.22	0.26	0.22	0.28	0.24	0.08	0.08	—	0.11	—	0.35	0.50	0.51	0.38	0.55	0.64	0.25	0.31	0.43
008	2200	0.09	0.09	0.09	0.12	0.10	0.03	0.03	0.03	0.05	0.04	0.15	0.21	0.21	0.17	0.29	0.34	0.08	0.10	0.18
	3000	0.14	0.16	0.14	0.19	0.16	0.05	0.05	0.05	0.07	0.06	0.23	0.32	0.33	0.27	0.42	0.49	0.14	0.18	0.28
	3800	0.20	0.24	0.20	0.25	0.22	0.07	0.07	0.07	0.10	0.08	0.32	0.46	0.47	0.39	0.56	0.65	0.22	0.28	0.40
	4600	0.27	0.33	0.27	0.33	0.29	0.10	0.10	0.09	0.13	0.11	0.42	0.61	0.63	0.52	0.71	0.81	0.32	0.40	0.53
010	2900	0.12	0.13	0.12	0.16	0.14	0.05	0.04	0.04	0.07	0.05	0.20	0.28	0.28	0.20	0.34	0.40	0.11	0.15	0.24
	3900	0.19	0.22	0.19	0.24	0.21	0.07	0.07	0.06	0.10	0.08	0.30	0.43	0.44	0.32	0.48	0.56	0.20	0.26	0.37
	4900	0.26	0.32	0.27	0.32	0.28	0.10	0.10	0.09	0.13	0.11	0.41	0.60	0.62	0.46	0.64	0.73	0.31	0.39	0.52
	5900	0.34	0.44	0.36	0.41	0.37	0.13	0.14	0.12	0.17	0.14	0.54	0.78	0.81	0.61	0.80	0.91	0.45	0.55	0.68
012	3600	0.13	0.14	0.13	0.14	0.12	0.06	0.05	0.05	0.08	0.06	0.17	0.23	0.24	0.17	0.29	0.35	0.09	0.12	0.20
	4800	0.20	0.23	0.20	0.20	0.17	0.09	0.09	0.08	0.12	0.09	0.25	0.35	0.36	0.26	0.42	0.49	0.16	0.20	0.31
	6000	0.27	0.33	0.28	0.27	0.24	0.12	0.13	0.11	0.16	0.13	0.34	0.49	0.51	0.37	0.55	0.63	0.25	0.31	0.43
	7200	—	—	—	0.35	0.31	0.15	0.17	0.15	0.20	0.17	0.45	0.64	0.67	0.50	0.68	0.78	0.35	0.43	0.56
014	4200	0.09	0.09	0.09	0.12	0.10	0.06	0.06	0.05	0.08	0.07	0.17	0.24	0.24	0.19	0.32	0.37	0.10	0.12	0.21
	5400	0.13	0.14	0.13	0.17	0.14	0.08	0.09	0.08	0.12	0.09	0.24	0.35	0.36	0.27	0.43	0.50	0.15	0.20	0.30
	6600	0.17	0.20	0.17	0.22	0.19	0.11	0.12	0.11	0.15	0.13	0.32	0.46	0.48	0.37	0.55	0.63	0.23	0.28	0.41
	8800	0.26	0.32	0.27	0.32	0.29	0.17	0.19	0.17	0.22	0.19	0.41	0.59	0.61	0.59	0.78	0.88	0.39	0.48	0.62
017	5000	0.10	0.10	0.10	0.13	0.11	0.04	0.04	0.04	0.06	0.04	0.16	0.22	0.22	0.16	0.28	0.33	0.09	0.11	0.19
	6700	0.15	0.17	0.15	0.20	0.17	0.06	0.06	0.06	0.08	0.07	0.24	0.34	0.35	0.25	0.40	0.47	0.15	0.19	0.30
	8400	0.21	0.25	0.21	0.26	0.23	0.08	0.08	0.08	0.11	0.09	0.33	0.47	0.49	0.36	0.53	0.61	0.23	0.29	0.41
	10100	0.27	0.34	0.28	0.33	0.30	0.11	0.11	0.11	0.14	0.12	0.43	0.62	0.64	0.48	0.66	0.76	0.33	0.41	0.54
021	6000	0.10	0.10	0.09	0.13	0.11	0.05	0.04	0.04	0.07	0.05	0.15	0.22	0.22	0.16	0.28	0.33	0.10	0.13	0.22
	8000	0.15	0.16	0.14	0.19	0.16	0.07	0.07	0.07	0.10	0.08	0.23	0.33	0.34	0.24	0.39	0.46	0.18	0.22	0.33
	10000	0.20	0.24	0.20	0.25	0.22	0.10	0.10	0.10	0.13	0.11	0.32	0.46	0.47	0.35	0.51	0.59	0.27	0.33	0.46
	12000	0.26	0.32	0.27	0.32	0.29	0.13	0.14	0.13	0.17	0.14	0.41	0.60	0.62	0.46	0.64	0.74	0.38	0.47	0.60

**Table 10 continued: Filter Media Air Pressure Drop Based on Clean Filters—Flat and Angular Panel, High Efficiency Cartridge**

Unit size	cfm	Flat panel Angular panel High efficiency cartridge																				
		T.A.		Pleated (30%)		Pleated (70%)		T.A.		Pleated (30%)		Pleated (70%)		Cartridge			Mini-pleat cartridge			Mini-pleat cartridge		
		2"	4"	2"	4"	2"	4"	2"	4"	2"	4"	12"			4"			12"				
		N/A	30%	30%	70%	70%	N/A	30%	30%	70%	70%	65%	85%	95%	65%	85%	95%	65%	85%	95%		
025	7300	0.11	0.11	0.10	0.14	0.12	0.06	0.06	0.05	0.08	0.07	0.17	0.23	0.24	0.17	0.30	0.35	0.09	0.12	0.20		
	9800	0.16	0.18	0.16	0.21	0.18	0.09	0.09	0.09	0.12	0.10	0.25	0.36	0.37	0.27	0.42	0.49	0.16	0.21	0.31		
	12200	0.22	0.26	0.22	0.28	0.24	0.12	0.13	0.12	0.16	0.14	0.35	0.50	0.51	0.38	0.55	0.64	0.25	0.31	0.43		
	14600	0.29	0.35	0.29	0.35	0.31	0.16	0.18	0.16	0.20	0.18	0.45	0.65	0.67	0.50	0.69	0.79	0.35	0.43	0.57		
030	8500	0.10	0.10	0.09	0.13	0.11	0.06	0.06	0.06	0.08	0.07	0.15	0.22	0.22	0.16	0.28	0.33	0.08	0.11	0.19		
	11300	0.15	0.16	0.14	0.19	0.16	0.09	0.09	0.09	0.12	0.10	0.23	0.33	0.34	0.24	0.39	0.46	0.14	0.18	0.29		
	14200	0.20	0.24	0.20	0.26	0.22	0.13	0.14	0.12	0.16	0.14	0.32	0.46	0.47	0.35	0.52	0.60	0.22	0.28	0.40		
035	17000	0.26	0.32	0.27	0.32	0.29	0.16	0.18	0.16	0.21	0.18	0.41	0.60	0.62	0.46	0.64	0.74	0.32	0.39	0.52		
	10000	0.09	0.10	0.09	0.13	0.10	0.05	0.04	0.04	0.07	0.05	0.15	0.21	0.21	0.15	0.27	0.32	0.09	0.11	0.19		
	13400	0.14	0.16	0.14	0.19	0.16	0.07	0.07	0.07	0.10	0.08	0.23	0.32	0.33	0.24	0.39	0.45	0.15	0.19	0.30		
	16700	0.20	0.23	0.20	0.25	0.22	0.10	0.10	0.10	0.13	0.11	0.31	0.44	0.46	0.34	0.50	0.58	0.23	0.29	0.41		
040	20000	0.26	0.31	0.26	0.32	0.28	0.13	0.14	0.13	0.17	0.14	0.40	0.58	0.60	0.45	0.63	0.72	0.32	0.40	0.53		
	12000	0.10	0.11	0.10	0.14	0.12	0.05	0.05	0.05	0.07	0.06	0.16	0.23	0.24	0.17	0.29	0.34	0.12	0.16	0.25		
	16000	0.16	0.18	0.16	0.20	0.17	0.08	0.08	0.07	0.10	0.08	0.25	0.35	0.36	0.26	0.42	0.48	0.21	0.27	0.39		
	20000	0.22	0.26	0.22	0.27	0.24	0.11	0.11	0.10	0.14	0.12	0.34	0.49	0.50	0.37	0.54	0.63	0.32	0.40	0.53		
050	24000	0.28	0.35	0.29	0.34	0.31	0.14	0.15	0.13	0.18	0.15	0.44	0.64	0.66	0.49	0.68	0.78	0.46	0.56	0.70		
	15000	0.10	0.10	0.10	0.13	0.11	0.07	0.06	0.06	0.09	0.07	0.16	0.22	0.23	0.17	0.29	0.34	0.09	0.11	0.20		
	20000	0.15	0.17	0.15	0.19	0.17	0.10	0.10	0.10	0.13	0.11	0.24	0.34	0.35	0.26	0.42	0.48	0.15	0.19	0.30		
	25000	0.21	0.24	0.21	0.26	0.23	0.14	0.15	0.14	0.18	0.15	0.33	0.47	0.49	0.37	0.54	0.63	0.23	0.29	0.41		
065	30000	0.27	0.33	0.28	0.33	0.29	0.18	0.21	0.18	0.23	0.20	0.43	0.62	0.64	0.49	0.68	0.78	0.33	0.41	0.54		
	19500	0.11	0.11	0.10	0.13	0.11	0.06	0.06	0.05	0.08	0.06	0.17	0.24	0.25	0.16	0.29	0.34	0.11	0.14	0.23		
	26000	0.16	0.19	0.16	0.19	0.16	0.09	0.09	0.08	0.12	0.10	0.26	0.37	0.38	0.26	0.41	0.47	0.18	0.23	0.34		
	32500	0.23	0.27	0.23	0.25	0.22	0.12	0.13	0.12	0.16	0.13	0.36	0.51	0.53	0.36	0.53	0.62	0.28	0.35	0.48		
080	39000	0.30	0.37	0.30	0.32	0.29	0.16	0.18	0.16	0.20	0.17	0.46	0.67	0.70	0.48	0.67	0.76	0.40	0.49	0.62		
	21500	0.10	0.06	0.09	0.13	0.11	0.07	0.04	0.06	0.09	0.07	0.17	0.23	0.24	0.17	0.29	0.34	0.09	0.12	0.20		
	28700	0.15	0.10	0.15	0.19	0.16	0.10	0.06	0.10	0.13	0.11	0.25	0.36	0.37	0.26	0.41	0.48	0.16	0.20	0.31		
	35900	0.21	0.15	0.21	0.26	0.22	0.14	0.09	0.14	0.18	0.15	0.35	0.49	0.51	0.37	0.54	0.62	0.25	0.31	0.43		
085	43100	0.28	0.20	0.27	0.33	0.29	0.18	0.13	0.18	0.23	0.20	0.45	0.65	0.67	0.49	0.67	0.77	0.35	0.43	0.57		
	23100	0.10	0.06	0.10	0.14	0.11	0.06	0.03	0.07	0.08	0.08	0.17	0.24	0.24	0.17	0.30	0.35	0.09	0.12	0.21		
	30800	0.15	0.10	0.15	0.20	0.17	0.09	0.05	0.11	0.12	0.12	0.25	0.36	0.37	0.27	0.42	0.49	0.16	0.21	0.31		
	38500	0.21	0.15	0.22	0.27	0.23	0.12	0.07	0.15	0.16	0.17	0.35	0.50	0.52	0.38	0.55	0.64	0.25	0.31	0.44		
090	46100	0.28	0.21	0.28	0.34	0.30	0.15	0.10	0.15	0.20	0.17	0.45	0.65	0.67	0.50	0.69	0.79	0.35	0.43	0.57		
	24600	0.10	0.06	0.10	0.13	0.11	0.06	0.03	0.06	0.09	0.07	0.17	0.25	0.25	0.17	0.29	0.35	0.10	0.13	0.21		
	32800	0.16	0.10	0.15	0.19	0.17	0.09	0.06	0.09	0.13	0.10	0.26	0.37	0.39	0.26	0.42	0.48	0.17	0.21	0.32		
	41000	0.22	0.15	0.21	0.26	0.23	0.13	0.08	0.13	0.17	0.14	0.36	0.52	0.54	0.37	0.55	0.63	0.26	0.32	0.45		
49200	0.28	0.21	0.28	0.33	0.29	0.17	0.12	0.17	0.22	0.18	0.47	0.68	0.71	0.50	0.68	0.78	0.36	0.45	0.58			

**Table 9: Filter Media Air Pressure Drop Based on Clean Filters—High Efficiency Bag**

Unit size	cfm	High efficiency bag											
		DriPak 2000											
		36"			30"			22"			19"	15"	12"
		65%	85%	95%	65%	85%	95%	65%	85%	95%	45%	45%	45%
003	900	0.15	0.22	0.29	0.15	0.21	0.32	0.17	0.28	0.42	0.11	0.10	0.13
	1200	0.20	0.29	0.39	0.19	0.29	0.43	0.23	0.37	0.56	0.18	0.14	0.17
	1500	0.24	0.36	0.49	0.24	0.36	0.53	0.28	0.46	0.70	0.25	0.19	0.21
	1800	0.29	0.43	0.59	0.29	0.43	0.64	0.33	0.56	0.83	0.33	0.24	0.25
004	1200	0.11	0.16	0.21	0.11	0.16	0.24	0.13	0.21	0.32	0.07	0.07	0.10
	1600	0.15	0.21	0.29	0.14	0.21	0.31	0.17	0.27	0.42	0.11	0.10	0.13
	2000	0.18	0.27	0.36	0.18	0.26	0.39	0.21	0.34	0.52	0.16	0.13	0.16
	2400	0.22	0.32	0.44	0.21	0.32	0.47	0.25	0.41	0.62	0.21	0.16	0.19
006	1700	0.12	0.17	0.22	0.11	0.17	0.25	0.14	0.21	0.33	0.08	0.07	0.11
	2300	0.15	0.23	0.31	0.15	0.22	0.33	0.18	0.29	0.44	0.12	0.11	0.14
	2900	0.19	0.28	0.39	0.19	0.28	0.42	0.22	0.37	0.55	0.17	0.14	0.17
	3500	0.23	0.34	0.47	0.23	0.34	0.51	0.27	0.44	0.66	0.23	0.18	0.20
008	2200	0.13	0.19	0.25	0.13	0.19	0.28	0.15	0.24	0.37	0.09	0.08	0.12
	3000	0.17	0.26	0.35	0.17	0.26	0.38	0.20	0.33	0.50	0.15	0.13	0.16
	3800	0.22	0.32	0.44	0.22	0.32	0.48	0.26	0.42	0.63	0.21	0.17	0.19
	4600	0.26	0.39	0.54	0.26	0.39	0.58	0.31	0.51	0.76	0.28	0.21	0.23
010	2900	0.16	0.23	0.31	0.15	0.23	0.34	0.18	0.30	0.45	0.13	0.11	0.14
	3900	0.21	0.31	0.42	0.21	0.31	0.46	0.24	0.40	0.60	0.20	0.16	0.19
	4900	0.26	0.39	0.53	0.26	0.39	0.57	0.30	0.50	0.75	0.28	0.21	0.23
	5900	—	—	—	—	—	—	—	—	—	—	—	—
012	3600	0.14	0.21	0.28	0.14	0.20	0.30	0.16	0.26	0.40	0.11	0.09	0.13
	4800	0.19	0.27	0.37	0.18	0.27	0.40	0.22	0.35	0.53	0.16	0.14	0.17
	6000	0.23	0.34	0.47	0.23	0.34	0.50	0.27	0.44	0.66	0.23	0.18	0.20
	7200	0.27	0.41	0.56	0.27	0.41	0.60	0.32	0.53	0.79	0.30	0.23	0.24
014	4200	0.14	0.21	0.28	0.14	0.21	0.31	0.17	0.27	0.41	0.11	0.10	0.13
	5400	0.18	0.27	0.36	0.18	0.27	0.40	0.21	0.35	0.52	0.16	0.13	0.16
	6600	0.22	0.33	0.45	0.22	0.33	0.48	0.26	0.42	0.64	0.21	0.17	0.20
	8800	0.29	0.43	0.60	0.29	0.43	0.65	0.34	0.56	0.84	0.33	0.24	0.25
017	5000	0.14	0.20	0.27	0.13	0.20	0.29	0.16	0.25	0.39	0.10	0.09	0.12
	6700	0.18	0.26	0.36	0.18	0.26	0.39	0.21	0.34	0.52	0.15	0.13	0.16
	8400	0.22	0.33	0.45	0.22	0.33	0.49	0.26	0.43	0.64	0.22	0.17	0.20
	10100	0.27	0.39	0.55	0.27	0.40	0.59	0.31	0.51	0.77	0.29	0.22	0.23
021	6000	0.13	0.20	0.26	0.13	0.19	0.29	0.16	0.25	0.38	0.10	0.09	0.12
	8000	0.18	0.26	0.35	0.17	0.26	0.38	0.21	0.33	0.51	0.15	0.13	0.16
	10000	0.22	0.32	0.44	0.22	0.32	0.48	0.25	0.42	0.63	0.21	0.17	0.19
	12000	0.26	0.39	0.53	0.26	0.39	0.57	0.30	0.50	0.75	0.28	0.21	0.23
025	7300	0.14	0.21	0.28	0.14	0.20	0.30	0.16	0.26	0.40	0.11	0.09	0.13
	9800	0.19	0.28	0.37	0.18	0.27	0.41	0.22	0.36	0.54	0.16	0.14	0.17
	12200	0.23	0.34	0.47	0.23	0.34	0.51	0.27	0.44	0.66	0.23	0.18	0.20
	14600	0.27	0.41	0.56	0.28	0.41	0.61	0.32	0.53	0.79	0.30	0.23	0.24



**Table 11 continued: Filter Media Air Pressure Drop Based on Clean Filters—High Efficiency Bag**

Unit size	cfm	High efficiency bag											
		DriPak 2000											
		36"			30"			22"			19"	15"	12"
		65%	85%	95%	65%	85%	95%	65%	85%	95%	45%	45%	45%
030	8500	0.13	0.20	0.26	0.13	0.19	0.29	0.16	0.25	0.38	0.10	0.09	0.12
	11300	0.18	0.26	0.35	0.17	0.26	0.38	0.21	0.33	0.51	0.15	0.13	0.16
	14200	0.22	0.32	0.44	0.22	0.32	0.48	0.26	0.42	0.63	0.21	0.17	0.19
	17000	0.26	0.39	0.53	0.26	0.39	0.58	0.30	0.50	0.75	0.28	0.21	0.23
035	10000	0.13	0.19	0.26	0.13	0.19	0.28	0.15	0.25	0.38	0.09	0.09	0.12
	13400	0.17	0.26	0.35	0.17	0.25	0.38	0.20	0.33	0.50	0.15	0.12	0.16
	16700	0.21	0.32	0.43	0.21	0.32	0.47	0.25	0.41	0.62	0.20	0.16	0.19
	20000	0.26	0.38	0.52	0.26	0.38	0.56	0.30	0.49	0.74	0.27	0.21	0.22
040	12000	0.14	0.20	0.28	0.14	0.20	0.30	0.16	0.26	0.40	0.10	0.09	0.13
	16000	0.18	0.27	0.37	0.18	0.27	0.40	0.21	0.35	0.53	0.16	0.13	0.17
	20000	0.23	0.34	0.46	0.23	0.34	0.50	0.27	0.44	0.66	0.23	0.18	0.20
	24000	0.27	0.40	0.56	0.27	0.40	0.60	0.32	0.52	0.79	0.30	0.22	0.24
050	15000	0.14	0.20	0.27	0.13	0.20	0.29	0.16	0.26	0.39	0.10	0.09	0.13
	20000	0.18	0.27	0.36	0.18	0.26	0.39	0.21	0.34	0.52	0.16	0.13	0.16
	25000	0.22	0.33	0.45	0.22	0.33	0.49	0.26	0.43	0.65	0.22	0.17	0.20
	30000	0.27	0.40	0.55	0.27	0.40	0.59	0.31	0.51	0.77	0.29	0.22	0.23
065	19500	0.14	0.21	0.28	0.14	0.21	0.31	0.17	0.27	0.41	0.11	0.10	0.13
	26000	0.19	0.28	0.38	0.19	0.28	0.41	0.22	0.36	0.55	0.17	0.14	0.17
	32500	0.24	0.35	0.48	0.24	0.35	0.52	0.27	0.45	0.68	0.24	0.19	0.21
	39000	0.28	0.42	0.58	0.28	0.42	0.62	0.33	0.54	0.81	0.31	0.23	0.25
080	21500	0.12	0.16	0.23	0.15	0.19	0.27	0.17	0.26	0.38	0.07	0.09	0.13
	28700	0.15	0.21	0.31	0.19	0.26	0.36	0.22	0.35	0.51	0.11	0.13	0.16
	35900	0.19	0.26	0.39	0.24	0.32	0.45	0.27	0.43	0.63	0.16	0.18	0.20
	43100	0.23	0.31	0.47	0.28	0.39	0.54	0.32	0.52	0.76	0.21	0.22	0.24
085	23100	0.12	0.16	0.23	0.15	0.20	0.28	0.17	0.27	0.40	0.08	0.10	0.13
	30800	0.16	0.22	0.32	0.20	0.27	0.37	0.23	0.36	0.52	0.12	0.14	0.17
	38500	0.19	0.27	0.40	0.24	0.33	0.46	0.28	0.44	0.65	0.16	0.18	0.21
	46100	0.23	0.32	0.48	0.29	0.40	0.55	0.33	0.53	0.77	0.22	0.23	0.24
090	24600	0.12	0.16	0.23	0.15	0.20	0.28	0.17	0.26	0.39	0.07	0.09	0.13
	32800	0.16	0.21	0.31	0.20	0.26	0.37	0.22	0.35	0.52	0.12	0.13	0.17
	41000	0.19	0.27	0.39	0.24	0.33	0.46	0.28	0.44	0.64	0.16	0.18	0.20
	49200	0.23	0.32	0.47	0.28	0.39	0.55	0.33	0.53	0.76	0.21	0.22	0.24

Figure 22: Coil Air Pressure Drop—HI-F5 Fin Type (2 Through 12 Rows)

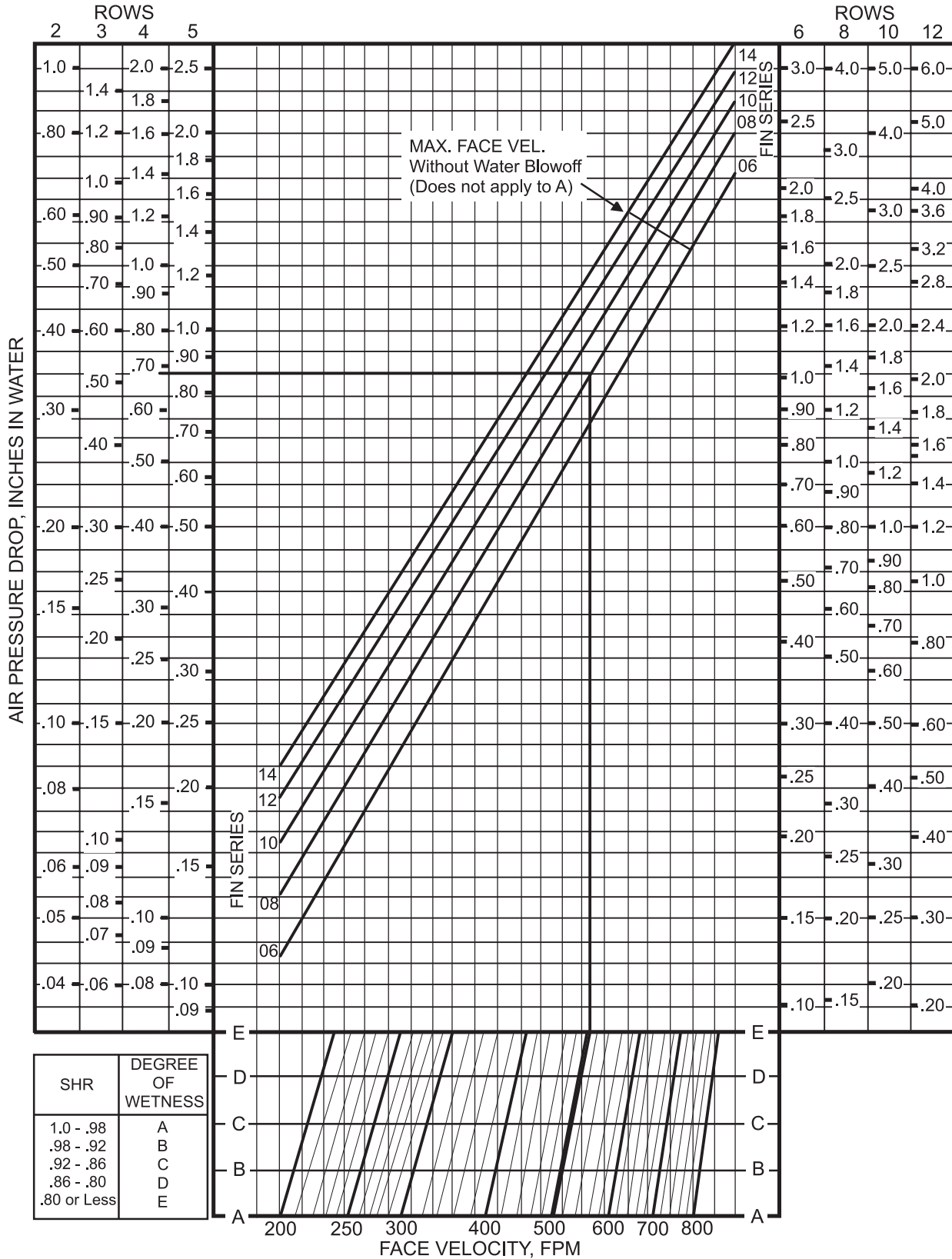

- Notes:
- The letters A,B,C,D or E following the face velocity indicate the degree of wetness at which the coil is operating.
  - Dry coils are shown by the letter A, wet coils by the letter E. Intermediate conditions are shown by the letters B, C, and D.
  - Air pressure drop for odd fin spacings can be found by interpolation.

Figure 23: Coil Air Pressure Drop—E-F5 Fin Type (2 Through 12 Rows)

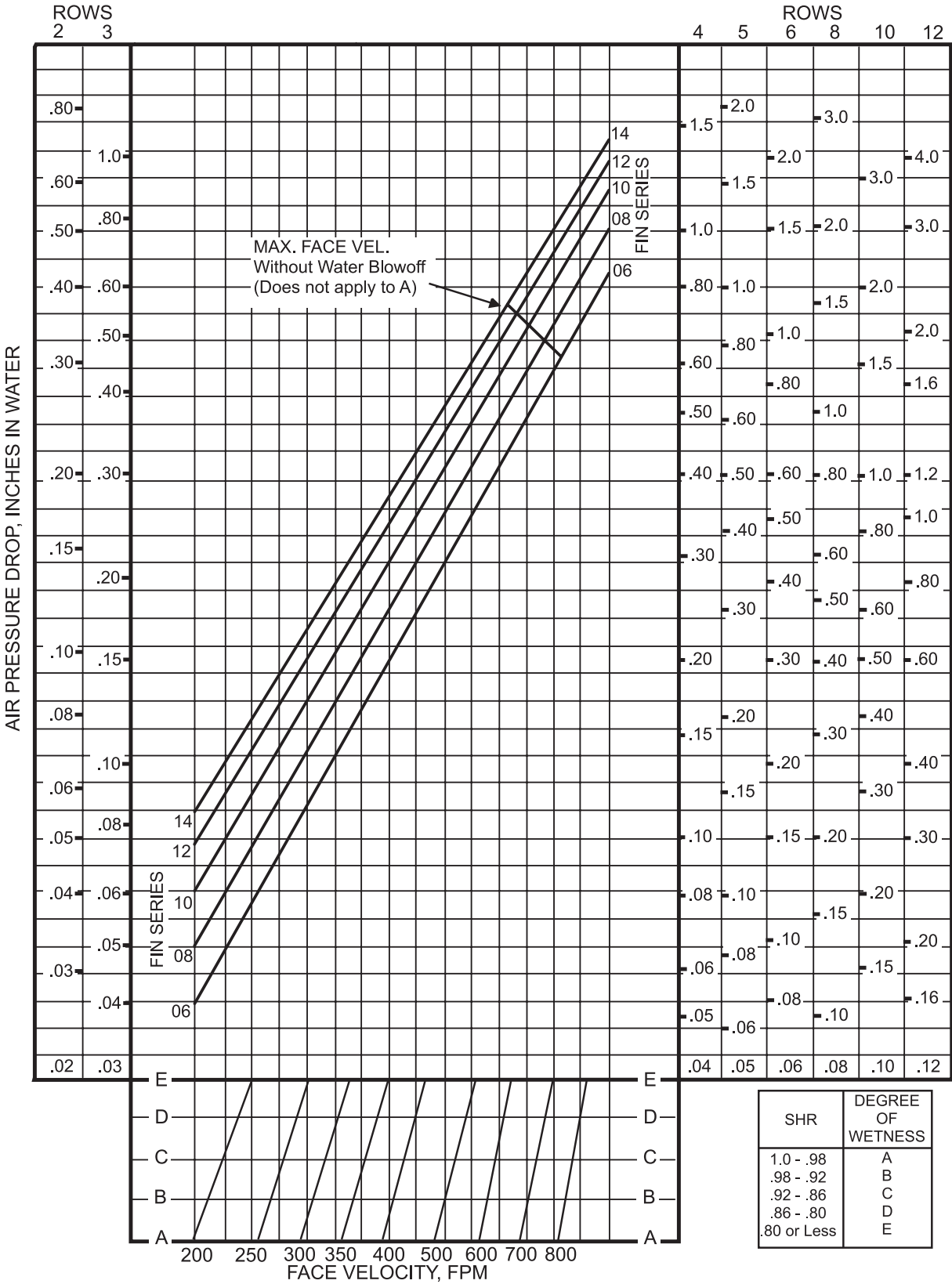

- Notes:
- The letters A,B,C,D or E following the face velocity indicate the degree of wetness at which the coil is operating.
  - Dry coils are shown by the letter A, wet coils by the letter E. Intermediate conditions are shown by the letters B, C, and D.
  - Air pressure drop for odd fin spacings can be found by interpolation.

Figure 24: Coil Air Pressure Drop—HI-F5 Fin Type

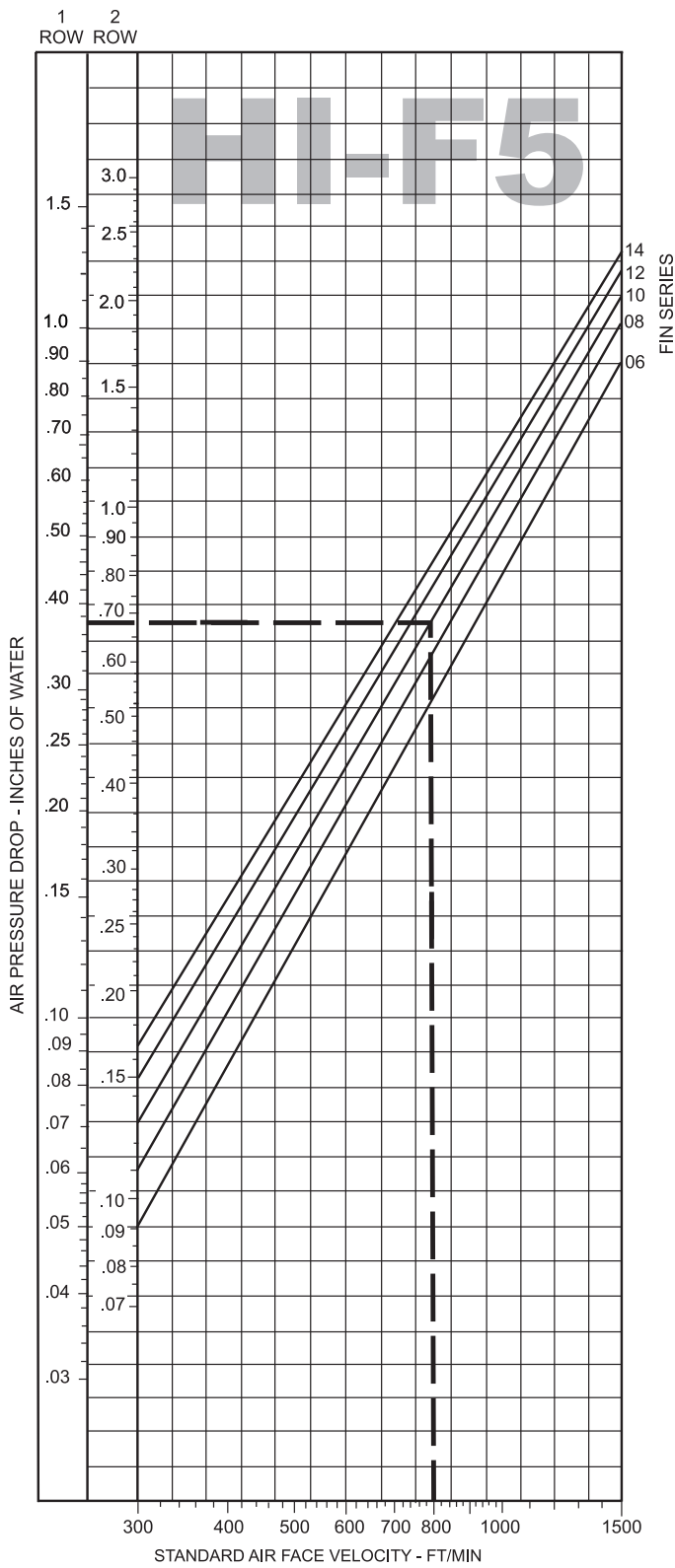
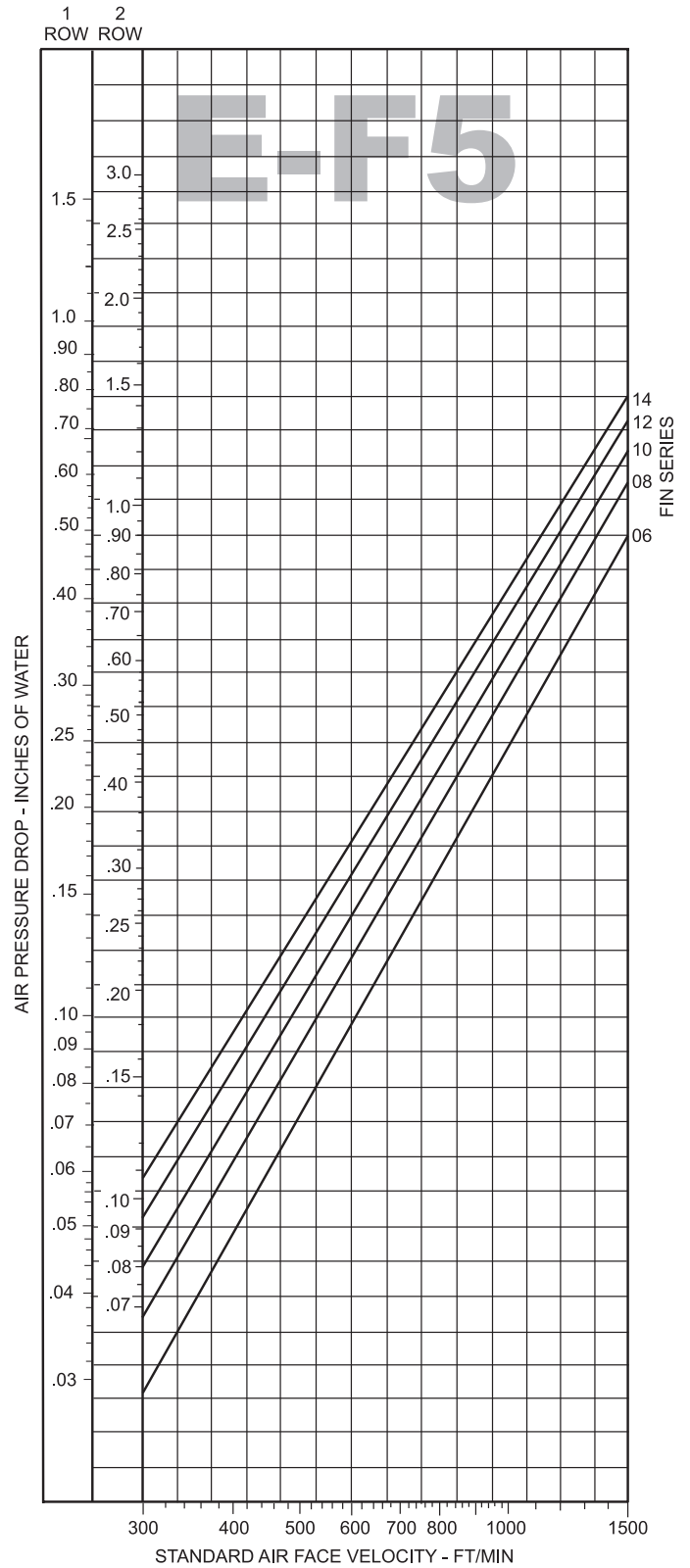
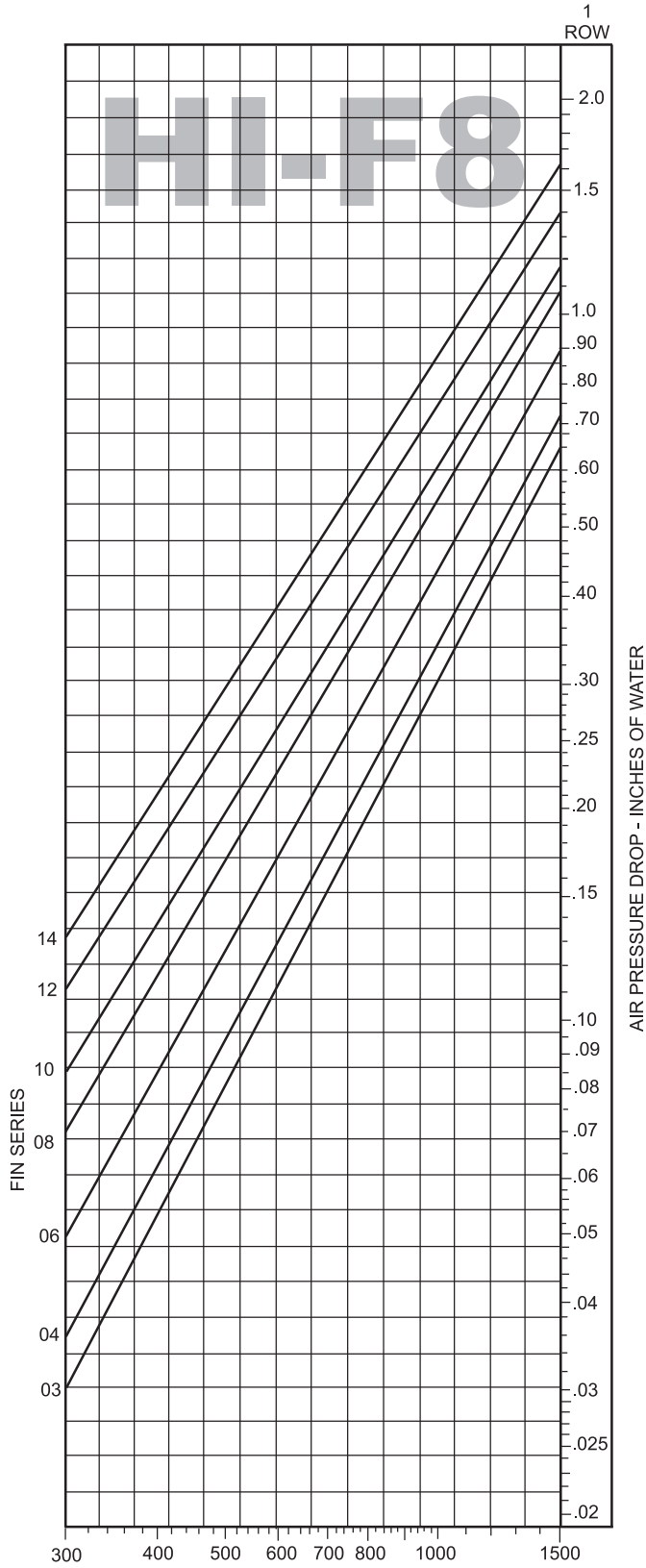

Figure 25: Coil Air Pressure Drop—E-F5 Fin Type



Note:  
Air pressure drop for odd fin spacings can be found by interpolation.

Figure 26: 1" Steam Coil Air Pressure Drop



Note:  
Air pressure drop for odd fin spacings can be found by interpolation.

# Component and Section Weights

**Table 10: Unit Coil Weights**

Unit size	003	004	006	008	010	012	014	017	021	025	030	035	040	050	065	080	085	090
Rows	lbs (kg)	lbs (kg)	lbs (kg)	lbs (kg)	lbs (kg)	lbs (kg)	lbs (kg)	lbs (kg)	lbs (kg)	lbs (kg)	lbs (kg)	lbs (kg)	lbs (kg)	lbs (kg)	lbs (kg)	lbs (kg)	lbs (kg)	lbs (kg)
1	18 (8)	23 (10)	29 (13)	36 (16)	43 (20)	53 (24)	60 (27)	67 (30)	78 (35)	108 (49)	123 (56)	143 (65)	156 (71)	212 (96)	267 (121)	434 (195)	449 (202)	466 (210)
2	26 (12)	33 (15)	43 (20)	54 (24)	66 (30)	83 (38)	92 (42)	107 (49)	125 (57)	166 (75)	189 (86)	222 (101)	258 (117)	345 (157)	446 (202)	663 (298)	678 (305)	711 (320)
3	37 (17)	47 (21)	63 (29)	81 (37)	99 (45)	122 (55)	139 (63)	161 (73)	207 (94)	247 (112)	291 (132)	339 (154)	403 (183)	559 (254)	731 (332)	1239* (558)	1297* (584)	1324* (596)
4	46 (21)	58 (26)	78 (36)	101 (46)	123 (56)	151 (69)	172 (78)	200 (91)	257 (117)	306 (139)	361 (164)	420 (191)	500 (227)	694 (315)	907 (412)	1711** (770)	1802** (811)	1892** (851)
5	55 (25)	70 (32)	94 (43)	120 (55)	147 (67)	181 (82)	206 (93)	239 (108)	307 (139)	366 (166)	432 (196)	502 (228)	598 (271)	829 (376)	1084 (492)	1959** (882)	2070** (932)	2180** (981)
6	64 (29)	81 (37)	109 (49)	140 (64)	171 (78)	210 (95)	239 (108)	278 (126)	357 (162)	425 (193)	502 (228)	584 (265)	695 (315)	964 (437)	1260 (572)	2252** (1013)	2383** (1072)	2512** (1130)
8	82 (37)	104 (47)	140 (63)	179 (81)	219 (99)	269 (122)	306 (139)	356 (161)	457 (207)	544 (247)	643 (292)	748 (339)	890 (404)	1234 (560)	1613 (732)	2828** (1273)	3009** (1354)	3182** (1432)
10	100 (45)	126 (57)	170 (77)	218 (99)	267 (121)	328 (149)	373 (169)	434 (197)	557 (253)	663 (301)	783 (355)	911 (413)	1084 (492)	1504 (682)	1966 (892)	NA	NA	NA
12	118 (53)	149 (68)	201 (91)	258 (117)	315 (143)	386 (175)	440 (200)	512 (232)	657 (298)	782 (355)	924 (419)	1075 (488)	1279 (580)	1774 (805)	2318 (1052)	NA	NA	NA

\* 3-row coils (unit sizes 080 to 090) based on staggered medium face area 5EJ with 6 FPI and standard fin, tube and casing materials.

\*\* 4 to 8-row coils (unit sizes 080 to 090) based on staggered medium face area with 12 FPI and standard fin, tube and casing materials

**Notes:**

- 1 and 2-row (unit sizes 003–065) based on large face area 5WQ and 5WH coils with 8 FPI and standard fin, tube and casing materials.
- 3-row and greater (unit sizes 003-065) based on large face area 5W\* or 5E\* coils with 8 FPI and standard fin, tube and casing materials.
- Staggered coils are not available in 10-row and 12-row coils.

**Table 11: Weights for Single Speed and Dual Speed Motors**

Motor rpm	Motor hp	1/4	1/3	1/3	3/8	1	1-1/2	2	3	5	7-1/2	10	15	20	25	30	40	50	60	75
900 rpm	NEMA frame	—	—	—	—	182T	184T	213T	215T	254T	256T	284T	286T	324T	326T	364T	365T	404T	405T	444T
	Motor weight lbs (kg)	—	—	—	—	56 (25)	64 (29)	94 (43)	111 (50)	150 (68)	207 (94)	300 (136)	300 (136)	385 (175)	415 (189)	580 (264)	580 (264)	750 (341)	800 (364)	1100 (500)
1200 rpm	NEMA frame	—	—	—	—	145T	182T	184T	213T	215T	256T	256T	284T	286T	324T	326T	365T	365T	404T	405T
	Motor weight lbs (kg)	—	—	—	—	44 (20)	66 (30)	85 (39)	114 (52)	145 (66)	224 (102)	248 (113)	330 (150)	377 (175)	450 (205)	487 (221)	703 (320)	720 (327)	1153 (524)	1200 (545)
1800 rpm	NEMA frame	48	48	56	56	143T	145T	145T	182T	184T	213T	215T	254T	256T	284T	286T	324T	326T	364T	365T
	Motor weight lbs (kg)	19 (9)	24 (11)	35 (16)	35 (16)	44 (20)	54 (24)	54 (24)	84 (38)	100 (45)	139 (63)	165 (75)	242 (110)	273 (124)	351 (159)	432 (196)	531 (241)	592 (269)	714 (324)	895 (406)
3600 rpm	NEMA frame	—	—	—	—	56T	143T	145T	145T	182T	184T	213T	215T	254T	256T	284TS	286TS	324TS	326TS	405TS
	Motor weight lbs (kg)	—	—	—	—	32 (15)	40 (18)	40 (18)	50 (23)	76 (35)	91 (41)	110 (50)	147 (67)	182 (83)	223 (101)	359 (163)	369 (168)	447 (203)	558 (254)	713 (324)
1800/900 rpm	NEMA frame	—	—	—	—	143	145	145	182	184	213	215	256	256	286	286	324	326	—	—
	Motor weight lbs (kg)	—	—	—	—	25 (11)	28 (13)	31 (14)	63 (29)	72 (33)	104 (47)	130 (59)	244 (111)	232 (105)	250 (114)	275 (125)	350 (159)	390 (177)	—	—
1800/1200 rpm	NEMA frame	—	—	—	—	145	182	182	184	215	256	256	284	286	286	—	—	—	—	
	Motor weight lbs (kg)	—	—	—	—	30 (14)	56 (25)	65 (30)	73 (33)	113 (51)	211 (96)	237 (108)	318 (145)	348 (158)	349 (159)	295 (134)	—	—	—	—

\* Data included reflects the largest NEMA frame and/or the heaviest motor weight per motor hp.



**Table 12: Base Rail Weights**

6" Base rail weights	Standard unit nominal size																	
	003	004	006	008	010	012	014	017	021	025	030	035	040	050	065	080	085	090
	lbs (kg)	lbs (kg)	lbs (kg)	lbs (kg)	lbs (kg)	lbs (kg)	lbs (kg)	lbs (kg)	lbs (kg)	lbs (kg)	lbs (kg)	lbs (kg)	lbs (kg)	lbs (kg)	lbs (kg)	lbs (kg)	lbs (kg)	lbs (kg)
End cross members (pair)	29 (13)	30 (14)	37 (17)	41 (19)	45 (20)	46 (21)	51 (23)	55 (25)	56 (25)	57 (26)	63 (29)	65 (29)	68 (31)	71 (32)				75 (34)
Additional cross member supports	10 (5)		14 (6)	15 (7)		17 (8)	19 (9)		21 (10)	22 (10)	26 (12)	27 (12)	30 (14)	32 (15)				35 (16)
10" Base rail weights	Standard unit nominal size																	
	003	004	006	008	010	012	014	017	021	025	030	035	040	050	065	080	085	090
	lbs (kg)	lbs (kg)	lbs (kg)	lbs (kg)	lbs (kg)	lbs (kg)	lbs (kg)	lbs (kg)	lbs (kg)	lbs (kg)	lbs (kg)	lbs (kg)	lbs (kg)	lbs (kg)	lbs (kg)	lbs (kg)	lbs (kg)	lbs (kg)
End cross members (pair)	39 (18)	40 (18)	50 (23)	55 (25)	60 (27)	62 (28)	69 (31)	74 (33)	75 (34)	78 (35)	86 (39)	89 (40)	92 (42)	95 (43)				107 (49)
Additional cross member supports	14 (6)	15 (7)	19 (9)	21 (10)	24 (11)	24 (11)	27 (12)	30 (14)	30 (14)	32 (15)	36 (16)	38 (17)	43 (20)	47 (21)				50 (23)

**Notes:**

- Weight factor for 6" high rail = .52 lb/in (.00929 kg/mm)
- Weight factor for 10" high rail = .74 lb/in (.0132 kg/mm)

The base rail weight is determined by adding together the weight of the rail supports that run the length and width of the unit. The lengthwise support depends on the overall unit length. The cross member weight is dependent on the number of cross channels needed to support the unit. Each shipping section has a cross member located on each end. When a unit ships in one piece, the rail will have 2 end channel supports. When the unit ships in numerous shipping sections, each shipping section will have two end pieces. Fan, coil, and attenuator sections each must have additional cross member support on the entering and leaving air side of the section. If the coil section is adjacent to a fan, only one cross member is provided between them. A heating only coil section must have an additional cross member support on the entering air side. Any shipping section over 8' long requires an additional cross member.

Base rails are required on sizes 025 and above.

**Example:**

Determine the weight of a 6" high base rail for a size 8 unit that is 108" long, consisting of a fan, access, coil, and angular filter in a single shipping section.

Weight factor for unit length for a 6" curb is .52 lb/in

$$108" \times 0.52 \text{ lb/in} = 56.0 \text{ lb} \dots\dots\dots 56 \text{ lb}$$

Weight of end cross members for each shipping section is 41 lb each pair.

$$1 \times 41.0 \text{ lb} = 41.0 \text{ lb} \dots\dots\dots 41 \text{ lb}$$

Weight of additional cross members to support fan and coil sections. In this example the fan and coil are separated by an access section; therefore four extra cross member pieces are required for the fan and coil.

$$4 \times 15.0 = 60.0 \text{ lb} \dots\dots\dots 60 \text{ lb}$$

$$\text{Total base rail weight} \dots\dots\dots \mathbf{157 \text{ lb}}$$

## Fan Data

**Table 13: Physical Data, Forward Curved and Airfoil Housed Fans, Unit Sizes 003 to 035**

Forward curved — Inches (millimeters)										
Diameter Class I	9 × 4 (229 × 102)	9 × 7 (229 × 178)	9 × 9 (229 × 229)	10.62 (270)	12.62 (321)	15 (381)	18 (457)	20 (508)	22.25 (565)	24.5 (622)
Maximum rpm	N/A	2189	2223	1934	1614	1328	1155	1050	944	858
Shaft and bearing diameter	N/A	1 (25)				1.188 (30)		1.938 (49)	2.1875 (56)	
Outlet area sq.ft. (sq.m.)	N/A	0.65 (0.060)	0.84 (0.078)	1.04 (0.097)	1.46 (0.136)	2.05 (0.190)	2.87 (0.267)	5.18 (0.481)	6.27 (0.58)	7.63 (0.71)
Diameter Class II	9 × 4 (229 × 102)	9 × 7 (229 × 178)	9 × 9 (229 × 229)	10.62 (270)	12.62 (321)	15 (381)	18 (457)	20 (508)	22.25 (565)	24.5 (622)
Maximum rpm	2244	2854	2896	2518	2091	1725	1450	1200	1030	910
Shaft and bearing diameter	1 (25)				1.188 (30)		1.938 (49)	2.188 (56)	2.4375 (62)	
Outlet area sq.ft. (sq.m.)	0.48 (0.045)	0.65 (0.060)	0.84 (0.078)	1.04 (0.097)	1.46 (0.136)	2.05 (0.190)	2.87 (0.267)	5.18 (0.481)	6.27 (0.58)	7.63 (0.71)
Airfoil — Inches (millimeters)										
Diameter Class I	13.22 (336)	14.56 (370)	16.19 (411)	19.69 (500)	21.56 (548)	24 (610)				
Maximum rpm	3000		2300	2000	1700	1500				
Shaft and bearing diameter	1.188 (30)	1.438 (37)		1.938 (49)		2.1875 (56)				
Outlet area sq.ft. (sq.m.)	2.11 (0.196)	2.85 (0.265)	3.52 (0.327)	4.68 (0.435)	5.82 (0.541)	7.01 (0.65)				
Diameter Class II	13.22 (336)	14.56 (370)	16.19 (411)	19.69 (500)	21.56 (548)	24 (610)				
Maximum rpm	4335	3918	3457	2858	2547	2255				
Shaft and bearing diameter	1.438 (37)	1.688 (43)		2.188 (56)	2.438 (62)					
Outlet area sq.ft. (sq.m.)	2.11 (0.196)	2.85 (0.265)	3.52 (0.327)	4.68 (0.435)	5.82 (0.541)	7.01 (0.65)				

**Table 14: Physical Data—Forward Curved and Airfoil Fans, Unit Sizes 040 to 090**

Forward curved — Inches (millimeters)								
<b>Diameter Class I</b>	<b>20 (508)</b>	<b>22.38 (568)</b>	<b>25 (635)</b>	<b>27.62 (702)</b>	<b>30.25 (768)</b>	<b>33 (838)</b>	<b>36 (914)</b>	<b>—</b>
Maximum rpm	1010	930	790	690	650	600	560	—
Shaft and bearing diameter	1.438 (37)		1.688 (43)			2.188 (56)		—
Outlet area sq.ft. (sq. m.)	4.2 (0.390)	5.1 (0.474)	6.71 (0.623)	8.07 (0.750)	9.3 (0.864)	12.05 (1.119)	12.8 (1.189)	—
<b>Diameter Class II</b>	<b>20 (508)</b>	<b>22.38 (568)</b>	<b>25 (635)</b>	<b>27.62 (702)</b>	<b>30.25 (768)</b>	<b>33 (838)</b>	<b>36 (914)</b>	<b>—</b>
Maximum rpm	1281	1178	1011	910	835	763	715	—
Shaft and bearing diameter	1.688 (43)	2.188 (56)	2.438 (62)		2.688 (68)			—
Outlet area sq.ft. (sq. m.)	4.2 (0.390)	5.1 (0.474)	6.71 (0.623)	8.07 (0.750)	9.3 (0.864)	12.05 (1.119)	12.8 (1.189)	—
Airfoil — Inches (millimeters)								
<b>Diameter Class I</b>	<b>20 (508)</b>	<b>22.25 (565)</b>	<b>24.5 (622)</b>	<b>27 (686)</b>	<b>30 (762)</b>	<b>33 (838)</b>	<b>36.5 (927)</b>	<b>40.25 (1022)</b>
Maximum rpm	2077	1875	1691	1479	1328	1209	1073	972
Shaft and bearing diameter	1.688 (43)	1.938 (49)	2.188 (56)		2.438 (62)			2.938 (75)
Outlet area sq.ft. (sq. m.)	4.14 (0.385)	5.12 (0.476)	6.21 (0.577)	7.54 (0.700)	9.31 (0.865)	11.27 (1.047)	13.79 (1.281)	16.77 (1.558)
<b>Diameter Class II</b>	<b>20 (508)</b>	<b>22.25 (565)</b>	<b>24.5 (622)</b>	<b>27 (686)</b>	<b>30 (762)</b>	<b>33 (838)</b>	<b>36.5 (927)</b>	<b>40.25 (1022)</b>
Maximum rpm	2703	2413	2199	1928	1730	1579	1401	1264
Shaft and bearing diameter	2.188 (56)		2.438 (62)		2.688 (68)	2.938 (75)		3.438 (87)
Outlet area sq.ft. (sq. m.)	4.14 (0.385)	5.12 (0.476)	6.21 (0.577)	7.54 (0.700)	9.31 (0.865)	11.27 (1.047)	13.79 (1.281)	16.77 (1.558)

**Table 15: Physical Data—Belt-Drive Plenum Fans**

Plenum — Inches (millimeters)																
Fan Size	13	15	16	18	20	22	24	27	30	33	36	40	44	49	54	60
<b>Diameter Class II</b>	<b>13.56 (344)</b>	<b>15.25 (387)</b>	<b>17.88 (454)</b>	<b>18.25 (464)</b>	<b>20.0 (508)</b>	<b>22.25 (565)</b>	<b>24.5 (622)</b>	<b>27.0 (686)</b>	<b>30.0 (762)</b>	<b>33.0 (838)</b>	<b>36.5 (927)</b>	<b>40.25 (1022)</b>	<b>44.5 (1130)</b>	<b>49.0 (1245)</b>	<b>54.25 (1378)</b>	<b>60.0 (1524)</b>
Maximum rpm	3909	3468	2820	2930	2674	2403	2183	1860	1783	1620	1465	1329	1202	1091	986	891
Shaft and bearing diameter	1.1875 (30.2)			1.4375 (36.5)		1.6875 (42.9)			1.9375 (49.2)	2.1875 (55.6)			2.4375 (61.9)		2.9375 (74.6)	
Outlet area sq.ft. (sq.m.)	N/A															

**Table 16: Physical Data—Direct-Drive Plenum Fans**

Plenum — Inches (millimeters)														
Diameter Class II	11	12	15	16	18	20	22	24	27	30	33	36	40	44
	(279)	(305)	(381)	(406)	(457)	(508)	(559)	(610)	(686)	(762)	(838)	(914)	(1016)	(1118)
Maximum rpm	4000	4000	3909	3650	3650	2674	2403	2183	1981	1783	1620	1465	1329	1202

**NOTE:** Includes fan array

**Table 17: Physical Data—Twin Fans**

Twin fans — Inches (millimeters)												
Diameter Class I	9.5 (241)		10.62 (270)		12.62 (321)		15 (381)	18.12 (460)		20 (508)		
Maximum rpm	2400/2575		2000/2400		1600/2000		1400/1700		1200/1400		1000/1200	
Shaft and bearing diameter	1.438 (36.5)				1.688 (42.9)		2.188 (55.6)		2.438 (61.9)		2.688 (68.3)	
Outlet area sq.ft. (sq.m.)	2.57 (0.23)		3.13 (0.29)		4.36 (0.40)		6.15 (0.56)		8.55 (0.77)		10.91 (1.00)	

# Coil Data

**Table 18: Unit Coil Dimensional Data**

Unit size	Standard chilled water, DX, or 3-row and 4-row heating coils Inches/square feet (millimeters/square meters)						Cleanable coils or 1-row and 2-row heating coils Inches/square feet (millimeters/square meters)					
	Coil dim.	Ext/Stagg Large	Large	Ext/Stagg Medium	Medium	Small	Coil dim.	Ext/Stagg Large	Large	Ext/Stagg Medium	Medium	Small
003	FH×FL	18×31 (457×787)	18×25 (457×635)	12×31 (305×787)	12×25 (305×635)	—	FH×FL	18×28 (457×711)	18×22 (457×559)	12×28 (305×711)	12×22 (305×559)	—
	Face area	3.9 (0.36)	3.1 (0.29)	2.6 (0.24)	2.1 (0.20)	—	Face area	3.5 (0.33)	2.8 (0.26)	2.3 (0.21)	1.8 (0.17)	—
004	FH×FL	21×33 (533×838)	21×27 (533×686)	15×33 (381×838)	15×27 (381×686)	12×27 (305×686)	FH×FL	21×30 (533×762)	21×24 (533×610)	15×30 (381×762)	15×24 (381×610)	12×24 (305×610)
	Face area	4.8 (0.45)	3.9 (0.36)	3.4 (0.32)	2.8 (0.26)	2.3 (0.21)	Face area	4.4 (0.41)	3.5 (0.33)	3.1 (0.29)	2.5 (0.23)	2.0 (0.19)
006	FH×FL	21×45 (533×1143)	21×39 (533×991)	15×45 (381×1143)	15×39 (381×991)	12×39 (305×991)	FH×FL	21×42 (533×1067)	21×36 (533×914)	15×42 (381×1067)	15×36 (381×914)	12×36 (305×914)
	Face area	6.6 (0.61)	5.7 (0.53)	4.7 (0.44)	4.1 (0.38)	3.3 (0.31)	Face area	6.1 (0.57)	5.3 (0.49)	4.4 (0.41)	3.8 (0.35)	3.0 (0.28)
008	FH×FL	24×51 (610×1295)	24×45 (610×1143)	18×51 (457×1295)	18×45 (457×1143)	15×45 (381×1143)	FH×FL	24×48 (610×1219)	24×42 (610×1067)	18×48 (457×1219)	18×42 (457×1067)	15×42 (381×1067)
	Face area	8.5 (0.79)	7.5 (0.70)	6.4 (0.59)	5.6 (0.52)	4.7 (0.44)	Face area	8.0 (0.74)	7.0 (0.65)	6.0 (0.56)	5.3 (0.49)	4.4 (0.41)
010	FH×FL	27×57 (686×1448)	27×51 (686×1295)	21×57 (533×1448)	21×51 (533×1295)	18×51 (457×1295)	FH×FL	27×54 (686×1372)	27×48 (686×1219)	21×54 (533×1372)	21×48 (533×1219)	18×48 (457×1219)
	Face area	10.7 (0.99)	9.6 (0.89)	8.3 (0.77)	7.4 (0.69)	6.4 (0.59)	Face area	10.1 (0.94)	9.0 (0.84)	7.9 (0.73)	7.0 (0.65)	6.0 (0.56)
012	FH×FL	33×59 (838×1499)	33×53 (838×1346)	24×59 (610×1499)	24×53 (610×1346)	21×53 (533×1346)	FH×FL	33×56 (838×1422)	33×50 (838×1270)	24×56 (610×1422)	24×50 (610×1270)	21×50 (533×1270)
	Face area	13.5 (1.25)	12.1 (1.12)	9.8 (0.91)	8.8 (0.82)	7.7 (0.72)	Face area	12.8 (1.19)	11.5 (1.07)	9.3 (0.86)	8.3 (0.77)	7.3 (0.68)
014	FH×FL	33×67 (838×1702)	33×61 (838×1549)	24×67 (610×1702)	24×61 (610×1549)	21×61 (533×1549)	FH×FL	33×64 (838×1626)	33×58 (838×1473)	24×64 (610×1626)	24×58 (610×1473)	21×58 (533×1473)
	Face area	15.4 (1.43)	14.0 (1.30)	11.2 (1.04)	10.2 (0.95)	8.9 (0.83)	Face area	14.7 (1.37)	13.3 (1.24)	10.7 (0.99)	9.7 (0.90)	8.5 (0.79)
017	FH×FL	36×73 (914×1854)	36×67 (914×1702)	27×73 (686×1854)	27×67 (686×1702)	24×67 (610×1702)	FH×FL	36×70 (914×1778)	36×64 (914×1626)	27×70 (686×1854)	27×64 (686×1626)	24×64 (610×1626)
	Face area	18.3 (1.70)	16.8 (1.56)	13.7 (1.27)	12.6 (1.17)	11.2 (1.04)	Face area	17.5 (1.63)	16.0 (1.49)	13.1 (1.22)	12.0 (1.11)	10.7 (0.99)
021	FH×FL	42×75 (1067×1905)	42×69 (1067×1753)	33×75 (838×1905)	33×69 (838×1753)	30×69 (762×1753)	FH×FL	42×72 (1067×1829)	42×66 (1067×1676)	33×72 (838×1829)	33×66 (838×1676)	30×66 (762×1676)
	Face area	21.9 (2.03)	20.1 (1.87)	17.2 (1.60)	15.8 (1.47)	14.4 (1.34)	Face area	21.0 (1.95)	19.3 (1.79)	16.5 (1.53)	15.1 (1.40)	13.8 (1.28)
025	FH×FL	48×79 (1219×2007)	48×73 (1219×1854)	—	36×73 (914×1854)	33×73 (838×1854)	FH×FL	—	—	42×70 (1067×1778)	36×70 (914×1778)	33×70 (838×1778)
	Face area	26.3 (2.44)	24.3 (2.26)	—	18.2 (1.89)	16.7 (1.55)	Face area	—	—	20.4 (1.89)	17.5 (1.63)	16.0 (1.49)
030	FH×FL	48×91 (1219×2312)	48×85 (1219×2159)	—	36×85 (914×2159)	33×85 (838×2159)	FH×FL	—	—	42×82 (1067×2083)	36×82 (914×2083)	33×82 (838×2083)
	Face area	30.3 (2.81)	28.3 (2.63)	—	21.2 (1.97)	19.5 (1.81)	Face area	—	—	23.9 (2.22)	20.5 (1.90)	18.8 (1.75)
035	FH×FL	54×95 (1372×2413)	54×89 (1372×2261)	—	42×89 (991×2261)	39×89 (914×2261)	FH×FL	—	—	—	42×86 (1067×2184)	39×86 (991×2184)
	Face area	35.6 (3.31)	33.4 (3.10)	—	24.1 (2.24)	22.3 (2.07)	Face area	—	—	—	23.3 (2.33)	21.5 (2.16)
040	FH×FL	54×109 (1372×2769)	54×103 (1372×2616)	—	42×103 (1067×2616)	39×103 (991×2616)	FH×FL	—	—	—	42×100 (1067×2540)	39×100 (991×2540)
	Face area	40.9 (3.80)	38.6 (3.59)	—	30.0 (2.79)	27.9 (2.59)	Face area	—	—	—	29.2 (2.81)	27.1 (2.49)
050	FH×FL	—	—	—	48×107 (1219×2718)	42×107 (1067×2718)	FH×FL	—	—	—	—	42×104 (1067×2642)
	Face area	—	—	—	35.7 (3.31)	31.2 (2.90)	Face area	—	—	—	—	30.3 (2.81)
065	FH×FL	2-39×107 (991×2718)	2-33×107 (838×2718)	2-27×107 (686×2718)	2-24×107 (610×2718)	—	FH×FL	2-39×104 (991×2642)	2-33×104 (838×2642)	2-27×104 (686×2642)	2-24×104 (610×2642)	—
	Face area	58.0 (5.39)	49.0 (4.55)	40.1 (3.72)	35.7 (3.32)	—	Face area	56.3 (5.23)	47.7 (4.43)	39.0 (3.62)	34.7 (3.22)	—

Table 20 continued: Unit Coil Dimensional Data

Standard chilled water, DX, or 3-row and 4-row heating coils Inches/square feet (millimeters/square meters)							Cleanable coils or 1-row and 2-row heating coils Inches/square feet (millimeters/square meters)					
Unit size	Coil dim.	Ext/Stagg Large	Large	Ext/Stagg Medium	Medium	Small	Coil dim.	Ext/Stagg Large	Large	Ext/Stagg Medium	Medium	Small
080	FH×FL	—	—	—	—	54×123 (1372×3124)	FH×FL	—	—	—	—	—
	Face area	—	—	—	—	46.1 (4.28)	Face area	—	—	—	—	—
	FH×FL	2-48×123 (1219×3124)	2-42×123 (1067×3124)	2-36×123 (915×3124)	2-30×123 (762×3124)	2-27×123 (686×3124)	FH×FL	—	2-42×120 (1067×3048)	2-36×120 (915×3048)	2-30×120 (762×3048)	2-27×120 (686×3048)
	Face area	82.0 (7.61)	71.8 (6.67)	61.5 (5.71)	51.2 (4.75)	46.1 (4.28)	Face area	—	70.0 (6.50)	60.0 (5.57)	50.0 (4.64)	45.0 (4.18)
085	FH×FL	—	—	—	—	—	FH×FL	—	—	—	—	—
	Face area	—	—	—	—	—	Face area	—	—	—	—	—
	FH×FL	2-51×123 (1296×3124)	2-45×123 (1143×3124)	2-39×123 (991×3124)	2-33×123 (838×3124)	2-30×123 (762×3124)	FH×FL	—	—	2-39×120 (991×3048)	2-33×120 (838×3048)	2-30×120 (762×3048)
	Face area	87.1 (8.09)	76.9 (7.14)	66.6 (6.18)	56.4 (5.24)	51.2 (4.75)	Face area	—	—	65.0 (6.04)	55.0 (5.11)	50.0 (4.64)
090	FH×FL	—	—	—	—	—	FH×FL	—	—	—	—	—
	Face area	—	—	—	—	—	Face area	—	—	—	—	—
	FH×FL	2-54×123 (1372×3124)	2-48×123 (1219×3124)	2-42×123 ( ) 1067×3124	2-36×123 (915×3124)	2-33×123 (838×3124)	FH×FL	—	—	2-42×120 (1067×3048)	2-36×120 (915×3048)	2-33×120 (838×3048)
	Face area	92.2 (8.56)	82.0 (7.61)	71.8 (6.67)	61.5 (5.71)	56.4 (5.24)	Face area	—	—	70.0 (6.50)	60.0 (5.57)	55.0 (5.11)

**Coil section depth limitation by number of rows in coil for single banks of coils (excludes staggered coils)**  
**Section depth . . . . . Maximum number of rows**  
 12" (305) . . . . . 2-row water or steam  
 14" (356) . . . . . 4-row water (except 5WM and 5WD)  
 16" (406) . . . . . 4-row 5WM & 5WD water

**Cooling only section (no moisture eliminator)**  
**Section depth . . . . . Maximum number of rows**  
 18" (457) . . . . . 4-row DX or water (except 5WM and 5WD)  
 24" (610) . . . . . 8-row DX or water  
 30" (762) . . . . . 10-row DX or 12 water

**Combination cooling and 1-row or 2-row reheat (no moisture eliminator)**  
**Section depth . . . . . Maximum number of rows**  
 24" (610) . . . . . 6-row water or DX  
 30" (762) . . . . . 10-row water or DX  
 36" (914) . . . . . 12-row water

**Notes:** Spacing between coil casings is a minimum of 4". If more access between coils is required, increase section depth. Cooling coil sections are available in section depths of 18" (457mm), 24" (610mm), 30" (762mm), 36" (914mm), 42" (1067mm), 48" (1219mm), 154" (1372mm). If a moisture eliminator is required, use the next larger section size.

## Multi-zone Coils

The face area of the multi-zone cold deck coil is the same as other cooling coils shown in [Table 20 on page 49](#). Multi-zone hot deck coils have a face area that is different from other heating coils. The face area for the multi-zone hot deck is generally smaller.

The minimum section depth for multi-zone sections is shown starting on [page 71](#). Additional access is available downstream from the cooling coil. Refer to Daikin SelectTools Software for more detailed information.

**Table 19: Multi-zone Coil Dimensional Data**

Multi-zone hot deck coils			
Inches/square feet (millimeters/square meters)			
Unit size	Coil Dimensions	1-row & 2-row	3-row & 4-row
006	FH × FL	12 × 36 (305 × 914)	12 × 39 (305 × 991)
	Face area	3.0 (0.28)	3.3 (0.31)
008	FH × FL	15 × 42 (381 × 1067)	15 × 45 (381 × 1143)
	Face area	4.4 (0.41)	4.7 (0.44)
010	FH × FL	15 × 48 (381 × 1219)	15 × 51 (381 × 1295)
	Face area	5.0 (0.46)	5.3 (0.49)
012	FH × FL	18 × 50 (457 × 1270)	18 × 53 (457 × 1346)
	Face area	6.3 (0.59)	6.6 (0.61)
014	FH × FL	18 × 58 (457 × 1473)	18 × 61 (457 × 1549)
	Face area	7.3 (0.68)	7.6 (0.71)
017	FH × FL	21 × 64 (533 × 1626)	21 × 67 (533 × 1702)
	Face area	9.3 (0.86)	9.8 (0.91)
021	FH × FL	24 × 66 (610 × 1676)	24 × 69 (610 × 1753)
	Face area	11.0 (1.02)	11.5 (1.07)
025	FH × FL	27 × 70 (686 × 1778)	27 × 73 (686 × 1854)
	Face area	13.1 (1.22)	13.7 (1.27)
030	FH × FL	27 × 82 (686 × 2083)	27 × 85 (686 × 2159)
	Face area	15.4 (1.43)	15.9 (1.48)
035	FH × FL	30 × 86 (762 × 2184)	30 × 89 (762 × 2261)
	Face area	17.9 (1.66)	18.5 (1.72)
040	FH × FL	30 × 100 (762 × 2540)	30 × 103 (762 × 2616)
	Face area	20.8 (1.93)	21.5 (2.0)
050	FH × FL	36 × 104 (914 × 2642)	36 × 107 (914 × 2718)
	Face area	26.0 (2.42)	26.8 (2.49)
065	FH × FL	42 × 120 (1067 × 3048)	42 × 123 (1067 × 3124)
	Face area	35.0 (3.25)	35.9 (3.34)
080	FH × FL	N/A	N/A
	Face area	N/A	N/A
085	FH × FL	N/A	N/A
	Face area	N/A	N/A
090	FH × FL	N/A	N/A
	Face area	N/A	N/A



## Side Load Filter Data

**Table 20: Size and Quantity of Filters Used Per Unit Size**

Unit size	Filter size (inches)	Number of filters used per filter section						
		2" throwaway(TA)	2" angular	4" angular	12" cartridge	4" cartridge	12" mini pleat	Bag
003	12 x 24		2					
	20 x 20							
	20 x 24		2					
	24 x 12			N/A				
	24 x 20	1			1	1	1	1
004	24 x 24							
	12 x 24	1	2		1	1	1	1
	20 x 20							
	20 x 24							
	24 x 12			N/A				
006	24 x 20							
	24 x 24	1	2		1	1	1	1
	12 x 24							
	20 x 20							
	20 x 24							
008	24 x 12			N/A				
	24 x 20							
	24 x 24	2	4		2	2	2	2
	12 x 24	1	2	2	1	1	1	1
	20 x 20							
010	20 x 24	1	2	2	2	2	2	2
	24 x 12							
	24 x 20							
	24 x 24	1	2	2				
	12 x 24				1			
012	20 x 20							
	20 x 24	3	6	6		3	3	3
	24 x 12							
	24 x 20							
	24 x 24				2			
014	12 x 24	1			1	1	1	1
	20 x 20							
	20 x 24		4	4				
	24 x 12	2			2	2	2	2
	24 x 20							
017	24 x 24	2	2	2	2	2	2	2
	12 x 24							
	20 x 20							
	20 x 24				1	1	1	1
	24 x 12	3			2	2	2	2
021	24 x 20							
	24 x 24	3	6	6	2	2	2	2
	12 x 24		3	3				
	20 x 20							
	20 x 24		6	6				
025	24 x 12	6			6	6	6	6
	24 x 20							
	24 x 24		3	3				
	12 x 24	4			4	4		4
	20 x 24	4	12	12	4	4		4
025	24 x 12						3	
	24 x 20						3	
	12 x 24				2	2	2	2
	20 x 20							
	20 x 24	6	9	9				
025	24 x 12							
	24 x 20							
	24 x 24	2	3	3	6	6	6	6

**Table 22 continued: Size and Quantity of Filters Used Per Unit Size**

Unit size	Filter size (inches)	Number of filters used per filter section						
		2" throwaway(TA)	2" angular	4" angular	12" cartridge	4" cartridge	12" mini pleat	Bag
030	12 x 24							
	20 x 20							
	20 x 24							
	24 x 12	4			4	4	4	4
	24 x 20	8			8	8	8	8
035	24 x 24		12	12				
	12 x 24							
	20 x 20	15			15	15		15
	20 x 24		20	20				
	24 x 12						12	
040	24 x 20						12	
	24 x 24							
	12 x 24		4	4			2	
	20 x 20	6			6	6		6
	20 x 24	16	16					
050	24 x 12						4	
	24 x 20	9			9	9		9
	24 x 24		4	4			8	
	12 x 24							
	20 x 20							
065	20 x 24	3	24	24	3	3	3	3
	24 x 12							
	24 x 20							
	24 x 24	12			12	12	12	12
	12 x 24				3		3	
080	20 x 20		9			9		9
	20 x 24	3	10	10		3		3
	24 x 12				5		5	
	24 x 20	9				9		9
	24 x 24	3	20	20	15	3	15	3
085	12 x 24				3		3	
	20 x 20		3			3		3
	20 x 24	9	10	10		9		9
	24 x 12							
	24 x 20	3			5	3	5	3
090	24 x 24	9	20	20	15	9	15	9
	12 x 24	4		4	4	4	4	4
	20 x 20							
	20 x 24	12	12	12				
	24 x 12							
090	24 x 20	4	24	24	20	20	20	20
	12 x 24						3	
	20 x 20	12			15	12		12
	20 x 24	3	12	12		3		3
	24 x 12						5	
090	24 x 20	12			15	12	5	12
	24 x 24	3	24	24		3	15	3

Note: Number of filters used per flat panel, 2" angular, and 4" angular filtersection is based on pleated (30%).

### Top Horizontal Housed Fan Discharge

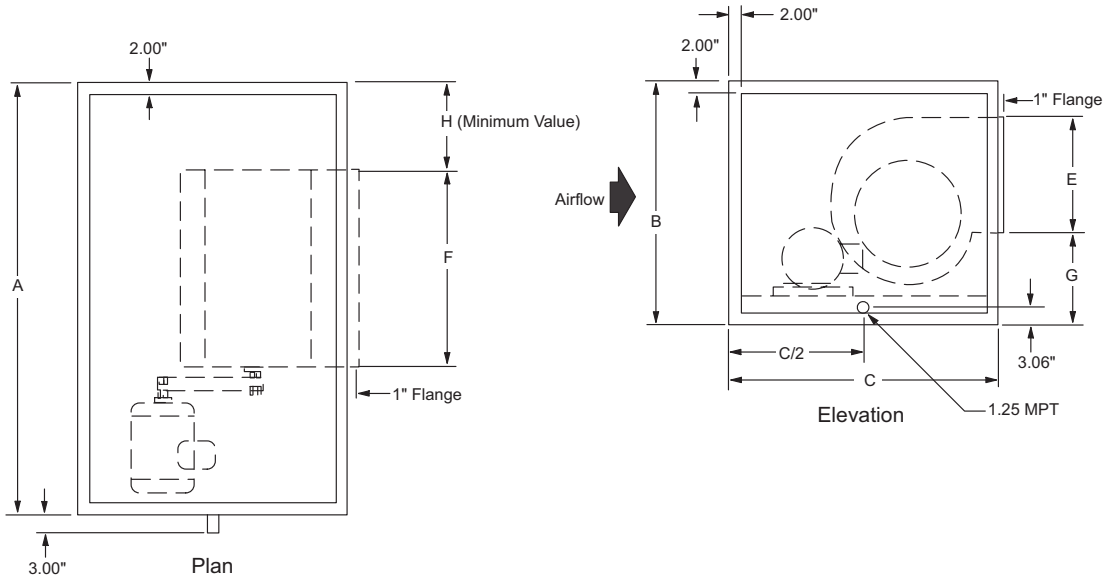

Note: The H dimension shown is the minimum value. This dimension varies with the motor size used.

Table 21: Fan Opening Dimensions—Models 003 to 090

Models 003 to 035			
	Fan dia. (Inches)	E, In. (mm)	F, In. (mm)
FC	9 × 4	11.05 (281)	7.61 (193)
	9 × 7	11.05 (281)	9.99 (254)
	9 × 9	11.05 (281)	12.61 (320)
	10.62	12.18 (309)	13.92 (354)
	12.62	14.24 (362)	16.42 (417)
	15	16.68 (424)	19.42 (493)
	18	19.68 (500)	22.68 (576)
	20	27.27 (693)	28.98 (736)
	22.25	29.51 (750)	32.23 (819)
	24.5	32.51 (826)	35.45 (900)
	Fan dia. (Inches)	E, In. (mm)	F, In. (mm)
Airfoil	13.22	16.68 (424)	19.94 (506)
	14.56	20.18 (513)	22.00 (559)
	16.19	22.37 (568)	24.31 (617)
	19.69	24.13 (613)	29.70 (754)
	21.56	27.27 (693)	32.45 (824)
	24	29.51 (750)	35.95 (913)
Models 040 to 090			
	Fan dia. (Inches)	E, In. (mm)	F, In. (mm)
FC	20	25.55 (649)	25.55 (649)
	22.38	28.05 (712)	28.05 (712)
	25	32.05 (814)	32.05 (814)
	27.62	35.05 (890)	35.05 (890)
	30.25	37.55 (954)	37.55 (954)
	33	43.74 (1111)	40.55 (1030)
	36	43.74 (1111)	43.55 (1106)
	Fan dia. (Inches)	E, In. (mm)	F, In. (mm)
Airfoil	20	22.05 (560)	29.49 (749)
	22.25	24.43 (621)	32.18 (817)
	24.5	26.74 (679)	35.68 (906)
	27	29.43 (748)	39.11 (993)
	30	32.61 (828)	43.24 (1098)
	33	35.74 (908)	47.99 (1219)
	36.5	39.49 (1003)	52.55 (1335)
40.25	43.36 (1101)	58.30 (1481)	

**Table 22: Top Horizontal Housed Fan Dimensions**

Unit size	Fan diameter (Inches)	A** In. (mm)	B** In. (mm)	C In. (mm)	G In. (mm)	H (minimum) In. (mm)
003	9 × 4, 9 × 7 FC*	38.00 (965)	26.00 (660)	32.00 (813)	9.93 (252)	8.18 (208)
004	9 × 9 FC*	40.00 (1016)	30.00 (762)	32.00 (813)	9.93 (252)	8.18 (208)
006	9 × 7, 9 × 9 FC*	52.00 (1321)	30.00 (762)	32.00 (813)	9.93 (252)	8.18 (208)
006	10.62 FC*	52.00 (1321)	30.00 (762)	36.00 (914)	12.74 (324)	9.43 (240)
008	12.62 FC	58.00 (1473)	34.00 (864)	40.00 (1016)	14.61 (371)	10.83 (275)
008	13.22AF	58.00 (1473)	34.00 (864)	40.00 (1016)	13.88 (353)	11.25 (286)
010	15 FC	64.00 (1626)	36.00 (914)	42.00 (1067)	15.55 (395)	12.50 (318)
010	13.22AF	64.00 (1626)	36.00 (914)	40.00 (1016)	13.88 (353)	11.25 (286)
012	18 FC	66.00 (1676)	42.00 (1067)	46.00 (1168)	16.80 (427)	14.62 (371)
012	16.19AF	66.00 (1676)	42.00 (1067)	46.00 (1168)	14.28 (363)	13.33 (339)
014	18 FC	74.00 (1880)	42.00 (1067)	46.00 (1168)	16.80 (427)	14.62 (371)
014	16.19AF	74.00 (1880)	42.00 (1067)	46.00 (1168)	14.28 (363)	13.33 (339)
017	18 FC	80.00 (2032)	46.00 (1168)	46.00 (1168)	16.80 (427)	14.62 (371)
017	19.69AF	80.00 (2032)	46.00 (1168)	50.00 (1270)	16.09 (409)	15.78 (401)
021	20 FC	82.00 (2083)	52.00 (1321)	52.00 (1321)	15.82 (402)	16.00 (406)
021	21.56AF	82.00 (2083)	52.00 (1321)	52.00 (1321)	16.06 (408)	17.09 (434)
025	24.50 FC*	86.00 (2184)	60.00 (1524)	60.00 (1524)	18.63 (473)	19.15 (486)
025	24AF	86.00 (2184)	60.00 (1524)	58.00 (1473)	17.55 (446)	18.80 (478)
030	24.50 FC	98.00 (2489)	60.00 (1524)	60.00 (1524)	18.63 (473)	19.15 (486)
030	24AF	98.00 (2489)	60.00 (1524)	58.00 (1473)	17.55 (446)	18.80 (478)
035	24.50 FC	102.00 (2591)	66.00 (1676)	60.00 (1524)	18.63 (473)	19.15 (486)
035	24AF	102.00 (2591)	66.00 (1676)	58.00 (1473)	17.55 (446)	18.80 (478)
040	27.62 FC	116.00 (2946)	68.00 (1727)	74.00 (1880)	26.28 (668)	40.47 (1028)
040	27AF	116.00 (2946)	68.00 (1727)	70.00 (1778)	33.10 (841)	38.45 (977)
050	36 FC	120.00 (3048)	80.00 (2032)	82.00 (2083)	25.90 (658)	36.22 (971)
050	33AF	120.00 (3048)	80.00 (2032)	80.00 (2032)	38.15 (969)	30.00 (863)
065	40.25AF	136.00 (3454)	92.00 (2337)	92.00 (2337)	43.65 (1109)	34.85 (987)
080	40.25AF	136.00 (3454)	98.00 (2489)	92.00 (2337)	43.65 (1109)	34.85 (987)
085	40.25AF	136.00 (3454)	104.00 (2641)	92.00 (2337)	43.65 (1109)	34.85 (987)
090	40.25AF	136.00 (3454)	110.00 (2794)	92.00 (2337)	43.65 (1109)	34.85 (987)

\* Not available with vanes.

\*\* These are the dimensions of the unit only. A standard base rail adds 8" (203 mm) to the width, and between 4" to 12" (102 mm to 305 mm) to the unit height. A 6" (152 mm) base rail is mandatory on unit sizes 025-065. An 8" (203 mm) base rail is mandatory on unit sizes 080 and larger.

### Bottom Horizontal Housed Fan Discharge

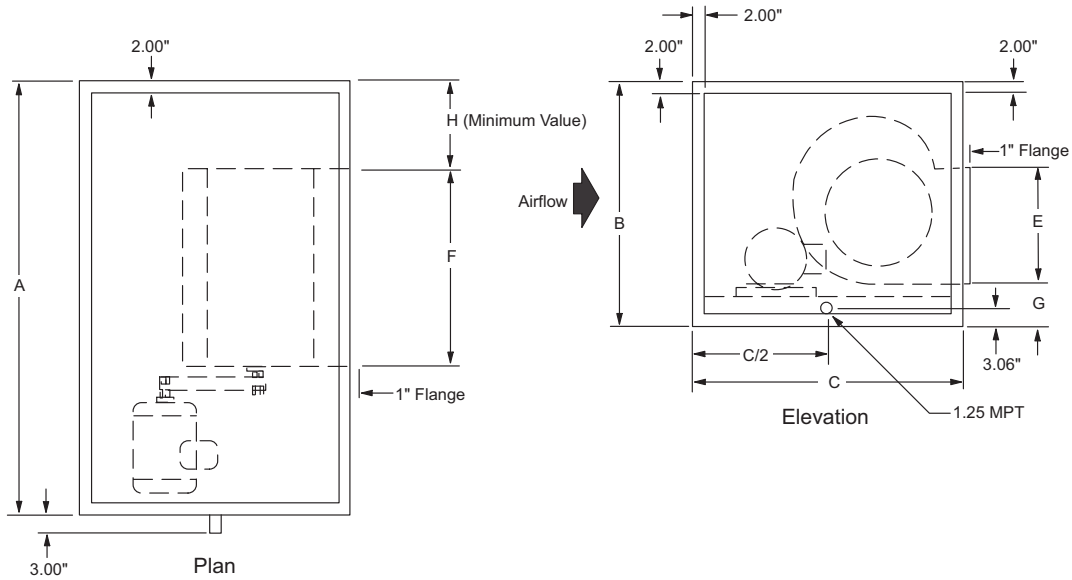

Note: The H dimension shown is the minimum value. This dimension varies with the motor size used.

Table 23: Fan Opening Dimensions—Models 003 to 090

Models 003 to 035			
	Fan dia. (Inches)	E, In. (mm)	F, In. (mm)
FC	9 × 4	11.05 281	7.61 193
	9 × 7	11.05 281	9.99 254
	9 × 9	11.05 281	12.61 320
	10.62	12.18 309	13.92 354
	12.62	14.24 362	16.42 417
	15	16.68 424	19.42 493
	18	19.68 500	22.68 576
	20	27.27 693	28.98 736
Airfoil	22.25	29.51 750	32.23 819
	24.5	32.51 826	35.45 900
	Fan dia. (Inches) E, In. (mm) F, In. (mm)		
	13.22	16.68 424	19.94 506
	14.56	20.18 513	22.00 559
16.19	22.37 568	24.31 617	
19.69	24.13 613	29.70 754	
21.56	27.27 693	32.45 824	
24	29.51 750	35.95 913	
Models 040 to 090			
	Fan dia. (Inches)	E, In. (mm)	F, In. (mm)
FC	20	25.55 649	25.55 649
	22.38	28.05 712	28.05 712
	25	32.05 814	32.05 814
	27.62	35.05 890	35.05 890
	30.25	37.55 954	37.55 954
	33	43.74 1111	40.55 1030
Airfoil	36	43.74 1111	43.55 1106
	Fan dia. (Inches) E, In. (mm) F, In. (mm)		
	20	22.05 560	29.49 749
	22.25	24.43 621	32.18 817
	24.5	26.74 679	35.68 906
	27	29.43 748	39.11 993
	30	32.61 828	43.24 1098
	33	35.74 908	47.99 1219
36.5	39.49 1003	52.55 1335	
40.25	43.36 1101	58.30 1481	

**Table 24: Bottom Horizontal Housed Fan Dimensions**

Unit size	Fan diameter (Inches)	A** In. (mm)	B** In. (mm)	C In. (mm)	G In. (mm)	H (minimum) In. (mm)
003	9 × 4, 9 × 7 FC*	38.00 (965)	26.00 (660)	32.00 (813)	6.43 (163)	8.18 (208)
004	9 × 9 FC*	40.00 (1016)	30.00 (762)	32.00 (813)	6.43 (163)	8.18 (208)
006	9 × 7, 9 × 9 FC*	52.00 (1321)	30.00 (762)	32.00 (813)	6.43 (163)	8.18 (208)
006	10.62 FC*	52.00 (1321)	30.00 (762)	36.00 (914)	8.50 (216)	9.43 (240)
008	12.62 FC	58.00 (1473)	34.00 (864)	40.00 (1016)	8.50 (216)	10.83 (275)
008	13.22 AF	58.00 (1473)	34.00 (864)	40.00 (1016)	8.50 (216)	11.25 (286)
010	15 FC	64.00 (1626)	36.00 (914)	42.00 (1067)	8.50 (216)	12.50 (318)
010	13.22 AF	64.00 (1626)	36.00 (914)	40.00 (1016)	8.50 (216)	11.25 (286)
012	18 FC	66.00 (1676)	42.00 (1067)	46.00 (1168)	8.50 (216)	14.62 (371)
012	16.19 AF	66.00 (1676)	42.00 (1067)	46.00 (1168)	8.50 (216)	13.33 (339)
014	18 FC	74.00 (1880)	42.00 (1067)	46.00 (1168)	8.50 (216)	14.62 (371)
014	16.19 AF	74.00 (1880)	42.00 (1118)	46.00 (1168)	8.50 (216)	13.33 (339)
017	18 FC	80.00 (2032)	46.00 (1168)	46.00 (1168)	8.50 (216)	14.62 (371)
017	19.69 AF	80.00 (2032)	46.00 (1168)	50.00 (1270)	8.50 (216)	15.78 (401)
021	20 FC	82.00 (2083)	52.00 (1321)	52.00 (1321)	8.50 (216)	16.00 (406)
021	21.56 AF	82.00 (2083)	52.00 (1321)	52.00 (1321)	8.50 (216)	17.09 (434)
025	24.50 FC*	86.00 (2184)	60.00 (1524)	60.00 (1524)	8.50 (216)	19.15 (486)
025	24 AF	86.00 (2184)	60.00 (1524)	58.00 (1473)	8.50 (216)	18.80 (478)
030	24.50 FC	98.00 (2489)	60.00 (1524)	60.00 (1524)	8.50 (216)	19.15 (486)
030	24 AF	98.00 (2489)	60.00 (1524)	58.00 (1473)	8.50 (216)	18.80 (478)
035	24.50 FC	102.00 (2591)	66.00 (1676)	60.00 (1524)	8.50 (216)	19.15 (486)
035	24 AF	102.00 (2591)	66.00 (1676)	58.00 (1473)	8.50 (216)	18.80 (478)
040	27.62 FC	116.00 (2946)	90.00 (2286)	74.00 (1880)	13.03 (331)	40.47 (1028)
040	27 AF	116.00 (2946)	90.00 (2286)	70.00 (1778)	13.47 (342)	38.45 (977)
050	36 FC	120.00 (3048)	80.00 (2032)	82.00 (2083)	13.09 (333)	36.22 (971)
050	33 AF	120.00 (3048)	80.00 (2032)	80.00 (2032)	14.21 (361)	30.00 (863)
065	40.25 AF	136.00 (3454)	92.00 (2337)	92.00 (2337)	14.09 (358)	34.85 (987)
080	40.25 AF	136.00 (3454)	98.00 (2489)	92.00 (2337)	14.09 (358)	34.85 (987)
085	40.25 AF	136.00 (3454)	104.00 (2641)	92.00 (2337)	14.09 (358)	34.85 (987)
090	40.25 AF	136.00 (3454)	110.00 (2794)	92.00 (2337)	14.09 (358)	34.85 (987)

\* Not available with vanes.

\*\* These are the dimensions of the unit only. A standard base rail adds 8" (203 mm) to the width, and between 4" to 12" (102 mm to 305 mm) to the unit height. A 6" (152 mm) base rail is mandatory on unit sizes 025-065. An 8" (203 mm) base rail is mandatory on unit sizes 080 and larger.



### Upblast Houed Fan Discharge

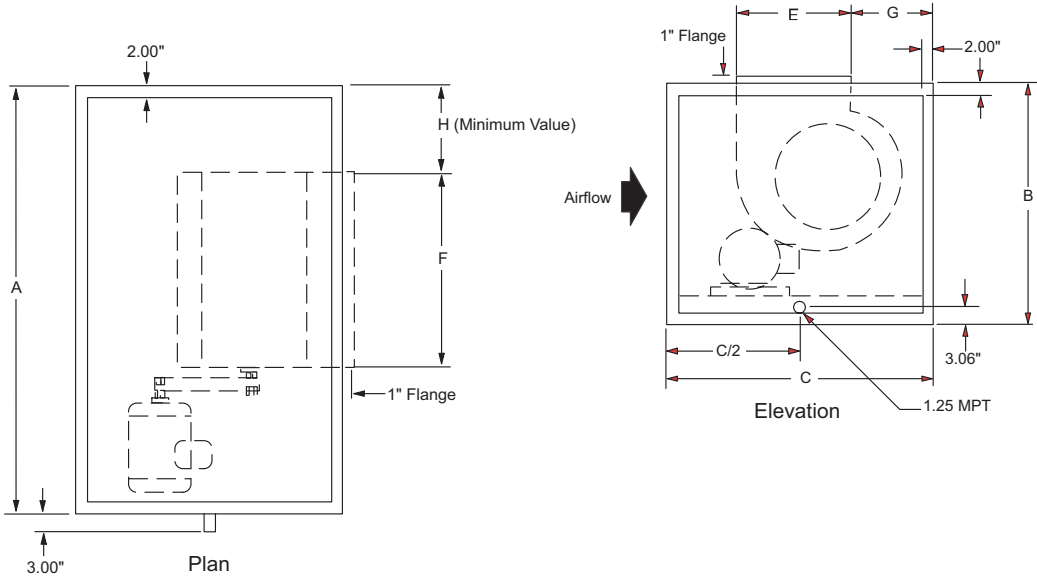

Note: The H dimension shown is the minimum value. This dimension varies with the motor size used.

Table 25: Fan Opening Dimensions—Models 003 to 090

Models 003 to 035				
	Fan dia. (Inches)	E, In. (mm)	F, In. (mm)	
FC	9 × 4	11.05 (281)	7.61 (193)	
	9 × 7	11.05 (281)	9.99 (254)	
	9 × 9	11.05 (281)	12.61 (320)	
	10.62	12.18 (309)	13.92 (354)	
	12.62	14.24 (362)	16.42 (417)	
	15	16.68 (424)	19.42 (493)	
	18	19.68 (500)	22.68 (576)	
	20	27.27 (693)	28.98 (736)	
Airfoil	22.25	29.51 (750)	32.23 (819)	
	24.5	32.51 (826)	35.45 (900)	
	13.22	16.68 (424)	19.94 (506)	
	14.56	20.18 (513)	22.00 (559)	
	16.19	22.37 (568)	24.31 (617)	
Airfoil	19.69	24.13 (613)	29.70 (754)	
	21.56	27.27 (693)	32.45 (824)	
	24	29.51 (750)	35.95 (913)	
	Models 040 to 090			
		Fan dia. (Inches)	E, In. (mm)	F, In. (mm)
FC	20	25.55 (649)	25.55 (649)	
	22.38	28.05 (712)	28.05 (712)	
	25	32.05 (814)	32.05 (814)	
	27.62	35.05 (890)	35.05 (890)	
	30.25	37.55 (954)	37.55 (954)	
	33	43.74 (1111)	40.55 (1030)	
Airfoil	36	43.74 (1111)	43.55 (1106)	
	20	22.05 (560)	29.49 (749)	
	22.25	24.43 (621)	32.18 (817)	
	24.5	26.74 (679)	35.68 (906)	
	27	29.43 (748)	39.11 (993)	
	30	32.61 (828)	43.24 (1098)	
	33	35.74 (908)	47.99 (1219)	
	36.5	39.49 (1003)	52.55 (1335)	
40.25	43.36 (1101)	58.30 (1481)		

**Table 26: Upblast Housed Fan Dimensions**

Unit size	Fan diameter (Inches)	A** In. (mm)	B** In. (mm)	C In. (mm)	G In. (mm)	H (minimum) In. (mm)
003	9 × 4, 9 × 7 FC*	38.00 965	26.00 660	32.00 813	8.49 216	8.18 208
004	9 × 7, 9 × 9 FC*	40.00 1016	30.00 762	32.00 813	8.49 216	8.18 208
006	10.62 FC*	52.00 1321	30.00 762	36.00 914	12.03 306	9.43 240
008	15 FC	58.00 1473	30.00 762	42.00 1067	13.76 350	12.50 318
008	13.22 AF	58.00 1473	34.00 864	40.00 1016	12.30 312	11.25 286
010	18 FC	64.00 1626	34.00 864	46.00 1168	15.14 385	14.62 371
010	16.19 AF	64.00 1626	36.00 914	46.00 1168	12.56 319	13.33 339
012	18 FC	66.00 1676	36.00 914	46.00 1168	15.17 385	14.62 371
012	16.19 AF	66.00 1676	42.00 1067	46.00 1168	12.56 319	13.33 339
014	20 FC	74.00 1880	42.00 1067	52.00 1321	14.07 357	16.00 406
014	19.69 AF	74.00 1880	42.00 1067	50.00 1270	14.54 369	15.78 401
017	20 FC	80.00 2032	42.00 1118	52.00 1321	14.07 357	16.00 406
017	21.56 AF	80.00 2032	46.00 1168	52.00 1321	14.16 360	17.09 434
021	20 FC	82.00 2083	46.00 1168	52.00 1321	14.07 357	16.00 406
021	21.56 AF	82.00 2083	52.00 1321	52.00 1321	14.16 360	17.09 434
025	24.50 FC*	86.00 2184	52.00 1321	60.00 1524	16.34 415	19.15 486
025	24 AF	86.00 2184	60.00 1524	58.00 1473	15.48 393	18.80 478
030	24.50 FC	98.00 2489	60.00 1524	60.00 1524	16.34 415	19.15 486
030	24 AF	98.00 2489	60.00 1524	58.00 1473	15.48 393	18.80 478
035	24.50 FC	102.00 2591	60.00 1524	60.00 1524	16.34 415	19.15 486
035	24 AF	102.00 2591	66.00 1676	58.00 1473	15.48 393	18.80 478
040	27.62 FC	116.00 2946	78.00 1981	74.00 1880	13.03 331	40.47 1028
040	27 AF	116.00 2946	90.00 2286	70.00 1778	13.47 342	38.45 977
050	36 FC	120.00 3048	90.00 2286	82.00 2083	13.09 333	36.22 971
050	33 AF	120.00 3048	80.00 2032	80.00 2032	14.21 361	30.00 863
065	40.25 AF	136.00 3454	80.00 2032	92.00 2337	14.09 358	34.85 987
080	40.25 AF	136.00 3454	92.00 2337	92.00 2337	14.09 358	34.85 987
085	40.25 AF	136.00 3454	98.00 2489	92.00 2337	14.09 358	34.85 987
090	40.25 AF	136.00 3454	104.00 2641	92.00 2337	14.09 358	34.85 987

\* Not available with vanes.

\*\* These are the dimensions of the unit only. A standard base rail adds 8" (203 mm) to the width, and between 4" to 12" (102 mm to 305 mm) to the unit height. A 6" (152 mm) base rail is mandatory on unit sizes 025-065. An 8" (203 mm) base rail is mandatory on unit sizes 080 and larger.

### Downblast Housed Fan Discharge

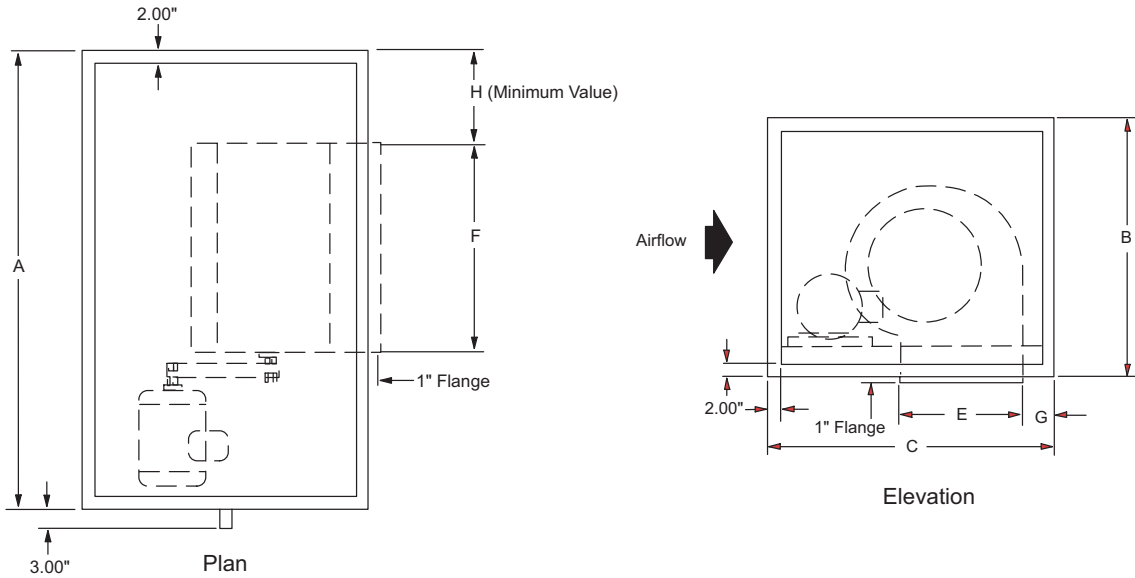

Note: The H dimension shown is the minimum value. This dimension varies with the motor size used.

Table 27: Fan Opening Dimensions—Models 003 to 090

Models 003 to 035			
	Fan dia. (Inches)	E, In. (mm)	F, In. (mm)
FC	9 × 4	11.05 (281)	7.61 (193)
	9 × 7	11.05 (281)	9.99 (254)
	9 × 9	11.05 (281)	12.61 (320)
	10.62	12.18 (309)	13.92 (354)
	12.62	14.24 (362)	16.42 (417)
	15	16.68 (424)	19.42 (493)
	18	19.68 (500)	22.68 (576)
	20	27.27 (693)	28.98 (736)
	22.25	29.51 (750)	32.23 (819)
	24.5	32.51 (826)	35.45 (900)
Models 040 to 090			
	Fan dia. (Inches)	E, In. (mm)	F, In. (mm)
Airfoil	13.22	16.68 (424)	19.94 (506)
	14.56	20.18 (513)	22.00 (559)
	16.19	22.37 (568)	24.31 (617)
	19.69	24.13 (613)	29.70 (754)
	21.56	27.27 (693)	32.45 (824)
	24	29.51 (750)	35.95 (913)
Models 040 to 090			
	Fan dia. (Inches)	E, In. (mm)	F, In. (mm)
FC	20	25.55 (649)	25.55 (649)
	22.38	28.05 (712)	28.05 (712)
	25	32.05 (814)	32.05 (814)
	27.62	35.05 (890)	35.05 (890)
	30.25	37.55 (954)	37.55 (954)
	33	43.74 (1111)	40.55 (1030)
	36	43.74 (1111)	43.55 (1106)
Models 040 to 090			
	Fan dia. (Inches)	E, In. (mm)	F, In. (mm)
Airfoil	20	22.05 (560)	29.49 (749)
	22.25	24.43 (621)	32.18 (817)
	24.5	26.74 (679)	35.68 (90)
	27	29.43 (748)	39.11 (993)
	30	32.61 (828)	43.24 (1098)
	33	35.74 (908)	47.99 (1219)
	36.5	39.49 (1003)	52.55 (1335)
40.25	43.36 (1101)	58.30 (1481)	

**Table 28: Downblast Housed Fan Dimensions**

Unit size	Fan diameter (Inches)	A** In. (mm)	B** In. (mm)	C In. (mm)	G In. (mm)	H (minimum) In. (mm)
003	9 × 4, 9 × 7 FC*	38.00 (965)	26.00 (660)	36.00 (914)	6.43 (163)	8.18 (208)
004	9 × 7, 9 × 9 FC*	40.00 (1016)	30.00 (762)	36.00 (914)	6.43 (163)	8.18 (208)
006	10.62 FC*	52.00 (1321)	30.00 (762)	40.00 (1016)	8.50 (216)	9.43 (240)
008	15 FC	58.00 (1473)	34.00 (864)	46.00 (1168)	8.50 (216)	12.50 (318)
008	13.22 AF	58.00 (1473)	34.00 (864)	44.00 (1118)	8.50 (216)	11.25 (286)
010	15 FC	64.00 (1626)	36.00 (914)	46.00 (1168)	8.50 (216)	12.50 (318)
010	14.56 AF	64.00 (1626)	36.00 (914)	48.00 (1219)	8.50 (216)	12.19 (310)
012	18 FC	66.00 (1676)	42.00 (1067)	50.00 (1270)	8.50 (216)	14.62 (371)
012	16.19 AF	66.00 (1676)	42.00 (1067)	52.00 (1321)	8.50 (216)	13.33 (339)
014	18 FC	74.00 (1880)	42.00 (1067)	50.00 (1270)	8.50 (216)	14.62 (371)
014	19.69 AF	74.00 (1880)	42.00 (1067)	56.00 (1422)	8.50 (216)	15.78 (401)
017	20 FC	80.00 (2032)	46.00 (1168)	56.00 (1422)	8.50 (216)	16.00 (406)
017	21.56 AF	80.00 (2032)	46.00 (1168)	58.00 (1473)	8.50 (216)	17.09 (434)
021	20 FC	82.00 (2083)	52.00 (1321)	56.00 (1422)	8.50 (216)	16.00 (406)
021	2156 AF	82.00 (2083)	52.00 (1321)	58.00 (1473)	8.50 (216)	17.09 (434)
025	24.50 FC*	86.00 (2184)	60.00 (1524)	62.00 (1575)	8.50 (216)	19.15 (486)
025	24 AF	86.00 (2184)	60.00 (1524)	62.00 (1575)	8.50 (216)	18.80 (478)
030	24.50 FC	98.00 (2489)	60.00 (1524)	62.00 (1575)	8.50 (216)	19.15 (486)
030	24 AF	98.00 (2489)	60.00 (1524)	62.00 (1575)	8.50 (216)	18.80 (478)
035	24.50 FC	102.00 (2591)	66.00 (1676)	62.00 (1575)	8.50 (216)	19.15 (486)
035	24 AF	102.00 (2591)	66.00 (1676)	62.00 (1575)	8.50 (216)	18.80 (478)
040	27.62 FC	116.00 (2946)	68.00 (1727)	74.00 (1880)	13.03 (331)	40.47 (1028)
040	27 AF	116.00 (2921)	68.00 (1727)	76.00 (1930)	13.47 (342)	38.45 (977)
050	36 FC	120.00 (3048)	80.00 (2032)	80.00 (2032)	13.09 (333)	36.22 (911)
050	33 AF	120.00 (3048)	80.00 (2032)	86.00 (2184)	14.21 (361)	30.00 (863)
065	40.25 AF	136.00 (3454)	92.00 (2337)	96.00 (2438)	14.09 (358)	34.85 (987)
080	40.25 AF	136.00 (3454)	98.00 (2489)	96.00 (2438)	12.6 (320)	34.85 (987)
085	40.25 AF	136.00 (3454)	104.00 (2641)	96.00 (2438)	12.6 (320)	34.85 (987)
090	40.25 AF	136.00 (3454)	110.00 (2794)	96.00 (2438)	12.6 (320)	34.85 (987)

\* Not available with vanes.

\*\* These are the dimensions of the unit only. A base rail adds 8" (203 mm) to the width, and between 4" to 12" (102 mm to 305 mm) to the unit height. A 6" (152 mm) base rail is mandatory on unit sizes 025 to 065. An 8" (203 mm) base rail is mandatory on unit sizes 080 and larger.

### Belt-drive Plenum Fan Discharge

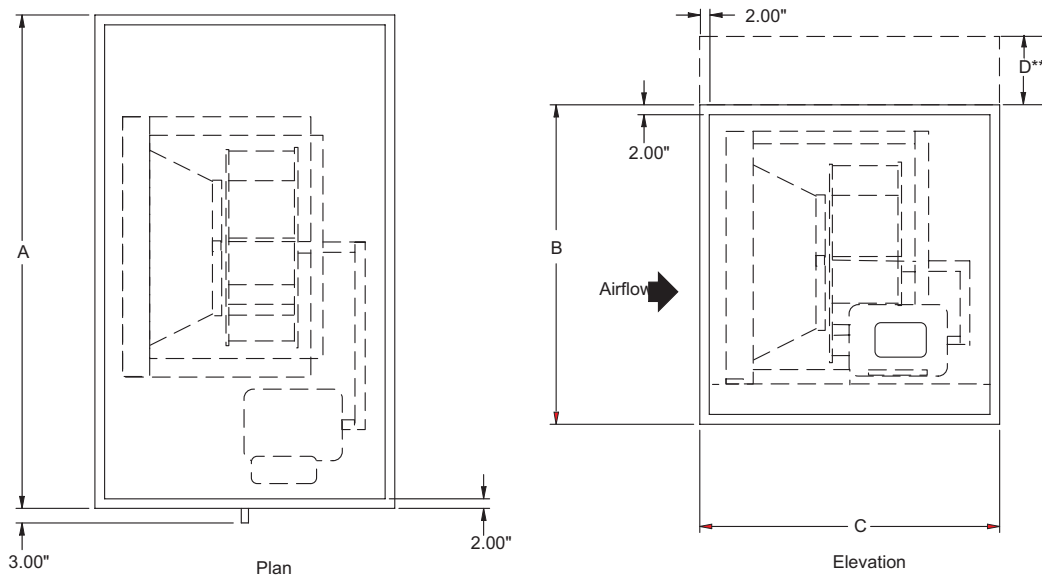

Table 29: Belt-drive Plenum Fan Dimensions

Unit size	Fan diameter (Inches)	A*, In. (mm)	B*, In. (mm)	C, In. (mm)	D**, In. (mm)
006	13.5 AF	52 (1321)	30 (762)	32 (813)	14 (356)
008	13.5 AF	58 (1473)	34 (864)	32 (813)	14 (356)
008	15.0 AF	58 (1473)	34 (864)	32 (813)	14 (356)
010	16.0 AF	64 (1626)	36 (914)	34 (864)	16 (406)
010	18.0 AF	64 (1626)	36 (914)	34 (864)	16 (406)
012	20.0 AF	66 (1676)	42 (1067)	36 (914)	18 (457)
012	22.0 AF	66 (1676)	42 (1067)	40 (1016)	18 (457)
014	20.0 AF	74 (1880)	42 (1067)	36 (914)	18 (457)
014	22.0 AF	74 (1880)	42 (1067)	40 (1016)	18 (457)
017	24.0 AF	80 (2032)	46 (1168)	42 (1067)	20 (508)
017	27.0 AF	80 (2032)	46 (1168)	44 (1118)	20 (508)
021	27.0 AF	82 (2083)	52 (1321)	44 (1118)	22 (559)
021	30.0 AF	82 (2083)	52 (1321)	48 (1219)	22 (559)
025	30.0 AF	86 (2184)	60 (1524)	48 (1219)	24 (610)
025	33.0 AF	86 (2184)	60 (1524)	50 (1270)	24 (610)
030	33.0 AF	98 (2489)	60 (1524)	50 (1270)	24 (610)
030	36.0 AF	98 (2489)	60 (1524)	54 (1372)	24 (610)
035	33.0 AF	102 (2591)	66 (1676)	50 (1270)	26 (660)
035	36.0 AF	102 (2591)	66 (1676)	54 (1372)	26 (660)
040	36.0 AF	116 (2946)	68 (1727)	54 (1372)	26 (660)
040	40.0 AF	116 (2946)	68 (1727)	52 (1321)	26 (660)
050	44.0 AF	120 (3048)	80 (2032)	56 (1422)	30 (762)
050	49.0 AF	120 (3048)	80 (2032)	60 (1524)	30 (762)
065	54.0 AF	136 (3454)	92 (2337)	64 (1626)	36 (914)
065	60.0 AF	136 (3454)	92 (2337)	68 (1727)	36 (914)
080	54.0 AF	136 (3454)	98 (2489)	64 (1626)	38 (965)
080	60.0 AF	136 (3454)	98 (2489)	68 (1727)	38 (965)
085	54.0 AF	136 (3454)	104 (2642)	64 (1626)	40 (1016)
085	60.0 AF	136 (3454)	104 (2642)	68 (1727)	40 (1016)
090	54.0 AF	136 (3454)	110 (2794)	64 (1626)	42 (1067)
090	60.0 AF	136 (3454)	110 (2794)	68 (1727)	42 (1067)

\* These are the dimensions of the unit only. A standard base rail adds 8" (203 mm) to the width, and between 4" to 12" (102 mm to 305 mm) to the unit height. A 6" (152 mm) base rail is mandatory on unit sizes 025 to 065. An 8" (203 mm) base rail is mandatory on unit sizes 080 and larger.

\*\* This value represents the height for an optional top plenum. Additional discharge openings include axial, top and single opening, opposite drive side, bottom single opening, split and removable panels. Use Daikin SelectTools software for more detailed dimensional information.

### DDPL Fan Array

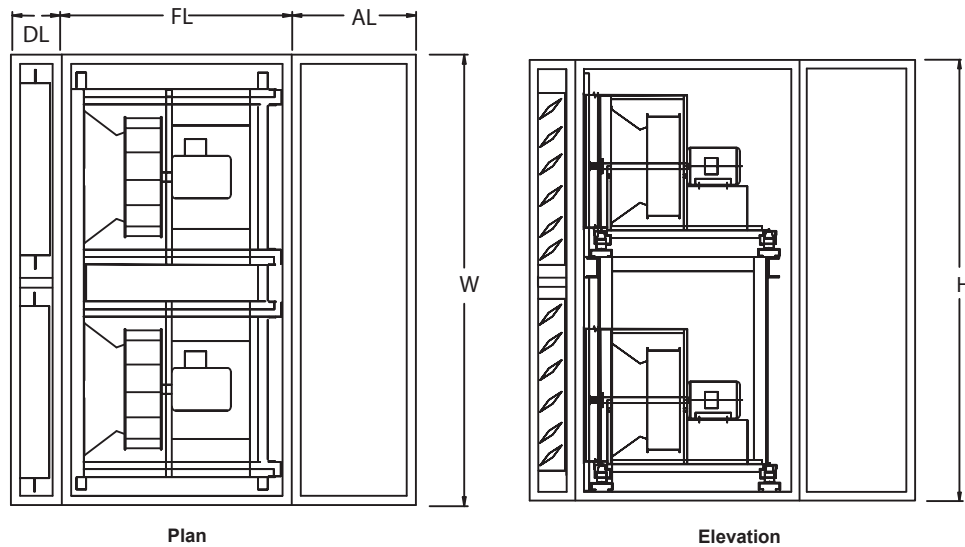

Table 30: DDPL Fan Array Minimum\* Dimensions

Fan Configuration	Wheel Size in. (mm)	DL in. (mm)	FL in. (mm)	AL in. (mm)	H in. (mm)	W in. (mm)
1×3	12 (304.8)	14 (355.6)	28 (711.2)	24 (609.6)	36 (914.4)	104 (2641.6)
	15 (381)	14 (355.6)	32 (812.8)	24 (609.6)	38 (965.2)	110 (2794)
	18 (457.2)	14 (355.6)	40 (1016)	24 (609.6)	44 (1117.6)	128 (3251.2)
	20 (508)	14 (355.6)	42 (1066.8)	24 (609.6)	46 (1168.4)	140 (3556)
	22 (558.8)	14 (355.6)	42 (1066.8)	24 (609.6)	50 (1270)	146 (3708.4)
	24 (609.6)	14 (355.6)	46 (1168.4)	24 (609.6)	52 (1320.8)	158 (4013.2)
	27 (685.8)	14 (355.6)	48 (1219.2)	30 (762)	56 (1422.4)	170 (4318)
	30 (762)	14 (355.6)	54 (1371.6)	30 (762)	60 (1524)	182 (4622.8)
2×2	12 (304.8)	14 (355.6)	28 (711.2)	24 (609.6)	68 (1727.2)	70 (1778)
	15 (381)	14 (355.6)	32 (812.8)	24 (609.6)	72 (1828.8)	74 (1879.6)
	18 (457.2)	14 (355.6)	40 (1016)	24 (609.6)	84 (2133.6)	86 (2184.4)
	20 (508)	14 (355.6)	42 (1066.8)	24 (609.6)	88 (2235.2)	94 (2387.6)
	22 (558.8)	14 (355.6)	42 (1066.8)	24 (609.6)	96 (2438.4)	98 (2489.2)
	24 (609.6)	14 (355.6)	46 (1168.4)	24 (609.6)	100 (2540)	106 (2692.4)
	27 (685.8)	14 (355.6)	48 (1219.2)	30 (762)	108 (2743.2)	114 (2895.6)
	30 (762)	14 (355.6)	54 (1371.6)	30 (762)	116 (2946.4)	122 (3098.8)
2×3	12 (304.8)	14 (355.6)	28 (711.2)	24 (609.6)	68 (1727.2)	104 (2641.6)
	15 (381)	14 (355.6)	32 (812.8)	24 (609.6)	72 (1828.8)	110 (2794)
	18 (457.2)	14 (355.6)	40 (1016)	24 (609.6)	84 (2133.6)	128 (3251.2)
	20 (508)	14 (355.6)	42 (1066.8)	24 (609.6)	88 (2235.2)	140 (3556)
	22 (558.8)	14 (355.6)	42 (1066.8)	24 (609.6)	96 (2438.4)	146 (3708.4)
	24 (609.6)	14 (355.6)	46 (1168.4)	24 (609.6)	100 (2540)	158 (4013.2)
	27 (685.8)	14 (355.6)	48 (1219.2)	30 (762)	108 (2743.2)	170 (4318)
	30 (762)	14 (355.6)	54 (1371.6)	30 (762)	116 (2946.4)	182 (4622.8)
33 (838.2)	14 (355.6)	54 (1371.6)	30 (762)	116 (2946.4)	182 (4622.8)	

Note: Other configurations available. Consult local Daikin sales representative for selection

\* Minimum dimensions may reflect a variable geometric aspect ratio. Use the next size larger width or height for a standard aspect ratio.

ECM Fan Array

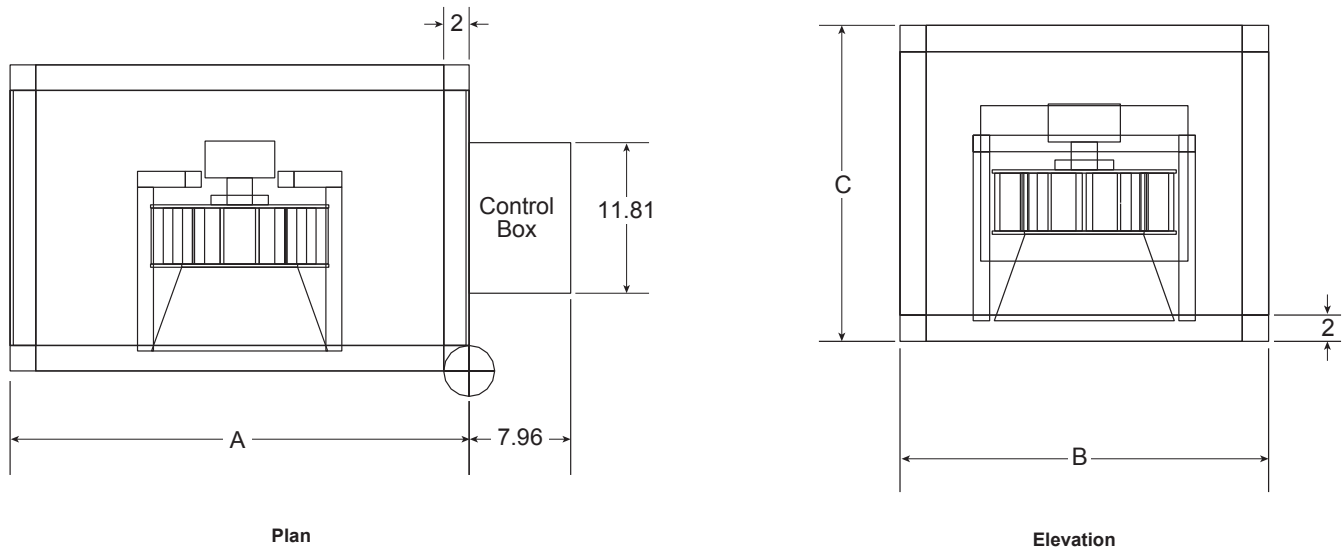
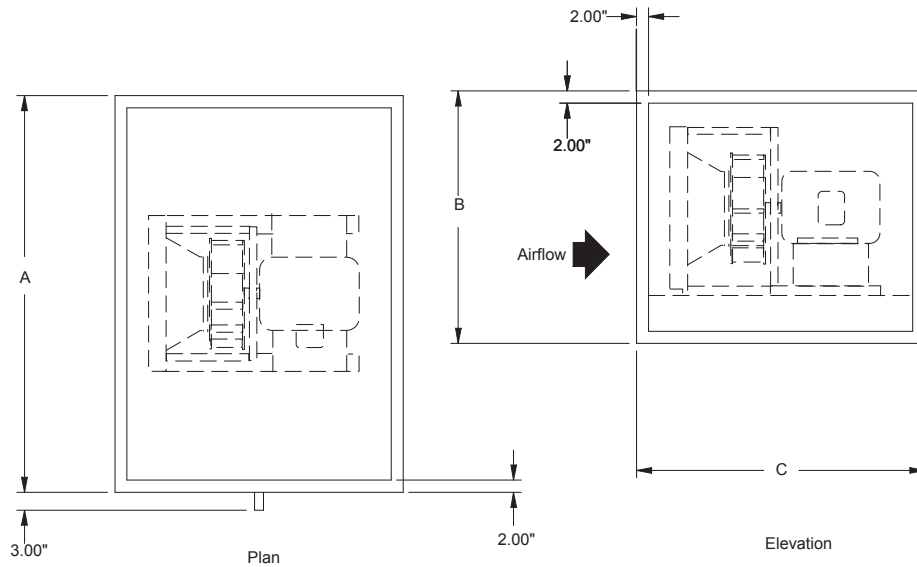

Table 31: ECM Fan Array Minimum Dimensions

Unit Size	Fan Diameter (mm)	A - In. (mm)	B - In. (mm)	C - In. (mm)
004	355	40 (1016)	30 (762)	24 (610)
006	355	52 (1321)	30 (762)	24 (610)
006	450	52 (1321)	30 (762)	30 (762)
008	355	58 (1473)	34 (864)	24 (610)
008	450	58 (1473)	34 (864)	30 (762)
010	355	64 (1626)	36 (914)	24 (610)
010	450	64 (1626)	36 (914)	30 (762)
012	355	66 (1676)	42 (1067)	24 (610)
012	450	66 (1676)	42 (1067)	30 (762)
014	355	74 (1880)	42 (1067)	24 (610)
014	450	74 (1880)	42 (1067)	30 (762)
017	355	80 (2032)	46 (1168)	24 (610)
017	450	80 (2032)	46 (1168)	30 (762)
021	355	82 (2083)	52 (1321)	24 (610)
021	450	82 (2083)	52 (1321)	30 (762)
025	355	86 (2184)	60 (1524)	24 (610)
025	450	86 (2184)	60 (1524)	30 (762)
030	355	98 (2489)	60 (1524)	24 (610)
030	450	98 (2489)	60 (1524)	30 (762)
035	355	102 (2591)	66 (1676)	24 (610)
035	450	102 (2591)	66 (1676)	30 (762)
040	355	116 (2946)	68 (1727)	24 (610)
040	450	116 (2946)	68 (1727)	30 (762)
050	355	120 (3048)	80 (2032)	24 (610)
050	450	120 (3048)	80 (2032)	30 (762)
065	355	136 (3454)	92 (2337)	24 (610)
065	450	136 (3454)	92 (2337)	30 (762)
080	355	136 (3454)	98 (2489)	24 (610)
080	450	136 (3454)	98 (2489)	30 (762)
085	355	136 (3454)	104 (2642)	24 (610)
085	450	136 (3454)	104 (2642)	30 (762)
090	355	136 (3454)	110 (2794)	24 (610)
090	450	136 (3454)	110 (2794)	30 (762)



### Direct-Drive Plenum Fan Discharge

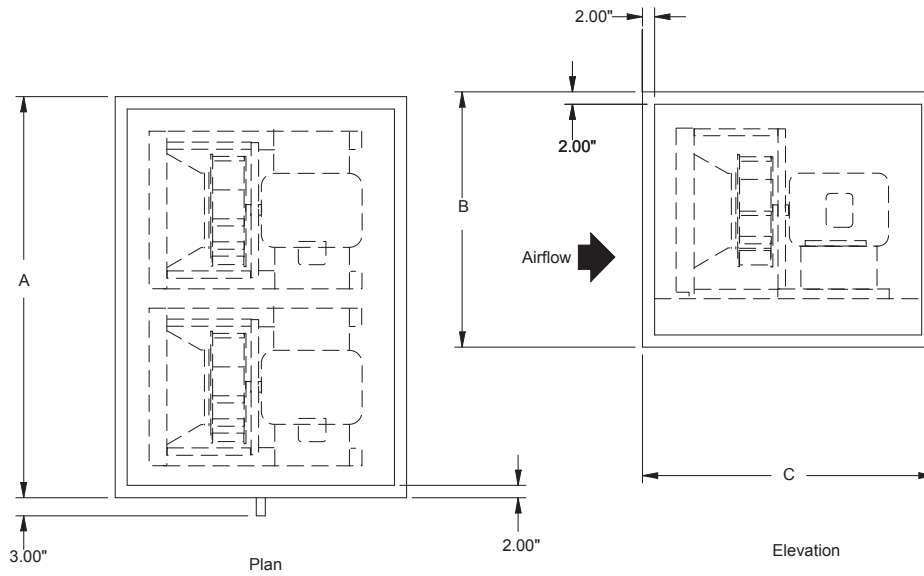

**Table 32: Direct-drive Plenum Fan Dimensions**

Unit size	Fan Diameter	A*, In. (mm)	B*, In. (mm)	C**, In. (mm)
004	11 AF	40 (1016)	30 (762)	28 (711)
004	12 AF	40 (1016)	30 (762)	30 (762)
006	12 AF	52 (1321)	30 (762)	30 (762)
006	15 AF	52 (1321)	30 (762)	34 (864)
008	15 AF	58 (1473)	34 (864)	34 (864)
008	16 AF	58 (1473)	34 (864)	40 (1016)
010	16 AF	64 (1626)	36 (914)	40 (1016)
010	18 AF	64 (1626)	36 (914)	44 (1118)
012	20 AF	66 (1676)	42 (1067)	44 (1118)
012	22 AF	66 (1676)	42 (1067)	46 (1168)
014	20 AF	74 (1880)	42 (1067)	44 (1118)
014	22 AF	74 (1880)	42 (1067)	46 (1168)
017	24 AF	80 (2032)	46 (1168)	50 (1270)
017	27 AF	80 (2032)	46 (1168)	56 (1422)
021	27 AF	82 (2083)	52 (1321)	56 (1422)
021	30 AF	82 (2083)	52 (1321)	56 (1422)
025	30 AF	86 (2184)	60 (1524)	56 (1422)
025	36 AF	68 (1727)	60 (1524)	62 (1575)
030	30 AF	98 (2489)	60 (1524)	56 (1422)
030	36 AF	98 (2489)	60 (1524)	62 (1575)
035	33 AF	102 (2591)	66 (1676)	60 (1524)
035	36 AF	102 (2591)	66 (1676)	62 (1575)
040	36 AF	116 (2946)	68 (1727)	62 (1575)
040	40 AF	116 (2946)	68 (1727)	70 (1778)
050	44 AF	120 (3048)	80 (2032)	74 (1880)
065	44 AF	136 (3454)	92 (2337)	74 (1880)
080	44 AF	136 (3454)	98 (2489)	74 (1880)
085	44 AF	136 (3454)	104 (2642)	74 (1880)
090	44 AF	136 (3454)	110 (2794)	74 (1880)

\* These are the dimensions of the unit only. A standard base rail adds 8" (203 mm) to the width, and between 4" to 12" (102 mm to 305 mm) to the unit height.  
 A 6" (152 mm) base rail is mandatory on unit sizes 025 to 065. An 8" (203 mm) base rail is mandatory on unit sizes 080 and larger.  
 \*\* This value is dependent on motor frame size.

### Dual Direct-drive Plenum Fan Discharge



**Table 33: Dual Direct-drive Plenum Fan Dimensions**

Unit size	Fan Diameter	A*, In. (mm)	B*, In. (mm)	C**, In. (mm)
004	11 AF	80 (2032)	30 (762)	28 (711)
004	12 AF	80 (2032)	30 (762)	30 (762)
006	12 AF	104 (2642)	30 (762)	30 (762)
006	15 AF	104 (2642)	30 (762)	34 (864)
008	15 AF	116 (2946)	34 (864)	34 (864)
008	16 AF	116 (2946)	34 (864)	40 (1016)
010	16 AF	128 (3251)	36 (914)	40 (1016)
010	18 AF	128 (3251)	36 (914)	44 (1118)
012	20 AF	132 (3353)	42 (1067)	44 (1118)
012	22 AF	132 (3353)	42 (1067)	46 (1168)
014	20 AF	148 (3759)	42 (1067)	44 (1118)
014	22 AF	148 (3759)	42 (1067)	46 (1168)
017	24 AF	160 (4064)	46 (1168)	50 (1270)
017	27 AF	160 (4064)	46 (1168)	56 (1422)
021	27 AF	164 (4166)	52 (1321)	56 (1422)
021	30 AF	164 (4166)	52 (1321)	56 (1422)
025	30 AF	172 (4369)	60 (1524)	56 (1422)
025	36 AF	136 (3454)	60 (1524)	62 (1575)
030	30 AF	196 (4978)	60 (1524)	56 (1422)
030	36 AF	196 (4978)	60 (1524)	62 (1575)
035	33 AF	204 (5182)	66 (1676)	60 (1524)
035	36 AF	204 (5182)	66 (1676)	62 (1575)
040	36 AF	232 (5893)	68 (1727)	62 (1575)
040	40 AF	232 (5893)	68 (1727)	70 (1778)
050	44 AF	240 (6096)	80 (2032)	74 (1880)
065	44 AF	272 (6909)	92 (2337)	74 (1880)
080	44 AF	272 (6909)	98 (2489)	74 (1880)
085	44 AF	272 (6909)	104 (2642)	74 (1880)
090	44 AF	272 (6909)	110 (2794)	74 (1880)

\* These are the dimensions of the unit only. A standard base rail adds 8" (203 mm) to the width, and between 4" to 12" (102 mm to 305 mm) to the unit height.  
 A 6" (152 mm) base rail is mandatory on unit sizes 025 to 065. An 8" (203 mm) base rail is mandatory on unit sizes 080 and larger.  
 \*\* This value is dependent on motor frame size.

### Inline Fan Discharge

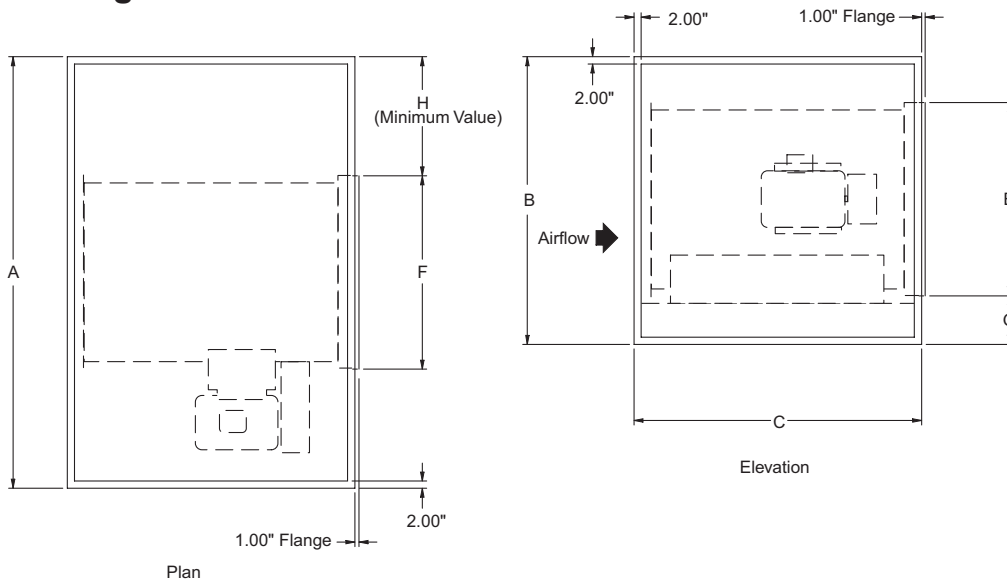

Table 34: Inline Fan Dimensions

Unit size	Fan Diameter	A* In. (mm)	B* In. (mm)	C In. (mm)	E In. (mm)	F In. (mm)	G In. (mm)	H (minimum) In. (mm)
012	150 Inline	66.0 (1676)	42.0 (1067)	42.0 (1067)	27.80 (706)	25.80 (655)	8.10 (206)	20.10 (511)
012	165 Inline	66.0 (1676)	42.0 (1067)	44.0 (1118)	29.80 (757)	27.80 (706)	8.10 (206)	18.10 (460)
014	150 Inline	74.0 (1880)	42.0 (1067)	42.0 (1067)	27.80 (706)	25.80 (655)	8.10 (206)	24.10 (612)
014	165 Inline	74.0 (1880)	42.0 (1067)	44.0 (1118)	29.80 (757)	27.80 (706)	8.10 (206)	22.10 (561)
017	165 Inline	80.0 (2032)	46.0 (1168)	44.0 (1118)	29.80 (757)	27.80 (706)	8.10 (206)	26.10 (663)
017	182 Inline	80.0 (2032)	46.0 (1168)	48.0 (1219)	31.80 (808)	31.80 (808)	8.10 (206)	24.10 (612)
021	200 Inline	82.0 (2083)	52.0 (1321)	50.0 (1270)	33.80 (859)	35.80 (909)	8.10 (206)	14.10 (358)
021	222 Inline	82.0 (2083)	52.0 (1321)	54.0 (1372)	35.80 (909)	35.80 (909)	10.10 (257)	16.10 (409)
025	245 Inline	86.0 (2184)	60.0 (1524)	58.0 (1473)	41.80 (1062)	39.80 (1011)	8.10 (206)	16.10 (409)
025	270 Inline	86.0 (2184)	60.0 (1524)	64.0 (1626)	43.80 (1113)	43.80 (1113)	12.10 (307)	14.10 (358)
030	245 Inline	98.0 (2489)	60.0 (1524)	58.0 (1473)	41.80 (1062)	39.80 (1011)	8.10 (206)	28.10 (714)
030	270 Inline	98.0 (2489)	60.0 (1524)	64.0 (1626)	43.80 (1113)	43.80 (1113)	12.10 (307)	20.10 (511)
035	270 Inline	102.0 (2591)	66.0 (1676)	64.0 (1626)	43.80 (1113)	43.80 (1113)	12.10 (307)	28.10 (714)
035	300 Inline	102.0 (2591)	66.0 (1676)	70.0 (1778)	47.80 (1214)	47.80 (1214)	12.10 (307)	20.10 (511)
040	270 Inline	116.0 (2946)	68.0 (1727)	66.0 (1676)	43.80 (1113)	43.80 (1113)	12.10 (307)	36.10 (917)
040	300 Inline	116.0 (2946)	68.0 (1727)	70.0 (1778)	49.80 (1265)	47.80 (1214)	12.10 (307)	34.10 (866)
050	365 Inline	120.0 (3048)	80.0 (2032)	82.0 (2083)	57.80 (1468)	57.80 (1468)	12.10 (307)	30.10 (765)
050	402 Inline	120.0 (3048)	80.0 (2032)	90.0 (2286)	63.80 (1621)	63.80 (1621)	12.10 (307)	22.10 (561)
065	402 Inline	136.0 (3454)	92.0 (2337)	90.0 (2286)	63.80 (1621)	63.80 (1621)	12.10 (307)	36.10 (917)
065	445 Inline	136.0 (3454)	92.0 (2337)	96.0 (2438)	69.80 (1773)	69.80 (1773)	12.10 (307)	32.10 (815)
080	402 Inline	136.0 (3454)	98.0 (2489)	90.0 (2286)	63.80 (1621)	63.80 (1621)	12.10 (307)	36.10 (917)
080	445 Inline	136.0 (3454)	98.0 (2489)	96.0 (2438)	69.80 (1773)	69.80 (1773)	12.10 (307)	32.10 (815)
085	402 Inline	136.0 (3454)	104.0 (2642)	90.0 (2286)	63.80 (1621)	63.80 (1621)	12.10 (307)	36.10 (917)
085	445 Inline	136.0 (3454)	104.0 (2642)	96.0 (2438)	69.80 (1773)	69.80 (1773)	12.10 (307)	32.10 (815)
090	402 Inline	136.0 (3454)	110.0 (2794)	90.0 (2286)	63.80 (1621)	63.80 (1621)	12.10 (307)	36.10 (917)
090	445 Inline	136.0 (3454)	110.0 (2794)	96.0 (2438)	69.80 (1773)	69.80 (1773)	12.10 (307)	32.10 (815)

\* These are the dimensions of the unit only. A standard base rail adds 8" (203 mm) to the width, and between 4" to 12" (102 mm to 305 mm) to the unit height.  
 A 6" (152 mm) base rail is mandatory on unit sizes 025-065. An 8" (203 mm) base rail is mandatory on unit sizes 080 and larger.

# Coil Section

## Cooling Coil Section

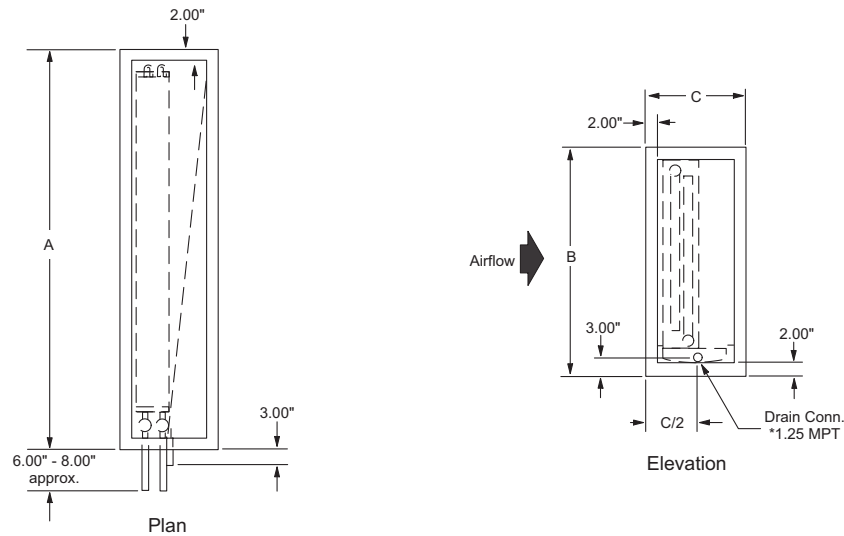

The single cooling coil section is available in numerous depths. This provides the option of varying the amount of space downstream from the coil for access to inspect and clean the coil and drain pan. When using a single bank of coils, the 18" deep section holds up to a 4-row water or DX coil.

Also available are staggered cooling coils. The staggered arrangement maximizes the cooling coil face area by providing two banks of coils. These two coils are not stacked, but are staggered in the direction of airflow. This configuration does require more section depth in the direction of airflow. Staggered coils are only available on unit sizes 025 and larger.

The section depth required varies between 30" to 54". This depends on the unit size and number of rows in the coil.

When a coil section is used in a vertical application, the section must be deep enough to support the fan above it and keep the face velocity through the top opening below 1000 fpm. The coil section should be a minimum of 36" deep in direction of airflow. As the fan and airflow get larger, it may be necessary to add a plenum downstream from the coil section. Drain connections for units with width A greater than 108", in Table 37, are 1.50 MPT.\*

**Table 35: Cooling Coil Dimensions**

Unit size	A* (large, medium coils) In. (mm)	A* (extended coils) In. (mm)	B* In. (mm)	18" - 54" In. (mm)
003	38.0 (965)	44.0 (1118)	26.0 (660)	18.0 (457) to 54.0 (1372) In 2" increments
004	40.0 (1016)	46.0 (1168)	30.0 (762)	
006	52.0 (1321)	58.0 (1473)	30.0 (762)	
008	58.0 (1473)	64.0 (1626)	34.0 (864)	
010	64.0 (1626)	70.0 (1778)	36.0 (914)	
012	66.0 (1676)	72.0 (1829)	42.0 (1067)	
014	74.0 (1880)	80.0 (2032)	42.0 (1067)	
017	80.0 (2032)	86.0 (2184)	46.0 (1168)	
021	82.0 (2083)	88.0 (2235)	52.0 (1321)	
025	86.0 (2184)	N/A	60.0 (1524)	
030	98.0 (2489)	N/A	60.0 (1524)	
035	102.0 (2591)	N/A	66.0 (1676)	
040	116.0 (2946)	N/A	68.0 (1727)	
050	120.0 (3048)	N/A	80.0 (2032)	
065	136.0 (3454)	N/A	92.0 (2337)	
080	136.0 (3454)	N/A	98.0 (2489)	
085	136.0 (3454)	N/A	104.0 (2642)	
090	136.0 (3454)	N/A	110.0 (2794)	

\* These are the dimensions of the unit only. A standard base rail adds 8" (203 mm) to the width, and between 4" to 12" (102 mm to 305 mm) to the unit height. A 6" (152 mm) base rail is mandatory on unit sizes 025 to 065. An 8" (203 mm) base rail is mandatory on unit sizes 080 and larger.

### Combination Cooling and Reheat Coil Section

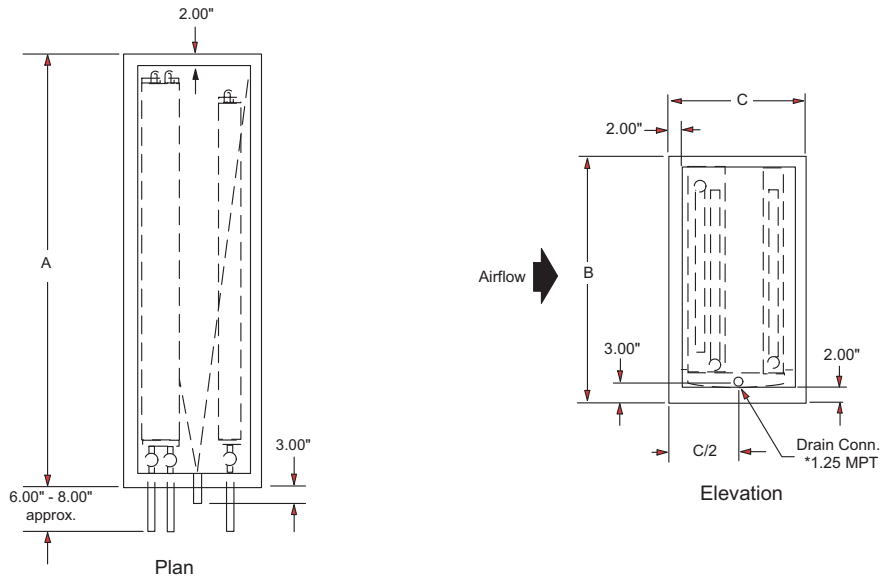

The combination cooling and reheat coil section is available in numerous depths. This provides the option of varying the amount of space between the cooling coil and reheat coil for access to inspect and clean the coil and drain pan. All reheat and most cooling coils are arranged in a single bank, which can be 1, 2 or 3 coils high. When using a single bank of cooling coils, the 24" deep section holds up to a 4-row water or DX coil, and a 1-row or 2-row heating coil. A 36" deep section holds a 12-row water coil and a 1 or 2-row reheat coil.

Also available are staggered cooling coils. The staggered arrangement maximizes the cooling coil face area by providing

two banks of coils. These two coils are not stacked, but are staggered in the direction of airflow. This configuration does require more section depth in the direction of airflow. Staggered coils are available only on unit sizes 025 and larger. The section depth required varies between 30" to 54". This depends on the unit size and number of rows in the coil.

When a combination coil section is used in a vertical application, a plenum must be provided on the leaving air side of the coil. The plenum is used for discharging air into the bottom of the fan section. Drain connections for units with width A greater than 108", in Table 38, are 1.50 MPT.\*

**Table 36: Combination Cooling and Reheat Coil Dimensions**

Unit size	A* (large, medium coils) In. (mm)	A* (extended coils) In. (mm)	B* In. (mm)	18" – 54" In. (mm)
003	38.0 (965)	44.0 (1118)	26.0 (660)	18.0 (457) to 54.0 (1372) In 2" increments
004	40.0 (1016)	46.0 (1168)	30.0 (762)	
006	52.0 (1321)	58.0 (1473)	30.0 (762)	
008	58.0 (1473)	64.0 (1626)	34.0 (864)	
010	64.0 (1626)	70.0 (1778)	36.0 (914)	
012	66.0 (1676)	72.0 (1829)	42.0 (1067)	
014	74.0 (1880)	80.0 (2032)	42.0 (1067)	
017	80.0 (2032)	86.0 (2184)	46.0 (1168)	
021	82.0 (2083)	88.0 (2235)	52.0 (1321)	
025	86.0 (2184)	N/A	60.0 (1524)	
030	98.0 (2489)	N/A	60.0 (1524)	
035	102.0 (2591)	N/A	66.0 (1676)	
040	116.0 (2946)	N/A	68.0 (1727)	
050	120.0 (3048)	N/A	80.0 (2032)	
065	136.0 (3454)	N/A	92.0 (2337)	
080	136.0 (3454)	N/A	98.0 (2489)	
085	136.0 (3454)	N/A	104.0 (2642)	
090	136.0 (3454)	N/A	110.0 (2794)	

\* These are the dimensions of the unit only. A standard base rail adds 8" (203 mm) to the width, and between 4" to 12" (102 mm to 305 mm) to the unit height. A 6" (152 mm) base rail is mandatory on unit sizes 025-065. An 8" (203 mm) base rail is mandatory on unit sizes 080 and larger.

# Heating Coil Section

1 and 2 row heating coil section  
(uncased coils)

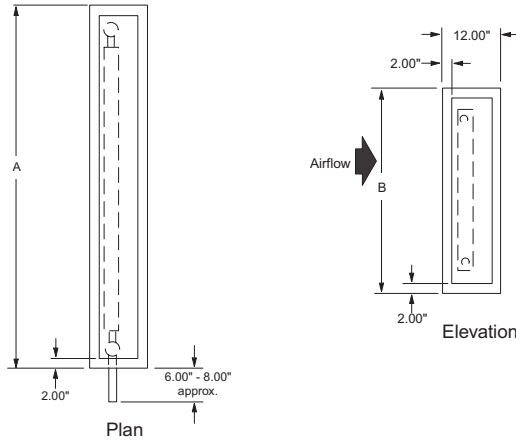

3 and 4 row heating coil section  
(cased coils)

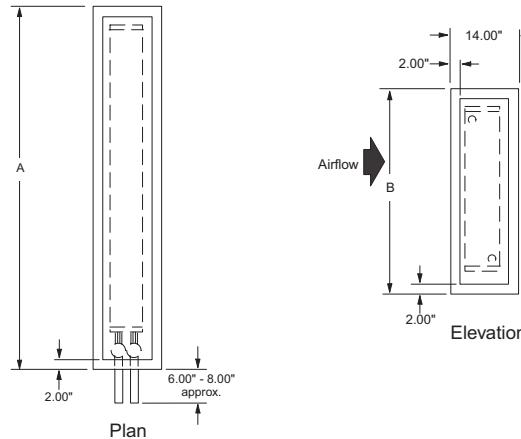

Note: 1.25 MPT drain connections are available as an option for heating coil sections.

**Table 37: Heating Coil Dimensions\***

Unit size	A, In. (mm)	B, In. (mm)
003	38.0 (965)	26.0 (660)
004	40.0 (1016)	30.0 (762)
006	52.0 (1321)	30.0 (762)
008	58.0 (1473)	34.0 (864)
010	64.0 (1626)	36.0 (914)
012	66.0 (1676)	42.0 (1067)
014	74.0 (1880)	42.0 (1067)
017	80.0 (2032)	46.0 (1168)
021	82.0 (2083)	52.0 (1321)
025	86.0 (2184)	60.0 (1524)
030	98.0 (2489)	60.0 (1524)
035	102.0 (2591)	66.0 (1676)
040	116.0 (2946)	68.0 (1727)
050	120.0 (3048)	80.0 (2032)
065	136.0 (3454)	92.0 (2337)
080	136.0 (3454)	98.0 (2489)
085	136.0 (3454)	104.0 (2642)
090	136.0 (3454)	110.0 (2794)

\* These are the dimensions of the unit only. A standard base rail adds 8" (203 mm) to the width and between 4" to 12" (102 mm to 305 mm) to the unit height. A base rail is mandatory on unit sizes 025 to 065 and adds a minimum of 6" (152 mm) to the unit height. Unit sizes greater than 080 require a base rail that adds a minimum of 8" (203 mm to 305 mm) to the unit height.

### Horizontal Discharge Two-Deck Multi-zone Coil Section

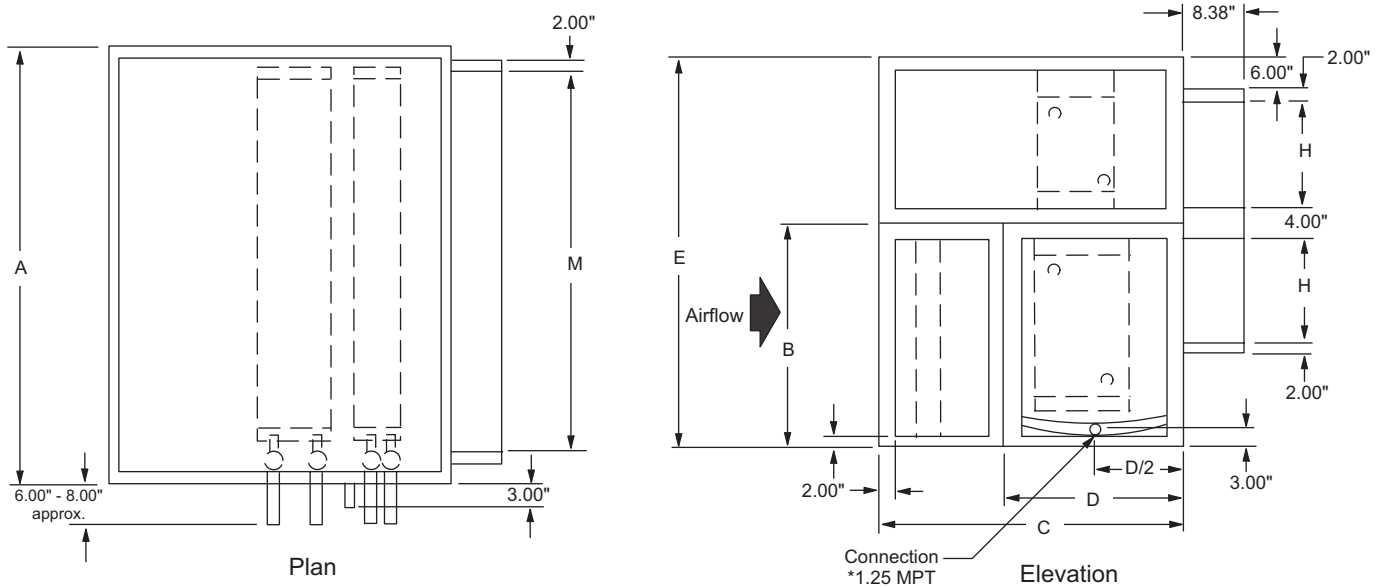

\*Drain connection for units with width (A) greater than 108" are 1.50 MPT.

**Table 38: Horizontal Discharge Two-Deck Multi-zone Coil Dimensions**

Unit size	Max # of zones	A*, In. (mm)	B, In. (mm)	C**, In. (mm)	D**, In. (mm)	E*, In. (mm)	H, In. (mm)	M, In. (mm)
006	5	52.0 (1321)	30.0 (762)	40.0 (1016)	24.0 (610)	52.0 (1321)	12.0 (305)	40.60 (1031)
008	6	58.0 (1473)	34.0 (864)	42.0 (1067)	24.0 (610)	58.0 (1473)	14.0 (356)	48.60 (1234)
010	7	64.0 (1626)	36.0 (914)	42.0 (1067)	24.0 (610)	60.0 (1524)	14.0 (356)	56.60 (1438)
012	7	66.0 (1676)	42.0 (1067)	52.0 (1321)	30.0 (762)	70.0 (1778)	18.0 (457)	56.60 (1438)
014	8	74.0 (1880)	42.0 (1067)	52.0 (1321)	30.0 (762)	70.0 (1778)	18.0 (457)	64.60 (1641)
017	9	80.0 (2032)	46.0 (1168)	54.0 (1372)	30.0 (762)	76.0 (1930)	20.0 (508)	72.60 (1844)
021	9	82.0 (2083)	52.0 (1321)	56.0 (1422)	30.0 (762)	84.0 (2134)	22.0 (559)	72.60 (1844)
025	9	86.0 (2184)	60.0 (1524)	60.0 (1524)	30.0 (762)	96.0 (2438)	26.0 (660)	72.60 (1844)
030	11	98.0 (2489)	60.0 (1524)	60.0 (1524)	30.0 (762)	96.0 (2438)	26.0 (660)	88.60 (2250)
035	11	102.0 (2591)	66.0 (1676)	70.0 (1778)	36.0 (914)	106.0 (2692)	30.0 (762)	88.60 (2250)
040	13	116.0 (2946)	68.0 (1727)	70.0 (1778)	36.0 (914)	108.0 (2743)	30.0 (762)	104.60 (2657)
050	14	120.0 (3048)	80.0 (2032)	76.0 (1930)	36.0 (914)	126.0 (3200)	36.0 (914)	112.60 (2860)
065	16	136.0 (3454)	92.0 (2337)	88.0 (2235)	42.0 (1067)	144.0 (3658)	42.0 (1067)	128.60 (3266)
080	N/A	N/A	N/A	N/A	N/A	N/A	N/A	N/A
085	N/A	N/A	N/A	N/A	N/A	N/A	N/A	N/A
090	N/A	N/A	N/A	N/A	N/A	N/A	N/A	N/A

\* These are the dimensions of the unit only. A standard base rail adds 8" (203 mm) to the width, and between 4" to 12" (102 mm to 305 mm) to the unit height. A 6" (152 mm) base rail is mandatory on unit sizes 025 to 065. An 8" (203 mm) base rail is mandatory on unit sizes 080 and larger.

\*\* This value represents the height for an optional top plenum. Additional discharge openings include axial, top and single opening, opposite drive side, bottom single opening, split and removable panels. Use Daikin SelectTools software for more detailed dimensional information.



Vertical Discharge Two-Deck Multi-zone Coil Section

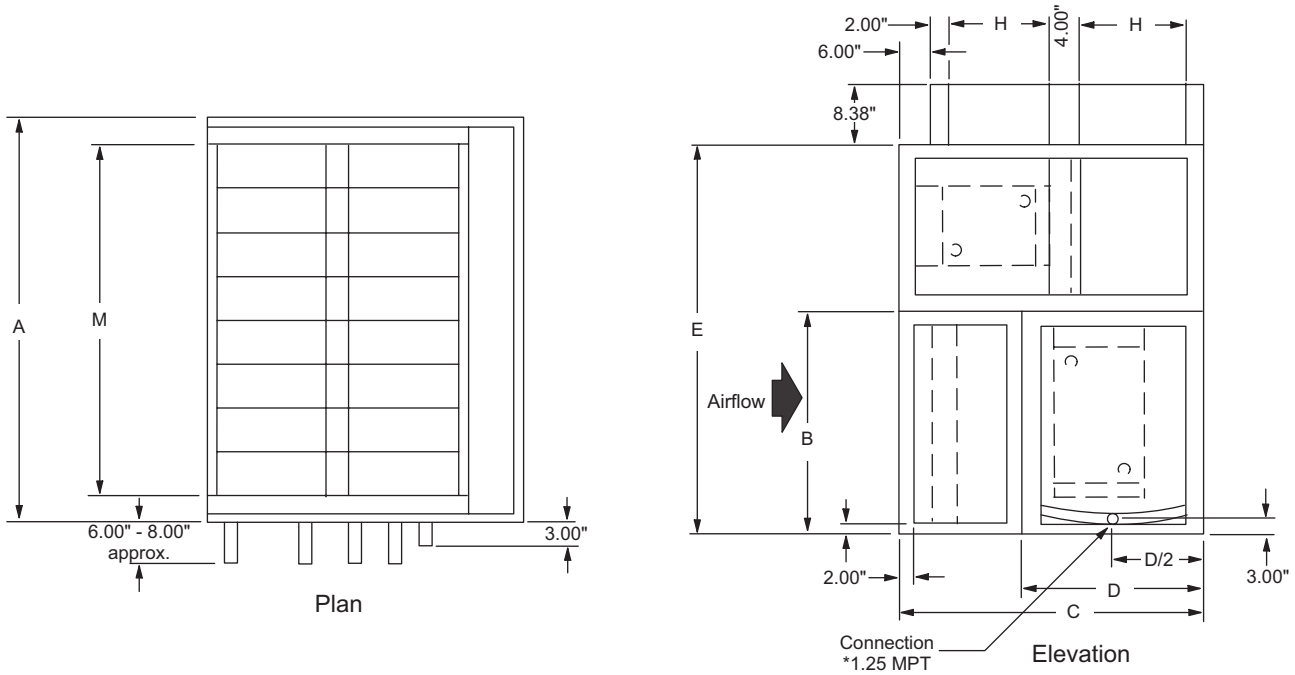

\*Drain connection for units with width (A) greater than 108\" are 1.50 MPT.

Table 39: Vertical Discharge Two-Deck Multi-zone Coil Dimensions

Unit size	Max # of zones	A* In. (mm)	B In. (mm)	C** In. (mm)	D** In. (mm)	E* In. (mm)	H In. (mm)	M In. (mm)
006	5	52.0 (1321)	30.0 (762)	46.0 (1168)	30.0 (762)	48.0 (1219)	12.0 (305)	40.60 (1031)
008	6	58.0 (1473)	34.0 (864)	48.0 (1219)	30.0 (762)	54.0 (1372)	14.0 (356)	48.60 (1234)
010	7	64.0 (1626)	36.0 (914)	48.0 (1219)	30.0 (762)	56.0 (1422)	14.0 (356)	56.60 (1438)
012	7	66.0 (1676)	42.0 (1067)	58.0 (1473)	36.0 (914)	66.0 (1676)	18.0 (457)	56.60 (1438)
014	8	74.0 (1880)	42.0 (1067)	58.0 (1473)	36.0 (914)	66.0 (1676)	18.0 (457)	64.60 (1641)
017	9	80.0 (2032)	46.0 (1168)	60.0 (1524)	36.0 (914)	72.0 (1829)	20.0 (508)	72.60 (1844)
021	9	82.0 (2083)	52.0 (1321)	62.0 (1575)	36.0 (914)	80.0 (2032)	22.0 (559)	72.60 (1844)
025	9	86.0 (2184)	60.0 (1524)	72.0 (1829)	42.0 (1067)	92.0 (2337)	26.0 (660)	72.60 (1844)
030	11	98.0 (2489)	60.0 (1524)	72.0 (1829)	42.0 (1067)	92.0 (2337)	26.0 (660)	88.60 (2250)
035	11	102.0 (2591)	66.0 (1676)	82.0 (2083)	48.0 (1219)	102.0 (2591)	30.0 (762)	88.60 (2250)
040	13	116.0 (2946)	68.0 (1727)	82.0 (2083)	48.0 (1219)	104.0 (2642)	30.0 (762)	104.60 (2657)
050	14	120.0 (3048)	80.0 (2032)	94.0 (2388)	54.0 (1372)	122.0 (3099)	36.0 (914)	112.60 (2860)
065	16	N/A	N/A	N/A	N/A	N/A	N/A	N/A
080	N/A	N/A	N/A	N/A	N/A	N/A	N/A	N/A
085	N/A	N/A	N/A	N/A	N/A	N/A	N/A	N/A
090	N/A	N/A	N/A	N/A	N/A	N/A	N/A	N/A

\* These are the dimensions of the unit only. A base rail adds 8\" (203 mm) to the width and between 4\" to 12\" (102 mm to 305 mm) to the unit height.

A base rail is mandatory on unit sizes 025 to 065 and adds a minimum of 6\" (152 mm) to the unit height. Unit sizes greater than 080 require a base rail that adds a minimum of 8\" (203 mm) to the unit height.

\*\* For 10-row water and DX coils, the C and D dimensions are 6\" longer. If additional access is required downstream from the cooling coil, refer to VisionSelectTools software for available selection options.

### Horizontal Discharge Three-Deck Multi-zone Coil Section

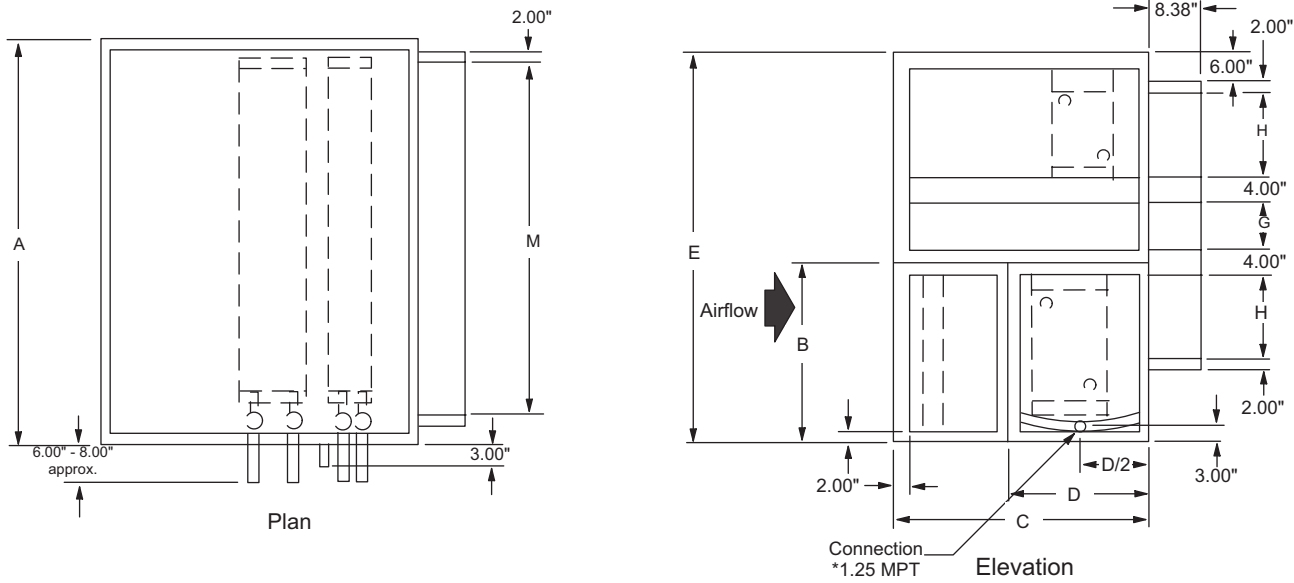

\*Drain connection for units with width (A) greater than 108\" are 1.50 MPT.

**Table 40: Horizontal Discharge Three-Deck Multi-zone Coil Dimensions**

Unit size	Max # of zones	A* In. (mm)	B** In. (mm)	C** In. (mm)	D** In. (mm)	E* In. (mm)	G In. (mm)	H In. (mm)	M In. (mm)
006	5	52.0 (1321)	30.0 (762)	40.0 (1016)	24.0 (610)	64.0 (1626)	8.0 (203)	12.0 (305)	40.60 (1031)
008	6	58.0 (1473)	34.0 (864)	42.0 (1067)	24.0 (610)	70.0 (1778)	8.0 (203)	14.0 (356)	48.60 (1234)
010	7	64.0 (1626)	36.0 (914)	42.0 (1067)	24.0 (610)	72.0 (1829)	8.0 (203)	14.0 (356)	56.60 (1438)
012	7	66.0 (1676)	42.0 (1067)	52.0 (1321)	30.0 (762)	84.0 (2134)	10.0 (254)	18.0 (457)	56.60 (1438)
014	8	74.0 (1880)	42.0 (1067)	52.0 (1321)	30.0 (762)	84.0 (2134)	10.0 (254)	18.0 (457)	64.60 (1641)
017	9	80.0 (2032)	46.0 (1168)	54.0 (1372)	30.0 (762)	92.0 (2337)	12.0 (305)	20.0 (508)	72.60 (1844)
021	9	82.0 (2083)	52.0 (1321)	56.0 (1422)	30.0 (762)	102.0 (2591)	14.0 (356)	22.0 (559)	72.60 (1844)
025	9	86.0 (2184)	60.0 (1524)	60.0 (1524)	30.0 (762)	116.0 (2946)	16.0 (406)	26.0 (660)	72.60 (1844)
030	11	98.0 (2489)	60.0 (1524)	60.0 (1524)	30.0 (762)	116.0 (2946)	16.0 (406)	26.0 (660)	88.60 (2250)
035	11	102.0 (2591)	66.0 (1676)	70.0 (1778)	36.0 (914)	128.0 (3251)	18.0 (457)	30.0 (762)	88.60 (2250)
040	13	116.0 (2946)	68.0 (1727)	70.0 (1778)	36.0 (914)	130.0 (3302)	18.0 (457)	30.0 (762)	104.60 (2657)
050	N/A	N/A	N/A	N/A	N/A	N/A	N/A	N/A	N/A
060	N/A	N/A	N/A	N/A	N/A	N/A	N/A	N/A	N/A
080	N/A	N/A	N/A	N/A	N/A	N/A	N/A	N/A	N/A
085	N/A	N/A	N/A	N/A	N/A	N/A	N/A	N/A	N/A
090	N/A	N/A	N/A	N/A	N/A	N/A	N/A	N/A	N/A

\* These are the dimensions of the unit only. A base rail adds 8\" (203 mm) to the width, and between 4\" to 2\" (102 mm to 305 mm) to the unit height. A base rail is mandatory on unit sizes 025 to 065 and adds a minimum of 6\" (152 mm) to the unit height. Unit sizes greater than 080l require a base rail that adds a minimum of 8\" (203 mm) to the unit height.  
 \*\* For 10-row water and DX coils, the C and D dimensions are 6\" longer. If additional access is required downstream from the cooling coil, refer to Daikin SelectTools software for available selection options.

### Vertical Discharge Three-Deck Multi-zone Coil Section

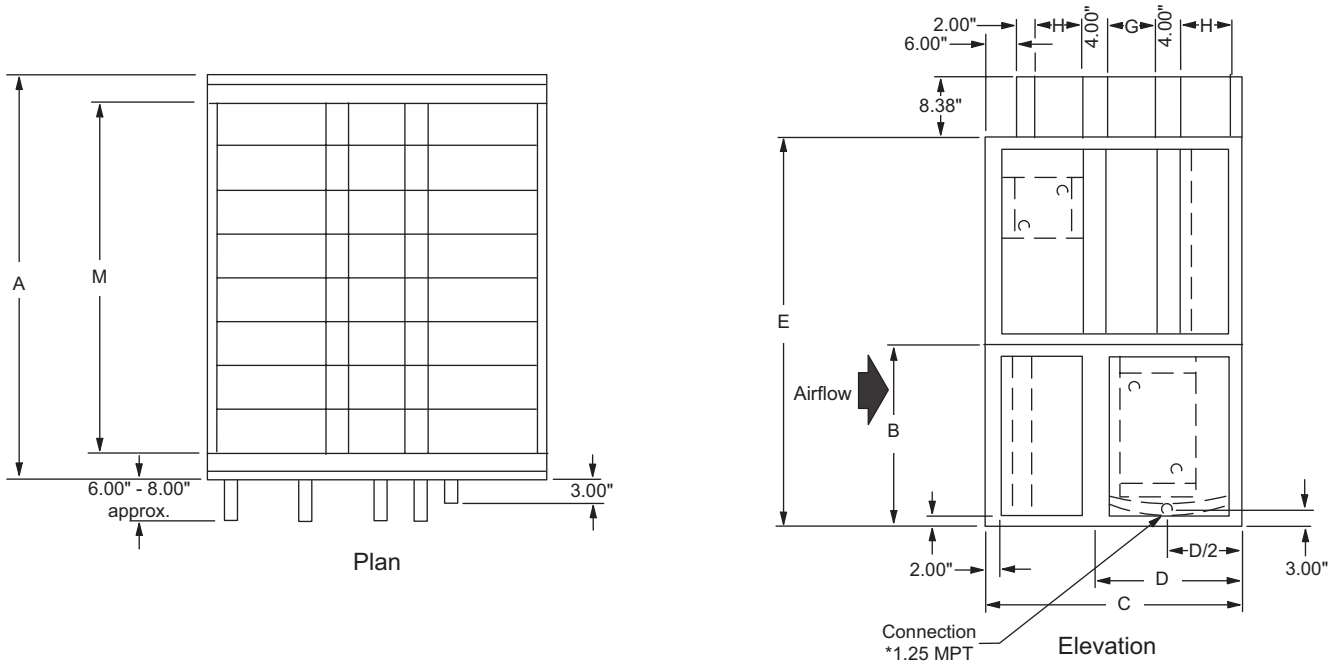

**Table 41: Vertical Discharge Three-Deck Multi-zone Coil Dimensions**

Unit size	Max # of zones	A* In. (mm)	B In. (mm)	C** In. (mm)	D** In. (mm)	E* In. (mm)	G In. (mm)	H In. (mm)	M In. (mm)
006	5	52.0 (1321)	30.0 (762)	50.0 (1270)	30.0 (762)	58.0 (1473)	8.0 (203)	12.0 (305)	40.60 (1031)
008	6	58.0 (1473)	34.0 (864)	54.0 (1372)	36.0 (914)	64.0 (1626)	8.0 (203)	14.0 (356)	48.60 (1234)
010	7	64.0 (1626)	36.0 (914)	54.0 (1372)	36.0 (914)	66.0 (1676)	8.0 (203)	14.0 (356)	56.60 (1438)
012	7	66.0 (1676)	42.0 (1067)	64.0 (1626)	36.0 (914)	76.0 (1930)	10.0 (254)	18.0 (457)	56.60 (1438)
014	8	74.0 (1880)	42.0 (1067)	64.0 (1626)	36.0 (914)	76.0 (1930)	10.0 (254)	18.0 (457)	64.60 (1641)
017	9	80.0 (2032)	46.0 (1168)	70.0 (1778)	42.0 (1067)	82.0 (2083)	12.0 (305)	20.0 (508)	72.60 (1844)
021	9	82.0 (2083)	52.0 (1321)	76.0 (1930)	42.0 (1067)	90.0 (2286)	14.0 (356)	22.0 (559)	72.60 (1844)
025	9	86.0 (2184)	60.0 (1524)	86.0 (2184)	48.0 (1219)	102.0 (2591)	16.0 (406)	26.0 (660)	72.60 (1844)
030	11	98.0 (2489)	60.0 (1524)	86.0 (2184)	48.0 (1219)	102.0 (2591)	16.0 (406)	26.0 (660)	88.60 (2250)
035	11	102.0 (2591)	66.0 (1676)	96.0 (2438)	48.0 (1219)	112.0 (2845)	18.0 (457)	30.0 (762)	88.60 (2250)
040	13	116.0 (2946)	68.0 (1727)	96.0 (2438)	48.0 (1219)	114.0 (2896)	18.0 (457)	30.0 (762)	104.60 (2657)
050	N/A	N/A	N/A	N/A	N/A	N/A	N/A	N/A	N/A
065	N/A	N/A	N/A	N/A	N/A	N/A	N/A	N/A	N/A
080	N/A	N/A	N/A	N/A	N/A	N/A	N/A	N/A	N/A
085	N/A	N/A	N/A	N/A	N/A	N/A	N/A	N/A	N/A
090	N/A	N/A	N/A	N/A	N/A	N/A	N/A	N/A	N/A

\* These are the dimensions of the unit only. A base rail adds 8" (203 mm) to the width, and between 4" to 12" (102 mm to 305 mm) to the unit height. A base rail is mandatory on unit sizes 02 to 065 and adds a minimum of 6" (152 mm) to the unit height. Unit sizes greater than 080 require a base rail that adds a minimum of 8" (203 mm) to the unit height.  
 \*\* For 10-row water and DX coils, the C and D dimensions are 6" longer. If additional access is required downstream from the cooling coil, refer to Daikin SelectTools software for available selection options.

# Filter Section

## Side Load Flat and Angular Filter Section

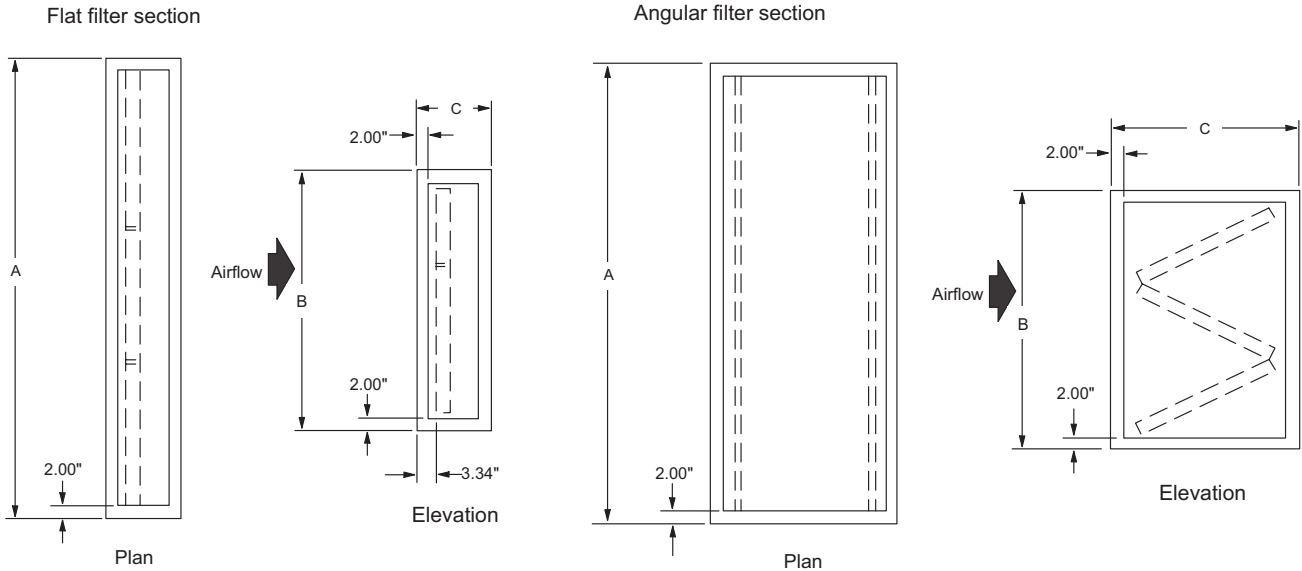

**Table 42: Side Load Flat and Angular Filter Dimensions**

Unit size	A* In. (mm)	B* In. (mm)	C, In. (mm)		
			2" and 4" flat filter	2" angular filter	4" angular filter
003	38.0 (965)	28.0 (711)	12.0 (305)	32.0 (813)	N/A
004	40.0 (1016)	32.0 (813)	12.0 (305)	30.0 (762)	N/A
006	52.0 (1321)	32.0 (813)	12.0 (305)	30.0 (762)	N/A
008	58.0 (1473)	34.0 (864)	12.0 (305)	30.0 (762)	32.0 (813)
010	64.0 (1626)	38.0 (965)	12.0 (305)	30.0 (762)	32.0 (813)
012	66.0 (1676)	44.0 (1118)	12.0 (305)	30.0 (762)	32.0 (813)
014	74.0 (1880)	44.0 (1118)	12.0 (305)	30.0 (762)	32.0 (813)
017	80.0 (2032)	46.0 (1168)	12.0 (305)	30.0 (762)	32.0 (813)
021	82.0 (2083)	52.0 (1321)	12.0 (305)	30.0 (762)	32.0 (813)
025	86.0 (2184)	60.0 (1524)	12.0 (305)	32.0 (813)	32.0 (813)
030	98.0 (2489)	60.0 (1524)	12.0 (305)	32.0 (813)	32.0 (813)
035	102.0 (2591)	66.0 (1676)	12.0 (305)	32.0 (813)	32.0 (813)
040	116.0 (2946)	68.0 (1727)	12.0 (305)	32.0 (813)	32.0 (813)
050	120.0 (3048)	80.0 (2032)	12.0 (305)	32.0 (813)	32.0 (813)
065	136.0 (3454)	92.0 (2337)	12.0 (305)	32.0 (813)	32.0 (813)
080	136.0 (3454)	98.0 (2489)	12.0 (305)	32.0 (813)	32.0 (813)
085	136.0 (3454)	104.0 (2642)	12.0 (305)	32.0 (813)	32.0 (813)
090	136.0 (3454)	110.0 (2794)	12.0 (305)	32.0 (813)	32.0 (813)

\* These are the dimensions of the unit only. A standard base rail adds 8" (203 mm) to the width, and between 4" to 12" (102 mm to 305 mm) to the unit height. A base rail is mandatory on unit sizes 025 to 065 and adds a minimum of 6" (152 mm) to the unit height. Unit sizes greater than 080 require a base rail that adds a minimum of 8" (203 mm) to the unit height.

### Side Load Cartridge and Bag Filter Section

Cartridge filter section

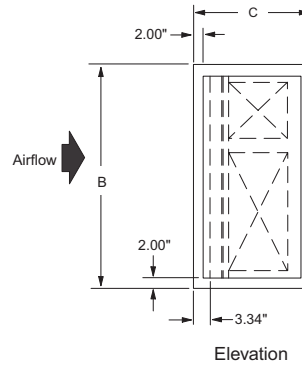
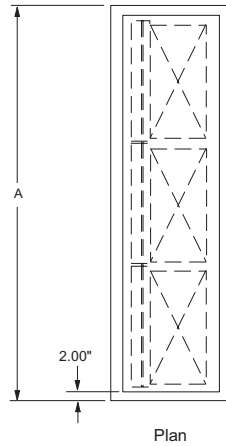

Bag filter section

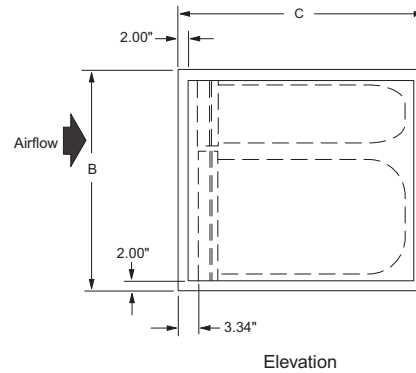
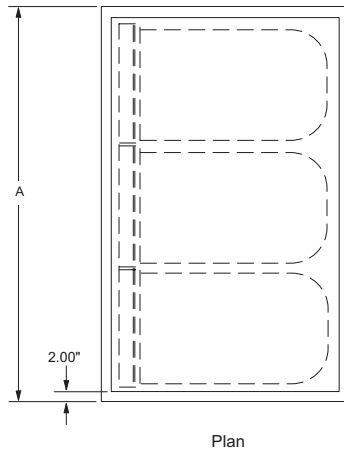

Table 43: Side Load Cartridge and Bag Filter Dimensions

Unit size	A* In. (mm)	B* In. (mm)
003	38.0 (965)	26.0 (660)
004	40.0 (1016)	30.0 (762)
006	52.0 (1321)	30.0 (762)
008	58.0 (1473)	34.0 (864)
010	64.0 (1626)	36.0 (914)
012	66.0 (1676)	42.0 (1067)
014	74.0 (1880)	42.0 (1067)
017	80.0 (2032)	46.0 (1168)
021	82.0 (2083)	52.0 (1321)
025	86.0 (2184)	60.0 (1524)
030	98.0 (2489)	60.0 (1524)
035	102.0 (2591)	66.0 (1676)
040	116.0 (2946)	68.0 (1727)
050	120.0 (3048)	80.0 (2032)
065	136.0 (3454)	92.0 (2337)
080	136.0 (3454)	98.0 (2489)
085	136.0 (3454)	104.0 (2642)
090	136.0 (3454)	110.0 (2794)

Table 44: Filter Dimensions

Filter type	C—all sizes, In. (mm)
<b>Cartridge</b>	
4" w/ 2" Pre	14.00 (356)
4" w/ 4" Pre	16.00 (406)
12" w/ 2" Pre	22.00 (559)
12" w/ 4" Pre	24.00 (610)
<b>Bag</b>	
12" w/ 2" Pre	18.00 (457)
12" w/ 4" Pre	20.00 (508)
15" w/ 2" Pre	22.00 (559)
15" w/ 4" Pre	24.00 (610)
19" w/ 2" Pre	26.00 (660)
19" w/ 4" Pre	28.00 (711)
22" w/ 2" Pre	28.00 (711)
22" w/ 4" Pre	30.00 (762)
30" w/ 2" Pre	36.00 (914)
30" w/ 4" Pre	38.00 (965)
36" w/ 2" Pre	42.00 (1067)
36" w/ 4" Pre	44.00 (1118)

\* Dimensions of unit only. A standard base rail adds 8" (203 mm) to the width, and between 4" to 12" (102 mm to 305 mm) to the unit height. A base rail is mandatory on unit sizes 025 and 065 and adds a minimum of 6" (152 mm) to the unit height. Unit sizes greater than 080 require a base rail that adds a minimum of 8" (203 mm) to the unit height.

### Front Load Cartridge and Bag Filter Section

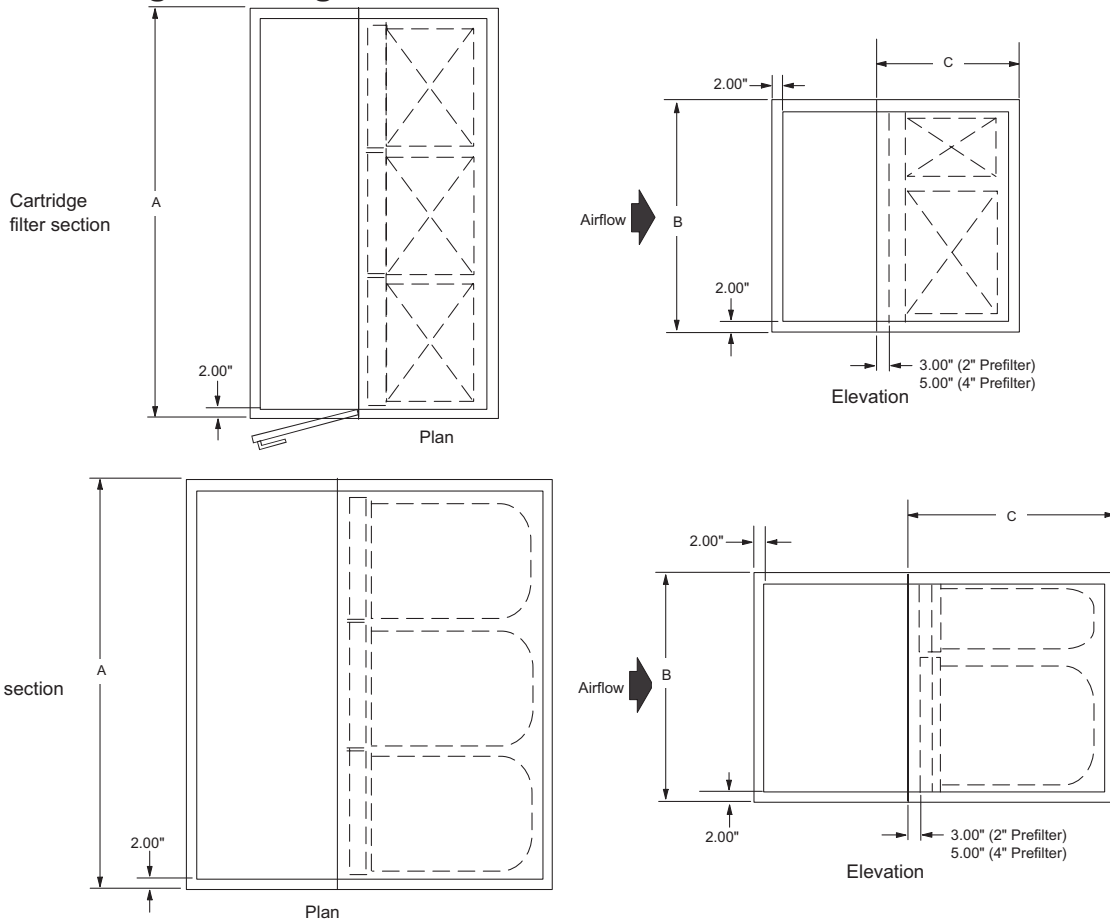

**Note:** An upstream plenum with tread plate is required on all front load filter sections.

**Table 45: Front Load Cartridge Bag Filter Section Dimensions**

Unit size	A*, In. (mm)	B*, In. (mm)
003	38.0 (965)	26.0 (660)
004	40.0 (1016)	30.0 (762)
006	52.0 (1321)	30.0 (762)
008	58.0 (1473)	34.0 (864)
010	64.0 (1626)	36.0 (914)
012	66.0 (1676)	42.0 (1067)
014	74.0 (1880)	42.0 (1067)
017	80.0 (2032)	46.0 (1168)
021	82.0 (2083)	52.0 (1321)
025	86.0 (2184)	60.0 (1524)
030	98.0 (2489)	60.0 (1524)
035	102.0 (2591)	66.0 (1676)
040	116.0 (2946)	68.0 (1727)
050	120.0 (3048)	80.0 (2032)
065	136.0 (3454)	92.0 (2337)
080	136.0 (3454)	98.0 (2489)
085	136.0 (3454)	104.0 (2642)
090	136.0 (3454)	110.0 (1795)

**Table 46: Filter Dimensions**

Filter type	C—all sizes
<b>Cartridge</b>	
4" w/ 2" Pre	12.0 (305)
4" w/ 4" Pre	12.0 (305)
12" w/ 2" Pre	16.0 (406)
12" w/ 4" Pre	16.0 (406)
<b>Bag</b>	
12" w/ 2" Pre	16.0 (406)
12" w/ 4" Pre	16.0 (406)
15" w/ 2" Pre	20.0 (508)
15" w/ 4" Pre	20.0 (508)
19" w/ 2" Pre	24.0 (610)
19" w/ 4" Pre	24.0 (610)
22" w/ 2" Pre	26.0 (660)
22" w/ 4" Pre	26.0 (660)
30" w/ 2" Pre	34.0 (864)
30" w/ 4" Pre	34.0 (864)
36" w/ 2" Pre	40.0 (1016)
36" w/ 4" Pre	40.0 (1016)

\* Dimensions of unit only. A standard base rail adds 8" (203 mm) to width and between 4" to 12" (102 mm to 305 mm) to unit height.

## Mixing Box and Combination Filter Mixing Box

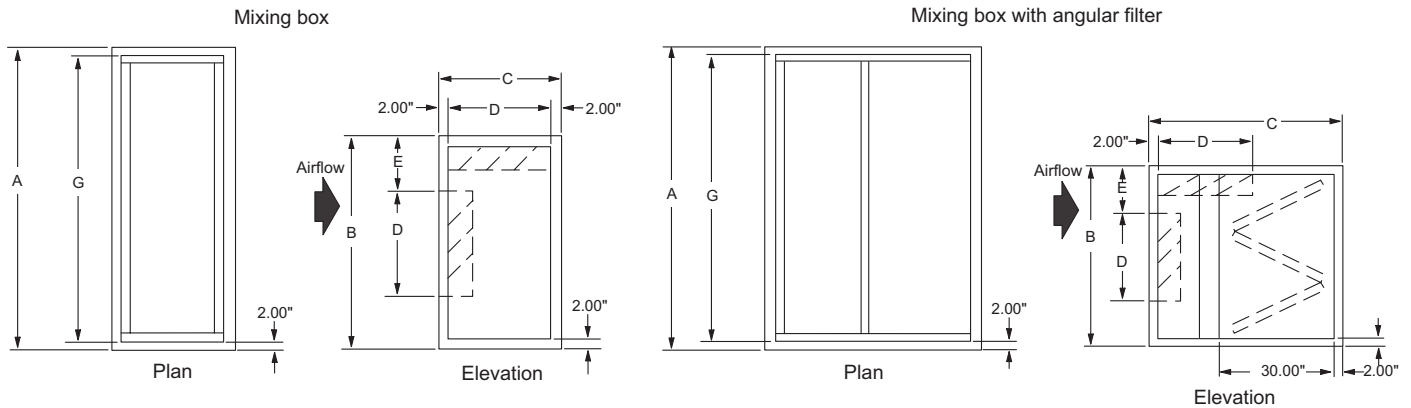

Note: Dampers can be located in the top, bottom, side, opposite drive side, and end of the section.

Table 47: Mixing Box and Combination Filter Mixing Box Dimensions

Unit size	A* In. (mm)	B* In. (mm)	C					D	E	G	Damper width	Damper length
			Mixing box only	w/ 2" flat filter	w/ 4" flat filter	w/ 2" an filter	w/ 4" an filter					
003	38 (965)	26 (660)	20 (508)	24 (610)	26 (660)	42 (1067)	N/A	16 (406)	8 (203)	34 (864)	12 (305)	24 (610)
004	40 (1016)	30 (762)	20 (508)	24 (610)	26 (660)	42 (1067)	N/A	16 (406)	12 (305)	36 (914)	12 (305)	26 (660)
006	52 (1321)	30 (762)	20 (508)	24 (610)	26 (660)	42 (1067)	N/A	16 (406)	12 (305)	48 (1219)	12 (305)	38 (965)
008	58 (1473)	34 (864)	20 (508)	24 (610)	26 (660)	42 (1067)	46 (1168)	16 (406)	10 (254)	54 (1372)	12 (305)	44 (1118)
010	64 (1626)	36 (914)	22 (559)	26 (660)	28 (711)	44 (1118)	48 (1219)	18 (457)	10 (254)	60 (1524)	14 (356)	50 (1270)
012	66 (1676)	42 (1067)	24 (610)	28 (711)	30 (762)	46 (1168)	50 (1270)	20 (508)	12 (305)	62 (1575)	16 (406)	52 (1321)
014	74 (1880)	42 (1067)	24 (610)	28 (711)	30 (762)	46 (1168)	50 (1270)	20 (508)	12 (305)	70 (1778)	16 (406)	60 (1524)
017	80 (2032)	46 (1168)	26 (660)	30 (762)	32 (813)	48 (1219)	52 (1321)	22 (559)	12 (305)	76 (1930)	18 (457)	66 (1676)
021	82 (2083)	52 (1321)	30 (762)	34 (864)	36 (914)	52 (1321)	56 (1422)	26 (660)	14 (356)	78 (1981)	22 (559)	68 (1727)
025	86 (2184)	60 (1524)	32 (813)	36 (914)	38 (965)	54 (1372)	58 (1473)	28 (711)	16 (406)	82 (2083)	24 (610)	72 (1829)
030	98 (2489)	60 (1524)	32 (813)	36 (914)	38 (965)	54 (1372)	58 (1473)	28 (711)	16 (406)	94 (2388)	24 (610)	84 (2134)
035	102 (2591)	66 (1676)	36 (914)	40 (1016)	42 (1067)	58 (1473)	62 (1575)	32 (813)	18 (457)	98 (2489)	28 (711)	88 (2235)
040	116 (2946)	68 (1727)	36 (914)	40 (1016)	42 (1067)	58 (1473)	62 (1575)	32 (813)	18 (457)	112 (2845)	28 (711)	102 (2591)
050	120 (3048)	80 (2032)	40 (1016)	44 (1118)	46 (1168)	62 (1575)	66 (1676)	36 (914)	22 (559)	116 (2946)	32 (813)	106 (2692)
065	136 (3454)	92 (2337)	46 (1168)	50 (1270)	52 (1321)	68 (1727)	72 (1829)	42 (1067)	26 (660)	132 (3353)	38 (965)	122 (3099)
080	136 (3454)	98 (2489)	50 (1270)	54 (1372)	56 (1422)	72 (1829)	76 (1930)	46 (3454)	26 (660)	132 (3353)	42 (1067)	122 (3099)
085	136 (3454)	104 (2642)	54 (1372)	58 (1473)	60 (1524)	76 (1930)	80 (2032)	50 (3454)	27 (686)	132 (3353)	46 (1168)	122 (3099)
090	136 (3454)	110 (2794)	56 (1422)	60 (1524)	62 (1575)	78 (1981)	82 (2083)	52 (3454)	29 (737)	132 (3353)	48 (1219)	122 (3099)

\* Dimensions of unit only. A standard base rail adds 8" (203 mm) to width and adds between 4" to 12" (102 mm to 305 mm) to unit height. A base rail mandatory on unit sizes 025 to 065—adds a minimum of 6" (152 mm) to unit height. Unit sizes greater than 080 require a base rail, which adds a minimum of 8" (203mm) to unit height.



### Economizer Section

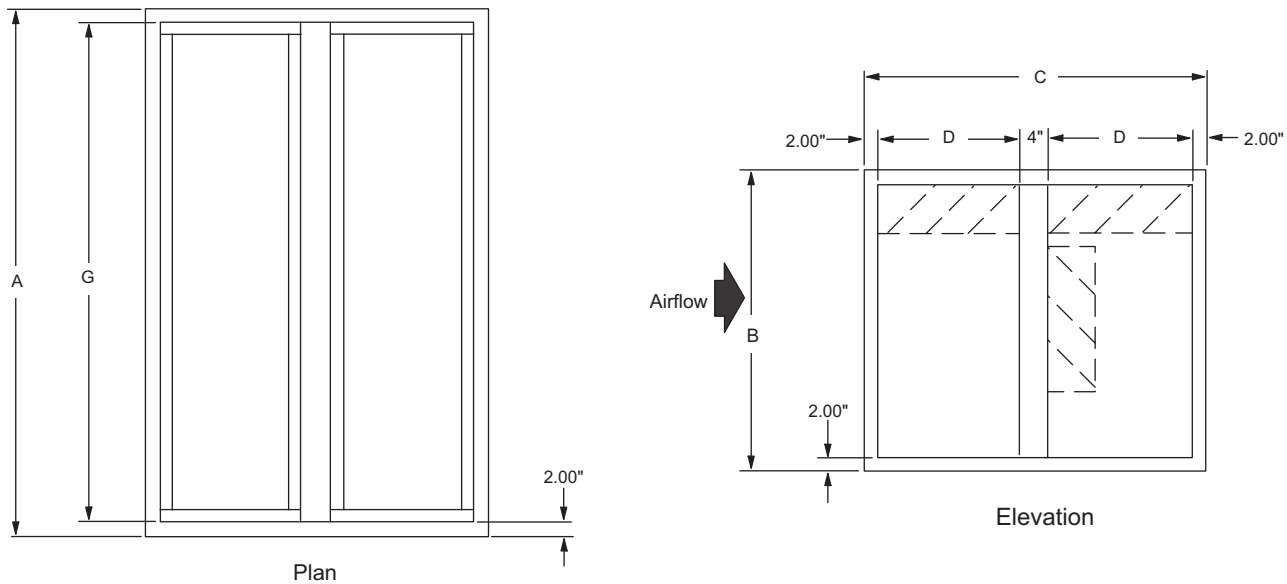

**Note:** Dampers can be located in the top, bottom, side, opposite drive side, and end of the section.

**Table 48: Economizer Dimensions**

Unit size	A* In. (mm)	B* In. (mm)	C				D	G	Damper width	Damper length	
			Econ. only	w/ 2" flat filter	w/ 4" flat filter	w/ 2" angle filter					w/ 4" angle filter
003	38 (965)	26 (660)	40 (1016)	44 (1118)	46 (1168)	62 (1575)	N/A	16 (406)	34 (864)	12 (305)	24 (610)
004	40 (1016)	30 (762)	40 (1016)	44 (1118)	46 (1168)	62 (1575)	N/A	16 (406)	36 (914)	12 (305)	26 (660)
006	52 (1321)	30 (762)	40 (1016)	44 (1118)	46 (1168)	62 (1575)	N/A	16 (406)	48 (1219)	12 (305)	38 (965)
008	58 (1473)	34 (864)	40 (1016)	44 (1118)	46 (1168)	62 (1575)	66 (1676)	16 (406)	54 (1372)	12 (305)	44 (1118)
010	64 (1626)	36 (914)	44 (1118)	48 (1219)	50 (1270)	66 (1676)	70 (1778)	18 (457)	60 (1524)	14 (356)	50 (1270)
012	66 (1676)	42 (1067)	48 (1219)	52 (1321)	54 (1372)	70 (1778)	74 (1880)	20 (508)	62 (1575)	16 (406)	52 (1321)
014	74 (1880)	42 (1067)	48 (1219)	52 (1321)	54 (1372)	70 (1778)	74 (1880)	20 (508)	70 (1778)	16 (406)	60 (1524)
017	80 (2032)	46 (1168)	52 (1321)	56 (1422)	58 (1473)	74 (1880)	78 (1981)	22 (559)	76 (1930)	18 (457)	66 (1676)
021	82 (2083)	52 (1321)	60 (1524)	64 (1626)	66 (1676)	82 (2083)	86 (2184)	26 (660)	78 (1981)	22 (559)	68 (1727)
025	86 (2184)	60 (1524)	64 (1626)	68 (1727)	70 (1778)	86 (2184)	90 (2286)	28 (711)	82 (2083)	24 (610)	72 (1829)
030	98 (2489)	60 (1524)	64 (1626)	68 (1727)	70 (1778)	86 (2184)	90 (2286)	28 (711)	94 (2388)	24 (610)	84 (2134)
035	102 (2591)	66 (1676)	72 (1829)	76 (1930)	78 (1981)	94 (2388)	98 (2489)	32 (813)	98 (2489)	28 (711)	88 (2235)
040	116 (2946)	68 (1727)	72 (1829)	76 (1930)	78 (1981)	94 (2388)	98 (2489)	32 (813)	112 (2845)	28 (711)	102 (2591)
050	120 (3048)	80 (2032)	80 (2032)	84 (2134)	86 (2184)	102 (2591)	106 (2692)	36 (914)	116 (2946)	32 (813)	106 (2692)
065	136 (3454)	92 (2337)	92 (2337)	96 (2438)	98 (2489)	114 (2896)	118 (2997)	42 (1067)	132 (3353)	38 (965)	122 (3099)
080	136 (3454)	98 (3489)	100 (2540)	108 (2743)	112 (2845)	144 (3658)	152 (3861)	46 (1168)	132 (3353)	42 (1067)	122 (3099)
085	136 (3454)	104 (2642)	108 (2743)	116 (2946)	120 (3048)	152 (3861)	160 (4064)	50 (1270)	132 (3353)	46 (1168)	122 (3099)
090	136 (3454)	110 (2794)	112 (2845)	120 (3048)	124 (3150)	156 (3962)	164 (4166)	52 (1321)	132 (3353)	48 (1219)	122 (3099)

\* These are the dimensions of the unit only. Curb-ready base adds 6" (152 mm) to the unit height. A standard base rail adds 8" (203 mm) to the width, and between 4" to 12" (102 mm to 305 mm) to the unit height. A base rail—mandatory on unit sizes 025 to 065—adds a minimum of 6" (152 mm) to the unit height. Unit sizes greater than 080 require a base rail that adds a minimum of 8" (203 mm) to the unit height.

# Angled Economizer Section

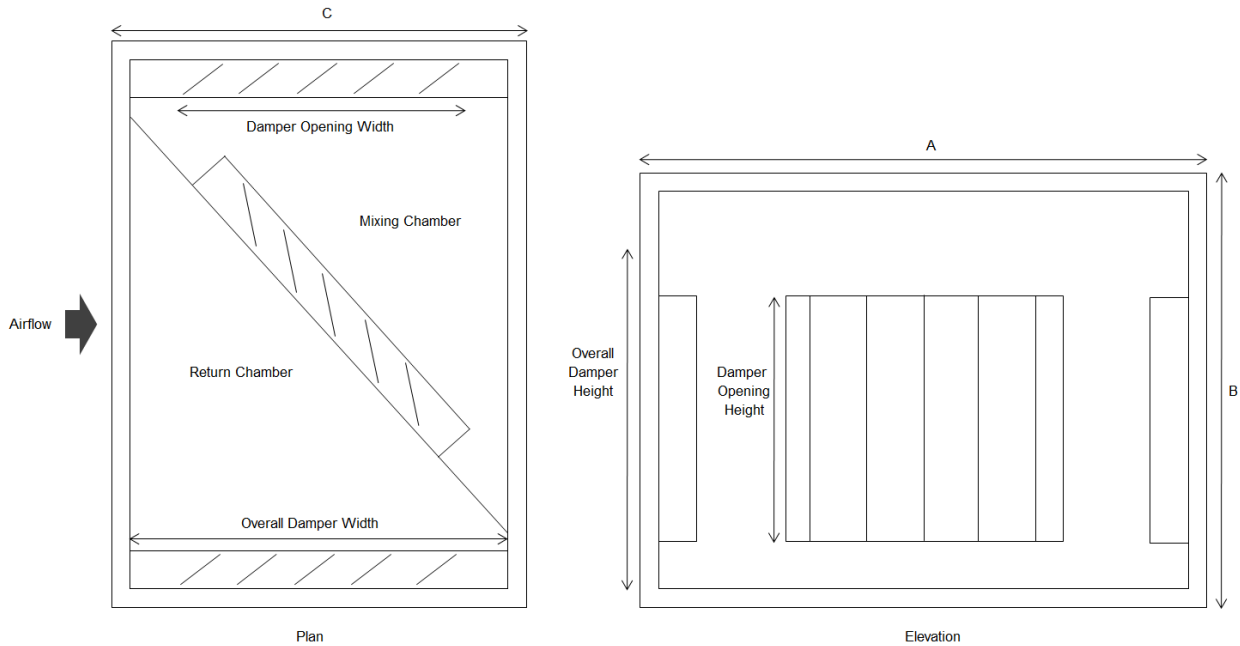
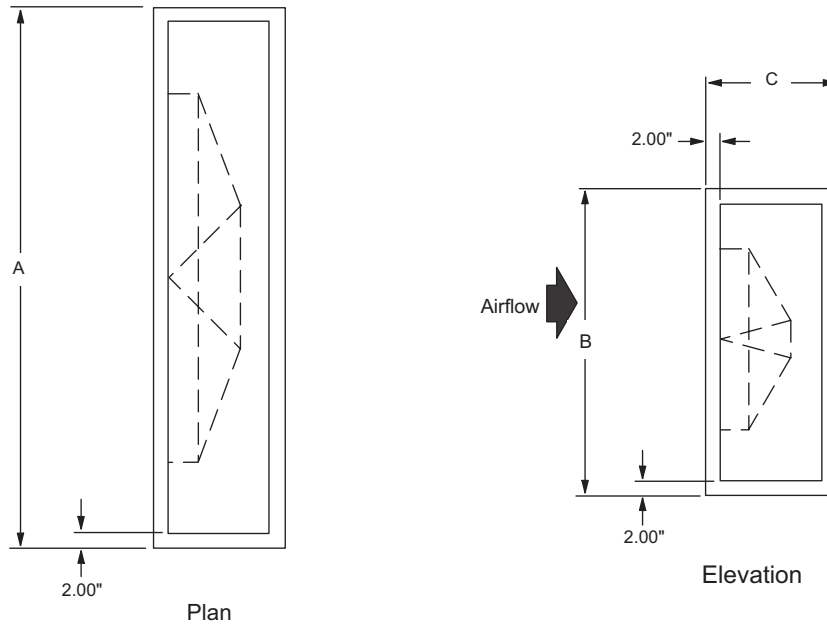

**Table 49: Angled Economizer Section**

Unit Size	A*	B*	C	Overall Damper		Damper Opening	
				Width	Height	Width	Height
	in. (mm)	in. (mm)	in. (mm)	in. (mm)	in. (mm)	in. (mm)	in. (mm)
003	38 (965)	26 (660)	24 (610)	16 (406)	22 (559)	12 (305)	12 (305)
004	40 (1016)	30 (762)	24 (610)	16 (406)	26 (660)	12 (305)	16 (406)
006	52 (1321)	30 (762)	26 (660)	22 (559)	26 (660)	18 (457)	16 (406)
008	58 (1473)	34 (864)	36 (914)	32 (813)	24 (610)	28 (711)	14 (356)
010	64 (1626)	36 (914)	38 (965)	34 (864)	26 (660)	30 (762)	16 (406)
012	66 (1676)	42 (1067)	36 (914)	32 (813)	32 (813)	28 (711)	22 (559)
014	74 (1880)	42 (1067)	40 (1016)	36 (914)	32 (813)	32 (813)	22 (559)
017	80 (2032)	46 (1168)	40 (1016)	36 (914)	36 (914)	32 (813)	26 (660)
021	82 (2083)	52 (1321)	40 (1016)	36 (914)	42 (1067)	32 (813)	32 (813)
025	86 (2184)	60 (1524)	38 (965)	34 (864)	50 (1270)	30 (762)	40 (1016)
030	98 (2489)	60 (1524)	44 (1118)	40 (1016)	50 (1270)	36 (914)	40 (1016)
035	102 (2591)	66 (1676)	46 (1168)	42 (1067)	56 (1422)	38 (965)	46 (1168)
040	116 (2946)	68 (1727)	48 (1219)	44 (1118)	58 (1473)	40 (1016)	48 (1219)
050	120 (3048)	80 (2032)	48 (1219)	44 (1118)	70 (1778)	40 (1016)	60 (1524)
065	136 (3454)	92 (2337)	52 (1321)	48 (1219)	82 (2083)	44 (1118)	72 (1829)
080	136 (3454)	98 (2489)	68 (1727)	60 (1524)	88 (2235)	52 (1321)	78 (1981)
085	136 (3454)	104 (2642)	68 (1727)	60 (1524)	94 (2388)	52 (1321)	84 (2134)
090	136 (3454)	110 (2794)	56 (1422)	52 (1321)	100 (2540)	48 (1219)	90 (2286)

\* These are the dimensions of the unit only. Curb-ready base adds 6" (152 mm) to the unit height. A standard base rail adds 8" (203 mm) to the width, and between 4" to 12" (102 mm to 305 mm) to the unit height. A base rail—mandatory on unit sizes 025 to 065—adds a minimum of 6" (152 mm) to the unit height. Unit sizes greater than 080 require a base rail that adds a minimum of 8" (203 mm) to the unit height.

# Blenders



**Note:** The depth of an air mixer section varies depending on components adjacent to the mixing device. The catalog dimensions shown are for a two-blender system except sizes 040 to 090, which are three-blender systems. For applications other than this, the depth dimension varies. Use Vision Select Tools software for more detailed dimensional information.

**Table 50: Blender Product Series IV Dimensions**

Unit size	A* In. (mm)	B* In. (mm)	C In. (mm)
003	38.0 (965)	26.0 (660)	N/A
004	40.0 (1016)	30.0 (762)	12.0 (305)
006	52.0 (1321)	30.0 (762)	14.0 (356)
008	58.0 (1473)	34.0 (864)	16.0 (406)
010	64.0 (1626)	36.0 (914)	18.0 (457)
012	66.0 (1676)	42.0 (1067)	20.0 (508)
014	74.0 (1880)	42.0 (1067)	22.0 (559)
017	80.0 (2032)	46.0 (1168)	24.0 (610)
021	82.0 (2083)	52.0 (1321)	28.0 (711)
025	86.0 (2184)	60.0 (1524)	32.0 (813)
030	98.0 (2489)	60.0 (1524)	34.0 (864)
035	102.0 (2591)	66.0 (1676)	36.0 (914)
040	116.0 (2946)	68.0 (1727)	38.0 (965)
050	120.0 (3048)	80.0 (2032)	46.0 (1168)
065	136.0 (3454)	92.0 (2337)	52.0 (1321)
080	136.0 (3454)	98.0 (3489)	54.0 (1372)
085	136.0 (3454)	104.0 (2642)	56.0 (1422)
090	136.0 (3454)	110.0 (2794)	58.0 (1473)

**Table 51: Kees Blender Dimensions**

Unit size	A** In. (mm)	B* In. (mm)	C In. (mm)
003	38.0 (965)	26.0 (660)	N/A
004	40.0 (1016)	30.0 (762)	N/A
006	52.0 (1321)	30.0 (762)	22.0 (559)
008	58.0 (1473)	34.0 (864)	24.0 (610)
010	64.0 (1626)	36.0 (914)	26.0 (660)
012	66.0 (1676)	42.0 (1067)	28.0 (711)
014	74.0 (1880)	42.0 (1067)	30.0 (762)
017	80.0 (2032)	46.0 (1168)	32.0 (813)
021	82.0 (2083)	52.0 (1321)	36.0 (914)
025	86.0 (2184)	60.0 (1524)	38.0 (965)
030	98.0 (2489)	60.0 (1524)	40.0 (1016)
035	102.0 (2591)	66.0 (1676)	42.0 (1067)
040	116.0 (2946)	68.0 (1727)	38.0 (965)
050	120.0 (3048)	80.0 (2032)	42.0 (1067)
065	136.0 (3454)	92.0 (2337)	46.0 (1168)
080	136.0 (3454)	98.0 (3489)	56.0 (1422)
085	136.0 (3454)	104.0 (2642)	58.0 (1473)
090	136.0 (3454)	110.0 (2794)	58.0 (1473)

\* These are the dimensions of the unit only. A standard base rail adds 8" (203 mm) to the width, and between 4" to 12" (102 mm to 305 mm) to the unit height.

\*\* All values represent Kees blenders located after filters.

A 6" (152 mm) base rail is mandatory on unit sizes 025 to 065. An 8" (203 mm) base rail is mandatory on all sizes 080 and larger.

## Access Doors

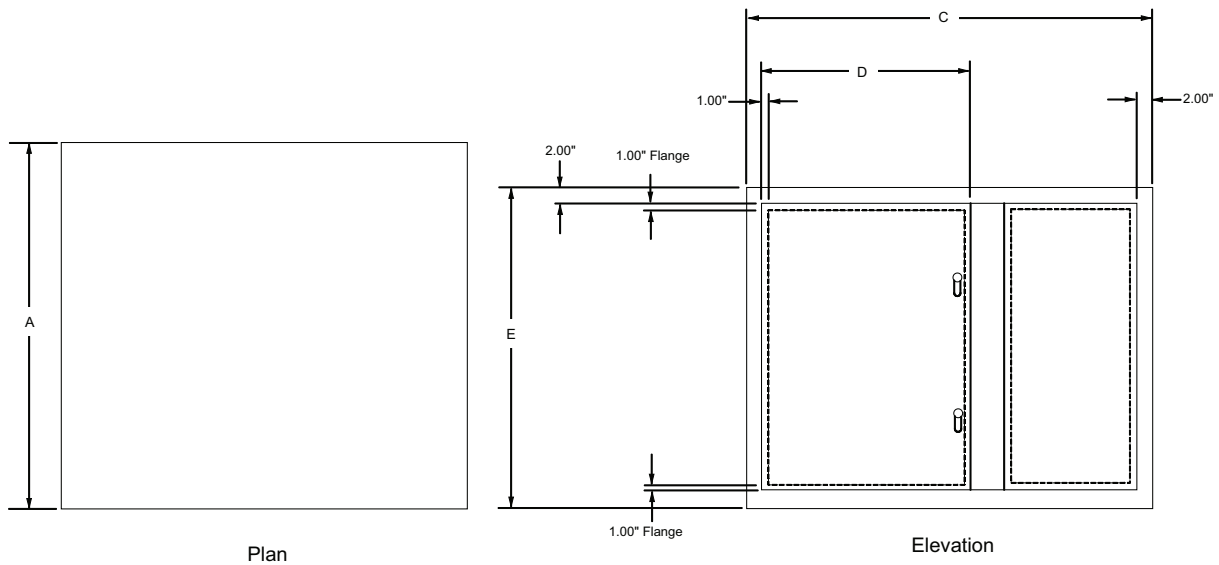

Access doors are an option for most sections. Fan sections are always provided with a door on one side of the unit. Access door size varies with the size of the section; they are never wider than 30". On most components doors can be selected as inward opening. Once the door is opened outward, the opening is 2" less than the door height and width because there is a 1" flange around the opening. Once the door is opened inward,

the opening is 3" less than the door height and width since there is no flange around the opening. Door height is always 4" shorter than section height unless the section has a drain connection. If the section has a drain pan, then the door is 6" shorter than the section height. The maximum door height is 64", except filter section doors, which are equal to section height minus 4".

**Table 52: Access Door Dimensions**

Unit cross section			
Unit size	A, In. (mm)	B*, In. (mm)	E, In. (mm)
003	38.0 (965)	26.0 (660)	20 (508)
004	40.0 (1016)	30.0 (762)	24 (609.6)
006	52.0 (1321)	30.0 (762)	24 (609.6)
008	58.0 (1473)	34.0 (864)	28 (711.2)
010	64.0 (1626)	36.0 (914)	30 (762)
012	66.0 (1676)	42.0 (1067)	36 (914.4)
014	74.0 (1880)	42.0 (1067)	36 (914.4)
017	80.0 (2032)	46.0 (1168)	38 (965.2)
021	82.0 (2083)	52.0 (1321)	46 (1168.4)
025	86.0 (2184)	60.0 (1524)	54 (1371.6)
030	98.0 (2489)	60.0 (1524)	54 (1371.6)
035	102.0 (2591)	66.0 (1676)	60 (1524)
040	116.0 (2946)	68.0 (1727)	62 (1574.8)
050	120.0 (3048)	80.0 (2032)	68 (1727.2)
065	136.0 (3454)	92.0 (2337)	68 (1727.2)
080	136.0 (3454)	98.0 (3489)	68 (1727.2)
085	136.0 (3454)	104.0 (2642)	68 (1727.2)
090	136.0 (3454)	110.0 (2794)	68 (1727.2)

**Table 53: Door Widths**

Available door widths based on section length	
C, In. (mm)	D, In. (mm)
12.0 (305)	8.0 (203)
14.0 (356)	10.0 (254)
16.0 (406)	12.0 (305)
18.0 (457)	14.0 (356)
20.0 (508)	16.0 (406)
22.0 (559)	18.0 (457)
24.0 (610)	20.0 (508)
26.0 (660)	22.0 (559)
28.0 (711)	24.0 (610)
30.0 (762)	26.0 (660)
32.0 (813)	28.0 (711)
34.0 (864)	30.0 (762)
36.0 (914)	28.0 (711)
38.0 (965)	30.0 (762)
40.0 (1016)	30.0 (762)
42.0 (1067)	30.0 (762)
44.0 (1118)	30.0 (762)
46.0 (1168)	30.0 (762)
48.0 (1219)	30.0 (762)
50.0 (1270)	30.0 (762)
52.0 (1321)	30.0 (762)
54.0 (1372)	30.0 (762)

\* Filter access doors are the "B" dimension minus 6".

A standard base rail adds 8" (203 mm) to width and between 4" to 12" (102 mm to 305 mm) to unit height.

A 6" (152 mm) base rail is mandatory on unit sizes 025 to 065.

An 8" (203 mm) base rail is mandatory on all sizes 080 and larger.

# Diffuser

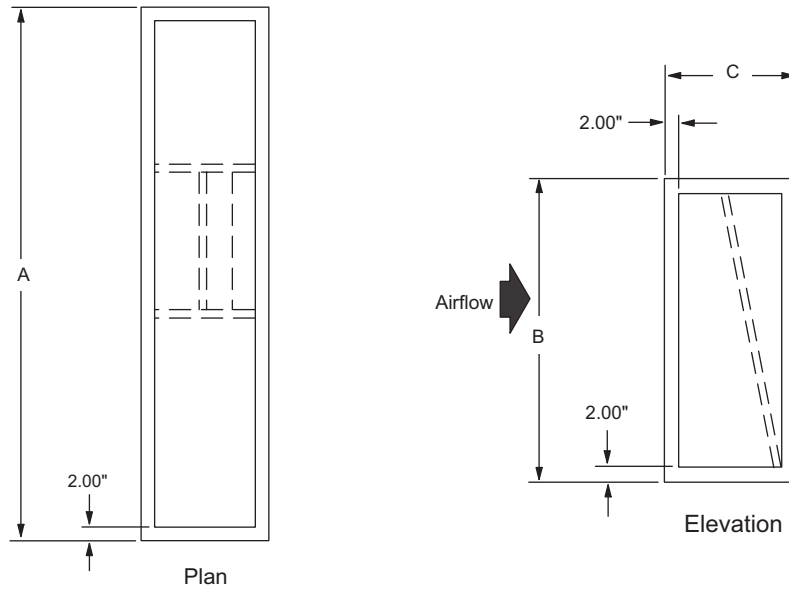
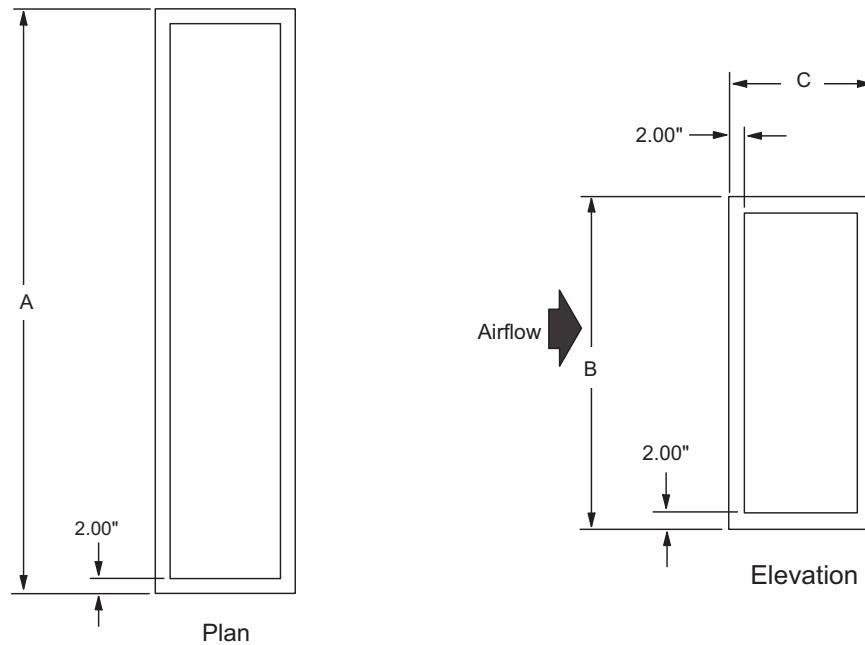

Table 54: Diffuser Dimensions

Unit	A* In. (mm)	B* In. (mm)	C, In. (mm)	
			Housed fans	Inline fans
003	38.0 (965)	26.0 (660)	10.0 (254)	N/A
004	40.0 (1016)	30.0 (762)	10.0 (254)	N/A
006	52.0 (1321)	30.0 (762)	10.0 (254)	N/A
008	58.0 (1473)	34.0 (864)	12.0 (305)	N/A
010	64.0 (1626)	36.0 (914)	12.0 (305)	18.0 (457)
012	66.0 (1676)	42.0 (1067)	16.0 (406)	18.0 (457)
014	74.0 (1880)	42.0 (1067)	16.0 (406)	18.0 (457)
017	80.0 (2032)	46.0 (1168)	16.0 (406)	22.0 (559)
021	82.0 (2083)	52.0 (1321)	16.0 (406)	26.0 (660)
025	86.0 (2184)	60.0 (1524)	24.0 (610)	26.0 (660)
030	98.0 (2489)	60.0 (1524)	24.0 (610)	26.0 (660)
035	102.0 (2591)	66.0 (1676)	24.0 (610)	28.0 (711)
040	116.0 (2946)	68.0 (1727)	30.0 (762)	30.0 (762)
050	120.0 (3048)	80.0 (2032)	30.0 (762)	36.0 (914)
065	136.0 (3454)	92.0 (2337)	30.0 (762)	38.0 (965)
080	136.0 (3454)	98.0 (3489)	30.0 (762)	38.0 (965)
085	136.0 (3454)	104.0 (2642)	30.0 (762)	38.0 (965)
090	136.0 (3454)	110.0 (2794)	30.0 (762)	38.0 (965)

\* These are the dimensions of the unit only. A standard base rail adds 8" (203 mm) to the width, and between 4" to 12" (102 mm to 305 mm) to the unit height. A 6" (152 mm) base rail is mandatory on unit sizes 025 to 065. An 8" (203 mm) base rail is mandatory on all sizes 080 and larger.

### Access Section



Note: 1.25 MPT drain connection available as an option for access sections.

Table 55: Access Section Dimensions

Unit size	A* In. (mm)	B* In. (mm)	C** (available all sizes) In. (mm)
003	38.0 (965)	26.0 (660)	16.0 (457) to 54.0 (1372) In 2" increments
004	40.0 (1016)	30.0 (762)	
006	52.0 (1321)	30.0 (762)	
008	58.0 (1473)	34.0 (864)	
010	64.0 (1626)	36.0 (914)	
012	66.0 (1676)	42.0 (1067)	
014	74.0 (1880)	42.0 (1067)	
017	80.0 (2032)	46.0 (1168)	
021	82.0 (2083)	52.0 (1321)	
025	86.0 (2184)	60.0 (1524)	
030	98.0 (2489)	60.0 (1524)	
035	102.0 (2591)	66.0 (1676)	
040	116.0 (2946)	68.0 (1727)	
050	120.0 (3048)	80.0 (2032)	
065	136.0 (3454)	92.0 (2337)	
080	136.0 (3454)	98.0 (3489)	
085	136.0 (3454)	104.0 (2642)	
090	136.0 (3454)	110.0 (2794)	

\* These are the dimensions of the unit only. A standard base rail adds 8" (203 mm) to the width, and between 4" to 12" (102 mm to 305 mm) to the unit height. A 6" (152 mm) base rail is mandatory on unit sizes 025 to 065. An 8" (203 mm) base rail is mandatory on all sizes 080 and larger.

# Internal/External Face and Bypass Sections

Internal face and bypass with small and medium face area coil

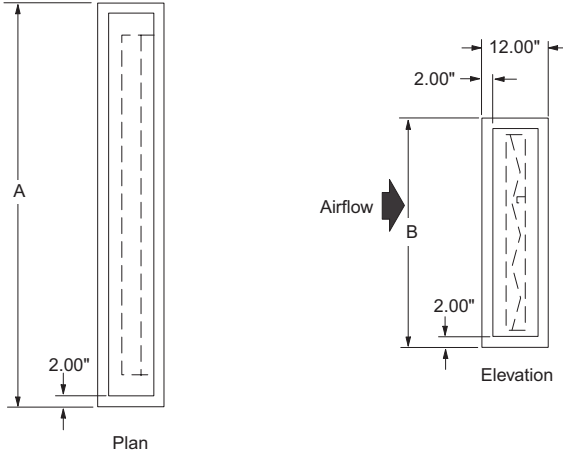

External face and bypass with large face area coil

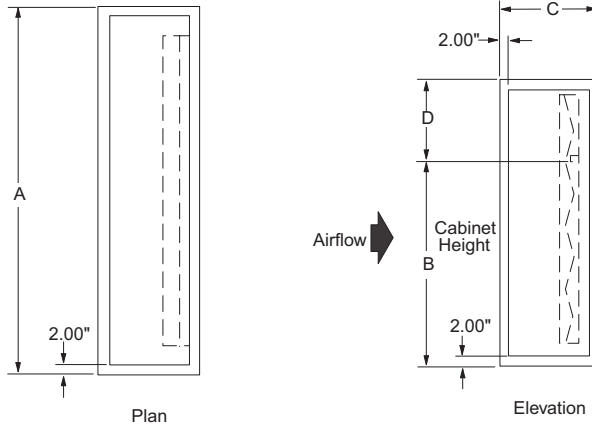

**Table 56: Internal and External Faced and Bypass Dimensions**

Unit size	A* In. (mm)	B* In. (mm)	C, In. (mm)		D In. (mm)
			Internal	External	
003	38.0 (965)	26.0 (660)	12.0 (305)	18.0 (457)	10.0 (254)
004	40.0 (1016)	30.0 (762)	12.0 (305)	18.0 (457)	10.0 (254)
006	52.0 (1321)	30.0 (762)	12.0 (305)	18.0 (457)	10.0 (254)
008	58.0 (1473)	34.0 (864)	12.0 (305)	20.0 (508)	10.0 (254)
010	64.0 (1626)	36.0 (914)	12.0 (305)	22.0 (559)	12.0 (305)
012	66.0 (1676)	42.0 (1067)	12.0 (305)	24.0 (610)	16.0 (406)
014	74.0 (1880)	42.0 (1067)	12.0 (305)	24.0 (610)	16.0 (406)
017	80.0 (2032)	46.0 (1168)	12.0 (305)	26.0 (660)	16.0 (406)
021	82.0 (2083)	52.0 (1321)	12.0 (305)	30.0 (762)	22.0 (559)
025	86.0 (2184)	60.0 (1524)	12.0 (305)	32.0 (813)	24.0 (610)
030	98.0 (2489)	60.0 (1524)	12.0 (305)	32.0 (813)	24.0 (610)
035	102.0 (2591)	66.0 (1676)	12.0 (305)	34.0 (864)	26.0 (660)
040**	116.0 (2946)	68.0 (1727)	12.0 (305)	38.0 (965)	26.0 (660)
050**	120.0 (3048)	80.0 (2032)	12.0 (305)	44.0 (1118)	32.0 (813)
065**	136.0 (3454)	92.0 (2337)	12.0 (305)	50.0 (1270)	36.0 (914)
080**	136.0 (3454)	98.0 (3489)	12.0 (305)	54.0 (1372)	38.0 (965)
085**	136.0 (3454)	104.0 (2642)	12.0 (305)	56.0 (1422)	42.0 (1067)
090**	136.0 (3454)	110.0 (2794)	12.0 (305)	58.0 (1473)	42.0 (1067)

\* These are the dimensions of the unit only. A standard base rail adds 8" (203 mm) to the width, and between 4" to 12" (102 mm to 305 mm) to the unit height.  
 A 6" (152 mm) base rail is mandatory on unit sizes 025-065. An 8" (203 mm) base rail is mandatory on all sizes 080 and larger.  
 \*\* Right angle face and bypass dampers are mandatory on unit sizes 040 and larger.



## Discharge or Return Plenum

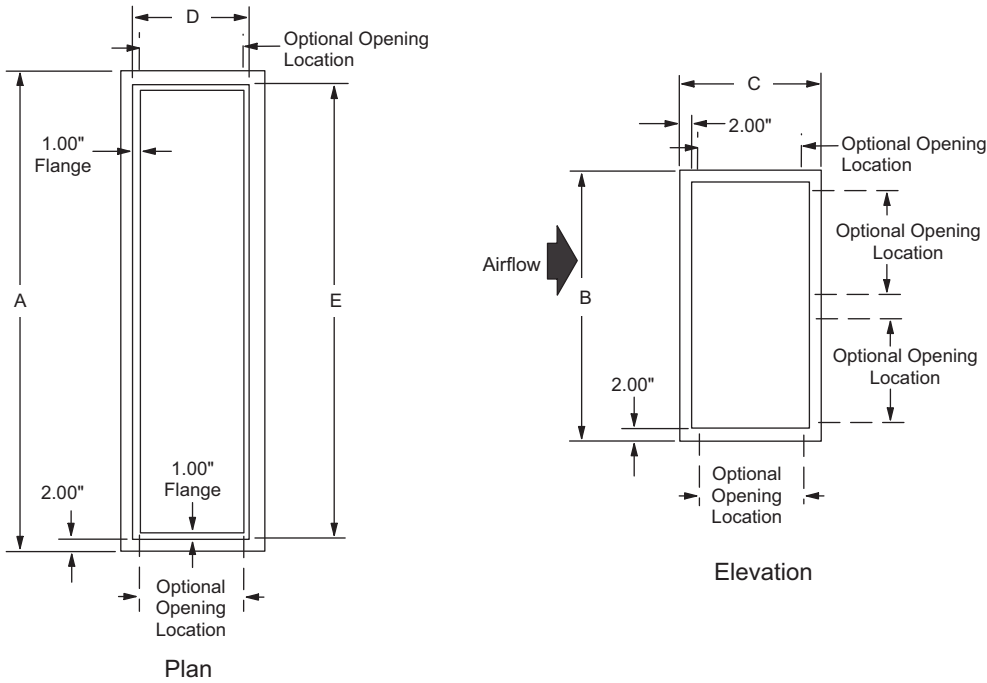

Return and discharge plenums are available with openings in the top, bottom, upper end, lower end, drive side, or opposite drive side. The opening size does not vary with the location. All openings have a 1" flange recessed in opening. 1.25 MPT drain connection available as an option for plenum sections

**Table 57: Discharge or Return Plenum Dimensions**

Unit size	A* In. (mm)	B* In. (mm)	C In. (mm)	D In. (mm)	E In. (mm)
003	38.0 (965)	26.0 (660)	14.0 (356)	10.0 (254)	34.0 (864)
004	40.0 (1016)	30.0 (762)	16.0 (406)	12.0 (305)	36.0 (914)
006	52.0 (1321)	30.0 (762)	16.0 (406)	12.0 (305)	48.0 (1219)
008	58.0 (1473)	34.0 (864)	18.0 (457)	14.0 (356)	54.0 (1372)
010	64.0 (1626)	36.0 (914)	20.0 (508)	16.0 (406)	60.0 (1524)
012	66.0 (1676)	42.0 (1067)	22.0 (559)	18.0 (457)	62.0 (1575)
014	74.0 (1880)	42.0 (1067)	22.0 (559)	18.0 (457)	70.0 (1778)
017	80.0 (2032)	46.0 (1168)	24.0 (610)	20.0 (508)	76.0 (1930)
021	82.0 (2083)	52.0 (1321)	28.0 (711)	24.0 (610)	78.0 (1981)
025	86.0 (2184)	60.0 (1524)	30.0 (762)	26.0 (660)	82.0 (2083)
030	98.0 (2489)	60.0 (1524)	30.0 (762)	26.0 (660)	94.0 (2388)
035	102.0 (2591)	66.0 (1676)	32.0 (813)	28.0 (711)	98.0 (2489)
040	116.0 (2946)	68.0 (1727)	32.0 (813)	28.0 (711)	112.0 (2845)
050	120.0 (3048)	80.0 (2032)	38.0 (965)	34.0 (864)	116.0 (2946)
065	136.0 (3454)	92.0 (2337)	42.0 (1067)	38.0 (965)	132.0 (3353)
080	136.0 (3454)	98.0 (3489)	42.0 (1067)	44.0 (1118)	132.0 (3353)
085	136.0 (3454)	104.0 (2642)	44.0 (1118)	48.0 (1219)	132.0 (3353)
090	136.0 (3454)	110.0 (2794)	46.0 (1168)	50.0 (1270)	132.0 (3353)

\* These are the dimensions of the unit only. A standard base rail adds 8" (203 mm) to the width, and between 4" to 12" (102 mm to 305 mm) to the unit height. A 6" (152 mm) base rail is mandatory on unit sizes 025 to 065. An 8" (203 mm) base rail is mandatory on all sizes 080 and larger.

### Sound Attenuator Section

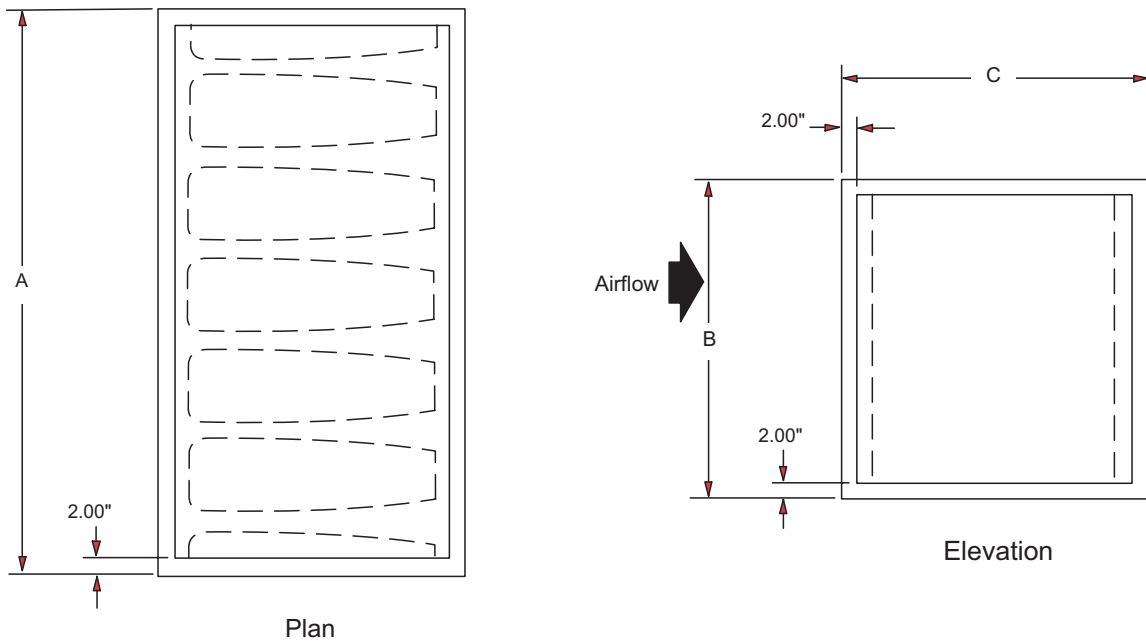

Table 58: Sound Attenuator Dimensions

Unit size	A* In. (mm)	B* In. (mm)	C** (available all sizes) In. (mm)
003	38.0 (965)	26.0 (660)	—
004	40.0 (1016)	30.0 (762)	40.0 (1016)
006	52.0 (1321)	30.0 (762)	52.0 (1321)
008	58.0 (1473)	34.0 (864)	64.0 (1626)
010	64.0 (1626)	36.0 (914)	—
012	66.0 (1676)	42.0 (1067)	—
014	74.0 (1880)	42.0 (1067)	—
017	80.0 (2032)	46.0 (1168)	—
021	82.0 (2083)	52.0 (1321)	—
025	86.0 (2184)	60.0 (1524)	—
030	98.0 (2489)	60.0 (1524)	—
035	102.0 (2591)	66.0 (1676)	—
040	116.0 (2946)	68.0 (1727)	—
050	120.0 (3048)	80.0 (2032)	—
065	136.0 (3454)	92.0 (2337)	—
080	136.0 (3454)	98.0 (3489)	—
085	136.0 (3454)	104.0 (2642)	—
090	136.0 (3454)	110.0 (2794)	—

\* These are the dimensions of the unit only. A standard base rail adds 8" (203 mm) to the width, and between 4" to 12" (102 mm to 305 mm) to the unit height. A 6" (152 mm) base rail is mandatory on unit sizes 025 to 065. An 8" (203 mm) base rail is mandatory on all sizes 080 and larger.

\*\* 40.00", 52.00" and 64.00" actuator section lengths available for all unit sizes.

# Base Rail

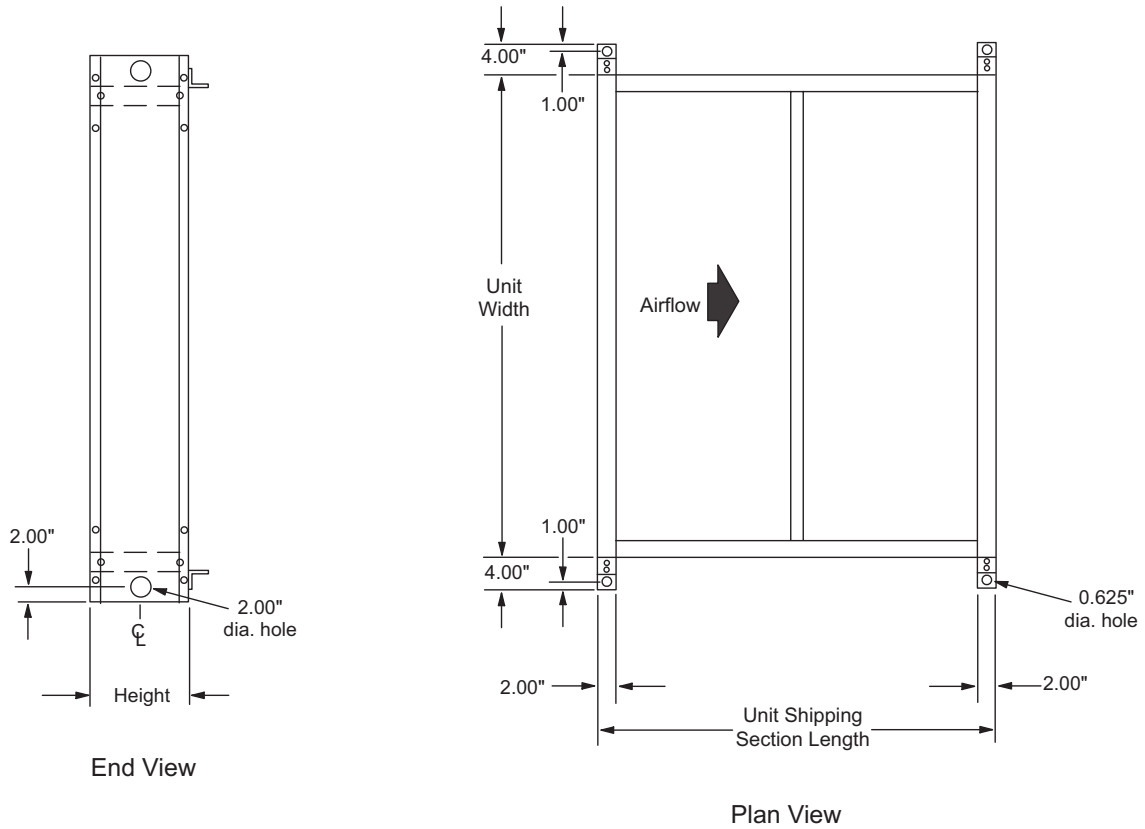

**Note:** The base rail is available in heights of 4", 6", 8", 10", and 12".

## Supply Power Wiring

1. Units required three phase power supply.
2. Allowable voltage tolerances:
  - a. 60 Hertz  
 Nameplate 208 V: Min. 187 V, max. 229 V  
 Nameplate 230 V: Min. 207 V, max. 253 V  
 Nameplate 460 V: Min. 414 V, max. 506 V  
 Nameplate 575 V: Min. 518 V, max. 633 V
3. **Minimum Circuit Ampacity (MCA) calculation:**

**Note:** If a unit is provided with multiple power connections, each must be considered alone in selecting power wiring components.

For units with cooling and heating:

$$MCA = 1.25 \times \text{largest load} + \text{sum of all other loads}$$

**Note:** Control circuit ampacity does not need to be considered in the calculation for wire sizing ampacity. If the unit is provided with one or more fan section lights, they are powered from the separate 15 amp (minimum), 120 V supply required by the NEC for the unit convenience outlet.

4. Size wires in accordance with Table 310-16 or 310-19 of the [National Electrical Code](#).
5. Wires should be sized for a maximum of 3% voltage drop.

**Table 59: Recommended Power Wiring**

Ampacity	No. of power wires per Phase	Wire gauge	Insulation rating (0°C)
30	1	10	75
40	1	8	75
55	1	6	75
70	1	4	75
85	1	3	75
95	1	2	75
130	1	1	75
150	1	1/0	75
175	1	2/0	75
200	1	3/0	75
230	1	4/0	75
255	1	250	75
300	2	1/0	75
350	2	2/0	75
400	2	3/0	75
460	2	4/0	75
510	2	250	75
600	3	3/0	75
690	3	4/0	75
765	3	250	75

## PART 1: GENERAL

### 1.01 SECTION INCLUDES

- A. Indoor air handling units

### 1.02 REFERENCES

- A. AFBMA 9 - Load Ratings and Fatigue Life for Ball Bearings
- B. AMCA 99 - Standards Handbook
- C. AMCA 210 - Laboratory Methods of Testing Fans for Rating Purposes
- D. AMCA 300 - Test Code for Sound Rating Air Moving Devices
- E. AMCA 500 - Test Methods for Louver, Dampers, and Shutters
- F. AHRI 410 - Forced-Circulation Air-Cooling and Air-Heating Coils
- G. AHRI 430 - Central-Station Air-Handling Units
- H. AHRI 435 - Application of Central-Station Air-Handling Units
- I. ASTM B117 – Standard Practice for Operating Salt Spray Apparatus
- J. NEMA MG1 - Motors and Generators
- K. NFPA 70 - National Electrical Code
- L. SMACNA - HVAC Duct Construction Standards - Metal and Flexible
- M. UL 723 – Test for Surface Burning Characteristics of Building Materials
- N. UL 900 - Test Performance of Air Filter Units.
- O. UL 1995 – Standard for Heating and Cooling Equipment
- P. UL 94 – Test for Flammability of Plastic Materials for Parts in Devices and Appliances
- Q. IBC 2000, 2003 – International Building Code
- R. NFPA 90A – Standard for the Installation of Air Conditioning and Ventilating Systems
- S. NFPA 5000 – Building Construction and Safety Code T
- T. ASHRAE 90.1 Energy Code
- U. AHRI Standard 1060 – Rating Air-to-Air Heat Exchangers for Energy Recovery Ventilation Equipment
- V. GSA 2003 Facilities Standard - 5.9 HVAC Systems and Components

### 1.03 SUBMITTALS

- A. Shop Drawings: Indicate assembly, unit dimensions, weight loading, required clearances, construction details, field connection details, and electrical characteristics and connection requirements. Computer generated fan curves for each air handling unit shall be submitted with specific design operating point noted. A computer generated psychometric chart shall be submitted for each cooling coil with design points and final operating point clearly noted. Sound data for discharge, radiated and return positions shall be submitted by octave band for each unit. Calculations for required baserail heights to satisfy condensate trapping requirements of cooling coil shall be included.
- B. Product Data:
  1. Provide literature that indicates dimensions, weights, capacities, ratings, fan performance, and electrical characteristics and connection requirements.
  2. Provide data of filter media, filter performance data, filter assembly, and filter frames.
- C. Manufacturer's Installation Instructions.

### 1.04 QUALIFICATIONS

- A. Manufacturers specializing in manufacturing Air Handling Units specified in this section must prove minimum five years documented experience and issue a complete catalog on total product.

### 1.05 SAFETY AGENCY LISTED & CERTIFICATION

- A. Air handling units shall be cETLus safety listed that conforms to UL Standard 1995 and CAN/CSA Standard C22.2 No. 236. Units shall be accepted for use in New York City by the Department of Building, MEA 342-99-E.
- B. Air handler furnished with double width, double inlet (DWDI) and/or plenum fans shall be certified in accordance with the central station air handling units certification program, which is based on AHRI 430. (NOTE: Above does not apply to fan array)
- C. Air handling unit water heating & cooling coils shall be certified in accordance with the forced circulation air cooling and air heating coils certification program, which is based on AHRI Standard 410.

### 1.06 DELIVERY, STORAGE, AND HANDLING

- A. Deliver, store, protect and handle products to site.
- B. Accept products on site in factory-fabricated protective containers, with factory-installed shipping skids. Inspect for damage.
- C. Store in clean dry place and protect from weather and construction traffic. Handle carefully to avoid damage to components, enclosures, and finish.

**PART 2: PRODUCTS**

**2.01 MANUFACTURERS**

- A. The following manufacturers are approved for use. No substitutions will be permitted.
  1. Daikin as basis of design
  2. Miller-Picking
  3. Temtrol
  4. Scott-Springfield
  5. Racan-Carrier Company

**2.02 GENERAL DESCRIPTION**

- A. Configuration: Fabricate as detailed on drawings.
- B. Performance: Conform to AHRI 430. See schedules on prints. (NOTE: Above does not apply to fan array)
- C. Acoustics: Sound power levels (dB) for the unit shall not exceed the following specified levels. The manufacturer shall provide the necessary sound treatment to meet these levels if required.

Octave Band at Center Frequency (Hz)								
	63	125	250	500	1000	2000	4000	8000
Radiated								
Discharge								
Return								

- D. [IBC Certification
  1. All components included herein are designed, manufactured and independently tested, rated and certified to meet the seismic compliance standards of the 2009 International Building Code. Components designated for use in systems that are life safety, toxic, high hazard, combustible or flammable shall meet the on line, anchorage and load path requirements for life safety as defined in IBC sections 1621.1.6, 1621.3.3, 1707.7.2, and IBC Commentary, Volume II, section 1621.1.6, IBC notes pertaining to the release of hazardous material. All components used as part of a system other than the above shall meet as a minimum, all load path and anchorage standards for components as outlined in IBC section 1621.3.3 & 1707.7.2.
  2. Certification is good for [Fp/Wp = 2.89 gs and Sds = 1.29 gs obtained from a "maximum considered earth quake short period spectral response acceleration Ss of 1.93.] [Fp/Wp = 4.42 gs and Sds = 1.96 gs obtained from a "maximum considered earth quake short period spectral response acceleration Ss of 2.94.]
  3. All completed component assemblies shall be clearly labelled for field inspection. Seismic Compliance Labels shall include the manufacturer's identification, designation of certified models, definitive information describing the product's compliance characteristics, and the Independent Certifying Agency's name and report identification.

4. In addition to all seismic requirements for IBC Certification listed elsewhere in the project specification, manufacturer's submittals shall include.
5. Certificate of Compliance from the Independent Certifying Agency clearly indicating that components supplied on this project are included in the component manufacturer's Certificate of Compliance.
6. Clear installation instructions including all accessory components that are part of the overall component installation.]

**2.03 UNIT CONSTRUCTION**

- A. Fabricate unit with 16 gauge channel posts and panels secured with mechanical fasteners. All panels, access doors, and ship sections shall be sealed with permanently applied bulb-type gasket. Shipped loose gasketing is not allowed.
  1. Panels and access doors shall be constructed as a 2-inch (50-mm) nominal thick; thermal broke double wall assembly, injected with foam insulation for an R-value of not less than R-13. The outer panel shall be constructed of G90 galvanized [G60 painted galvanized] [18-gauge] steel. The inner liner shall be constructed of G90 galvanized [solid stainless] steel.
  2. Panel deflection shall not exceed L/240 ratio at 125% of design static pressure, maximum positive or negative 8 inches of static pressure. Deflection shall be measured at the midpoint of the panel height.
  3. Panel assembly shall meet UL standard 1995 for fire safety. Panel assembly shall comply with the material requirements of NFPA 90A.
  4. The casing leakage rate shall not exceed [0.50 cfm per square foot of casing surface area at design static pressure up to a maximum of +5" w.c. in positive pressure sections and -6" w.c. in negative pressure sections (.0025 m³/s per square meter of cabinet area at 1.24 kPa static pressure)] [ASHRAE 111 Class 6 at design static pressure up to a maximum of +8" w.c. in positive pressure sections and -8" w.c. (1.99 kPa) in negative pressure sections, where casing leakage (cfm/100 ft² of casing surface area) =  $C_L \times P^{0.65}$ ] [1% of supply air volume at design static pressure up to a maximum of +8" w.c. in positive pressure sections and -8" w.c. (1.99 kPa) in negative pressure sections].
  5. Module to module assembly shall be accomplished with an overlapping, full perimeter, internal splice joint sealed with bulb type gasketing on both mating modules to minimize on-site labor and meet indoor air quality standards.

6. Factory leakage test available for units selected with high pressure, low leakage construction. The unit manufacturer shall provide a witnessed factory leak test on selected units. The cabinet shall be tested at the unit's positive and negative maximum design operating static pressure, [up to 8" of differential static pressure across the cabinet exterior walls for the entire unit. Cabinet leakage shall not exceed Class 6 leakage per ASHRAE Standard 111 or 1% of supply air volume, whichever is greater] [up to +5"/-6" of differential static pressure across the cabinet exterior walls for the entire unit. Cabinet leakage shall not exceed 0.50 CFM/sq. ft. of casing surface area]. All supply and return opening shall be sealed. Air pressure and flow shall be measured by a third party calibrated and certified apparatus. The testing shall be performed at the factory. Owner's representative shall select on unit to be tested at the time of order. A written test report shall be prepared by the manufacturer and issued to the owner's representative.
7. Factory panel deflection testing available for units selected with high pressure, low leakage construction. The unit manufacturer shall provide a factory deflection test on one unit at the unit's positive and negative maximum design operating static pressure, up to 8" of differential static pressure across the cabinet exterior walls for the entire unit. A deflection limit of L/240 will be demonstrated at this time. "L" is defined as the height of a panel on the side of the unit. Measurement shall be at the mid-point of "L" along the largest panel on one side. Owner's representative shall select on unit to be tested at the time of order. A written test report shall be prepared by the manufacturer and issued to the owner's representative.
8. [A sound baffle shall be secured to the inner liner and constructed of G90 galvanized perforated steel filled with glass fiber insulation.]
9. [An optional 0.044" thick aluminium treadplate shall be secured to the floor panel.]
10. [Entire unit shall have a [4] [6] [8] [10] [12]-inch full perimeter base rail for structural rigidity and condensate trapping. The following calculation shall determine the required height of the baserail to allow for adequate drainage. Use the largest pressure to determine base rail height. [(Negative) (Positive) static pressure (in)] (2) + 4" = required baserail height. Should the unit baserail not be factory supplied at this height, the contractor is required to supply a concrete housekeeping pad to make up the difference.]
- B. Access Doors shall be flush mounted to cabinetry, with minimum of two six inch long stainless steel piano-type hinges, latch and full size (4.5" minimum) handle assembly (provide inspection window for fan section). Door shall swing outward for unit sections under negative pressure (inward for unit sections under positive pressure). Doors limited from swinging inward (such as side access filter sections) on positive pressure sections, shall have a secondary latch to relieve pressure and prevent injury upon access.
- C. Construct drain pans from stainless steel with cross break and double sloping pitch to drain connection. Provide drain pans under cooling coil section [fan section]. Drain connection centerline shall be a minimum of 3" above the base rail to aid in proper condensate trapping. Drain connections that protrude from the base rail are not acceptable. There must be a full 2" thickness of insulation under drain pan.

## 2.04 SUPPLY / RETURN FANS

- A. Provide [DWDI forward-curved] [DWDI airfoil] [belt-drive airfoil plenum] [direct-drive airfoil plenum] [inline] [DWDI forward curved twin] [fan array] supply [return] fan(s). Fan assemblies including fan, motor and sheaves shall be dynamically balanced by the manufacturer on all three planes and at all bearing supports. Manufacturer must ensure maximum fan RPM is below the first critical speed.

### ECM fan array

1. Provide ECM, motorized impeller supply [return] fan(s). Fan assembly shall include fan, fan base, and a motor and shall be dynamically balanced by the fan manufacturer.
  - a. Inverter shall be integral to the motor and come as an assembly from the fan manufacturer.
  - b. Motor shall be brushless DC type with a permanent magnet rotor.
  - c. Fan section shall come equipped with a motor control panel mounted on the supply [return] fan section. Both line voltage and low voltage wiring shall be done by the factory. Each fan shall have an isolation switch.
  - d. [Unit shall be provided with a ship loose motor control panel for the supply [return] fan section. All motor wiring shall be field supplied and installed]
  - e. Motor control panel shall come equipped with a fused disconnect
  - f. Motor control panel shall come with a low voltage terminal strip and shall include terminals for Fan ON/OFF, 0-10V signal, and fan fault.
  - g. ECM motor control panel SCCR shall be at least 65kA
  - h. [Unit shall come equipped with an isolation damper upstream of each fan in the array. Damper shall be equipped with an adjustable, weighted counter balance to minimize static pressure loss]



**DDPL fan array**

1. Fan array shall have number of fans as scheduled.
2. Fan array section shall come with sound absorbing panels installed around each fan.
3. Fan array shall have fans individually isolated with [Rubber in Shear(RIS)][spring] isolation.
4. Access section placed downstream for motor access. [Section shall come installed with tread plate installed in the floor. [Section shall come with motor removal hoist installed]
5. [Unit shall be equipped with a manual block-off plate for mounting in the fan inlet][Unit shall come equipped with an isolation damper upstream of each fan in the array. Damper shall be equipped with an adjustable, weighted counter balance to minimize static pressure loss][Unit shall come equipped with an actuated damper upstream of each fan. An external signal shall close the damper in the event of a fan failure.]
6. [Fan array section shall come with an externally mounted junction box to allow for field wiring of the fan array motors]
7. [Fan section shall come equipped with motor control panel with short circuit protection complete with variable frequency drives.]
  - a. [Fan array shall be equipped with one variable frequency drive wired to all fans][Fan array shall have a redundant drive wired to all fans]
  - b. [Fan array shall be equipped with one variable frequency drive wired to all fans in a given row in the fan array.]
  - c. [Fan array shall be equipped with on variable frequency drive wired to each of the fans in the fan array]
8. [Motor control panel shall come equipped with a [fused][non-fused] disconnect switch]
9. [Fan array shall be equipped with Piezometer rings to measure airflow][One piezometer ring shall be supplied on [each fan][each row][one fan] in the fan array]

**Multiple direct-drive fans**

1. Unit shall have [two] [three] [9] [12] blade direct-drive class II fans with [2" spring isolation] [rubber-in-shear isolation (fan sizes 36 and smaller)] [2" seismic isolation].
2. [Manual block-off] [Isolation damper [with actuator]] mounted upstream of fan for isolation of individual fans.
3. [Single source power motor control panel with short circuit protection and [Non-fused disconnect] [fused disconnect] [Circuit breaker] factory wired from panel to motors in conduit. Variable speed control by [McQuay brand VFD(s)] [ABB] [Danfoss].] [Fan on-off and speed control by others shall be provided.]

**Q-PAC fan array**

1. The fan array will be arranged with high performance direct drive, single inlet, plenum fans with backwards inclined, high efficiency

welded-aluminum or high-performance composite impeller with galvanized or aluminum support frame.

2. Manual blank-off plates shall be provided to block fan airflow, one plate to be provided per array. [Optional Backdraft dampers shall be provided to block fan airflow in lieu of blank-off plates.]
3. The fans are driven by long-life, low-temperature brushless DC electronically commutated motor (EC-Motor) with external rotor and integrated maintenance-free electronic circuitry and electronics. The motor is manufactured with maintenance-free, permanently lubricated ball bearings and shall be statically and dynamically balanced in accordance with ISO 1940 part 1. The motor shall be closed, protection level IP 54, thermal class 155 with permissible operating temperature of -13°F to 140°F. Motor efficiency class shall comply with IE4. Fan characteristic curves indicate measurements on a chamber test in accordance with ISO5801. The three-phase external rotor motor integrated into the fan hub meets the requirements for circulating electric machines set forth in DIN EN 60 034-1 (VDE 0530 Part 1).
  - a. Fan Array shall be listed per UL 1995.
  - b. Fan assemblies shall be prewired with wire whips and plug connectors.
  - c. Fan system manufacturer must stock replacement parts in North America.
4. The fan bulkhead wall shall be constructed in a manner for easy field assembly, constructed of 14 gauge G90 formed sheet metal. The bend profile at each panel's seam shall provide vertical structural support for the bulkhead wall.
5. The control panel shall include an external disconnect and shall be UL or ETL listed. [Each panel contains a lockable Hand/Off/Auto switch for optional manual speed control. The panel accepts a 0-10VDC signal when in Auto mode and can be controlled locally when in Hand Mode.] [The panel shall be provided with a BACnet compatible controller capable of monitoring the array's airflow, total static pressure, power consumption, RPM, and individual fan alarm status and specific cause of alarm. Controller shall be configurable for fan speed control via BACnet interface (MS/TP), 0-10 VDC input, 4-20 mA input, constant airflow, or duct static pressure (static pressure sensor to be field provided and mounted). Control panel shall be equipped with relays for locking between other electrically driven components.]
6. There is a system alarm contact that the BAS can use to check the status of the Q-PAC System. There is a system enable contact that the BAS can use to enable or disable the Q-PAC System, along with a safety circuit terminations.
7. All Q-PAC components shall be sized to fit through a 20" x 40" access opening.



- B. Bearings shall be self-aligning, grease lubricated, ball or roller bearings with extended copper lubrication lines to access side of unit. Grease fittings shall be attached to the fan base assembly near access door. If not supplied at the factory, contractor shall mount copper lube lines in the field.
- C. Fan and motor shall be mounted internally on a steel base. Factory mount motor on slide base that can be slid out the side of unit if removal is required. Provide access to motor, drive, and bearings through hinged access door. Fan and motor assembly shall be mounted on [rubber-in-shear vibration type isolators inside cabinetry.] [2" deflection spring vibration type isolators inside cabinetry] [unit base, rigid mounted.] [Seismic snubbers shall be provided.]

## 2.05 BEARINGS AND DRIVES

(Not applicable for fan array or direct-drive fans)

- A. Bearings: Basic load rating computed in accordance with AFBMA - ANSI Standards, [L-50 life at 200,000 hours – all DWDI fans] [L-50 life at 500,000 hours – DWDI fans on unit sizes 003 - 035], [L-50 life at 400,000 hours all belt-drive airfoil plenum fans and DWDI fans on unit sizes greater than 035] [L-50 life 1,000,000 hours – DWDI fans on unit sizes 003 – 035] [L-50 life at 600,000 hours – all inline fans], heavy duty pillow block type, self-aligning, grease-lubricated ball bearings.
- B. Shafts shall be solid, hot rolled steel, ground and polished, keyed to shaft, and protectively coated with lubricating oil. Hollow shafts are not acceptable.
- C. V-Belt-drives shall be cast iron or steel sheaves, dynamically balanced, bored to fit shafts and keyed. [Fixed sheaves, matched belts, and drive rated based on motor horsepower] [Variable and adjustable pitch sheaves selected so required RPM is obtained with sheaves set at mid-position and rated based on motor horsepower. Contractor to furnish fixed sheaves at final RPM as determined by balancing contractor]. Minimum of 2 belts shall be provided on all fans with 10 HP motors and above. Standard drive service factor shall be [1.1 S.F. (for 1/4 HP – 7.5 HP)] [1.3 S.F. (for 10HP and larger)], calculated based on fan brake horsepower.

## 2.06 ELECTRICAL

- A. The air handler(s) shall be ETL and ETL-Canada listed by Intertek Testing Services, Inc. Units shall conform to bi-national standard ANSI/UL Standard 1995/CSA Standard C22.2 No. 236.
- B. Wiring Termination: Provide terminal lugs to match branch circuit conductor quantities, sizes, and materials indicated. Enclosed terminal lugs in terminal box sized to NFPA 70.
- C. [Provide [marine light] [marine light and GFI receptacle] in [fan] [each] section mounted and wired to a junction box and on-off switch mounted on the outside of the cabinet.
- D. Fan motors shall be [1200] [1800] [3600] rpm, [open drip-proof (ODP)] [ totally enclosed fan-cooled (TEFC)] [1800/ 1200 rpm, 2 Speed/2 Winding (ODP) (TEFC)] [1800/900 rpm, 2 Speed/1 Winding (ODP) (TEFC)] type. Motors shall be [standard efficiency.] [high efficiency to meet EPA requirements.] [premium efficiency.] Electrical characteristics shall be as shown in schedule.
- E. [Air handler manufacturer shall provide and mount conduit and wiring from each fan motor terminated at [an external junction box.] [a non-fused] [a fused] [a circuit breaker] type disconnect switch factory wired. The disconnect switch shall be furnished with a rotary or switch-blade type handle that can be padlocked in the 'off' position.] [A motor starter [IEC] [NEMA] type shall be provided.]
- F. [Air handler manufacturer shall provide and mount [Daikin] [ABB] [Danfoss] variable speed drive with electrical characteristics as shown on project schedule. [A two-contactor type bypass switch shall be provided.] [A line reactor shall be provided.]
- G. Air handler manufacturer shall provide and mount a handoff-auto (HOA) switch.]
- H. [Air handler manufacturer shall provide and mount a [24V] [120V] transformer.]
- I. [Manufacturer must provide ASHRAE 90.1 Energy Efficiency equation details for individual equipment to assist Building Engineer for calculating system compliance.]

- J. [Ultraviolet Light Germicidal Irradiation (UVGI) System]
1. The UVGI surface irradiation system shall consist of heavy duty, factory assembled and tested light fixtures that emit short wave UVC light (200 nm – 270 nm)
  2. Constructed and tested for HVAC environments: UL listed at 55°F to 135°F with airflow velocities up to 1000 FPM. Independently tested to verify output and performance. UVGI system shall have UL Approval per Category Code ABQK (Accessories, Air Duct Mounted) UL Standards: UL153, UL1598 & UL1995.
  3. Assembly shall consist of double ended UVC florescent lamp and housing, power source and sockets shall be UL Drip proof construction.
  4. The enclosure shall be made of drip-proof construction from galvanized steel. The ballast shall be a self-contained electronic type. The enclosure shall include safety mechanical interlocks which do not allow the UV assembly to light unless installed on its track. The multiple UV assemblies shall connect via interlock.
  5. UVC Lamp shall be a standard output hot cathode, low pressure T8, double ended UVC lamp. Lamps shall be constructed with a thick wall glass of soda barium UV transparent glass with a base of metal. Lamps shall have 5.5 milligrams or less of mercury.
  6. Lamps shall produce adequate UV output and operate in environments of temperatures between 55°F to 135°F. Lamps shall produce a minimum of 80% of initial UV output at end of life (9000 hours minimum).
  7. Power source shall be 120 VAC 60hz. Power connections shall be via a provided j-box or line cord from one end of the UV fixture. UV fixtures shall electrically connect via interlocks.
  8. Installation shall be such that the cumulative sum length of UV fixtures end-to-end shall equal the coil width +/- three (3) inches. Modular coil system shall be installed and wired so that the entire surface of the coil and drain pan is bathed by UVC. System shall be installed using “tracks” to allow UV fixture to slide into place, for ease of access during installation and annual maintenance. System shall be installed 8"-20" (14" ideal) from coil surface. System shall be installed utilizing one row of lamps for every 48" of coil height. System shall incorporate safety “cut-off” switches on access doors.
  9. Approved manufacturers: UltraViolet Devices, Inc. (UVDI).

## 2.07 COOLING AND HEATING COIL SECTIONS

- A. Provide access to coils from [both sides] [connection side] [opposite side] of unit for service and cleaning. Enclose coil headers and return bends fully within unit casing. Unit shall be provided with coil connections that extend a minimum of 5" beyond unit casing for ease of installation. Drain and vent connections shall be provided exterior to unit casing. Coil connections must be factory sealed with grommets on interior and exterior and gasket sleeve between outer wall and liner where each pipe extends through the unit casing to minimize air leakage and condensation inside panel assembly. If not factory packaged, Contractor must supply all coil connection grommets and sleeves. Coils shall be removable through side and/or top panels of unit without the need to remove and disassemble the entire section from the unit.
1. Identify fin, tube & casing material type and thickness.
  2. Show coil weights (shipping & operating).
  3. State air and fluid flow amounts with its associated pressure drops. For steam coils, indicate steam pressure and condensate load.
  4. Indicate entering & leaving air and water temperatures. For refrigerant coils, indicate saturated suction temperature (SST).
  5. [Manufacturer to provide and mount ultraviolet lights on the leaving air side of the cooling coil(s) and over the drain pan to meet GSA 2003 Facilities Standard - 5.9 HVAC Systems and Components and agency approved to UL category Code ABQK specification, HVAC Accessories, Air Duct Mounted.]
- B. Water Coils:
1. Certification - Acceptable water coils are to be certified in accordance with AHRI Standard 410 and bear the AHRI label. Coils exceeding the scope of the manufacturer’s certification and/or the range of AHRI’s standard rating conditions will be considered provided the manufacturer is a current member of the AHRI Air-Cooling and Air-Heating Coils certification programs and that the coils have been rated in accordance with AHRI Standard 410. Manufacturer must be ISO 9002 certified.
  2. Headers shall consist of seamless copper tubing to assure compatibility with primary surface. Headers to have intruded tube holes to provide maximum brazing surface for tube to header joint, strength, and inherent flexibility. Header diameter should vary with fluid flow requirements.

3. Fins shall have a minimum thickness of [[0.0075"] [0.0095"] of aluminum] or [0.006"] [0.0075"] [0.0095"] copper]] plate construction. Fins shall have full drawn collars to provide a continuous surface cover over the entire tube for maximum heat transfer. Tubes shall be mechanically expanded into the fins to provide a continuous primary to secondary compression bond over the entire finned length for maximum heat transfer rates. Bare copper tubes shall not be visible between fins.
  4. Coil tubes shall be 5/8 inch (16mm) OD seamless copper, 0.020" [0.025"] [0.035"] [0.049"] nominal tube wall thickness, expanded into fins, brazed at joints. Soldered U-bends shall be provided to minimize the effects of erosion and premature failure having a minimum tube wall thickness of 0.025".
  5. Coil connections shall be [N.P.T. threaded carbon steel] [butt weld carbon steel] [O.D. sweat copper] [threaded red brass] with connection size to be determined by manufacturer based upon the most efficient coil circuiting. Vent and drain fittings shall be furnished on the connections, exterior to the air handler. Vent connections provided at the highest point to assure proper venting. Drain connections shall be provided at the lowest point to ensure complete drainage and prevent freeze-up.
  6. Coil casings shall be a formed channel frame of [galvanized steel] [stainless steel]. Water heating coils, 1 & 2 row only (sans 5M type) shall be furnished as uncased to allow for thermal movement and slide into a pitched track for fluid drainage.
- C. Refrigerant Coils:
1. Manufacturer must be ISO 9002 certified.
  2. Coils designed for use with Refrigerant [R-22] [R134a] [R410a] [other]. Fins shall have a minimum thickness of [[0.0075"] [0.0095"] of aluminum] or [0.006"] [0.0075"] [0.0095"] copper]] plate construction with full drawn collars to provide a continuous surface cover over the entire tube for maximum heat transfer. Tubes shall be mechanically expanded into the fins to provide a continuous primary-to-secondary compression bond over the entire finned length for maximum heat transfer rates. Bare copper tube shall not be visible between fins.
  3. Refrigerant coils shall be provided with round seamless 5/8" O.D. copper tubes on 1-1/2" centers, staggered in the direction of airflow. All joints shall be brazed.
  4. Sweat type copper suction connections located at the bottom of the suction headers for gravity oil drainage. Coils shall be uniformly circuited in a counterflow manner for [single circuit] [row] [face] [interlaced] [interlaced face split] capacity reduction. Pressure type liquid distributors used. Coils shall be tested with 315 pounds air pressure under warm water, and suitable for 250 psig working pressure.
- D. Steam Coils:
1. Certification - Acceptable steam coils are to be certified in accordance with AHRI Standard 410 and bear the AHRI label. Coils exceeding the scope of the manufacturer's certification and/or the range of AHRI's standard rating conditions will be considered provided the manufacturer is a current member of the AHRI Air-Cooling and Air-Heating Coils certification programs and that the coils have been rated in accordance with AHRI Standard 410. Manufacturer must be ISO 9002 certified.
  2. Fins shall have a minimum thickness of [[0.0075"] [0.0095"] [0.012" (1" dia. tubes only)] of aluminum] or [0.006" (5/8" tube dia. only)] [0.0075"] [0.0095"] copper]] with full drawn collars to provide a continuous surface cover over the entire tube for maximum heat transfer. Tubes shall be mechanically expanded into the fins to provide a continuous primary-to-secondary compression bond over the entire finned length for maximum heat transfer rates. Bare copper tubes shall not be visible between fins.
  3. Steam coils shall be provided with round seamless [5/8" O.D. copper [0.020"] [0.025"] [0.035"] [0.049"] or [1" O.D. copper [0.025"] [0.049"] tubes. Tubes on two-row coils are staggered in the direction of airflow. All joints shall be brazed.
  4. Steam coil headers shall be made of nonferrous materials using seamless copper tubing with intruded tube holes to permit expansion and contraction without creating undue stress or strain. Both the supply and return headers shall be completely encased by the coil casing. Coil shall be pitched in the unit to assure positive condensate drainage. Steam coils shall be furnished as uncased to allow for thermal movement and slide into a pitched track for drainage. Orificed baffle plates shall be installed in the supply connection to ensure proper diffusion of entering steam.
  5. Steam coils shall be tested with 315 pounds air pressure under warm water and suitable for 150 psig working pressures.

- E. [Horizontal Tube Integral Face and Bypass Coil
1. Horizontal tube integral face and bypass coils shall consist of multiple alternating heating sections and bypass sections, with airflow distributed to each by interlocking wrap-a-round "clamshell" style dampers; linkage to be stainless steel. Coils shall be suitable for hot water or steam and continuous operation at 200 psig and 400 F degrees. Heating elements to consist of multi-row, multi-pass extended heat transfer surface; coil shall carry AHRI 410 certification as to ratings. Welding and brazing shall be done by ASME qualified personnel.
  2. Tubes shall be 5/8" diameter seamless copper, 0.035" average wall thickness. Fins shall be continuous patterned plate, 0.0075" thick aluminum with full fin collars. Joints shall be silver brazed.
  3. Headers shall be single piece carbon steel, with no separate disks or caps welded or brazed into header ends. Connections shall be steel and shall be welded to header barrels.
  4. Casings and dampers shall be minimum 16 gauge mill galvanized steel; top and bottom casing panels to be double flanged for stacking. End casings shall have smooth, embossed tube holes to provide adequate bearing surface for tubes to avoid abrasion during expansion and contraction. Flexible connectors shall not be required.]
- F. [Vertical Tube Integral Face and Bypass Coil
1. Vertical tube integral face and bypass coils shall consist of multiple alternating heating sections and bypass sections, with airflow distributed to each by interlocking wrap-a-round "clamshell" style dampers; linkage to be stainless steel. Coils shall be suitable for hot water or steam and continuous operation at 200 psig and 400 F degrees. Heating elements to consist of multi-row, multi-pass extended heat transfer surface; coil shall carry AHRI 410 certification as to ratings. Welding and brazing shall be done by ASME qualified personnel.
  2. Hot water applications shall be furnished with 5/8" outside diameter tubes with .035" tube wall thickness. Steam applications shall be furnished with a non-freeze, tube-within-a-tube design that consists of an outer tube that is 5/8" outside diameter tubes with 0.035" tube wall thickness and an inner tube that is 3/8" outside diameter with 0.020" wall thickness. Fins shall be a helical fin design that is 1/2" high, 0.012" thick copper, solder coated.
  3. Supply and Return headers shall be located at the base of the coil. Hot water coils shall employ return bends. Steam coils shall be capped to allow free thermal movement. Headers shall be carbon steel with male pipe thread connections.
  4. The casing shall be 12 gauge galvanized steel. The dampers shall be 16 gauge galvanized steel with aluminum hinges, stainless steel pins, linkage & connecting bars with oilite bearings.]

## 2.08 GAS HEAT MODULE

- A. The air handling unit shall include a natural gas heating section. The gas furnace shall be natural gas fired heating module(s) factory installed downstream of the supply air fan in the heat section.
- B. [The heating module shall be a tubular design with in-shot gas burners. The heat exchanger tubes shall be constructed of stainless steel. The module shall have an induced draft fan that will maintain a negative pressure in the heat exchanger tubes for the removal of the flue gases.] [High efficiency heat exchanger shall be a primary drum and multi-pass tubular secondary constructed of titanium stainless steel, and shall be of a floating design to minimize stresses during heating and cooling cycles. Tubing used for the heat exchanger shall comply with ASTM A268 or ASTM 249 (as applicable). Secondary tubes shall be swaged into panels and welded to provide a secure joint and air tight assembly. All heat transfer surfaces shall be inside the casing and in the air stream.]
- C. [Gas-fired duct furnaces provided shall have a tubular heat exchanger constructed of (Type 409 Stainless Steel .044 minimum wall thickness produced to ASTM A268).]
- D. [Duct furnace to provide a minimum combustion efficiency of 90% through the entire firing range, exceeding the ASHRAE 90.1 minimum requirement for steady state efficiency.]
- E. [High efficiency gas heat section shall be provided with condensate drain(s). Installer is responsible for materials and final connection of drain(s) for condensate disposal.]
- F. [High efficiency furnaces require a Category IV venting system certified to UL 1738 / ULC S636. Installer is responsible for material and final vent installation in accordance with manufactures instructions provided.]
- G. The Duct Furnace models shall be listed by Intertek Testing Services (ITS / ETL) for operation on Natural or Propane gas to the current edition of ANSI Z83.8 Standard for Gas-Fired Duct Furnaces. Duct furnaces are for installation on the positive pressure side of the circulating air blower, only.
- H. [Gas Module shall be [2] [4] stages of control] [Gas module shall have [5:1] [10:1] [20:1] [25:1] modulating control.]
  - I. Each burner module shall have [two flame roll-out safety protection switches and] a high temperature limit switch that will shut the gas valve off upon detection of improper burner manifold operation.
  - J. The induced draft fan shall have an airflow safety switch that will prevent the heating module from turning on in the event of no airflow in the flue chamber.
- K. Field installed heating modules shall require a field ETL certification. The manufacturer's rooftop unit ETL certification shall cover the complete unit including the gas heating modules.



- L. Individual Duct Furnaces shall incorporate a Direct Spark Ignition control module that is design certified by a recognized national testing agency. The control shall provide:
  1. 100% safety shut-off
  2. A 15 second minimum pre-purge period prior to trial for ignition
  3. High energy direct spark ignition of main burners
  4. Electronic flame supervision incorporating a 0.8 second flame failure response time
  5. Up to 2 additional ignition retries preceded by an interpurge period
  6. A minimum 30 second post-purge
  7. Automatic reset after one hour to initiate additional ignition trials if lockout occurs during heat call
  8. An LED indicator light to provide a flash code to identify the operating condition of the control

## 2.09 PARTICULATE FILTERS

- A. [Filter section with filter racks and guides with hinged and latching access doors on either, or both sides, for side loading and removal of filters] [Filter section with front loading frames and clips].
- B. Filter media shall be UL 900 listed, Class I or Class II.
- C. [Flat] [Angle] arrangement with [2", 50mm] [4", 100mm] deep [pleated] [disposable] panel filters.
- D. [Bag] [Cartridge] type arrangement with holding frames suitable for [2" (50 mm)], [4" (100 mm)] prefilter and final filter media and blank-off sheets, extended surface [bag] [cartridge] media filters with [60-65] [80-85] [90-95] percent dust spot efficiency. Bag filter media [12" (305 mm )] [15" (381 mm)] [19" (483 mm)] [22" (559 mm)] [30" (762 mm)] [36" (914 mm)] deep. Cartridge filter media is [4" (50 mm)] [12" (305 mm)] deep. [Provide microbial resistant Intersept® coating on all filters.] Designed for [side] [front] loading of filters.
- E. [Furnish combination filter section with 2-inch flat pre-filter and 12-inch HEPA - 99.97% coefficient (MERV 16) final filter. Provide front-loading and removal of filters. Filter media shall be UL 900 listed, Class I or Class II.]
- F. [Manufacturer shall supply minihelic gauge to read pressure drop across the filter bank for scheduling filter replacement. Design shall be equal to a Dwyer Minihelic 2 and be recessed into the cabinet to minimize chances for damage during shipment and installation.]
- G. [Manufacturer to provide and mount ultraviolet lights on the entering air side of the filter. Ultraviolet lights must meet agency approved to UL category Code ABQK specification, HVAC Accessories, Air Duct Mounted.]

## 2.10 [GAS-PHASE FILTRATION]

- A. Side access tracks shall accommodate AAF International's [Cleanroom Grade (CG)] [Medium Duty (MD)] [Heavy Duty (HD)] gas-phase filter cassettes.
- B. The filter enclosure shall include side access extruded aluminum tracks to support the gas phase filter cassettes. Each gas phase filter shall be supported by two upper and lower extruded aluminum tracks i.e. two support tracks at the inlet face and two support and sealing tracks at the outlet face.
- C. These tracks shall incorporate formed profile features to ensure that the filters are properly sealed into the enclosure. Simple 'L' tracks or angle supports that permit high leakage and inefficient sealing integrity are not permitted. The filter tracks shall ensure that the gas phase filter cassettes are permanently fixed in position and sealed to minimize bypass of air around the filters and to ensure that the entire contaminated air-stream passes through the filters.
- D. Each filter track shall include two hard-extruded type POM plastic strips embedded into, and protruding above, the horizontal surface of the track. These strips will minimize the surface area in contact with the filter cassettes and provide a plastic sliding surface with inherent lubricating properties to minimize friction and facilitate ease of installation and removal when sliding the gas phase filters into and out of the tracks.
- E. The filter outlet face (or downstream) upper and lower support and sealing tracks will each include a tubular, compressible, EPDM gasket inserted into a formed cavity in the sealing face of the track. Each of these tracks shall also include a vertical extruded aluminum flange that shall guide the gas phase filter into position and position the filter to guarantee that the tubular gasket is adequately compressed to seal between the filter and the track to minimize any by-pass of unfiltered air. The tubular gasket shall be treated with a polymer coating to reduce friction when sliding the gas phase filter into the track.
- F. The vertical flange in the track shall fit into notches located on the gas phase filter cassette and ensure that the cassette is properly positioned in the track. The tubular gasket shall be compressed by the action of installing the gas phase cassette into the side access tracks.
- G. The cassette shall be formed completely from injection molded, recyclable (or incinerable), high-impact polystyrene (HIPS). The plastic components that form the cassette shall be connected together using internal high pressure, snap-lock connectors formed into the connecting components. No glues or solvents shall be allowed to be used in the manufacture or construction of the cassette to prevent contamination of both the chemical media and the air-stream by off-gassing of VOCs.

- H. All surfaces of the cassette should be true and offer external squareness. The cassette construction shall be of precision close tolerance construction having external dimensional and square ness tolerances of +/- 2mm. The cassette shall be capable of operating effectively in humidity range of 5% - 99% and temperature range of -5°F (-20°C) to 130°F (55°C).
- I. Chemical media shall be supported between aerodynamically tapered screens with very low drag coefficient (for energy efficiency). Injection molded high-impact polystyrene screens shall form individual media beds assembled into a V-bank configuration.
- J. No nose cavities shall be allowed in cassettes. The inlet and outlet screens shall be parallel and the inlet and outlet face areas shall be equal to ensure equal and complete utilization of the chemical media. The screen openings shall have a maximum width of 2-mm to ensure full retention of the chemical media and to eliminate downstream fouling.
- K. The screens shall be structurally reinforced with molded plastic ribs to minimize deflection of the screen caused by the weight of the chemical media. The ribs shall span in both directions and shall be orthogonal to each other. The inlet and outlet screens shall have a minimum thickness of 1.90-mm. A spacer shall be utilized at 150-mm intervals to accurately distance the two screens and maintain squareness and a constant bed depth after filling with chemical media.
- L. The side plates of the cassette shall be completely flat and planar and without protrusions to ensure that adjacent cassette mate accurately. All flanges shall be internal. No external flanges shall used. A 25mm wide gasket shall be mounted on each side plate to seal between adjacent cassettes. A scribed line formed into the side plate during molding shall determine the accurate positioning of the gasket. The gasket shall extend completely from the bottom to the top of the side plate and the edge of the gasket shall be contiguous with the face of the cassette. The gasket material shall be adhesive coated (with an acryl-based adhesive), semi-closed-cell EPDM foam and shall have a Durometer of 50-70. The material shall have good resistance to UV, humidity, high and low temperatures, and chemicals such as acids and alkalis, and fats and grease.
- M. A V-shaped Butterfly® Gasket shall be located horizontally along the upper and lower edges of the air leaving, or sealing, face of the cassette when the cassette is oriented for horizontal airflow. Two (2) 10-mm long, 0.5-mm thick, flexible "wings" shall be molded into a 16-mm wide, 1.5mm thick, base. When the cassette is installed the wings of the Butterfly gasket shall engage and envelop the tubular gasket that is installed in the extruded aluminum track providing a complete seal. The Butterfly gasket shall be extruded Polyurethane plastic.
- N. No heavy metals (such as Cadmium) nor regulated substances, such as CFC's and halogen gases shall be used during the manufacturing process nor be contained in the product itself.
- O. Cassette side plates shall not incorporate the cassette filling ports. Chemical media filling ports shall be located on the face of the cassette. The ports shall be covered and sealed using reinforced injection molded polypropylene covers. The covers shall be fixed to the cassette at a minimum of three locations, being each end and in the center, with high strength, bayonet style, plastic rivets. The bayonet shall cause the rivet to expand and form a tight connection. The end of the bayonet shall be barbed to prevent withdrawal and loosening of the connection, it shall also completely plug the center of the rivet and prevent air leakage through the rivet.
- P. The sealing perimeter of the cassette face shall be completely planar with top, bottom and side flange faces being completely flush. No setbacks or gaps shall be allowed. The outer edges of the top and bottom flanges shall be completely flush with the top and bottom surfaces of the cassette.
- Q. The cassette shall include a precision molded slot positioned to accept a guide located on the surface of the support track. The slot and guide combination will ensure that the cassette is accurately positioned in the mounting track ensuring full contact and proper compression of the track-mounted gasket.
- R. Physical characteristics and performance shall be as follows: [Cleanroom Grade (CG) Cassette – Nominal size 24"H x 12"W x 12"D with media holding capacity of 0.7 cubic feet in a 1" thick 'V' bank arrangement. Rated pressure drop at 500 fpm shall be [0.047 utilizing SAAFOxidant] [0.56 utilizing SAAFCarb] [0.57 utilizing SAAFBlend] Chemical Media. Chemical media utilization index shall be 92% or greater.] [Medium Duty (MD) Cassette – Nominal size 6"H x 24"W x 18"D with media holding capacity of 0.5 cubic feet in a 1" thick 'V' bank arrangement. Rated pressure drop at 500 fpm shall be [0.031 utilizing SAAFOxidant] [0.35 utilizing SAAFCarb] [0.34 utilizing SAAFBlend] Chemical Media. Chemical media utilization index shall be 92% or greater.] [Heavy Duty (HD) Cassette – Nominal size 12"H x 24"W x 12"D with media holding capacity of 1.0 cubic feet in a 3" thick 'V' bank arrangement. Rated pressure drop at 250 fpm shall be [.073 utilizing SAAFOxidant] [0.87 utilizing SAAFCarb] [0.97 utilizing SAAFBlend] Chemical Media. Chemical media utilization index shall be 92% or greater.]

## 2.11 ADDITIONAL SECTIONS

- A. [Mixing box section shall be provided with [end] [top] [bottom] [left] [right] [no] outside air opening and [end] [top] [bottom] [left] [right] [no] return air opening.
1. [Outside air] [Return air] damper[s] shall be low leak, hollow core galvanized steel airfoil blades, fully gasketed and have continuous vinyl seals between damper blades in a galvanized steel frame. Dampers shall have stainless steel jamb seals along end of dampers. Connecting linkage and ABS plastic end caps shall be provided when return and outside air dampers are each sized for full airflow. Return and outside air dampers of different sizes must be driven separately. Damper Leakage: Leakage rate shall be less than two tenths of one percent leakage at 2 inches static pressure differential. Leakage rate tested in accordance with AMCA Standard 500.
  2. [Outside air] [Return air] damper[s] shall be Tamco 9000, [parallel] [opposed] blade, thermally insulated control damper. Return and outside air dampers must be driven separately.
    - a. Extruded aluminum (6063-T5) damper frame is not less than 0.080" (2.03 mm) in thickness. Damper frame is 4" (101.6 mm) deep × 1" (25.4 mm), with mounting flanges on both sides of frame.
    - b. Blades are extruded aluminum (6063-T5) airfoil profiles, internally insulated with expanded polyurethane foam and thermally broken. Complete blade has an insulating factor of R-2.29 and a temperature index of 55 (tested to AAMA 1502.7 Test Method).
    - c. Blade seals are extruded EPDM. Frame seals are extruded silicone. Seals are secured in an integral slot within the aluminum extrusions. Blade and frame seals are mechanically fastened to prevent shrinkage and movement over the life of the damper.
    - d. Bearings are composed of a Celcon inner bearing (fixed around a 7/16" (11.11 mm) aluminum hexagon blade pivot pin) rotating within a polycarbonate outer bearing inserted in the frame. This eliminates action between metal-to-metal or metal-to-plastic riding surfaces.
    - e. Adjustable 7/16" (11.11 mm) hexagonal drive rod, U-bolt fastener, and hexagonal retaining nuts are zinc-plated steel. These provide a positive connection to blades and linkage.
    - f. Aluminum and corrosion-resistant zinc-plated steel linkage hardware is installed in the frame side, complete with cup-point trunnion screws for a slip-proof grip.
    - g. Dampers are designed for operation in temperatures ranging from -40°F (-40°C) to 212°F (100°C).
  3. [Outside air] [Return air] damper[s] shall be Tamco 1000, [parallel] [opposed] blade, low leak airfoil control damper. Return and outside air dampers must be driven separately.
    - a. Extruded aluminum (6063-T5) damper frame is not less than 0.080" (2.03 mm) in thickness. Damper frame is 4" (101.6 mm) deep × 1" (25.4 mm), with mounting flanges on both sides of frame.
    - b. Blades are extruded aluminum (6063-T5) airfoil profiles.
    - c. Blade seals are extruded EPDM. Frame seals are extruded silicone. Seals are secured in an integral slot within the aluminum extrusions. Blade and frame seals are mechanically fastened to prevent shrinkage and movement over the life of the damper.
    - d. Bearings are composed of a Celcon inner bearing (fixed around a 7/16" (11.11 mm) aluminum hexagon blade pivot pin) rotating within a polycarbonate outer bearing inserted in the frame. This eliminates action between metal-to-metal or metal-to-plastic riding surfaces.
    - e. Adjustable 7/16" (11.11 mm) hexagonal drive rod, U-bolt fastener, and hexagonal retaining nuts are zinc-plated steel. These provide a positive connection to blades and linkage.
    - f. Aluminum and corrosion-resistant zinc-plated steel linkage hardware is installed in the frame side, complete with cup-point trunnion screws for a slip-proof grip.
    - g. Dampers are designed for operation in temperatures ranging from -40°F (-40°C) to 212°F (100°C).
    - h. Leakage Class 1A at 1 in w.g. (0.25 kPa) static pressure differential. Standard air leakage data is certified under the AMCA Certified Ratings Program.
    - i. Dampers are custom made to required size, without blanking off free area.

4. [Outside air] [Return air] damper[s] shall be Ruskin CD60, [parallel] [opposed] blade, low leak airfoil control damper. Return and outside air dampers must be driven separately.
  - a. Control dampers shall be produced in an ISO9001 certified factory.
  - b. Frame shall be one-piece uniframe construction of 16 ga. (1.6) galvanized steel roll formed hat channel structurally equivalent to a minimum 13 ga. (2.4) frame.
  - c. Blades shall be 14 ga. (2.0) equivalent galvanized steel, roll-formed airfoil type for low pressure drop and low noise generation.
  - d. Blade edge seals shall be Ruskiprene™ TPV type or equivalent mechanically locked into the blade edge. Adhesive or clip-on type seals are unacceptable.
  - e. Jamb seals shall be stainless steel chambered compression type to prevent leakage between blade end and damper frame. Blade end overlapping frame is unacceptable.
  - f. Multiple section dampers must have factory installed jackshafts unless clearly eliminated by engineer.
  - g. Bearings shall be 304 stainless steel, oil impregnated, and self-lubricating sleeve type with a 450 pound (204 kg) minimum radial crush load. Bearings shall turn in extruded holes in the damper frame.
  - h. Axles shall be hexagonal positively locked into the damper blade.
    - i. Linkage shall be concealed out of airstream, within the damper frame to reduce pressure drop and noise.
    - j. Temperature limits shall be -72°(-58°C) to +275°F (+135°C).
  - k. Damper shall be tested and licensed in accordance with AMCA 511 for Air Performance and Air Leakage.
  - l. Damper widths from 12" to 60" (305 to 1524) wide shall not leak any greater than 3 cfm/sq.ft. at 1" w.g. (15.2 l/s-m<sup>2</sup> at .25 kPa).
  
5. [Outside air] [Return air] damper[s] shall be Greenheck VCD33 [stainless steel] [galvanized], [parallel] [opposed] blade, low leak airfoil control damper. Return and outside air dampers must be driven separately.
  - a. Dampers shall consist of: a 16 ga. (1.5mm) [galvanized steel] [304 stainless steel] channel frame with 5 in. (127mm) depth; airfoil shaped, [galvanized steel] [304 stainless steel] double skin construction blades (14 ga. [2mm] equivalent thickness); blades shall be completely symmetrical relative to their axle pivot point, presenting identical resistance to airflow in either direction or pressure on either side of the damper; 1/2 in. (6mm) dia. plated steel axles turning in synthetic (acetal) sleeve bearings; TPE blade seals for 200°F (93°C) maximum temperature; flexible stainless steel jamb seals; and external (out of the airstream) blade-to-blade linkage.
  
6. [Outside air] [Return air] damper[s] shall be Greenheck VCD43 aluminum, [parallel] [opposed] blade, low leak airfoil control damper. Return and outside air dampers must be driven separately.
  - a. Dampers shall consist of: heavy gauge aluminum frame (0.125 in. [3.2mm] thick) with 5 in. (127mm) depth formed into a structural hat channel shape; airfoil shaped, extruded aluminum blades (0.063 in. [1.6mm] thick) with metal blade to blade overlap (seal to seal only contact is not acceptable); blades shall be completely symmetrical relative to their axle pivot point, presenting identical resistance to airflow and operation in either direction through the damper (blades that are non-symmetrical relative to their axle pivot point or utilize blade stops larger than 1/2 in. (13mm) are unacceptable); 1/2 in. (13mm) dia. plated steel axles turning in synthetic (acetal) sleeve bearings; TPE blade seals; flexible stainless steel jamb seals; and external (out of the airstream) blade-to-blade linkage.
  
7. [Outside air] [Return air] opening[s] shall be provided without a damper.]



- B. [Economizer section shall be provided with [end] [top] [bottom] [left] [right] [internal] [no] outside air opening, [end] [top] [bottom] [left] [right] [internal] [no] return air opening and [end] [top] [bottom] [left] [right] [internal] [no] exhaust air opening.
1. [Outside air] [Return air] [Exhaust air] damper[s] shall be low leak, hollow core galvanized steel airfoil blades, fully gasketed and have continuous vinyl seals between damper blades in a galvanized steel frame. Dampers shall have stainless steel jamb seals along end of dampers. Linkage and ABS plastic end caps shall be provided when return and outside air dampers sized for full airflow. Return and outside air dampers of different sizes or very large dampers and exhaust dampers must be driven separately. Damper Leakage: Leakage rate shall be less than two tenths of one percent leakage at 2 inches static pressure differential. Leakage rate tested in accordance with AMCA Standard 500.
  2. [Outside air] [Return air] [Exhaust air] damper[s] shall be Tamco 9000, [parallel] [opposed] blade, thermally insulated control damper. Return, outside, and exhaust air dampers must be driven separately.
    - a. Extruded aluminum (6063-T5) damper frame is not less than 0.080" (2.03 mm) in thickness. Damper frame is 4" (101.6 mm) deep × 1" (25.4 mm), with mounting flanges on both sides of frame.
    - b. Blades are extruded aluminum (6063-T5) airfoil profiles, internally insulated with expanded polyurethane foam and thermally broken. Complete blade has an insulating factor of R-2.29 and a temperature index of 55 (tested to AAMA 1502.7 Test Method).
    - c. Blade seals are extruded EPDM. Frame seals are extruded silicone. Seals are secured in an integral slot within the aluminum extrusions. Blade and frame seals are mechanically fastened to prevent shrinkage and movement over the life of the damper.
    - d. Bearings are composed of a Celcon inner bearing (fixed around a 7/16" (11.11 mm) aluminum hexagon blade pivot pin) rotating within a polycarbonate outer bearing inserted in the frame. This eliminates action between metal-to-metal or metal-to-plastic riding surfaces.
    - e. Adjustable 7/16" (11.11 mm) hexagonal drive rod, U-bolt fastener, and hexagonal retaining nuts are zinc-plated steel. These provide a positive connection to blades and linkage.
    - f. Aluminum and corrosion-resistant zinc-plated steel linkage hardware is installed in the frame side, complete with cup-point trunnion screws for a slip-proof grip.
    - g. Dampers are designed for operation in temperatures ranging from -40°F (-40°C) to 212°F (100°C).
  3. [Outside air] [Return air] [Exhaust air] damper[s] shall be Tamco 1000, [parallel] [opposed] blade, low leak airfoil control damper. Return, outside, and exhaust air dampers must be driven separately.
    - a. Extruded aluminum (6063-T5) damper frame is not less than 0.080" (2.03 mm) in thickness. Damper frame is 4" (101.6 mm) deep × 1" (25.4 mm), with mounting flanges on both sides of frame.
    - b. Blades are extruded aluminum (6063-T5) airfoil profiles.
    - c. Blade seals are extruded EPDM. Frame seals are extruded silicone. Seals are secured in an integral slot within the aluminum extrusions. Blade and frame seals are mechanically fastened to prevent shrinkage and movement over the life of the damper.
    - d. Bearings are composed of a Celcon inner bearing (fixed around a 7/16" (11.11 mm) aluminum hexagon blade pivot pin) rotating within a polycarbonate outer bearing inserted in the frame. This eliminates action between metal-to-metal or metal-to-plastic riding surfaces.
    - e. Adjustable 7/16" (11.11 mm) hexagonal drive rod, U-bolt fastener, and hexagonal retaining nuts are zinc-plated steel. These provide a positive connection to blades and linkage.
    - f. Aluminum and corrosion-resistant zinc-plated steel linkage hardware is installed in the frame side, complete with cup-point trunnion screws for a slip-proof grip.
    - g. Dampers are designed for operation in temperatures ranging from -40°F (-40°C) to 212°F (100°C).
    - h. Leakage Class 1A at 1 in w.g. (0.25 kPa) static pressure differential. Standard air leakage data is certified under the AMCA Certified Ratings Program.
    - i. Dampers are custom made to required size, without blanking off free area.
  - h. Leakage Class 1A at 1 in w.g. (0.25 kPa) static pressure differential. Standard air leakage data is certified under the AMCA Certified Ratings Program.
  - i. Dampers are custom made to required size, without blanking off free area.

4. [Outside air] [Return air] [Exhaust air] damper[s] shall be Ruskin CD60, [parallel] [opposed] blade, low leak airfoil control damper. Return, outside, and exhaust air dampers must be driven separately.
  - a. Control dampers shall be produced in an ISO9001 certified factory.
  - b. Frame shall be one-piece uniframe construction of 16 ga. (1.6) galvanized steel roll formed hat channel structurally equivalent to a minimum 13 ga. (2.4) frame.
  - c. Blades shall be 14 ga. (2.0) equivalent galvanized steel, roll-formed airfoil type for low pressure drop and low noise generation.
  - d. Blade edge seals shall be Ruskiprene™ TPV type or equivalent mechanically locked into the blade edge. Adhesive or clip-on type seals are unacceptable.
  - e. Jamb seals shall be stainless steel chambered compression type to prevent leakage between blade end and damper frame. Blade end overlapping frame is unacceptable.
  - f. Multiple section dampers must have factory installed jackshafts unless clearly eliminated by engineer.
  - g. Bearings shall be 304 stainless steel, oil impregnated, and self-lubricating sleeve type with a 450 pound (204 kg) minimum radial crush load. Bearings shall turn in extruded holes in the damper frame.
  - h. Axles shall be hexagonal positively locked into the damper blade.
  - i. Linkage shall be concealed out of airstream, within the damper frame to reduce pressure drop and noise.
  - j. Temperature limits shall be -72°(-58°C) to +275°F (+135°C).
  - k. Damper shall be tested and licensed in accordance with AMCA 511 for Air Performance and Air Leakage.
  - l. Damper widths from 12" to 60" (305 to 1524) wide shall not leak any greater than 3 cfm/sq.ft. at 1" w.g. (15.2 l/s-m<sup>2</sup> at .25 kPa).
5. [Outside air] [Return air] [Exhaust air] damper[s] shall be Greenheck VCD33 [stainless steel] [galvanized], [parallel] [opposed] blade, low leak airfoil control damper. Return, outside, and exhaust air dampers must be driven separately.
  - a. Dampers shall consist of: a 16 ga. (1.5mm) [galvanized steel] [304 stainless steel] channel frame with 5 in. (127mm) depth; airfoil shaped, [galvanized steel] [304 stainless steel] double skin construction blades (14 ga. [2mm] equivalent thickness); blades shall be completely symmetrical relative to their axle pivot point, presenting identical resistance to airflow in either direction or pressure on either side of the damper; 1/2 in. (6mm) dia. plated steel axles turning in synthetic (acetal) sleeve bearings; TPE blade seals for 200°F (93°C) maximum temperature; flexible stainless steel jamb seals; and external (out of the airstream) blade-to-blade linkage.
6. [Outside air] [Return air] [Exhaust air] damper[s] shall be Greenheck VCD43 aluminum, [parallel] [opposed] blade, low leak airfoil control damper. Return, outside, and exhaust air dampers must be driven separately.
  - a. Dampers shall consist of: heavy gauge aluminum frame (0.125 in. [3.2mm] thick) with 5 in. (127mm) depth formed into a structural hat channel shape; airfoil shaped, extruded aluminum blades (0.063 in. [1.6mm] thick) with metal blade to blade overlap (seal to seal only contact is not acceptable); blades shall be completely symmetrical relative to their axle pivot point, presenting identical resistance to airflow and operation in either direction through the damper (blades that are non-symmetrical relative to their axle pivot point or utilize blade stops larger than 1/2 in. (13mm) are unacceptable); 1/2 in. (13mm) dia. plated steel axles turning in synthetic (acetal) sleeve bearings; TPE blade seals; flexible stainless steel jamb seals; and external (out of the airstream) blade-to-blade linkage.
7. [Outside air] [Return air] [Exhaust air] opening[s] shall be provided without a damper.]
  - C. [Access section shall provide access between components shall be a minimum of [16" (406mm)] [24" (610mm)] [30" (762mm)] [36" (914mm)] [42" (1067mm)] [48" (1219mm)] [54" (1372mm)] deep. Access doors of galvanized steel for flush mounting, with gasket, latch and full size (minimum of 4.5") handle assembly. [Provide stainless steel drip pan in access section.] [Floor shall be lined with .125-inch aluminum tread plate to accommodate walk-in weight of service technician.]
  - D. [Diffuser section shall be mounted on leaving side of supply fan section providing uniform air distribution across downstream components. Perforated diffuser plate shall be secured over blast area of fan to disperse airflow.]
  - E. [Blender / air mixer section to provide proper

air mixing and distribution of the outside and return airstreams. Proper spacing provided in the direction of airflow as recommended by the blender manufacturer (Blender Products or Kees).]

- F. [Sound attenuator section(s) shall be provided by the air handling unit manufacturer as an integral section of the unit to attenuate fan noise at the source. Provide acoustic performance and air pressure drop as scheduled. Silencer acoustic insulation shall be covered with perforated sheet metal. [Provide [mylar] [tedlar] [fiberglass cloth] liner between perforated sheet metal and acoustic insulation].
- G. [Manual section shall be provided by the air handling unit manufacturer as an integral section of the unit for field installation of special components. Section length to be determined by component supplier.]
- H. [[Inlet] [Discharge] plenum section shall be provided as the [first] [last] section in the direction of airflow. The plenum shall provide single or multiple [top] [end] [bottom] openings.]
- I. [Face and bypass section shall be provided to modulate airflow through and around heat transfer coils. Dampers shall be an integral part of the unit assembly. [Internal face and bypass shall be contained in the standard cabinet height] [External face and bypass arrangement shall be provided with factory provided bypass duct of same cabinet construction as the remainder of the unit. Field installed bypass ducts are not acceptable]. Blank-off and division sheets, internal linkage, access [panel] [doors] installed by unit manufacturer. Face and bypass dampers shall be of low leak design, opposed blade, with vinyl bulb edging and stainless steel edge seals, galvanized steel frame and axles in self-lubricating nylon bearings.]
- J. [ Humidifier Steam Dispersion Panel (Short Absorption Manifold, SAM-e)
  - 1. Short Absorption Manifold designed for atmospheric steam humidifiers or pressurized steam from a boiler, to directly inject the steam into ducted air for humidification. Performance shall be factory selected based on scheduled criteria.
  - 2. Absorption distance characteristic shall prevent water accumulation on any surfaces beyond the drain pan downstream of the steam dispersion panel.
  - 3. Steam dispersion panel consisting of a (one) horizontal stainless steel header supplying steam to a bank of closely spaced vertical tubes, as necessary to meet absorption distance requirements, and to reduce condensation losses.
  - 4. Dual header systems creating unnecessary condensation or systems needing to be installed on a partition or requiring blank off plates are not acceptable.
  - 5. Header design shall be round tube to minimize pressure drop. Square headers are not acceptable.
  - 6. Steam inlet and condensate return located on the same side and at the bottom of the header to allow single point entry and floor mounting.
  - 7. Headers shall be 304 stainless steel construction.
  - 8. Vertical 304 stainless steel distribution tubes shall be provided to promote condensate evacuation. Horizontal distributor tubes are not acceptable.
  - 9. Distribution tubes shall include threaded standoffs for trouble free attachment to factory supplied support bracket.
  - 10. Stainless steel nozzle inserts ensure condensate free steam is discharged from the center of the distribution tubes. Systems without nozzle inserts, or other than stainless steel, are not acceptable.
  - 11. Stainless steel nozzle inserts shall have metered orifices, sized to provide even distribution of the discharged steam, spaced for optimum steam absorption.
  - 12. Comply with AHRI 640, "Standard for Commercial and Industrial Humidifiers."]

**K. [Energy Recovery]**

1. [Fixed Plate air-to-air heat exchanger shall be constructed of rigid thermally bonded plates separated by aluminum spacers. Exposed folded or crimped edges are not acceptable. The exchanger corrugations shall be bonded to the flat plates with a thermal adhesive and be capable of withstanding pressure differentials of up to 15" w.g. without deforming air passages. The entire heat transfer surface shall be capable of visible inspection and cleaning. Factory personnel shall calculate fixed plate temperature and pressure drop performance.]
2. [Flat plate energy recovery device heat transfer surface shall be formed aluminum plates with enhanced surface corrugation for increased performance. Exchanger frame profiles shall be all aluminum with sheet metal end plates. Exchanger shall be capable of withstanding a pressure difference between airflows of up to 7.2" w.g. without deforming air passages. Standard cell construction shall have a maximum cross contamination between airflows of 0.1% of total airflow. The entire cell shall be capable of being visibly inspected and cleaned as required.]
3. [The enthalpy plate exchanger shall transfer both sensible and latent energy between the incoming fresh air stream and the exhaust stale air stream. The ERV core shall be in either a cross-flow or counter cross-flow orientation and have no moving parts. The ERV core shall be certified by AHRI under its Standard 1060 for Energy Recovery Ventilators. Products not currently AHRI certified will not be accepted. The fresh air stream must have complete separation from the stale air stream to prevent cross contamination. The ERV core shall have a 0% Exhaust Air Transport Ratio as tested to AHRI 1060-2005 (EATR) to prevent cross-over of gases, contaminants or odors. The ERV core shall inhibit mold and bacteria growth as tested to Standard AATCC 30 with 100% surface inhibition on the Aspergillus mold test and 100% surface inhibition the Kirby Bauer Staphylococcus bacteria test. The ERV core must be able to tolerate freezing temperatures of -30C and not have an increase in EATR or decrease in performance after being frozen. The ERV core must be able to tolerate high temperatures of +60C and not have an increase in EATR or decrease in performance at these elevated temperatures. The ERV core must be water washable to remove dust and contaminants. The ERV core must be flame proof and comply with UL 723 with a flame spread index that shall not be over 25 and a smoke index that shall not be over 50. The ERV shall have a frame consisting of 5052 series aluminum end plates and aluminum alloy 6063 extruded side rails.]

4. [Energy recovery wheel shall be constructed of corrugated synthetic fibrous media, with a desiccant intimately bound and uniformly and permanently dispersed throughout the matrix structure of the media. Rotors with desiccants coated bonded, or synthesized onto the media are not acceptable due to delaminating or erosion of the desiccant material. Media shall be synthetic to provide corrosion resistance and resistance against attack from laboratory chemicals present in pharmaceutical, hospital, etc. environments as well as attack from external outdoor air conditions. Coated aluminum is not acceptable. Face flatness of the wheel shall be maximized in order to minimize wear on inner seal surfaces and to minimize cross leakage. Rotor shall be constructed of alternating layers of flat and corrugated media. Wheel layers should be uniform in construction forming uniform aperture sizes for airflow. Wheel construction shall be fluted or formed honeycomb geometry so as to eliminate internal wheel bypass. Wheel layers that can be separated or spread apart by airflow are unacceptable due to the possibility of channeling and performance degradation. The minimum acceptable performance shall be as specified in the unit schedule.

**Desiccant Material:** The desiccant material shall be a molecular sieve, and specifically a 4A or smaller molecular sieve to minimize cross contamination.

**Wheel Media Support System:** The wheel frames shall consist of evenly spaced steel spokes, galvanized steel outer band and rigid center hub. The wheel construction should allow for post fabrication wheel alignment.

**Wheel Seals:** The wheel seals shall be full contact nylon brush seals or equivalent. Seals should be easily adjustable.

**Wheel cassette:** Cassettes shall be fabricated of heavy duty reinforced galvanized steel or welded structural box tubing. [Cassettes shall have a built in adjustable purge section minimizing cross contamination of supply air.] Bearings shall be inboard, zero maintenance, permanently sealed roller bearings, or alternatively, external flanged or pillow block bearings.

Drive systems shall consist of fractional horsepower AC drive motors with multi-link drive belts.

[Bypass dampers shall be furnished.]

**Certification:** The wheel shall be AHRI certified by the energy recovery wheel supplier to AHRI Standard 1060 and must bear the AHRI certification stamp. Private independent testing performed "in accordance with" various standards is not a substitute for AHRI certification and shall not be accepted. The wheel shall be listed or recognized by UL or equivalent.]

5. [Energy recovery wheel heat exchanger shall be constructed of alternate layers of corrugated and flat aluminum sheet material. Both sides of the exchanger shall be completely smooth with less than 0.005" variation between alternate layers to allow for optimum sealing surface for brush seals. The rotor shall have smooth air channels to ensure laminar airflow for low-pressure drops. Dry particles up to 900 microns shall pass freely through the rotor without clogging the media. The rotor media shall be capable of being cleaned with low temperature steam without degrading unit performance. The rotor media must be made of aluminum that is coated to prohibit corrosion. All surfaces shall be coated with a non-migrating absorbent specifically developed for the selective transfer of water vapor.

Performance shall be as scheduled and verified by manufacturer. Assuming equal sensible and latent recovery effectiveness shall not derive performance.

The rotor housing shall be constructed using a heavy-duty extruded and anodized aluminum tube frame (rotors less than 42" shall have a heavy duty galvanized frame without insulation) with double wall galvanized sheet metal panels with fiberglass insulation. Adjustable brush seals must be provided along the periphery of the rotor and between the inlet and outlet air passages to effectively prevent air leakage and cross-contamination between airflows. Total airflow between air streams from leakage and purge shall be less than 10% at 2.5"w.g. differential pressure between airflows. Rotor and casing shall be reinforced to prevent deflection from differential pressures to less than 0.03 inches. All rotors shall be mounted on sealed permanently lubricated spherical bearings. All rotors over 80" in diameter must have flanged or pillow block bearings that can be serviced or replaced without removal of the rotor from the case.

[The unit must be provided with a factory set, field adjustable purge sector designed to limit cross contamination at qualified appropriate design conditions to less than 0.04 percent of the exhaust air stream concentration. Independent laboratory evaluations must indicate purge sector configurations, rotor construction, gasses, air pressure differentials, rotor speeds and other phenomena that constitute "appropriate design conditions" required to limit cross-contamination and air leakage.]

The rotor drive system shall consist of a self-adjusting belt around the rotor perimeter driven by an AC motor with gear reduction. The variable speed drive shall be specifically designed for heat wheel applications and include: an AC inverter, soft start/stop, rotation detection w/alarm contacts, automatic self-cleaning jog cycle, and self testing capability. The speed controller shall be capable of accepting a potentiometer, VDC, or mA control signal.

[The temperature control system shall consist of an integral control panel with remote temperature sensors mounted in each of the four air streams to monitor exchanger performance. The control shall modulate rotor speed to (1) prevent frost build-up, (2) reduce heat recovery for economizer mode, and (3) switch to maximum heat recovery when outdoor temperature is higher than indoor temperature. A digital display keypad for monitoring temperatures and changing set points shall be included.]

[Bypass dampers shall be furnished.]

AHRI Certification: Sensible and latent recovery effectiveness must be clearly certified by the energy recovery wheel supplier through AHRI in accordance with AHRI Standard 1060.]



## **2.12 DAMPERS**

- A. Damper Leakage: Leakage rate shall be less than two tenths of one percent leakage at 2 inches static pressure differential. Leakage rate tested in accordance with AMCA Standard 500.
- B. [Multi-Zone Dampers: Zone dampers for use with [2 deck] or [3 deck], vertical or horizontal system. Factory mounted in casing of galvanized steel blades [with vinyl bulb edging]. Low leak dampers with bronze end and side seals, locked in position to common shaft with rotation angles of 90°, requiring one actuator per zone. Damper rods rotate in nylon bushings.]

## **2.13 CONTROLS**

- A. [Manufacturer shall furnish and mount 24V control components that shall be terminated at a sealed junction box on the unit exterior of each section in which the component is mounted. The components include low temperature limits (freeze-stats), air proving switches, discharge air, return air, exhaust air temperature sensors, and CO<sub>2</sub> sensors as specified in the control schedule. The control components must be compatible with [Alerton] [Automated Logic] [Honeywell] [Invensys] [Johnson Controls] [Siemens] as indicated in the control specification. [The manufacturer shall furnish and mount [Belimo] [Johnson Controls] actuators for all dampers.]

# **PART 3: EXECUTION**

## **3.01 INSTALLATION**

- A. Install in accordance with manufacturer's Installation & Maintenance instructions.

## **3.02 ENVIRONMENTAL REQUIREMENTS**

- A. Do not operate units for any purpose, temporary or permanent, until ductwork is clean, filters are in place, bearings lubricated, and fan has been test run under observation.



### ***Daikin Applied Training and Development***

Now that you have made an investment in modern, efficient Daikin equipment, its care should be a high priority. For training information on all Daikin HVAC products, please visit us at [www.DaikinApplied.com](http://www.DaikinApplied.com) and click on Training, or call 540-248-9646 and ask for the Training Department.

### ***Warranty***

All Daikin equipment is sold pursuant to its standard terms and conditions of sale, including Limited Product Warranty. Consult your local Daikin Representative for warranty details. To find your local Daikin Representative, go to [www.DaikinApplied.com](http://www.DaikinApplied.com).

### ***Aftermarket Services***

To find your local parts office, visit [www.DaikinApplied.com](http://www.DaikinApplied.com) or call 800-37PARTS (800-377-2787). To find your local service office, visit [www.DaikinApplied.com](http://www.DaikinApplied.com) or call 800-432-1342.

This document contains the most current product information as of this printing. For the most up-to-date product information, please go to [www.DaikinApplied.com](http://www.DaikinApplied.com).

Products manufactured in an ISO Certified Facility.