



Catalog 570-12

Skyline[®] Outdoor Air Handler
Sizes 003 through 090



Nomenclature and Certification	3	Selecting Coils	21
AHRI Certification	3	Selecting Accessories	22
IBC Certification (optional)	3	Selecting Fans	22
Agency Listed	3	Quick Select Tables	23
The Skyline Air Handler Advantage	4	Application Considerations	25
Introduction	6	Installation Flexibility	25
Quality	6	Unit Location	25
Flexibility	6	Curb Installation	25
Cabinet Construction	6	Ductwork	25
Access and Serviceability	8	Piping and Drain Pan Traps	26
Seismic Design Considerations	8	Coil Freeze Protection	26
Daikin SelectTools Software Selection Program	9	Vibration Isolation	26
Skyline's Unique Standard Features	10	Sound	26
Skyline Customized Options	12	Filters	26
Component Types	14	Air Supply Systems and Fan Laws	27
Fans	14	Fan and Motor Heat	28
Coils	16	Variable Air Volume	28
Filters	17	Engineering and Physical Data	29
Gas Heat	18	Component and Section Weights	41
Access	19	Fan Data	43
Mixing Boxes and Economizers	19	Coil Data	45
Face and Bypass Dampers	19	Side Load Filter Data	47
Blenders/Air Mixers	20	Dimensional Data	49
Attenuators	20	Electrical Data	80
Air Handler Selection	21	Supply Power Wiring	80
Energy Recovery	21	Engineering Guide Specification	81

Nomenclature

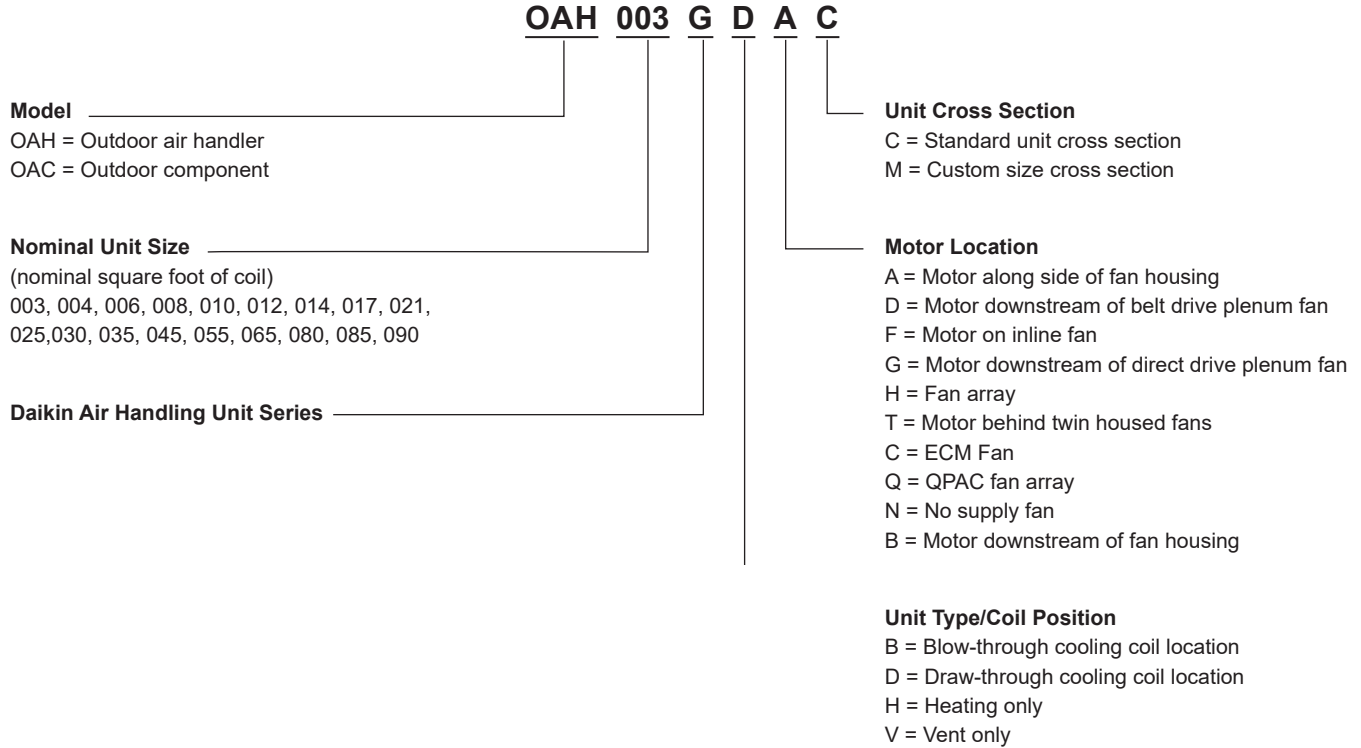

AHRI Certification



Certified in accordance with the forced circulation air cooling and air heating coils certification program, which is based on AHRI Standard 410.



Standard and custom size units certified in accordance with the central station air handling units certification program, which is based on AHRI Standard 430.

Labeled Skyline units are tested and listed by ETL in accordance with UL 1995, Standard for Safety Heating and Cooling Equipment, and thereby fully comply with NFPA 90A material requirements.

IBC Certification (optional)

Seismic certification per applicable buildings codes tested and analyzed in accordance with:

**IBCO AC156
ASCE-7**

**IBC 2000, 2003,
2009, 2012
NFPA 5000**

VMC Seismic Consulting Group:

Serial Number 39928V

Available upon request.

OSHPD Pre-Approval (optional): OSP-0325-10

Miami-Dade County approval NOA No. 13-0206

Agency Listed



Intertek

**MEA
342-99-E**

**All standard units
All custom size units
All Canadian units**

Flexibility	
Skyline's unique design	What it can do for you
Custom-modular platform	Allows customizing of the system with a wide selection of components and sizes.
Variable Dimensioning™ design	Allows cabinet to be sized in two-inch increments (height and width) to meet installation or aesthetic requirements.
Multiple coil face areas per model size	Allows you to closely match performance and capacity requirements.
Multiple customized component options for fans, coils, filters and cabinet construction	Allows optimum selections for cost, energy efficiency, performance, indoor air quality, and low noise.
Optional factory-supplied roof curb with separate pipe chase in variable heights (16", 20", 24" or 30")	Designed specifically for your unit and your height requirements.
Indoor Air Quality	
Skyline's unique design	What it can do for you
Low-leakage cabinet construction Standard Cabinet: less than 0.5 CFM/ft ² of cabinetry at design static up to +5/-6" w.c. High Pressure Cabinet: less than Class 6 leakage or 1% supply air volume at design static up to +/-8" w.c.	Minimizes air leakage, noise and unfiltered air.
Double sloped stainless steel drain pan	Inhibits bacterial growth; eliminates standing water that can support bacteria.
Double-wall, foam injected construction	Smooth interior surfaces reduce potential for accumulating dirt and microbial growth. Eliminates fiberglass fibers eroding into the air stream.
Multiple filter types (flat, angular, bag and cartridge) with side-load and front-load capabilities	Gives full range of filter efficiencies, final filter arrangements, and filter section depth flexibility.
Hinged access doors with full-grip handles or easy-to-remove access panels	Allows for easy inspection and cleaning of drain pans; promotes regular inspections.
Patented gasketed frame channels	Minimizes direct exposure of metal to metal in cabinet framework to reduce cold bridging and condensate collection; lowers operating costs.
Patented splice collar	Prevents unfiltered, unconditioned air from entering the system. Allows for leak-resistant section to section joining in the field.

Operating Efficiency	
Skyline's unique design	What it can do for you
Low air-leakage cabinet design, all inside and outside panel penetrations are sealed	Increases operating efficiency; reduces energy loss and operating costs.
Patented gasketed frame channels	Minimizes direct exposure of metal to metal in cabinet framework to reduce cold bridging and condensate collection; lowers operating costs.
Fan selection options (housed forward curve or airfoil, belt-drive or direct-drive plenum, inline and twin fans, fan array, ECM fans)	Results in lowest possible BHP requirements.
Patented UltraSeal™ low-leak dampers	Maximizes operating efficiency; reduces operating cost.
Easy, Low Cost Installation	
Skyline's unique design	What it can do for you
Ships assembled or in sections (if required) with optional heavy duty base rail and lifting lugs on all four corners	Facilitates easy rigging and installation.
Patented section splicing (if required)	Saves installation time; creates an airtight environment.
Optional factory supplied roof curb with separate pipe chase in variable heights (16", 20", 24" or 30")	Designed to match custom modular flexibility of your unit and your height requirements.
Variable depth piping vestibules	Allows you to select vestibule depth to match piping requirements.
Coil connections extend through cabinet with gasketed airseal, external drains and vents	Allows easy connection in piping vestibule to save time and cost; preserves air-tight environment.
Fan system factory tested and balanced	Saves time during installation and promotes proper operation.
Easy Maintenance and Serviceability	
Skyline's unique design	What it can do for you
Direct-drive plenum fans	No fan bearings, belts or drives to replace or maintain
Extended fan bearing lube lines	Makes lubricating fan system easier.
Extended coil drain connections	Reduces coil venting time; helps coil condensate drain completely.
Hinged access doors with full grip handles or easy-to-remove access panels in a wide range of section depths	Makes it fast and easy to clean and inspect drain pan, clean or remove coil, clean interior.
Durable, Weathertight Cabinet for Long Life	
Skyline's Unique Design	What It Does For You
Cross-broken roofcap and "C" cap over seam joints	Eliminates standing water and provides a weathertight seal.
Drip shield on all sides and over doors	Directs water away from cabinet.
Pre-painted cabinetry (galvanized optional)	Resists corrosion for long life.
Intake and exhaust hoods	Direct rain or snow away from required openings.
Galvanized or stainless steel liners	Helps extend insulation life and allows easy cleaning.

Quality

Daikin air handling equipment has been respected and regarded as high quality for nearly 60 years. Daikin has taken a major step in redefining the outdoor air handler with the Skyline air handler. Demands for improved indoor air quality, low sound, and high operating efficiency require a better product for today's air handler market. The Daikin Skyline air handler is designed to meet or exceed these demands.

In addition to our patented construction, Daikin Skyline outdoor air handlers feature a durable, weathertight cabinet that promotes long life of your air handler. Units ship completely assembled or by section (if necessary) with a curb-ready base rail and heavy-duty lifting lugs on all four corners to facilitate easy rigging and installation. An optional factory-supplied roof curb, specifically designed for your unit, is available in variable heights (from 16" to 30") to further simplify installation.

Flexibility

By virtue of its unique frame design, the Daikin Skyline outdoor air handler offers tremendous flexibility. This flexibility is reflected in our unique Variable Dimensioning™ feature that allows units to be sized in two-inch increments (height and width) to meet your requirements. Numerous section and component options, and the ability to arrange components in whatever arrangement is required, allow Skyline air handlers to be customized to the requirements of each job, without expensive modifications in the field.

The Daikin Skyline unit can be equipped with a unitized, single piece base. This allows for a single lift, greatly reducing the time a crane has to be on site. A time spent piecing individual section together is also minimized. This configuration can be ordered with a factory manufactured, field installed piping vestibule. This allows for wider units to be shipped on a standard flat-bed truck.

For those projects the need multiple lifts, the Daikin Skyline unit can be broken into sections. This allows the lift to be completed with a smaller crane or to minimize the weight on a long boom crane. This configuration comes equipped with a factory manufactured and installed piping vestibule.

Cabinet Construction

Daikin air handler cabinetry consists of a box-type frame channel, easy-to-remove panels or hinged access doors, and a standard base rail or an optional integral curb-ready base with heavy-duty lifting lugs. Channel material is G60 painted galvanized steel (optional—unpainted G90 galvanized steel) with neoprene gasketing on all flanges to minimize leakage. Gasketing is also factory applied at all contact surfaces between interior and exterior metal components to minimize thermal bridging. See [Figure 1](#).

Panels are constructed of pre-painted steel and are secured to the unit with fasteners that can be easily removed to access the unit interior. Optional doors with full grip handles are also available.

Figure 1: Patented Gasketed Frame Channel

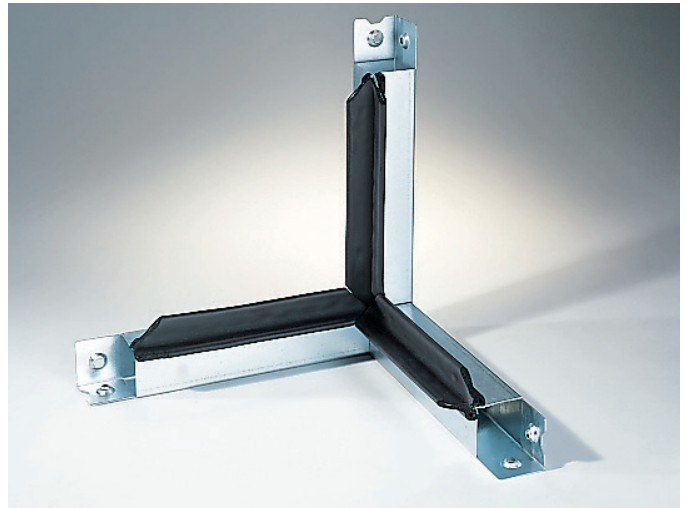

Standard Cabinet

This unique cabinet design results in air tight, thermally efficient units, which translates into energy savings over the life of the unit. Skyline air handlers are capable of casing leakage rates that shall not exceed 0.50 CFM per square foot of casing surface area a design static pressure up to a maximum of +5" w.c. in positive pressure sections and -6" w.c. in negative pressure sections.

High Pressure Cabinet

The high pressure air handler construction utilizes laser welding technology to provide stronger frame channels and new gaskets to reduce the standard leakage rate to a casing leakage rate that shall not exceed ASHRAE 111 Class 6 or be no more than 1% of the supply air volume at design static pressure up to a maximum of +8" w.c. in positive pressure sections and -8" w.c. in negative pressure sections, where casing leakage (CFM/100 ft² of casing surface area) = $C_L \times P^{0.65}$. The high pressure air handler construction maintains the unique flexibility, ease of installation and serviceability that Skyline has had for years while providing best-in-class air sealing.

ASHRAE 111 is the test standard to test duct leakage. The standard uses a class system to indicate relative leakage rates. These class levels are dependent on static pressure and surface area. The formula for leak class is:

$$C_L = \frac{F}{P^{0.65}}$$

where $F = \frac{\text{Leakage in CFM}}{100 \text{ ft}^2 \text{ Cabinet Surface Area}}$ and $P = \text{Static pressure in inches w.c.}$

A standard base rail or a heavy-duty, curb-ready base rail with integral lifting lugs on all four corners facilitates easy rigging for installation. If it is necessary to ship a unit in multiple sections, each section is equipped with a base rail and lifting lugs. A patented splice joint helps guide sections together for a tight fit, saving additional time and money on installation. Splice joints are also fully insulated at the factory.

Figure 2: Curb-Ready Base Rail and Lifting Lugs



Skyline air handlers are equipped with several features to provide durability against harsh outdoor conditions. Cross-broken roofcaps eliminate standing water on the unit and a "C" cap over seam joints provides a watertight seal. The roof cap extends over optional piping vestibules without any seams. Drip shield on all sides and over doors, as well as intake and exhaust hoods with screens, direct water away from the unit and required openings. An insulated, double-walled piping vestibule encloses all piping and control valves within the unit cabinet and can be selected in varying depths to meet your piping requirements.

Figure 3: Integral Piping Vestibule



Access and Serviceability

Equipment must be designed to perform efficiently and withstand the wear and tear of everyday use. It also must be designed to provide easy access to interior components for routine maintenance and service to maintain peak performance. The patented frame channels and easy-to-remove panels or hinged access doors of the Skyline outdoor air handler cabinet provide complete access to the unit interior and components.

Figure 4: Hinged Access Doors



Seismic Design Considerations

Strict design, testing, and certification requirements for heating, ventilating, and air-conditioning equipment are clearly defined in the International Building Code, versions 2000 and 2003, for designated structures in earthquake-prone locations.

The goals of these requirements are to maintain systems to protect the public from hazard and maintain essential public services immediately after an earthquake. With the widespread adoption of the IBC throughout the U.S., it is important to understand its requirements and their impact on your specific building, and where you can turn for equipment to satisfy those requirements. Tested and certified compliant with the seismic provisions of the IBC, Daikin Skyline air handlers also comply with the construction requirements of NFPA 5000.

For use by the building official and design professional, the IBC has defined Seismic Use Group designations based on building use along with specific criteria for determining the Seismic Design Category of the building and the applicability of seismic design criteria to the building's mechanical equipment. Provide this information to your local Daikin Sales Representative so the proper modifications can be made to the air handler and have a compliance label affixed to the product so all IBC requirements in this regard are complied with. For additional information, Daikin has several published articles explaining in detail IBC seismic requirements. Go to www.DaikinApplied.com or contact your local Daikin sales representative to obtain these articles.

Daikin also has construction pre-certified for California's strict Office of Statewide Health Planning and Development (OSHPD) requirements. The OSHPD pre-approval shows that Daikin has already completed testing to allow engineers to specify, contractors to install, and owners to operate equipment that will still work after a seismic event.

Daikin SelectTools Software Selection Program

Because the Daikin Skyline air handler is so flexible and has so many different component types, there virtually are an infinite number of possible unit arrangements. To help the customer easily define their product requirements, Daikin provides a user-friendly software selection program, called Daikin SelectTools. This program configures and sizes both standard and custom units. Components can be selected in minutes.

This Windows® based program leads the user through the selection process by prompting for pertinent input data for all components required. Component sections are selected by placing them on a configuration screen. Once the unit layout is defined, the options and accessories are identified. The program gives immediate feedback regarding fan and coil selection, offering a choice of many different options based on the performance inputs. Once final component selections have been made, the program provides all output needed for specification and submittal purposes, including fan curves, coil performance psychometric charts, weights, dimensional drawings, and a unit specification.

Daikin SelectTools is a comprehensive, efficient and user-friendly software selection program.

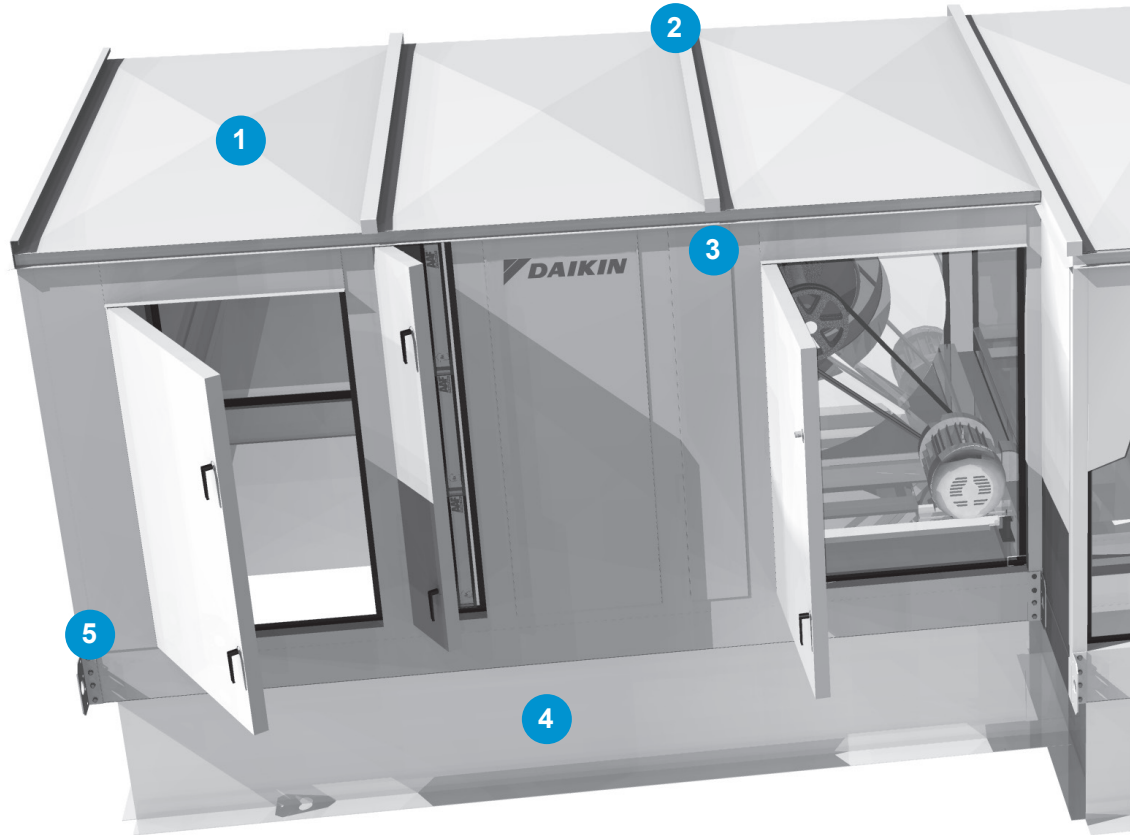

1 Durable, Weathertight Cabinet

- Cross-broken roofcaps eliminate standing water.
- Standing “C” cap over seam joints provides a watertight seal.
- Drip shield on all sides and over doors.
- Pre-painted cabinetry (galvanized optional).
- Galvanized or stainless steel liners.
- Rigid, thermal efficient (R-13) injected-foam panels are strong and lightweight



2 Custom Modular Design

- Allows custom selection and configuration of components to meet performance requirements.

3 Double-wall Construction

- Reduces dirt accumulation.
- Facilitates cleaning.
- Protects insulation.
- Improves IAQ.

4 Factory Supplied Roof Curb (Optional)

- Designed specifically to match custom modular flexibility of your unit.
- Variable heights of 16", 20", 24", or 30" to meet your requirements.

5 Heavy Duty Base Rail

- Curb-ready design forms a watertight seal on roof curb assembly (as shown) or standard base rail (4" to 12").
- Lifting lugs on all four corners of each shipping section to facilitate easy rigging.
- Unitized single ship option to minimize shipping costs



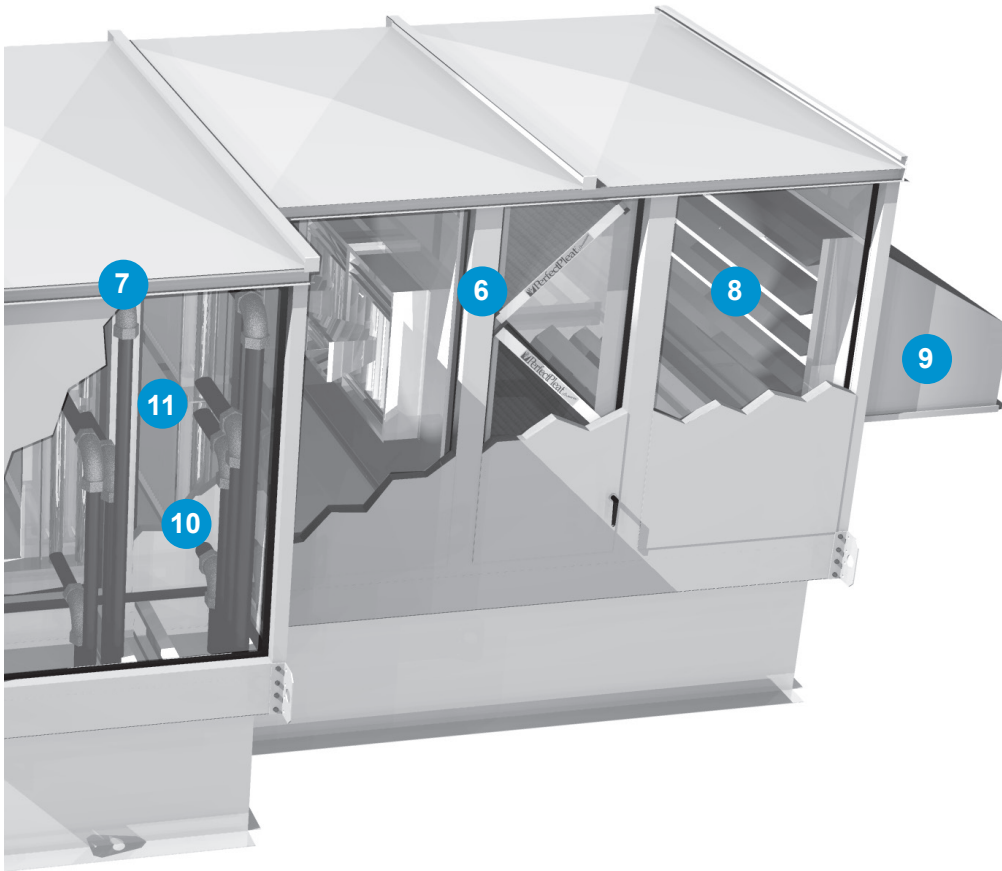

6 Gasketed Frame Channel Construction

- Eliminates metal-to-metal contact between paneling and framework.
- Minimizes condensate and corrosion.
- Promotes long life.

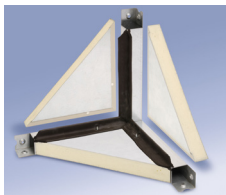

7 Piping Vestibule (Optional)

- Encloses piping connections within unit cabinet.
- Variable depths to meet your piping requirements (18", 24", 30").

8 Patented Ultraseal™ Low-leak Dampers

- Maximize operating efficiency.
- Reduce operating costs.



9 Damper Hoods (Optional) with Screens

- Direct rain, snow and debris away from required openings.

10 Visible Double-sloped Drain Pan

- Stainless steel drain pan to inhibit bacteria growth.
- Makes inspection and cleaning easier.
- Improves IAQ.



11 Extended Coil and Drain Connections

- Saves installation costs.
- Reduces maintenance time.

Use Daikin Skyline product platform to build the ideal outdoor air handler for your specific application. Customized options include:

- Variable Dimensioning™ design cabinet sizing on 2" increments (height and width)
- Multiple coil face areas per unit size
- Multiple section depths
- Multiple section, curb-ready base
- Single piece, unitized curb-ready base
- Variable height roof curbs (16", 20", 24" or 30") with separate pipe chase
- Variable depth piping vestibules (18", 24", 30")
- Various casing and drain pan materials
- Mixing boxes/economizers
- Sound attenuators
- Multiple blower options including housed airfoil, belt- or direct-drive plenum, dual plenum and fan array
- Filters (flat, angular, bag and cartridge) available in side load or front-loading configuration
- HEPA filters in final filter location
- Starters and inverters (VFDs)
- Disconnect switches
- Marine lights and receptacles
- Hinged access doors with full grip handles
- Manual selections to accommodate special components
- Humidifier manifold

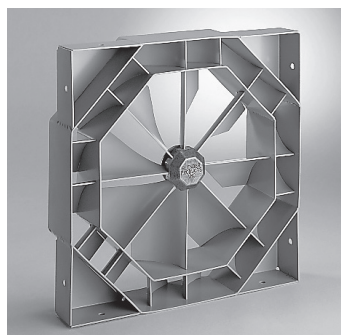
Fan Options

Blender/Air Mixer Options

Multiple Filter Options

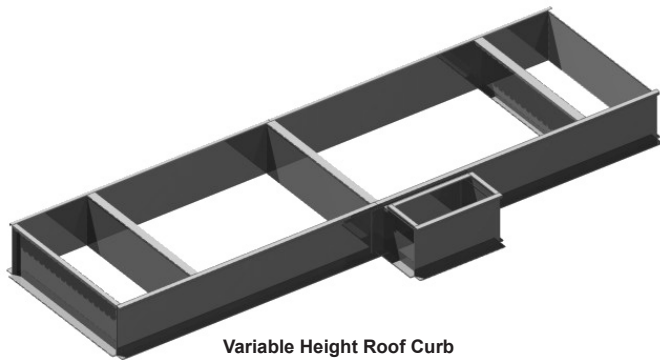
RETURN/ EXHAUST	ECONOMIZER	BLENDER	FILTER	F & BP DAMPER	COIL	ACCESS	HORIZONTAL COIL	SUPPLY FAN	DIFFUSER	COIL BLOW THRU	ACCESS	FILTER	ATTENUATOR PLENUM
PLENUM FAN	FC, AF FAN & TWIN FAN	2" & 4" ANGULAR	INTERNAL	HORIZ HEATING	LARGE	CLG. / HTG. COMBINATION	FC, AF FAN, & TWIN FAN		HORIZ		CARTRIDGE		DISCHARGE PLENUM
	INLET PLENUM	2" & 4" FLAT	INTEGRAL	1 & 2 ROW STEAM AND 1 - 4 ROW WATER	MEDIUM	CLG. 10 ROW	PLENUM FAN		CLG. OR HTG.		BAG		
	ESI FAN	CARTRIDGE	EXTERNAL		SMALL	4 ROW	ESI FAN						
	MIXBOX WITH 4" FILTER	BAG	RIGHT ANGLE			SFA COIL MFA COIL F & BP	FAN ARRAY						
MIXING BOX	MIXBOX WITH 2" FILTER												
	MIXBOX WITH ANG FILTER												



Fans

Fan types available with the Daikin Skyline air handling units are housed double width, double inlet (DWDI) forward curved and airfoil fans, plenum fans, inline fans, twin fans and fan array. Forward curved fans generally provide the lowest first cost option and are used for lower static pressure applications.

DWDI Housed Fans

Daikin housed forward curved fans will typically operate up to 6.0" of static pressure. Airfoil fans have a higher first cost, but are more efficient, quieter and can handle higher static pressures. Daikin housed airfoil fans will operate up to 9.0" of static pressure.

Plenum Fans

Plenum fans (Figure 5) save space by eliminating turns in ductwork. They also provide a high degree of flexibility when locating the outlet ductwork. Plenum fans are also very good for blow-through applications as they generate a uniform outlet velocity profile. Both belt drive and direct drive plenum fans are available.

Direct drive plenum fans offer easier maintenance as they do not have fan bearings, sheaves, or belts.

Dual Fans

Direct drive plenum fans come with the optional dual arrangement. The multi-fan sets will provide more even air flow and redundancy if one fan should need servicing.

For redundancy, the rule of thumb is that one fan will provide approximately 65% of the total CFM provided by both fans if the remaining fan is not sped up. If more redundancy is required, then a VFD and larger motor can be used to speed up the single fan to achieve more airflow. The selection software will calculate the redundancy. If a manual calculation is required to calculate the maximum available airflow from the single fan, manually plot the single fan performance onto the dual fan curve as in Figure 6. Extend the single fan rpm line to intersect with the system static pressure line. This balance point shows the performance of a single fan when one fails.

Figure 5: Plenum Fan



If a VFD is used, the fan can be sped up to the limit of the HP of the motor to get more airflow. To increase redundancy, a larger motor can be selected. Remember that over sized fan motors may be less efficient. This typically occurs below 50- 60% design bhp. If you over size the motor to increase redundancy, as the motor BHP drops farther away from the actual HP, the motor will run less and less efficiently. So, if the application is meant for dual fans, it may be best to simply use the best selection for efficiency and utilize what redundancy comes with this selection. This will ensure the customer will have the most efficient operating setup while having the insurance of good redundancy.

The width of the fans will determine which cabinets will allow certain fans. Table 1 will help by showing what minimum cabinet width and unit size you will need for specific fan diameter selections.

An optional motor removal gantry system is available for the Dual Plenum Fan and Fan Array options. The gantry option provides easier serviceability of motors if access is not available on both sides of the fan section.

Table 1: Dual Fan Width Requirements

Direct-Drive Plenum Fan Size	Minimum Width (in.)	Minimum Standard Unit Size
11	64	010
12	64	010
15	68	014*
16	72	014*
18	80	017
20	88	030*
22	92	030*
24	100	035*
27	108	040
30	116	040
33	124	065
36	136	065

* Not on 4" widths

Figure 6: Dual Fan Redundancy – 65% If One Fan Fails

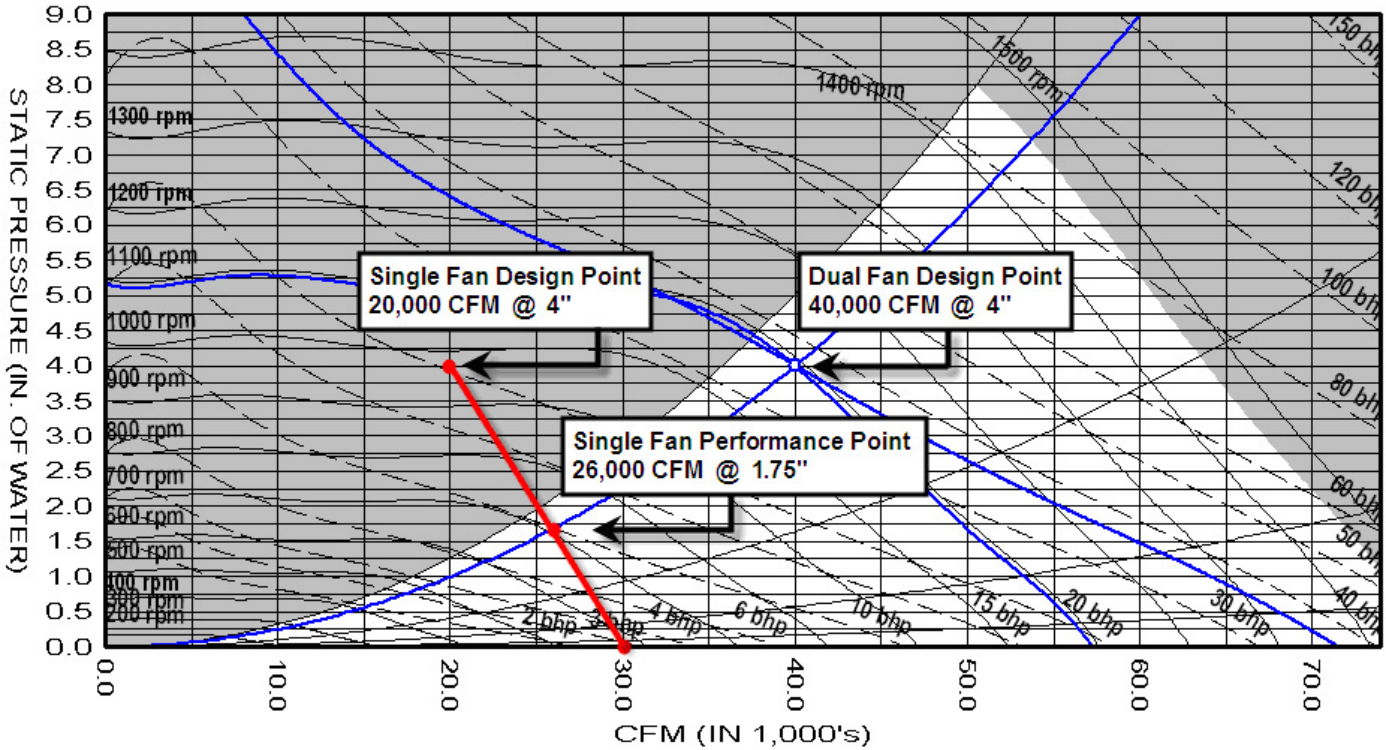

Fan Array

The fan array section will decrease the fan section length by using multiple smaller direct-drive fans. With the stacked array, the fans will also provide a more even airflow pattern throughout the unit and will allow the fans to be placed closer to the coil. Multiple fans also provide redundancy, allowing the system to deliver full airflow and static pressure if a fan or motor is lost. All fans in the fan array are direct-drive and offer more efficient performance with no belt losses and no required shaft bearing maintenance.

The DDPL fan array section has fan diameters from 12–33 inches, with arrangements of up to 24 fans. Daikin offers three motor control options to meet the highest level of redundancy. The array can be selected with a single VFD, a VFD per row or a VFD per fan. Each fan will come with an individual motor starter and backdraft prevention allowing complete isolation of any fan.

The ECM fan array section has a brushless, permanent magnet motor(s) for maximum efficiency. The inverter is integral to the motor. Each fan will come with an individual motor starter and optional backdraft prevention allowing complete isolation of any fan.

Figure 7: Nine-Fan Option



Figure 8: ECM Fan Option



Coils

The Daikin Skyline outdoor air handler offers broad application flexibility in coil sections and coils. Coils can be arranged in draw-through or blow-through configurations. Heating only, cooling only, or cooling and heating sections are available. All coils are installed with space between each coil to allow access for cleaning and mounting of controls.

Cooling coil sections, and cooling and heating coil sections, are available in seven different section lengths to accommodate every application requirement. Drain pans extend the full length of the section. Removable access panels or doors may be provided in the deeper sections that will not interfere with piping connections extending through the unit side panels or piping vestibules.

All cooling coils are mounted over a double sloped drain pan. The cooling coil rests on coil supports located over the drain pan. The drain pan extends beyond the leaving side of the coil to help recover condensate. The primary drain pan also extends under the coil headers and return bends to help remove condensate from the unit. A full thickness of insulation is always provided between the drain pan and the bottom outer panel. The drain pan is sloped in two planes to promote proper condensate removal.

Coil connections are grommet sealed inside and outside to ensure low cabinet leakage, and the connections always extend through the unit cabinetry, allowing for the easy connection of valves and piping (Figure 9). All valves and piping can be enclosed within a piping vestibule that is available in varying depths to meet piping requirements. Water coil vents and drains are located outside the cabinetry.

Coils are available in a range of face area sizes, including small, medium, large staggered. Generally, small face area coils are used for heating applications with bypass and medium and large face area coils are used for cooling applications with bypass.

With Daikin being a major manufacturer of heat transfer coils, the coil options are virtually unlimited. The Daikin contractor coil line has several coil types, ranging from hot and cold water, refrigerant and steam. Standard Daikin coils are AHRI certified. In addition to a broad range of circuitings, fin spacing and row depths, coils can be constructed of different material types for fins, tubes, connections, and casings. This provides the ability to specify a coil to meet the application requirements.

For more information on Daikin coils, consult the following catalogs:

- Cooling**—water/refrigerant.....Catalog 411
- Heating**—water/booster..... Catalog 412
- Steam**—standard/distributing..... Catalog 413

Figure 9: Coil Connections, Vents, Drains, and Drain Pan Connection, Extend Through Unit Cabinetry



Filters

The Daikin Skyline outdoor air handler is designed to house flat, angular, bag, or cartridge filters. These media types range in efficiencies up to 95% and MERV 15. (See page 18 for a description of the MERV Rating.) In addition to offering a full range of efficiencies, the filter media can be provided with an optional antimicrobial treatment. Antimicrobial treatments are highly recommended for a complete filtration system.

An optional filter pressure gauge may be ordered with each filter section to help promote regular servicing and prevent clogging.

Both bag and cartridge filters have a pre-filter and can be either side load or front load. An access door is provided on either side or both sides of the unit to access the filter section. Filters can be positioned any place in the unit, and as many filter sections as required can be used. Many health and food industries require stringent filtration. Often, a filter section must be the last component in the air stream.

Figure 10: Filter Particle Size Chart (in microns)

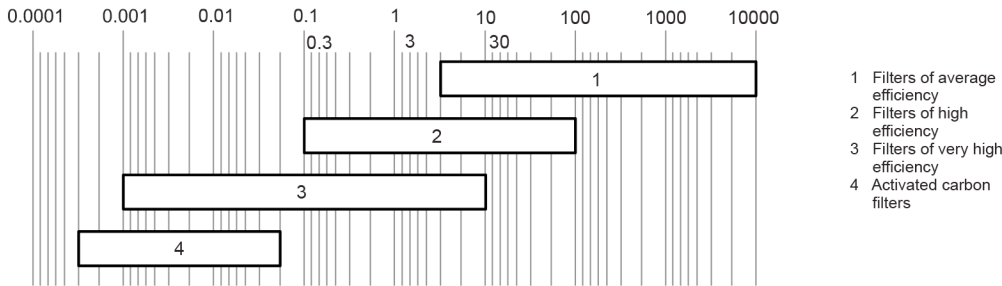
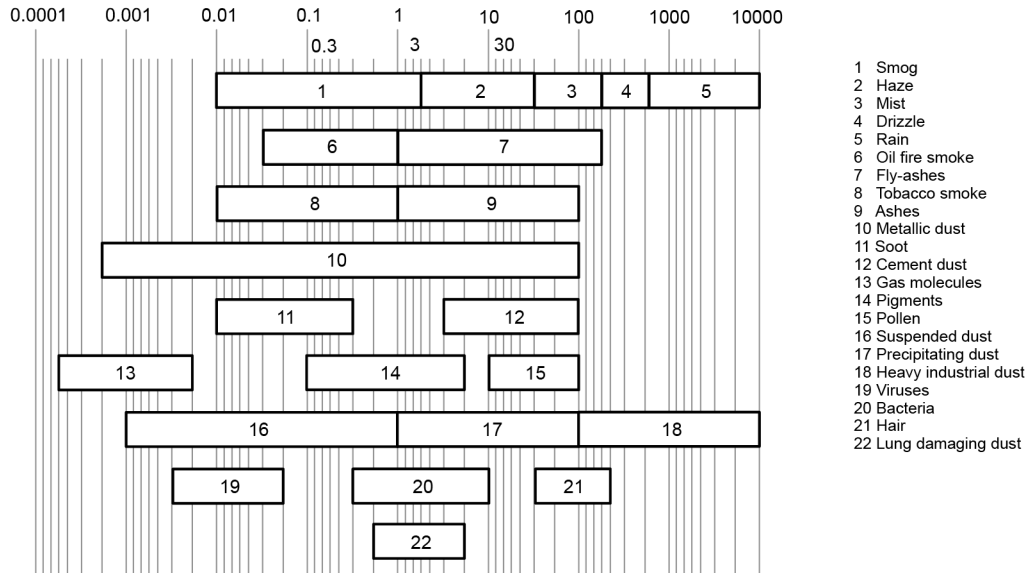

Figure 11: Pollutant Particle Size Chart (in microns)



What is the MERV Rating?

Minimum Efficiency Reporting Value (MERV)—ASHRAE Standard 52.2-1999 entitled “Method of Testing General Ventilation Air-Cleaning Devices for Removal by Particle Size” provides a methodology for determining filter efficiency at removing various sizes of particles (see Figure 10 and Figure 11) as the filters become loaded. There are three ranges of particle sizes that define the MERV value:

Range 1—0.3 to 1.0 .m particle size.

Range 2—1.0 to 3.0 .m particle size.

Range 3—3.0 to 10.0 .m particle size.

The Table 2 shows a comparison of the MERV rating to the average arrestance percentage by the older ASHRAE Standard 52.1 method:

Table 2: MERV Rating vs. AHSRAE Standard 52.1

Standard 52.2 (MERV)	Approximate Standard 52.1		Particle Size Range
	Dust Spot Efficiency	Arrestance	
15	>95%	N/A	1
14	90 to 95%	>98%	1
11	60 to 65%	>95%	2
8	30 to 35%	>90%	3
6	<20%	85 to 90%	3

Standard Filter Types Available:

- MERV 8 – 2" or 4" depth. Pleated filter with two layers of added polypropylene laminate to increase efficiency.
- MERV 13 – 2" or 4" depth without 1" track.
- MERV 14, 13, and 11 – 4" depth, 1" track requirement. Mini pleated filters with metal cell sides and headers that provide superior moisture resistance.
- MERV 14, 13, and 11 – 12" depth, 1" track requirement. Steel interlocked header and cell sides hold the corrugated aluminum separated pleats allowing optimum airflow. Rated UL Class 1.
- MERV 14, 13, and 11 – 12" depth, 1" track requirement. Mini pleats held in a V-bank configuration providing greater airflow capacity and longer service.
- MERV 15, 14 and 12 – 36", 30" and 22" depths, 1" track requirement. Extended surface pockets made from high-loft, layered synthetic media. Rated UL Class 1 MERV 8 efficiency filters also available in 19", 15" and 12" depths.
- HEPA (MERV 17)
 - 99.99% – 0.3 mm (HEPA)
 - 99.999% – 0.3 mm (ULPA)
 - 99.99995% – 0.1 to 0.2 mm (ULPA)

Gas Heat

Freezing coils on rooftop air handlers is always a possibility. Gas heat can be an economical way to provide heat and eliminate the possibility of freezing coils. The gas heat option is available with capacities up to 4.8 million BTU/hr and turndowns up to 40:1.

The gas heat section will be equipped with all the necessary controls and safeties. Only an analog signal (0-10Vdc) is required for control of the furnace.

Single Furnaces

Daikin gas heaters are available for small morning warm up applications (single stage) with as little as 80 Mbtu/hr. Single furnaces can also be used for 100% outdoor requirements with models available with turndowns as high as 10:1.

Dual Furnaces

Where even higher turndowns are required, many selections will be available with dual furnaces with turndowns as high as 20:1. This is done by putting a high turndown option on one furnace and staging the other furnace.

Rack configurations

Rack configurations are used for large heating capacities and will involve up to 5 furnaces being stacked. This will allow for high turndown operation (up to 40:1).

Figure 12: Rack Configurations



Access

Access sections can be selected to meet specific application criteria. They can be placed anywhere in a unit in a variety of depths and are available in depths of 16", 24", 30", 36", 42", 48", and 54". Typically, access sections are used for field-installed components, air monitoring devices, or to provide ample space between components.

Mixing Boxes and Economizers

When outside and return air mixing is required, either a mixing box or an economizer section can be selected. Either component will regulate the amount of outside and return air supplied to the conditioned space. The mixing box or economizer can make use of free cooling by opening outside air dampers when the ambient air will help to condition the supply air stream. Additionally, dampers may be individually sized to provide better mixing.

Both the mixing box and economizer are provided with a Daikin UltraSeal low leak damper. This damper has one of the lowest leakage rates in the industry, maximizing energy efficiency. At 4.0" static pressure and a face velocity of 1100 fpm through the dampers, the leakage rate is less than 0.2% (it is common to specify leakage rates at higher static pressures, but dampers should not exceed 2" of static pressure). The parallel airfoil blades are hollow core and fully gasketed. Continuous vinyl seals are provided between the damper blades. Stainless steel end seals and linkage built into high strength ABS plastic endcaps provide smooth, quiet operation. Mixing boxes or economizers used on Daikin Skyline outdoor air handlers can include optional factory-installed rain hoods.

Face and Bypass Dampers

Face and bypass dampers can be provided to modulate temperature by bypassing air around the coil. The opposed blades meter varying air volumes through the coil and bypass to attain the final air temperature demanded. Daikin Skyline air handlers offer only low leak dampers in their face and bypass sections.

Three styles of face and bypass sections are available.

- Internal bypass is available for use with medium face area coils (Figure 13).
- External bypass and external right angle are used when larger face area coils are required. The damper blades are fabricated of continuous galvanized steel with the damper rods rotating in nylon bushings. Damper shaft extensions are supplied to facilitate damper motor location.
- Integral face and bypass. air handlers are pre-engineered to provide an accurate, reliable method of preheating and tempering air in standard or make-up air applications. Integral face and bypass coils maintain constant steam pressure or tube velocities through the coil to help prevent freeze-ups, while varying airflow through the coil using bypass dampers. The amount of air bypassed or heated is determined by a preset leaving air temperature. It can vary from the bypass dampers being fully closed (all air passes through the coil) for maximum heat output, to the bypass dampers being fully open (no air passes through the coil) for minimum heat output. The air is then mixed at the discharge of the coil to achieve the desired leaving air temperature. Air pressure drop is maintained constant regardless of the position of the dampers.

Figure 13: Internal Face and Bypass Dampers



Blenders/Air Mixers

Stratification can occur from the mixing box when airflow from two different temperature air streams do not mix completely. This incomplete mixing can continue through the air handler and subject an unprotected coil (no glycol) to freezing temperatures, damaging the coil. With the increased minimum outdoor air requirements as identified by ASHRAE Standard 62, the likelihood for air stratification increases. An air handler must be able to handle the required amount of outdoor air, regardless of temperature, without risking damage to the coil.

Blenders/air mixers help to provide protection for coils against freeze-up due to stratification. They add additional turbulence to the passing air streams, boosting the air velocity for improved mixing. Proper distance is provided immediately downstream to give the air streams enough time to fully mix before reaching the next air handler component. Because blenders/air mixers are static devices, they require no maintenance. Different blender/air mixer lengths can be selected to satisfy either the acoustic, space, pressure drop, or initial cost requirements. The Daikin SelectTools software can help select the appropriate blender/air mixer for the application.

Figure 14: Blender

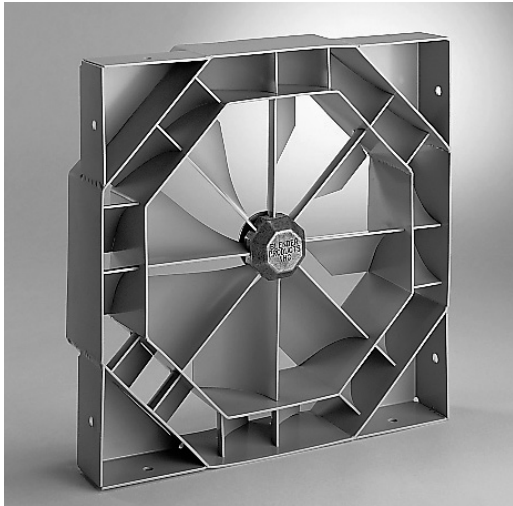

Attenuators

Building occupants have become increasingly conscious of the quality of their environments, and low sound levels are a key criteria. Studies have confirmed improved productivity when workers are performing in sound-controlled environments. Consequently, building owners, engineers, and architects are designing their projects with stringent sound criteria to maximize this economic benefit.

Daikin Skyline outdoor air handlers are designed to provide quiet sound levels. Factory-installed attenuators are available for the discharge or return sections of the air handling unit to meet the most stringent sound attenuation requirements. Different attenuator lengths can be selected to satisfy either the acoustic, space, pressure drop, or initial cost requirements. Quality construction and an aerodynamic design give reliable performance, low pressure drop and low initial cost. The Daikin SelectTools Software can help choose the correct attenuator for your application.

Figure 15: Attenuator Section



Selecting flexible Skyline outdoor air handlers depends on many different criteria. The Quick Select tables on [page 23](#) and [page 24](#) provide a rough determination of air handler needs. To simplify this process, Daikin designed an innovative computerized selection program—Daikin SelectTools software. It allows the user to develop an air handler from the ground up and obtain all of the detail required for proper design and specification. The user can design a unit in a matter of minutes.

The program is completely integrated. All input data is carried through the selection process and considered as calculations are made. Because the program is integrated, the opportunity for errors is reduced. The software guides the user through the selection process. On-line editing helps select only viable options. The program is provided so that even the less experienced user can select air handlers accurately.

Designing an efficient air handler system depends on accurate system design and proper equipment selection. Factors that affect unit selection include applicable codes, ventilation requirements, heating and cooling space loads, acceptable temperature differentials, and thermal media and installation limitations. Unit selection can be broken down into four steps: unit type and size, coils, accessories, and fan and motor requirements.

Generally, the unit is selected based on the air volume required and the desired face velocity through the cooling coil. For cooling coils, 400 to 525 feet per minute is considered the optimum face velocity range for dehumidification and the prevention of any moisture carryover. The Daikin SelectTools software recommends the unit size based on air flow and face velocity requirements. Once the unit size is determined, select the coils and all accessory components. Once all components and coils are selected (identifying the total internal component pressure drop), select the fan.

Energy Recovery

Maintaining acceptable indoor air quality is generally accomplished by introducing ventilation from outdoors. The air must be conditioned to match the indoor space requirements. Heat wheels are available as factory-installed options for Skyline air handlers. These energy recovery components can

recover 50% or more of the energy normally exhausted from a building. These devices capture heat from exhaust air as it passes through the air handler and transfer it to the supply air stream, reducing the cost of heating or cooling the outside air. Energy recovery components do this by transferring energy from a warm air stream to a colder air stream—heating cold outside air during the winter and cooling hot air during the summer.

The heat recovery wheel rotates at low speeds, capturing and transferring both sensible (heat) energy and latent (moisture) energy. The ability to transfer both sensible and latent energy gives the heat wheel several advantages. First, the required capacity of ventilation equipment is significantly reduced. Additionally, the heat wheel works at lower temperatures without frosting. The supply air from the heat wheel is not near saturation, and moisture in the ductwork is not an issue.

Further, no condensate pan or drain is required. Finally, heat wheels provide humidification so that the humidifier can be downsized. They also help to keep humidity in spaces where humidification is not applied, providing greater comfort to these zones. Heat wheels are configured on the inlets and outlets with splice collars to match the adjacent sections.

Selecting Coils

The Skyline air handler provides the ability to select from multiple face area coils per unit size. Once the coil size is selected, the row and fin requirements can be determined based on performance criteria. Daikin offers an extensive line of coil types and circuitings. This wide variety of circuiting, row, and fin spacing, in addition to different material types, can provide a coil selection that handles the load required.

Heating, cooling, and combination cooling and reheat sections are available. Coil sections come in many different depths to accommodate multiple rows of coils, and to provide access on the leaving air side or between coils for cleaning and inspection of the drain pan. Access in the coil section can be minimized or maximized depending on the space available and job needs. Coil sections can be placed as needed in the unit, and as many sections as required for conditioning of air can be provided.

Selecting Accessories

A complete selection of component and section types in a variety of unit arrangements and configurations is available for air mixing, filtration, and temperature control to meet specific application requirements. The outside and/or return air can be brought into the unit through a plenum, mixing box, or economizer. For mixing of the two air streams, dampers are required to modulate and direct outside and return air, which is accomplished using a mixing box or economizer. Both section types use the Daikin patented UltraSeal low leak dampers. Blenders/air mixers also are available to provide proper mixing of two air streams, to prevent stratification and to help avoid damage to equipment due to freezing temperatures.

To promote good air filtration, many different filter media types and arrangements are offered. Filters can be provided in angular or flat filter racks, a variety of media efficiencies, and with or without a prefilter. The filter section can be located anywhere in the unit to filter air as it enters the unit, or in a final filter arrangement before it leaves the unit. Bag or cartridge filters can be either front or side loading.

Also available are many different size access sections for field-installed components or to provide access between components. Other options include diffusers, plenums, face and bypass dampers, sound attenuators, and blenders/air mixers. Standard access doors open outward for maximum accessibility to internal components.

Selecting Fans

WARNING

SMOKE CONTROL AND MANAGEMENT SYSTEMS

Improper smoke or fume air handling can result in severe personal injury or death. A registered professional engineer must design and approve the air conditioner and air handler application to make sure smoke and fume control meet local fire codes and NFPA requirements for the specific building application.

Fan selection requires an accurate calculation of the resistance to the airflow through the entire system. This total resistance consists of the sum of two parts—the external and internal static pressure. The external static pressure is the static pressure found in the distribution system, external to the air handler. The internal unit resistance is the sum of the resistance of the coils and various other unit components and accessories. Component pressure drops are listed for specific air flows in this catalog.

Use the Daikin SelectTools software to determine internal component pressure drops of the system. Once the total static pressure is known, the software identifies the fans available to properly handle the air flow and static pressure for the system. The software generates a full fan curve based on the fan selection and point of operation.

Table 3: Quick Select Table, Sizes 003 to 021

Description	Unit size								
	003	004	006	008	010	012	014	017	021
Airflow range, CFM	900–2500	1200–3100	1700–4600	2200–6000	2900–7700	3600–9700	4200–11200	5000–13500	6000–16000
CFM @ 500 ft/min through large face area coil	1550	1950	2850	3750	4800	6050	7000	8400	10050
Height × width (in.)	34 × 38	38 × 40	38 × 52	40 × 58	44 × 64	50 × 66	50 × 74	52 × 80	58 × 82
Cooling coil face area, sq. ft.									
Extended/staggered large	3.9	4.8	6.6	8.5	10.7	13.5	15.4	18.3	21.9
Large	3.1	3.9	5.7	7.5	9.6	12.1	14.0	16.8	20.1
Extended/staggered medium	2.6	3.4	4.7	6.4	8.3	9.8	11.2	13.7	17.2
Medium	2.1	2.8	4.1	5.6	7.4	8.8	10.2	12.6	15.8
Small	NA	2.3	3.3	4.7	6.4	7.7	8.9	11.2	14.4
Fan section—depth (in.)									
Largest housed fan and motor avail. w/ top hor. dischg.	32	32	36	40	40	46	46	50	52
Largest inline fan and motor available	N/A	N/A	N/A	N/A	N/A	44	44	48	54
Largest belt drive plenum fan and motor available	N/A	N/A	32	32	34	40	40	44	48
Largest direct drive plenum fan and motor available	N/A	36	36	42	46	50	50	58	60
Largest dual direct drive plenum fan and motor available	N/A	36	36	42	46	50	50	58	60
Largest ECM fan available	N/A	30	30	30	30	30	30	30	30
Mixing box—depth (in.)									
Mixing box only	20	20	20	20	22	24	24	26	30
Economizer—depth (in.)									
	66	66	70	66	74	72	77	80	84
Blender—depth (in.)									
Largest Kees	18	20	24	26	28	34	36	38	42
Largest Blender Products IV	18	22	26	30	34	38	40	46	48
Side load filter sections—depth (in.)									
Flat 2" and 4"	12	12	12	12	12	12	12	12	12
2" angular	32	32	32	32	32	32	32	30	30
Cartridge (12" deep w/ 2" pre-filter)	22	22	22	22	22	22	22	22	22
Bag (36" w/ 2" pre-filter)	42	42	42	42	42	42	42	42	42
Front load filter sections—depth (in.)									
Cartridge (12" deep w/ 2" pre-filter)	16	16	16	16	16	16	16	16	16
Bag (36" w/ 2" pre-filter)	40	40	40	40	40	40	40	40	40
Face and bypass—depth (in.)									
Internal	12	12	12	12	12	12	12	12	12
External	18	18	18	20	22	24	24	26	30
Coil sections—depth (in.)									
Heating only (2-row water)	12	12	12	12	12	12	12	12	16
Cooling only (4-row water)	24	24	24	24	24	24	24	24	24
Cooling only (6-row water)	24	24	24	24	24	24	24	24	24
Cooling & reheat (12-row cooling & 1-row heating)	36	36	36	36	36	36	36	36	36
Access sections—depth (in.)									
16" deep	16	16	16	16	16	16	16	16	16
24" deep	24	24	24	24	24	24	24	24	24
30" deep	30	30	30	30	30	30	30	30	30
36" deep	36	36	36	36	36	36	36	36	36
42" deep	42	42	42	42	42	42	42	42	42
48" deep	48	48	48	48	48	48	48	48	48
54" deep	54	54	54	54	54	54	54	54	54
Diffuse—depth (in.)									
With housed fan	10	10	10	12	12	16	16	16	16
With inline fan	N/A	N/A	N/A	N/A	N/A	18	18	18	22
Attenuator—depth (in.)									
Short	40	40	40	40	40	40	40	40	40
Medium	52	52	52	52	52	52	52	52	52
Long	64	64	64	64	64	64	64	64	64
Supply or return plenum—depth (in.)									
Top, bottom or end opening	14	16	16	18	20	22	22	24	28

Notes: Values based on typical industry sizes. Skyline air handler units are available in 2-inch increments of height and width to fit exact space requirements. Height dimension includes 6" curb-ready base. Only horizontal units are available. Upblast and downblast poises not available for either housed fans or twin fans.

Table 4: Quick Select Table, Sizes 025 to 090

Description	Unit size								
	025	030	035	045	055	065	080	085	090
Airflow range, CFM	7300–19400	8500–22500	10000–26500	9600–25500	11400–30200	20000–54000	21500–57500	23100–61600	24600–65600
CFM @ 500 ft/min through large face area coil	12150	14150	16700	21300	25200	33300	35900	38450	41000
Height × width (in.)	66 × 86	66 × 98	72 × 102	84 × 106	96 × 106	92 × 136	98 × 136	104 × 136	110 × 136
Cooling coil face area, sq. ft.									
Extended/staggered large	27.4	31.9	37.1	50.4	N/A	76.9	82.0	87.1	92.2
Large	24.3	28.3	33.4	42.6	50.4	66.6	71.8	76.9	82.0
Extended/staggered medium	21.3	24.8	29.7	34.9	46.5	61.5	61.5	66.6	71.8
Medium	18.2	21.2	24.1	31.0	38.8	51.2	51.2	56.4	61.5
Small	16.7	19.5	22.3	27.1	34.9	46.1	46.1	51.2	56.4
Fan section—depth (in.)									
Largest housed fan and motor avail. w/ top hor. dischrg.	58	58	58	58	60	92	92	92	92
Largest inline fan and motor available	64	64	70	82	82	96	96	96	96
Largest belt drive plenum fan and motor available	50	54	54	52	60	68	68	68	68
Largest direct drive plenum fan and motor available	66	66	66	74	78	78	78	78	78
Largest dual direct drive plenum fan and motor available	66	66	66	74	78	78	78	78	78
Largest twin fan and motor available	66	74	82	78	78	N/A	N/A	N/A	N/A
Largest ECM fan available	N/A	30	30	30	30	30	30	30	30
Mixing box—depth (in.)									
Mixing box only	32	32	36	42	48	46	50	54	56
Mixing box with flat filter	—	—	—	—	—	50	54	58	60
Mixing box with angular filter	—	—	—	—	—	68	72	76	78
Economizer—depth (in.)									
	84	86	100	88	112	92	100	108	112
Blender—depth (in.)									
Largest Kees	46	48	58	64	68	76	80	84	84
Largest Blender Products IV	52	60	64	70	70	88	88	92	92
Side load filter sections—depth (in.)									
Flat 2" and 4"	12	12	12	12	12	12	12	12	12
2" angular	32	32	32	32	32	32	32	32	32
Cartridge (12" deep w/ 2" pre-filter)	22	22	22	22	22	22	22	22	22
Bag (36" w/ 2" pre-filter)	42	42	42	44	44	42	42	42	42
Front load filter sections—depth (in.)									
Cartridge (12" deep w/ 2" pre-filter)	16	16	16	20	20	16	16	16	16
Bag (36" w/ 2" pre-filter)	40	40	40	44	44	40	40	40	40
Face and bypass—depth (in.)									
Internal	12	12	12	12	12	12	12	12	12
External	32	32	34	44	50	50	54	56	58
Coil sections—depth (in.)									
Heating only (2-row water)	12	12	12	16	16	12	12	12	12
Cooling only (4-row water)	36	36	36	48	48	18	18	18	18
Cooling only (6-row water)	42	42	42	48	48	24	24	24	24
Cooling & reheat (12-row cooling & 1-row heating)	42	42	42	42	42	36	36	36	36
Access sections—depth (in.)									
16" deep	16	16	16	16	16	16	16	16	16
24" deep	24	24	24	24	24	24	24	24	24
30" deep	30	30	30	30	30	30	30	30	30
36" deep	36	36	36	36	36	36	36	36	36
42" deep	42	42	42	42	42	42	42	42	42
48" deep	48	48	48	48	48	48	48	48	48
54" deep	54	54	54	54	54	54	54	54	54
Diffuse—depth (in.)									
With housed fan	24	24	24	30	30	30	30	30	30
With inline fan	26	26	28	30	32	38	38	38	38
Attenuator—depth (in.)									
Short	40	40	40	40	40	40	40	40	40
Medium	52	52	52	52	52	52	52	52	52
Long	64	64	64	64	64	64	64	64	64
Supply or return plenum—depth (in.)									
Top, bottom or end opening	30	30	32	36	40	42	48	52	54

Notes: Values based on typical industry sizes. Skyline air handler units are available in 2-inch increments of height and width to fit exact space requirements. Height dimension includes 6" curb-ready base. Only horizontal units are available. Upblast and downblast poises not available for either housed fans or twin fans.

Installation Flexibility

Daikin central station Skyline air handlers feature sectionalized design and can ship fully assembled or in sections as required by the job site condition to provide maximum installation flexibility. Multiple fan, coil, filter, mixing box, face and bypass, and access components allow the design flexibility of built-up systems with the cost advantage of factory fabricated units.

Unit Location

The structural engineer should be involved to verify that the roof has adequate strength and ability to minimize deflection. Exercise extreme caution when using a wooden roof structure. Locate units away from building flue stacks or exhaust ventilators to prevent possible entry of contaminated air through the outside air intake. Allow sufficient space around the unit for service clearance.

Locating the unit away from occupied spaces and over utility areas, corridors, and auxiliary spaces helps reduce the transmission of sound and vibration to occupied spaces. A concrete deck or pad is recommended when the unit is located over an occupied space where good acoustics are essential.

Curb Installation

The roof curb is field assembled and must be installed level (within 1/16 in. per foot, side to side). In applications involving pitched roofs, the contractor must construct a sub-base. Gaskets are furnished and must be installed between the unit and curb. For proper installation, follow NRCA guidelines. In applications requiring post and rail installation, an I-beam securely mounted on multiple posts should support the unit on each side.

Applications in geographic areas that are subjected to seismic or hurricane conditions must meet code requirements for fastening the unit to the curb and the curb to the building structure.

Ductwork

A well-designed duct layout minimizes system resistance and sound generation. Duct connections to and from units should allow straight, smooth airflow. Avoid any abrupt change in duct size. Also avoid sharp turns in the fan discharge, particularly turns opposed to wheel rotation. If sharp bends are necessary, use turning vanes. See Figure 16 for good fan outlet practices.

Figure 16: Discharge Duct Layout

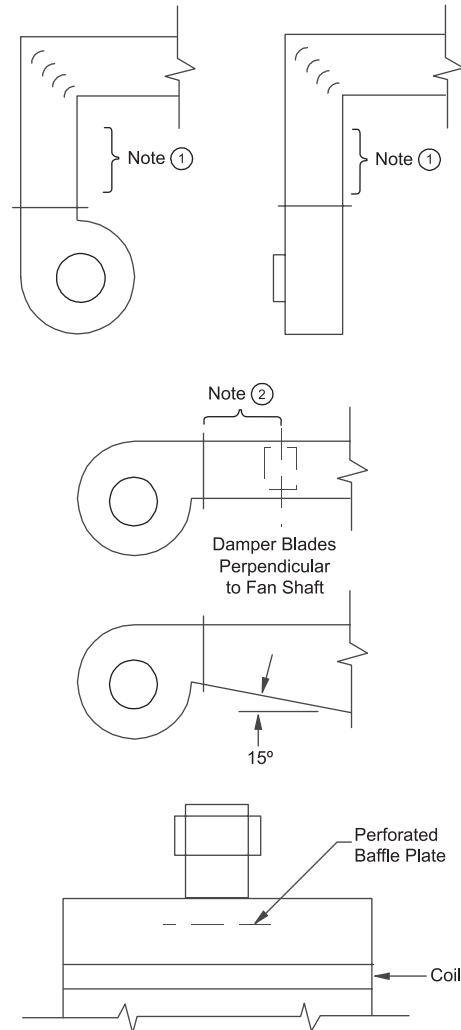

NOTE: Elbows should not be closer than 1 1/2 to 2 1/2 times the largest dimension of fan discharge opening. Place dampers at least 3 fan diameters downstream of the fan discharge.

Figures reprinted with permission from the 1979 ASHRAE Guide and Data Book (Equipment).

Piping and Drain Pan Traps

Design and install piping in accordance with accepted industry standards. Do not apply undue stress at the connection to coil headers. Support pipe work independently of the coils with adequate piping flexibility for thermal expansion. Run drain lines and traps full size from the drain pan connection. Drain pans must have traps to allow the condensate from the coils to drain freely. On a draw-through unit, the trap depth and the distance between the trap outlet and drain pan outlet should be twice the negative static pressure under normal unit operation. See Figure 17.

Figure 17: Drain Pan Traps

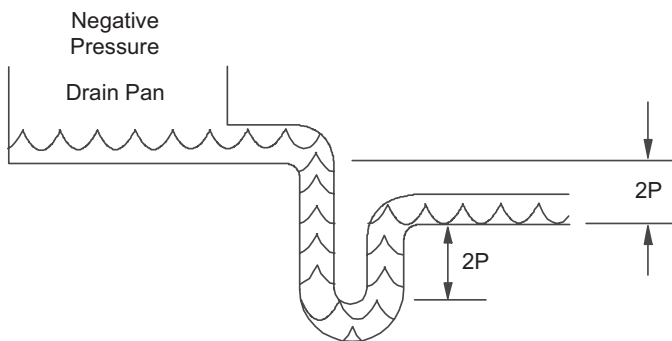

Coil Freeze Protection

When applying the Skyline outdoor air handler in geographic areas that experience subfreezing conditions, provide coil freeze protection measures. Subfreezing temperatures can adversely affect water and steam coils during controlled or uncontrolled unit shutdowns and even during unit operation. Some temperature stratification will occur, particularly at low ambient temperatures. When required, static air mixers/blenders are available that can significantly improve mixing and reduce stratification. This can result in improved protection against freeze-up.

Glycol is strongly recommended as a positive means of freeze protection for water coils. No control sequence can prevent coil freezing in the event of a power failure or equipment malfunction. During those periods, glycol is the only positive means of freeze protection. When selecting water coils, specify glycol to account for performance differences.

Vibration Isolation

To help keep noise and vibration compatible with the intended use of the conditioned air space, apply good acoustical and vibration engineering practices during the early stages of design.

Since most applications require vibration isolation, the Skyline outdoor air handler is available with factory-installed internal isolation. Internally isolated units feature spring or rubber in shear isolators sized specifically for each fan wheel and unit size.

Sound

The unit inlet, outlet, and radiated sound levels for each octave band are calculated by the Daikin SelectTools software, based on your specific application. Sound performance data is derived from testing performed in accordance with AMCA Standard 300. The effects of various components, casework, and unit configurations are taken into account.

Filters

Routinely replace filters to minimize filter loading. As filters get dirty, the filter pressure drop increases, causing a decrease in airflow. Depending on fan type, this airflow change can be significant. The effect of filter loading is the most critical when using 65% and 95% efficient filters.

When making a fan selection, in the system total static pressure, include a pressure drop component for filters since they get dirty. A value midway between clean and dirty filter ratings is recommended. If a minimum airflow is critical, base the selection of the fan rpm on the minimum airflow at the total static pressure associated with dirty filters. The motor horsepower then is determined by the selected rpm and the total static pressure assumed for dirty filters, which yields the largest brake horsepower. Following these recommendations should limit airflow fluctuation as the filters load.

Air Supply Systems and Fan Laws

An air supply system consists of an air handler cabinet, heat exchanger, filters, ductwork, grilles and registers used to distribute air throughout the building. The system is independent of the fan used to supply the system.

The resistance of the system, referred to as static pressure (SP), is dependent upon the quantity of air (cfm) that is moved through it. The air quantity is determined by the cooling, heating, and ventilating requirements.

For any system, the static pressure varies directly as the square of the air quantity. This relationship between cfm and SP establishes the system curve for that system and is expressed as follows:

$$\left(\frac{\text{cfm}_1}{\text{cfm}_2}\right)^2 = \frac{\text{SP}_1}{\text{SP}_2} \text{ or } \text{SP}_2 = \text{SP}_1 \left(\frac{\text{cfm}_2}{\text{cfm}_1}\right)^2$$

The system curve is unique for a particular system configuration. Any change to the system caused by dirty filters, damper changes, etc., results in a new system curve.

For fans operating at low pressures (less than 10" W.G.), the effects of air compression are negligible. Disregarding air compression allows fan operation in a fixed system to be expressed by simple relationships. These relationships are known as fan laws and can be used to calculate the effects of fan speed and air density changes on this system.

1. The flow rate varies directly with the change in fan speed:

$$\frac{\text{cfm}_1}{\text{cfm}_2} = \frac{\text{rpm}_1}{\text{rpm}_2} \text{ or } \text{cfm}_2 = \text{cfm}_1 \left(\frac{\text{rpm}_2}{\text{rpm}_1}\right)$$

A 10% increase in fan speed increases air quantity 10%.

2. The static pressure varies as the square of the change in fan speed:

$$\frac{\text{SP}_1}{\text{SP}_2} = \left(\frac{\text{rpm}_1}{\text{rpm}_2}\right)^2 \text{ or } \text{SP}_2 = \text{SP}_1 \left(\frac{\text{rpm}_2}{\text{rpm}_1}\right)^2$$

A 10% increase in fan speed increases static pressure 21%.

3. The fan brake horsepower varies as the cube of the change in fan speed:

$$\frac{\text{HP}_1}{\text{HP}_2} = \left(\frac{\text{rpm}_1}{\text{rpm}_2}\right)^3 \text{ or } \text{HP}_2 = \text{HP}_1 \left(\frac{\text{rpm}_2}{\text{rpm}_1}\right)^3$$

A 10% increase in fan speed increases horsepower 33%.

4. System static pressure and brake horsepower are directly proportional to the air density:

$$\text{SP}_2 = \text{SP}_1 \left(\frac{\text{density}_2}{\text{density}_1}\right) \left(\frac{\text{rpm}_2}{\text{rpm}_1}\right)^3$$

$$\text{HP}_2 = \text{HP}_1 \left(\frac{\text{density}_2}{\text{density}_1}\right) \left(\frac{\text{rpm}_2}{\text{rpm}_1}\right)^3$$

Consequently, the static pressure and brake horsepower decrease with an increase in air temperature or higher altitude, and increase with a decrease in air temperature or lower altitude.

To determine fan performance for temperatures and altitudes other than standard (70°F, 0 ft. altitude), the static pressure must be adjusted by the density ratio before the fan rpm and bhp requirements can be determined. Density ratios are expressed as temperature and altitude conversion factors in [Table 5](#).

Table 5: Temperature and Altitude Conversion Factors

Air temp. (°F)	Altitude (ft)								
	0	1000	2000	3000	4000	5000	6000	7000	8000
-20	1.20	1.16	1.12	1.08	1.04	1.00	0.97	0.93	0.89
0	1.15	1.10	1.08	1.02	0.99	0.95	0.92	0.88	0.85
20	1.11	1.06	1.02	0.98	0.95	0.92	0.88	0.85	0.82
40	1.06	1.02	0.98	0.94	0.91	0.88	0.84	0.81	0.78
60	1.02	0.98	0.94	0.91	0.88	0.85	0.81	0.79	0.76
70	1.00	0.96	0.93	0.89	0.86	0.83	0.80	0.77	0.74
80	0.98	0.94	0.91	0.88	0.84	0.81	0.78	0.75	0.72
100	0.94	0.91	0.88	0.84	0.81	0.78	0.75	0.72	0.70
120	0.92	0.88	0.85	0.81	0.78	0.76	0.72	0.70	0.67
140	0.89	0.85	0.82	0.79	0.76	0.73	0.70	0.68	0.65
160	0.85	0.82	0.79	0.76	0.74	0.70	0.68	0.65	0.63
200	0.80	0.77	0.75	0.72	0.69	0.67	0.64	0.62	0.60
250	0.75	0.72	0.69	0.67	0.65	0.62	0.60	0.58	0.56

Fan and Motor Heat

Motor and drive heat—The total energy input to any fan motor is consumed in two ways: by heat dissipated through the motor frame and by work output. The amount of heat dissipated by the motor is a function of its operating efficiency:

$$\text{Motor heat} = \text{input} \times (1 - \text{motor efficiency})$$

A small amount of the motor work output is dissipated by the drive mechanism, which also results in a heat gain. Belt drive losses are a function of belt tension and number of belts as well as power transmitted. Typical belt drive losses range from 2% to 6% of bhp.

Whether motor and drive heat gain become part of an air handling system cooling load depends on the motor location relative to the conditioned space. For air handlers with internal motors, the motor and drive are within the conditioned space. Therefore, the motor and drive add heat to the system. Subtract this heat from the cooling capacity and add it to the heating capacity of the unit.

Fan Heat Generation—All of the power input to a fan results in heat gain, which must be considered as a cooling load. The amount of heat generated is directly proportional to the fan bhp:

$$\text{Fan heat (Btuh)} = \text{bhp} \times 2545$$

Much of this heat generation occurs within the fan itself. Fans are not 100% efficient, and the energy losses that occur convert directly into heat. The work done by the fan on the airstream increases the temperature, pressure, and velocity of air. The heat of compression required to raise the airstream to this increased energy level is also a heat gain.

As the air travels throughout the building, its energy is deteriorated by friction, resulting in pressure drop. This is also heat gain, but it does not result in temperature rise because the air expands as the pressure is reduced. The expansion is a cooling process that offsets the heat generated by friction.

Typical fan and motor heat values are given in [Figure 18](#).

Figure 18: Fan and Motor Heat Gain

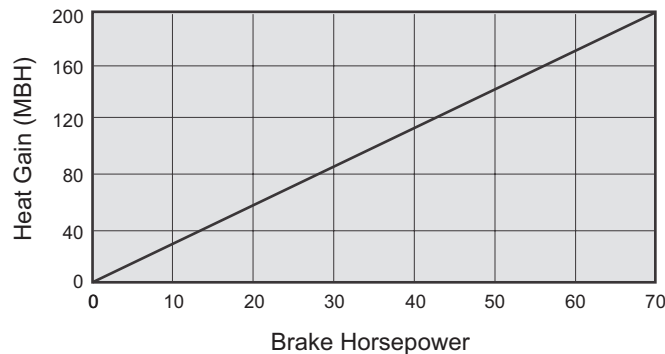

Variable Air Volume

Daikin variable air volume systems (VAV) employ the concept of varying the air quantity to a space at a constant temperature thereby balancing the heat gains or losses and maintaining the desired room temperature. This true variable volume system is commonly referred to as a “squeeze-off” or “pinch-off” system. Unlike a “bypass” or “dump” system, supply air is diverted from areas where it is not required to areas that need cooling and, at system part load conditions, reduces the total fan volume. This ability to reduce supply air quantities not only provides substantial fan energy savings at partial load conditions, but it also minimizes equipment sizing.

Variable volume systems offer the following advantages:

- Lowers system first cost by using system diversity to reduce equipment and duct sizes.
- Lowers operating costs by reducing fan energy demands, especially at part load conditions.
- Lowers first cost by reducing space requirements for duct trunks and mechanical equipment.
- Provides system flexibility to match changing occupancy demands.

Table 6: Component Pressure Drops (inches of water)

Unit Size	CFM	Dampers		F and BP face			F and BP by-pass			Plenum		Diffuser	Blender**			Attenuator		
		MXB	Econ.	Int. small	Int. med.	Large	Int. small	Int. med.	Large	Top/bot. inlet	Top/bot. outlet		One	Two	Three	3 ft	4 ft	5 ft
003	900	0.01	0.02	—	0.03	0.01	—	0.09	0.03	0.01	0.01	0.15	0.06	0.03	—	0.01	0.01	0.01
	1200	0.03	0.04	—	0.06	0.02	—	0.15	0.05	0.03	0.02	0.15	0.11	0.05	—	0.02	0.02	0.02
	1500	0.04	0.06	—	0.09	0.03	—	0.24	0.07	0.04	0.03	0.15	0.17	0.08	—	0.03	0.03	0.03
	1800	0.06	0.09	—	*	0.04	—	*	0.11	0.06	0.04	0.15	0.24	0.11	—	0.04	0.05	0.05
004	1200	0.02	0.03	0.05	0.03	0.01	0.05	0.14	0.04	0.01	0.01	0.15	0.04	0.05	—	0.01	0.01	0.01
	1600	0.04	0.06	0.09	0.06	0.02	0.08	0.24	0.06	0.03	0.02	0.15	0.07	0.08	—	0.02	0.02	0.02
	2000	0.06	0.09	*	0.09	0.03	*	0.38	0.10	0.04	0.02	0.15	0.11	0.13	—	0.03	0.04	0.04
	2400	0.09	0.13	*	0.13	0.05	*	0.54	0.14	0.06	0.03	0.15	0.16	0.18	—	0.05	0.05	0.06
006	1700	0.02	0.03	0.05	0.03	0.01	0.04	0.12	0.04	0.01	0.01	0.15	0.10	0.05	0.04	0.01	0.01	0.01
	2300	0.04	0.06	0.08	0.05	0.02	0.08	0.23	0.07	0.02	0.02	0.15	0.18	0.09	0.07	0.02	0.03	0.03
	2900	0.06	0.09	*	0.09	0.03	0.12	0.36	0.11	0.04	0.03	0.15	0.28	0.14	0.11	0.04	0.04	0.05
	3500	0.09	0.14	0.11	*	0.05	0.17	0.50	0.15	0.06	0.04	0.15	0.41	0.20	0.16	0.06	0.06	0.07
008	2200	0.03	0.04	0.04	0.02	0.01	0.06	0.16	0.04	0.01	0.01	0.15	0.07	0.05	0.03	0.01	0.01	0.02
	3000	0.05	0.07	0.07	0.04	0.01	0.10	0.30	0.08	0.03	0.01	0.15	0.14	0.09	0.06	0.02	0.03	0.03
	3800	0.08	0.12	*	0.06	0.02	0.15	0.48	0.12	0.04	0.02	0.15	0.22	0.15	0.10	0.03	0.04	0.05
	4600	0.12	0.17	*	0.09	0.03	0.22	0.70	0.18	0.06	0.03	0.15	0.32	0.22	0.14	0.05	0.06	0.08
010	2900	0.03	0.04	0.03	0.02	0.01	0.08	0.22	0.04	0.01	0.01	0.15	0.09	0.06	0.06	0.01	0.02	0.02
	3900	0.05	0.07	0.05	0.04	0.02	0.14	0.39	0.08	0.03	0.02	0.15	0.17	0.11	0.11	0.02	0.03	0.04
	4900	0.08	0.10	0.08	0.06	0.02	0.22	0.62	0.13	0.04	0.02	0.15	0.26	0.17	0.18	0.04	0.05	0.07
	5900	0.12	0.15	0.10	0.08	0.04	0.29	0.90	0.18	0.06	0.04	0.15	0.38	0.25	0.26	0.05	0.07	0.10
012	3600	0.03	0.04	0.03	0.02	0.01	0.08	0.11	0.04	0.02	0.01	0.15	0.05	0.06	0.06	0.02	0.02	0.02
	4800	0.06	0.07	0.06	0.03	0.01	0.14	0.20	0.07	0.03	0.02	0.15	0.10	0.11	0.11	0.03	0.03	0.04
	6000	0.09	0.11	0.09	0.05	0.02	0.21	0.31	0.11	0.04	0.02	0.15	0.15	0.17	0.16	0.05	0.06	0.06
	7200	0.13	0.16	0.11	0.08	0.03	0.28	0.45	0.16	0.06	0.03	0.15	0.22	0.25	0.24	0.08	0.08	0.09
014	4200	0.03	0.04	0.03	0.02	0.01	0.08	0.11	0.04	0.02	0.01	0.15	0.08	0.06	0.05	0.02	0.02	0.02
	5400	0.06	0.07	0.05	0.03	0.01	0.13	0.19	0.07	0.03	0.02	0.15	0.13	0.10	0.09	0.03	0.03	0.04
	6600	0.08	0.10	0.08	0.05	0.02	0.19	0.28	0.10	0.04	0.02	0.15	0.20	0.15	0.13	0.04	0.05	0.06
	8800	0.15	0.18	0.12	0.08	0.04	0.31	0.50	0.18	0.07	0.04	0.15	0.35	0.26	0.23	0.08	0.09	0.11
017	5000	0.03	0.04	0.02	0.02	0.01	0.09	0.14	0.02	0.02	0.01	0.15	0.07	0.06	0.05	0.02	0.02	0.02
	6700	0.06	0.07	0.04	0.03	0.01	0.17	0.25	0.04	0.03	0.02	0.15	0.12	0.11	0.09	0.03	0.03	0.04
	8400	0.09	0.11	0.07	0.05	0.02	0.26	0.39	0.06	0.05	0.02	0.15	0.19	0.17	0.14	0.04	0.05	0.06
	10100	0.13	0.15	0.10	0.08	0.03	0.38	0.56	0.08	0.07	0.03	0.15	0.27	0.25	0.20	0.06	0.08	0.10
021	6000	0.03	0.04	0.02	0.02	0.01	0.13	0.19	0.04	0.01	0.01	0.15	0.06	0.07	0.05	0.02	0.02	0.02
	8000	0.05	0.06	0.03	0.03	0.01	0.23	0.34	0.07	0.03	0.01	0.15	0.11	0.12	0.09	0.03	0.03	0.04
	10000	0.08	0.10	0.05	0.04	0.02	0.36	0.53	0.11	0.04	0.02	0.15	0.17	0.18	0.14	0.05	0.05	0.07
	12000	0.12	0.14	0.07	0.06	0.03	0.52	0.76	0.15	0.06	0.03	0.15	0.25	0.27	0.21	0.07	0.08	0.10

* Velocity exceeds 1000 fpm.
 ** Blender data based on Blender Products IV.

Table 6 continued: Component Pressure Drops (inches of water)

Unit Size	CFM	Dampers		F and BP face			F and BP by-pass			Plenum		Diffuser	Blender**			Attenuator		
		MXB	Econ.	Int. small	Int. med.	Large	Int. small	Int. med.	Large	Top/bot. inlet	Top/bot. outlet		One	Two	Three	3 ft	4 ft	5 ft
025	7300	0.03	0.04	0.02	0.02	0.01	0.07	0.10	0.05	0.02	0.01	0.15	0.06	0.05	0.06	0.02	0.02	0.02
	9800	0.06	0.07	0.04	0.03	0.01	0.13	0.17	0.08	0.03	0.01	0.15	0.12	0.10	0.10	0.03	0.04	0.05
	12200	0.09	0.11	0.06	0.05	0.02	0.21	0.27	0.13	0.05	0.02	0.15	0.18	0.15	0.16	0.05	0.06	0.07
	14600	0.13	0.15	0.09	0.07	0.02	0.30	0.38	0.18	0.07	0.03	0.15	0.26	0.22	0.22	0.07	0.09	0.11
030	8500	0.03	0.04	0.02	0.02	0.01	0.07	0.10	0.05	0.02	0.01	0.15	—	0.06	0.06	0.02	0.02	0.02
	11300	0.06	0.07	0.04	0.03	0.01	0.13	0.17	0.08	0.03	0.01	0.15	—	0.10	0.10	0.03	0.04	0.04
	14200	0.09	0.11	0.06	0.05	0.02	0.20	0.27	0.13	0.05	0.02	0.15	—	0.16	0.16	0.05	0.06	0.07
	17000	0.13	0.15	0.09	0.06	0.02	0.29	0.38	0.19	0.07	0.03	0.15	—	0.23	0.23	0.08	0.09	0.10
035	10000	0.03	0.04	0.02	0.02	0.01	0.08	0.10	0.05	0.02	0.01	0.15	—	0.07	0.06	0.02	0.02	0.02
	13400	0.06	0.07	0.03	0.03	0.01	0.15	0.17	0.09	0.03	0.02	0.15	—	0.12	0.11	0.04	0.04	0.04
	16700	0.09	0.10	0.05	0.05	0.02	0.23	0.27	0.14	0.05	0.02	0.15	—	0.18	0.16	0.06	0.06	0.07
	20000	0.13	0.15	0.06	0.07	0.02	0.33	0.38	0.20	0.07	0.03	0.15	—	0.26	0.24	0.08	0.09	0.11
045	13000	0.04	0.04	0.02	0.01	0.01	0.08	0.20	0.06	0.02	0.01	0.15	—	0.07	0.11	0.02	0.03	0.03
	17500	0.06	0.06	0.04	0.02	0.02	0.14	0.32	0.09	0.04	0.01	0.15	—	0.13	0.20	0.03	0.05	0.05
	22000	0.11	0.11	0.06	0.03	0.03	0.23	0.59	0.16	0.05	0.02	0.15	—	0.21	0.32	0.08	0.08	0.09
	26000	0.15	0.15	0.09	0.05	0.04	0.33	0.91	0.22	0.08	0.03	0.15	—	0.29	0.45	0.11	0.12	0.13
055	17000	0.04	0.04	0.02	0.01	0.01	0.08	0.22	0.05	0.02	0.01	0.15	—	0.10	0.21	0.03	0.03	0.04
	22000	0.06	0.06	0.05	0.02	0.02	0.15	0.30	0.10	0.05	0.02	0.15	—	0.14	0.35	0.04	0.06	0.06
	27000	0.11	0.11	0.06	0.03	0.03	0.23	0.62	0.17	0.06	0.03	0.15	—	0.25	0.27	0.08	0.09	0.10
	32000	0.14	0.14	0.09	0.04	0.04	0.31	0.87	0.23	0.09	0.03	0.15	—	0.29	0.37	0.12	0.13	0.14
065	19500	0.04	0.04	0.03	0.01	0.01	0.01	0.13	0.27	0.04	0.02	0.01	0.15	0.01	—	0.05	0.08	0.02
	26000	0.06	0.06	0.04	0.02	0.02	0.01	0.23	0.48	0.08	0.04	0.01	0.15	0.01	—	0.10	0.13	0.04
	32500	0.10	0.10	0.07	0.04	0.03	0.02	0.36	0.75	0.12	0.06	0.02	0.15	0.02	—	0.15	0.21	0.06
	39000	0.14	0.14	0.10	0.05	0.04	0.03	0.53	1.09	0.17	0.08	0.03	0.15	0.03	—	0.22	0.30	0.08
080	21500	0.03	0.03	—	0.02	0.01	0.01	0.09	0.16	0.04	0.02	0.01	0.15	0.01	—	0.07	0.10	0.02
	28700	0.05	0.05	—	0.03	0.02	0.01	0.17	0.29	0.08	0.03	0.01	0.15	0.01	—	0.12	0.17	0.04
	35900	0.08	0.08	—	0.05	0.04	0.02	0.26	0.45	0.12	0.05	0.02	0.15	0.02	—	0.19	0.27	0.07
	43100	0.11	0.11	—	0.07	0.05	0.03	0.37	0.65	0.18	0.07	0.03	0.15	0.03	—	0.28	0.38	0.10
085	23100	0.03	0.03	—	0.02	0.01	0.01	0.11	0.19	0.04	0.02	0.01	0.15	0.01	—	0.06	0.11	0.02
	30800	0.05	0.05	—	0.03	0.02	0.01	0.19	0.34	0.08	0.03	0.01	0.15	0.01	—	0.10	0.20	0.04
	38500	0.07	0.07	—	0.04	0.03	0.02	0.30	0.53	0.12	0.05	0.02	0.15	0.02	—	0.16	0.32	0.07
	46100	0.11	0.11	—	0.06	0.05	0.03	0.43	0.75	0.17	0.07	0.03	0.15	0.03	—	0.23	0.46	0.10
090	24600	0.03	0.03	—	0.01	0.01	0.01	0.13	0.22	0.04	0.02	0.01	0.15	0.01	—	0.07	0.13	0.02
	32800	0.05	0.05	—	0.02	0.02	0.01	0.22	0.39	0.08	0.03	0.01	0.15	0.01	—	0.12	0.24	0.04
	41000	0.08	0.08	—	0.04	0.03	0.02	0.35	0.60	0.12	0.05	0.02	0.15	0.02	—	0.19	0.37	0.07
	49200	0.11	0.11	—	0.06	0.04	0.03	0.50	0.87	0.17	0.07	0.03	0.15	0.03	—	0.27	—	0.10

*Velocity exceeds 1000 fpm.

**Blender data based on Blender Products IV.

Table 7: Filter Media Face Areas and Velocity Through Media

Unit Size	CFM	Filter Face Areas (sq ft) and Velocities (FPM)													
		2" Throwaway (TA)		2" Angular		4" Angular		12" Cartridge		4" Cartridge		12" Mini-Pleat		Bag	
		Area	Vel.	Area	Vel.	Area	Vel.	Area	Vel.	Area	Vel.	Area	Vel.	Area	Vel.
003	900	3.2	281	10.1	89	N/A	N/A	3.1	290	3.1	290	3.1	290	3.1	290
	1200	3.2	375	10.1	119	N/A	N/A	3.1	387	3.1	387	3.1	387	3.1	387
	1500	3.2	469	10.1	149	N/A	N/A	3.1	484	3.1	484	3.1	484	3.1	484
	1800	3.2	563	10.1	178	N/A	N/A	3.1	581	3.1	581	3.1	581	3.1	581
004	1200	5.7	211	11.4	105	N/A	N/A	5.6	214	5.6	214	5.6	214	5.6	214
	1600	5.7	281	11.4	140	N/A	N/A	5.6	286	5.6	286	5.6	286	5.6	286
	2000	5.7	351	11.4	175	N/A	N/A	5.6	357	5.6	357	5.6	357	5.6	357
	2400	5.7	421	11.4	211	N/A	N/A	5.6	429	5.6	429	5.6	429	5.6	429
006	1700	7.6	224	15.3	111	N/A	N/A	7.6	224	7.6	224	7.6	224	7.6	224
	2300	7.6	303	15.3	150	N/A	N/A	7.6	303	7.6	303	7.6	303	7.6	303
	2900	7.6	382	15.3	190	N/A	N/A	7.6	382	7.6	382	7.6	382	7.6	382
	3500	7.6	461	15.3	229	N/A	N/A	7.6	461	7.6	461	7.6	461	7.6	461
008	2200	8.8	250	17.7	124	17.7	124	8.1	272	8.1	272	8.1	272	8.1	272
	3000	8.8	341	17.7	169	17.7	169	8.1	370	8.1	370	8.1	370	8.1	370
	3800	8.8	432	17.7	215	17.7	215	8.1	469	8.1	469	8.1	469	8.1	469
	4600	8.8	523	17.7	260	17.7	260	8.1	568	8.1	568	8.1	568	8.1	568
010	2900	10.0	289	19.0	153	19.0	153	10.0	290	10.0	290	10.0	290	10.0	290
	3900	10.0	389	19.0	205	19.0	205	10.0	391	10.0	391	10.0	391	10.0	391
	4900	10.0	489	19.0	258	19.0	258	10.0	491	10.0	491	10.0	491	10.0	491
	5900	10.0	589	19.0	311	19.0	311	10.0	591	10.0	591	10.0	591	10.0	591
012	3600	13.2	273	30.3	119	20.3	177	13.1	275	13.1	275	13.1	275	13.1	275
	4800	13.2	364	30.3	159	20.3	236	13.1	366	13.1	366	13.1	366	13.1	366
	6000	13.2	455	30.3	198	20.3	296	13.1	458	13.1	458	13.1	458	13.1	458
	7200	13.2	545	30.3	238	20.3	355	13.1	550	13.1	550	13.1	550	13.1	550
014	4200	17.0	247	34.1	123	22.9	183	14.4	292	14.4	292	14.4	292	14.4	292
	5400	17.0	318	34.1	158	22.9	236	14.4	375	14.4	375	14.4	375	14.4	375
	6600	17.0	388	34.1	193	22.9	288	14.4	458	14.4	458	14.4	458	14.4	458
	8800	17.0	518	34.1	258	22.9	384	14.4	611	14.4	611	14.4	611	14.4	611
017	5000	19.0	263	35.7	140	36.0	139	18.9	265	18.9	265	18.9	265	18.9	265
	6700	19.0	353	36.0	186	36.0	186	18.9	354	18.9	354	18.9	354	18.9	354
	8400	19.0	442	36.0	233	36.0	233	18.9	444	18.9	444	18.9	444	18.9	444
	10100	19.0	532	36.0	281	36.0	281	18.9	534	18.9	534	18.9	534	18.9	534
021	6000	23.2	259	38.0	158	38.0	158	23.0	261	23.0	261	20.8	288	23.0	281
	8000	23.2	345	38.0	211	38.0	211	23.0	348	23.0	348	20.8	385	23.0	348
	10000	23.2	431	38.0	263	38.0	263	23.0	435	23.0	435	20.8	481	23.0	435
	12000	23.2	517	38.0	316	38.0	316	23.0	522	23.0	522	20.8	577	23.0	522
025	7300	26.6	274	39.9	183	39.9	183	26.5	275	26.5	275	26.5	275	26.5	275
	9800	26.6	368	39.9	246	39.9	246	26.5	370	26.5	370	26.5	370	26.5	370
	12200	26.6	459	39.9	306	39.9	306	26.5	460	26.5	460	26.5	460	26.5	460
	14600	26.6	549	39.9	366	39.9	366	26.5	551	26.5	551	26.5	551	26.5	551

Note: 400 fpm maximum for angular filters.

Table 7 continued: Filter Media Face Areas and Velocity Through Media

Unit Size	CFM	Filter Face Areas (sq ft) and Velocities (FPM)													
		2" Throwaway (TA)		2" Angular		4" Angular		12" Cartridge		4" Cartridge		12" Mini-Pleat		Bag	
		Area	Vel.	Area	Vel.	Area	Vel.	Area	Vel.	Area	Vel.	Area	Vel.	Area	Vel.
030	8500	32.8	269	45.8	186	45.8	186	32.6	261	32.6	261	32.6	261	32.6	261
	11300	32.8	345	45.8	247	45.8	247	32.6	347	32.6	347	32.6	347	32.6	347
	14200	32.8	433	45.8	310	45.8	310	32.6	436	32.6	436	32.6	436	32.6	436
	17000	32.8	578	45.8	371	45.8	371	32.6	521	32.6	521	32.6	521	32.6	521
035	10000	39.4	254	63.3	158	63.3	158	39.1	256	39.1	256	37.7	265	39.1	256
	13400	39.4	340	63.3	212	63.3	212	39.1	343	39.1	343	37.7	355	39.1	343
	16700	39.4	424	63.3	264	63.3	264	39.1	427	39.1	427	37.7	443	39.1	427
	20000	39.4	508	63.3	316	63.3	316	39.1	512	39.1	512	37.7	531	39.1	512
045	13000	49.4	263	65.5	198	65.5	198	49.1	265	49.1	265	49.1	265	49.1	265
	17500	49.4	354	65.5	267	65.5	267	49.1	356	49.1	356	49.1	356	49.1	356
	22000	49.4	445	65.5	336	65.5	336	49.1	448	49.1	448	49.1	448	49.1	448
	26000	49.4	526	65.5	397	65.5	397	49.1	529	49.1	529	49.1	529	49.1	529
055	17000	57.5	296	81.9	208	81.9	208	54.8	310	57.1	298	54.7	311	57.1	298
	22000	57.5	383	81.9	269	81.9	269	54.8	401	57.1	385	54.7	402	57.1	385
	27000	57.5	470	81.9	330	81.9	330	54.8	492	57.1	473	54.7	494	57.1	473
	32000	57.5	557	81.9	391	81.9	391	54.8	584	57.1	560	54.7	585	57.1	560
065	19500	72.1	270	107.5	181	107.5	181	71.7	272	71.7	272	71.7	272	71.7	272
	26000	72.1	361	107.5	242	107.5	242	71.7	363	71.7	363	71.7	363	71.7	363
	32500	72.1	451	107.5	302	107.5	302	71.7	453	71.7	453	71.7	453	71.7	453
	39000	72.1	541	107.5	363	107.5	363	71.7	544	71.7	544	71.7	544	71.7	544
080	21500	80.2	268	107.5	200	107.5	200	78.2	275	79.7	270	78.2	275	79.7	270
	28700	80.2	358	107.5	267	107.5	267	78.2	367	79.7	360	78.2	367	79.7	360
	35900	80.2	448	107.5	334	107.5	334	78.2	459	79.7	450	78.2	459	79.7	450
	43100	80.2	538	107.5	401	107.5	401	78.2	551	79.7	541	78.2	551	79.7	541
085	23100	86.0	269	129.0	179	107.5	215	83.3	277	83.3	277	83.3	277	83.3	277
	30800	86.0	358	129.0	239	107.5	287	83.3	370	83.3	370	83.3	370	83.3	370
	38500	86.0	448	129.0	298	107.5	359	83.3	462	83.3	462	83.3	462	83.3	462
	46100	86.0	536	129.0	358	129.0	358	83.3	553	83.3	554	83.3	554	83.3	554
090	24600	90.4	272	129.0	191	129.0	191	86.3	285	89.8	274	87.4	281	89.8	274
	32800	90.4	363	129.0	254	129.0	254	86.3	380	89.8	365	87.4	375	89.8	365
	41000	90.4	454	129.0	318	129.0	318	86.3	475	89.8	456	87.4	469	89.8	456
	49200	90.4	544	129.0	381	129.0	381	86.3	570	89.8	548	87.4	563	89.8	548

Note: 400 fpm maximum for angular filters.

Table 8: Filter Media Air Pressure Drop Based on Clean Filters—Flat and Angular Panel, High Efficiency Cartridge

Unit Size	CFM	Flat Panel					Angular Panel					High Efficiency Cartridge								
		T.A.	Pleated (30%)		Pleated (70%)		T.A.	Pleated (30%)		Pleated (70%)		Cartridge			Mini-Pleat Cartridge					
		2"	2"	4"	2"	4"	2"	2"	4"	2"	4"	12"			4"			12"		
		N/A	30%	30%	70%	70%	N/A	30%	30%	70%	70%	65%	85%	95%	65%	85%	95%	65%	85%	95%
003	900	0.11	0.12	0.11	0.15	0.12	0.02	0.01	—	0.03	—	0.18	0.25	0.26	0.18	0.31	0.36	0.10	0.13	0.22
	1200	0.17	0.19	0.16	0.21	0.18	0.03	0.02	—	0.05	—	0.27	0.38	0.40	0.28	0.44	0.51	0.18	0.22	0.34
	1500	0.23	0.27	0.23	0.29	0.25	0.04	0.03	—	0.06	—	0.37	0.53	0.55	0.40	0.58	0.66	0.27	0.34	0.47
	1800	0.30	0.37	0.31	0.37	0.33	0.05	0.04	—	0.08	—	0.48	0.70	0.72	0.53	0.72	0.82	0.39	0.47	0.61
004	1200	0.07	0.07	0.07	0.10	0.08	0.03	0.02	—	0.04	—	0.12	0.16	0.16	0.11	0.22	0.26	0.06	0.08	0.14
	1600	0.11	0.11	0.10	0.15	0.12	0.04	0.04	—	0.06	—	0.18	0.25	0.25	0.18	0.31	0.36	0.10	0.13	0.22
	2000	0.15	0.17	0.15	0.20	0.17	0.06	0.05	—	0.08	—	0.24	0.34	0.35	0.25	0.40	0.47	0.15	0.19	0.30
	2400	0.20	0.23	0.20	0.25	0.22	0.07	0.07	—	0.10	—	0.31	0.45	0.46	0.33	0.50	0.58	0.22	0.27	0.39
006	1700	0.08	0.08	0.07	0.11	0.09	0.03	0.02	—	0.04	—	0.12	0.17	0.17	0.12	0.23	0.27	0.06	0.08	0.15
	2300	0.12	0.13	0.12	0.16	0.13	0.04	0.04	—	0.06	—	0.19	0.27	0.27	0.20	0.33	0.39	0.11	0.14	0.23
	2900	0.17	0.19	0.17	0.22	0.18	0.06	0.06	—	0.09	—	0.26	0.38	0.39	0.28	0.44	0.51	0.17	0.22	0.33
	3500	0.22	0.26	0.22	0.28	0.24	0.08	0.08	—	0.11	—	0.35	0.50	0.51	0.38	0.55	0.64	0.25	0.31	0.43
008	2200	0.09	0.09	0.09	0.12	0.10	0.03	0.03	0.03	0.05	0.04	0.15	0.21	0.21	0.17	0.29	0.34	0.08	0.10	0.18
	3000	0.14	0.16	0.14	0.19	0.16	0.05	0.05	0.05	0.07	0.06	0.23	0.32	0.33	0.27	0.42	0.49	0.14	0.18	0.28
	3800	0.20	0.24	0.20	0.25	0.22	0.07	0.07	0.07	0.10	0.08	0.32	0.46	0.47	0.39	0.56	0.65	0.22	0.28	0.40
	4600	0.27	0.33	0.27	0.33	0.29	0.10	0.10	0.09	0.13	0.11	0.42	0.61	0.63	0.52	0.71	0.81	0.32	0.40	0.53
010	2900	0.12	0.13	0.12	0.16	0.14	0.05	0.04	0.04	0.07	0.05	0.20	0.28	0.28	0.20	0.34	0.40	0.11	0.15	0.24
	3900	0.19	0.22	0.19	0.24	0.21	0.07	0.07	0.06	0.10	0.08	0.30	0.43	0.44	0.32	0.48	0.56	0.20	0.26	0.37
	4900	0.26	0.32	0.27	0.32	0.28	0.10	0.10	0.09	0.13	0.11	0.41	0.60	0.62	0.46	0.64	0.73	0.31	0.39	0.52
	5900	0.34	0.44	0.36	0.41	0.37	0.13	0.14	0.12	0.17	0.14	0.54	0.78	0.81	0.61	0.80	0.91	0.45	0.55	0.68
012	3600	0.13	0.14	0.13	0.14	0.12	0.06	0.05	0.05	0.08	0.06	0.17	0.23	0.24	0.17	0.29	0.35	0.09	0.12	0.20
	4800	0.20	0.23	0.20	0.20	0.17	0.09	0.09	0.08	0.12	0.09	0.25	0.35	0.36	0.26	0.42	0.49	0.16	0.20	0.31
	6000	0.27	0.33	0.28	0.27	0.24	0.12	0.13	0.11	0.16	0.13	0.34	0.49	0.51	0.37	0.55	0.63	0.25	0.31	0.43
	7200	—	—	—	0.35	0.31	0.15	0.17	0.15	0.20	0.17	0.45	0.64	0.67	0.50	0.68	0.78	0.35	0.43	0.56
014	4200	0.09	0.09	0.09	0.12	0.10	0.06	0.06	0.05	0.08	0.07	0.17	0.24	0.24	0.19	0.32	0.37	0.10	0.12	0.21
	5400	0.13	0.14	0.13	0.17	0.14	0.08	0.09	0.08	0.12	0.09	0.24	0.35	0.36	0.27	0.43	0.50	0.15	0.20	0.30
	6600	0.17	0.20	0.17	0.22	0.19	0.11	0.12	0.11	0.15	0.13	0.32	0.46	0.48	0.37	0.55	0.63	0.23	0.28	0.41
	8800	0.26	0.32	0.27	0.32	0.29	0.17	0.19	0.17	0.22	0.19	0.41	0.59	0.61	0.59	0.78	0.88	0.39	0.48	0.62
017	5000	0.10	0.10	0.10	0.13	0.11	0.04	0.04	0.04	0.06	0.04	0.16	0.22	0.22	0.16	0.28	0.33	0.09	0.11	0.19
	6700	0.15	0.17	0.15	0.20	0.17	0.06	0.06	0.06	0.08	0.07	0.24	0.34	0.35	0.25	0.40	0.47	0.15	0.19	0.30
	8400	0.21	0.25	0.21	0.26	0.23	0.08	0.08	0.08	0.11	0.09	0.33	0.47	0.49	0.36	0.53	0.61	0.23	0.29	0.41
	10100	0.27	0.34	0.28	0.33	0.30	0.11	0.11	0.11	0.14	0.12	0.43	0.62	0.64	0.48	0.66	0.76	0.33	0.41	0.54
021	6000	0.10	0.10	0.09	0.13	0.11	0.05	0.04	0.04	0.07	0.05	0.15	0.22	0.22	0.16	0.28	0.33	0.10	0.13	0.22
	8000	0.15	0.16	0.14	0.19	0.16	0.07	0.07	0.07	0.10	0.08	0.23	0.33	0.34	0.24	0.39	0.46	0.18	0.22	0.33
	10000	0.20	0.24	0.20	0.25	0.22	0.10	0.10	0.10	0.13	0.11	0.32	0.46	0.47	0.35	0.51	0.59	0.27	0.33	0.46
	12000	0.26	0.32	0.27	0.32	0.29	0.13	0.14	0.13	0.17	0.14	0.41	0.60	0.62	0.46	0.64	0.74	0.38	0.47	0.60

Note: 400 fpm maximum for angular filters.

Table 8 continued: Filter Media Air Pressure Drop Based on Clean Filters—Flat and Angular Panel, High Efficiency Cartridge

Unit Size	CFM	Flat Panel					Angular Panel					High Efficiency Cartridge								
		T.A.	Pleated (30%)		Pleated (70%)		T.A.	Pleated (30%)		Pleated (70%)		Cartridge			Mini-Pleat Cartridge					
		2"	2"	4"	2"	4"	2"	2"	4"	2"	4"	12"			4"			12"		
		N/A	30%	30%	70%	70%	N/A	30%	30%	70%	70%	65%	85%	95%	65%	85%	95%	65%	85%	95%
025	7300	0.11	0.11	0.10	0.14	0.12	0.06	0.06	0.05	0.08	0.07	0.17	0.23	0.24	0.17	0.30	0.35	0.09	0.12	0.20
	9800	0.16	0.18	0.16	0.21	0.18	0.09	0.09	0.09	0.12	0.10	0.25	0.36	0.37	0.27	0.42	0.49	0.16	0.21	0.31
	12200	0.22	0.26	0.22	0.28	0.24	0.12	0.13	0.12	0.16	0.14	0.35	0.50	0.51	0.38	0.55	0.64	0.25	0.31	0.43
	14600	0.29	0.35	0.29	0.35	0.31	0.16	0.18	0.16	0.20	0.18	0.45	0.65	0.67	0.50	0.69	0.79	0.35	0.43	0.57
030	8500	0.10	0.10	0.09	0.13	0.11	0.06	0.06	0.06	0.08	0.07	0.15	0.22	0.22	0.16	0.28	0.33	0.08	0.11	0.19
	11300	0.15	0.16	0.14	0.19	0.16	0.09	0.09	0.09	0.12	0.10	0.23	0.33	0.34	0.24	0.39	0.46	0.14	0.18	0.29
	14200	0.20	0.24	0.20	0.26	0.22	0.13	0.14	0.12	0.16	0.14	0.32	0.46	0.47	0.35	0.52	0.60	0.22	0.28	0.40
035	17000	0.26	0.32	0.27	0.32	0.29	0.16	0.18	0.16	0.21	0.18	0.41	0.60	0.62	0.46	0.64	0.74	0.32	0.39	0.52
	10000	0.09	0.10	0.09	0.13	0.10	0.05	0.04	0.04	0.07	0.05	0.15	0.21	0.21	0.15	0.27	0.32	0.09	0.11	0.19
	13400	0.14	0.16	0.14	0.19	0.16	0.07	0.07	0.07	0.10	0.08	0.23	0.32	0.33	0.24	0.39	0.45	0.15	0.19	0.30
	16700	0.20	0.23	0.20	0.25	0.22	0.10	0.10	0.10	0.13	0.11	0.31	0.44	0.46	0.34	0.50	0.58	0.23	0.29	0.41
045	20000	0.26	0.31	0.26	0.32	0.28	0.13	0.14	0.13	0.17	0.14	0.40	0.58	0.60	0.45	0.63	0.72	0.32	0.40	0.53
	13000	0.11	0.06	0.10	0.14	0.12	0.07	0.04	0.07	0.10	0.08	0.16	0.23	0.24	0.17	0.29	0.34	0.12	0.16	0.24
	17500	0.16	0.11	0.16	0.21	0.18	0.11	0.07	0.10	0.14	0.12	0.25	0.34	0.36	0.26	0.42	0.43	0.18	0.27	0.36
	22000	0.22	0.15	0.22	0.26	0.23	0.14	0.09	0.14	0.18	0.15	0.34	0.51	0.50	0.37	0.54	0.63	0.28	0.32	0.50
055	26000	0.29	0.22	0.30	0.31	0.31	0.18	0.12	0.18	0.23	0.20	0.44	0.67	0.54	0.49	0.67	0.78	0.43	0.48	0.65
	17000	0.12	0.07	0.11	0.16	0.13	0.07	0.04	0.07	0.10	0.08	0.16	0.22	0.24	0.18	0.30	0.35	0.14	0.17	0.22
	22000	0.17	0.11	0.16	0.22	0.19	0.11	0.08	0.10	0.14	0.12	0.24	0.34	0.35	0.26	0.44	0.43	0.19	0.25	0.32
	27000	0.22	0.14	0.23	0.28	0.25	0.15	0.10	0.15	0.18	0.16	0.34	0.50	0.50	0.38	0.54	0.65	0.28	0.35	0.44
065	32000	0.29	0.23	0.30	0.36	0.32	0.17	0.12	0.17	0.22	0.19	0.45	0.67	0.55	0.49	0.68	0.79	0.45	0.49	0.67
	19500	0.11	0.11	0.10	0.13	0.11	0.06	0.06	0.05	0.08	0.06	0.17	0.24	0.25	0.16	0.29	0.34	0.11	0.14	0.23
	26000	0.16	0.19	0.16	0.19	0.16	0.09	0.09	0.08	0.12	0.10	0.26	0.37	0.38	0.26	0.41	0.47	0.18	0.23	0.34
	32500	0.23	0.27	0.23	0.25	0.22	0.12	0.13	0.12	0.16	0.13	0.36	0.51	0.53	0.36	0.53	0.62	0.28	0.35	0.48
080	39000	0.30	0.37	0.30	0.32	0.29	0.16	0.18	0.16	0.20	0.17	0.46	0.67	0.70	0.48	0.67	0.76	0.40	0.49	0.62
	21500	0.10	0.06	0.09	0.13	0.11	0.07	0.04	0.06	0.09	0.07	0.17	0.23	0.24	0.17	0.29	0.34	0.09	0.12	0.20
	28700	0.15	0.10	0.15	0.19	0.16	0.10	0.06	0.10	0.13	0.11	0.25	0.36	0.37	0.26	0.41	0.48	0.16	0.20	0.31
	35900	0.21	0.15	0.21	0.26	0.22	0.14	0.09	0.14	0.18	0.15	0.35	0.49	0.51	0.37	0.54	0.62	0.25	0.31	0.43
085	43100	0.28	0.20	0.27	0.33	0.29	0.18	0.13	0.18	0.23	0.20	0.45	0.65	0.67	0.49	0.67	0.77	0.35	0.43	0.57
	23100	0.10	0.06	0.10	0.14	0.11	0.06	0.03	0.07	0.08	0.08	0.17	0.24	0.24	0.17	0.30	0.35	0.09	0.12	0.21
	30800	0.15	0.10	0.15	0.20	0.17	0.09	0.05	0.11	0.12	0.12	0.25	0.36	0.37	0.27	0.42	0.49	0.16	0.21	0.31
	38500	0.21	0.15	0.22	0.27	0.23	0.12	0.07	0.15	0.16	0.17	0.35	0.50	0.52	0.38	0.55	0.64	0.25	0.31	0.44
090	46100	0.28	0.21	0.28	0.34	0.30	0.15	0.10	0.15	0.20	0.17	0.45	0.65	0.67	0.50	0.69	0.79	0.35	0.43	0.57
	24600	0.10	0.06	0.10	0.13	0.11	0.06	0.03	0.06	0.09	0.07	0.17	0.25	0.25	0.17	0.29	0.35	0.10	0.13	0.21
	32800	0.16	0.10	0.15	0.19	0.17	0.09	0.06	0.09	0.13	0.10	0.26	0.37	0.39	0.26	0.42	0.48	0.17	0.21	0.32
	41000	0.22	0.15	0.21	0.26	0.23	0.13	0.08	0.13	0.17	0.14	0.36	0.52	0.54	0.37	0.55	0.63	0.26	0.32	0.45
49200	0.28	0.21	0.28	0.33	0.29	0.17	0.12	0.17	0.22	0.18	0.47	0.68	0.71	0.50	0.68	0.78	0.36	0.45	0.58	

Note: 400 fpm maximum for angular filters.

Table 9: Filter Media Air Pressure Drop Based on Clean Filters—High Efficiency Bag

Unit Size	CFM	High Efficiency Bag											
		DriPak 2000											
		36"			30"			22"			19"	15"	12"
		65%	85%	95%	65%	85%	95%	65%	85%	95%	45%	45%	45%
003	900	0.15	0.22	0.29	0.15	0.21	0.32	0.17	0.28	0.42	0.11	0.10	0.13
	1200	0.20	0.29	0.39	0.19	0.29	0.43	0.23	0.37	0.56	0.18	0.14	0.17
	1500	0.24	0.36	0.49	0.24	0.36	0.53	0.28	0.46	0.70	0.25	0.19	0.21
	1800	0.29	0.43	0.59	0.29	0.43	0.64	0.33	0.56	0.83	0.33	0.24	0.25
004	1200	0.11	0.16	0.21	0.11	0.16	0.24	0.13	0.21	0.32	0.07	0.07	0.10
	1600	0.15	0.21	0.29	0.14	0.21	0.31	0.17	0.27	0.42	0.11	0.10	0.13
	2000	0.18	0.27	0.36	0.18	0.26	0.39	0.21	0.34	0.52	0.16	0.13	0.16
	2400	0.22	0.32	0.44	0.21	0.32	0.47	0.25	0.41	0.62	0.21	0.16	0.19
006	1700	0.12	0.17	0.22	0.11	0.17	0.25	0.14	0.21	0.33	0.08	0.07	0.11
	2300	0.15	0.23	0.31	0.15	0.22	0.33	0.18	0.29	0.44	0.12	0.11	0.14
	2900	0.19	0.28	0.39	0.19	0.28	0.42	0.22	0.37	0.55	0.17	0.14	0.17
	3500	0.23	0.34	0.47	0.23	0.34	0.51	0.27	0.44	0.66	0.23	0.18	0.20
008	2200	0.13	0.19	0.25	0.13	0.19	0.28	0.15	0.24	0.37	0.09	0.08	0.12
	3000	0.17	0.26	0.35	0.17	0.26	0.38	0.20	0.33	0.50	0.15	0.13	0.16
	3800	0.22	0.32	0.44	0.22	0.32	0.48	0.26	0.42	0.63	0.21	0.17	0.19
	4600	0.26	0.39	0.54	0.26	0.39	0.58	0.31	0.51	0.76	0.28	0.21	0.23
010	2900	0.16	0.23	0.31	0.15	0.23	0.34	0.18	0.30	0.45	0.13	0.11	0.14
	3900	0.21	0.31	0.42	0.21	0.31	0.46	0.24	0.40	0.60	0.20	0.16	0.19
	4900	0.26	0.39	0.53	0.26	0.39	0.57	0.30	0.50	0.75	0.28	0.21	0.23
	5900	—	—	—	—	—	—	—	—	—	—	—	—
012	3600	0.14	0.21	0.28	0.14	0.20	0.30	0.16	0.26	0.40	0.11	0.09	0.13
	4800	0.19	0.27	0.37	0.18	0.27	0.40	0.22	0.35	0.53	0.16	0.14	0.17
	6000	0.23	0.34	0.47	0.23	0.34	0.50	0.27	0.44	0.66	0.23	0.18	0.20
	7200	0.27	0.41	0.56	0.27	0.41	0.60	0.32	0.53	0.79	0.30	0.23	0.24
014	4200	0.14	0.21	0.28	0.14	0.21	0.31	0.17	0.27	0.41	0.11	0.10	0.13
	5400	0.18	0.27	0.36	0.18	0.27	0.40	0.21	0.35	0.52	0.16	0.13	0.16
	6600	0.22	0.33	0.45	0.22	0.33	0.48	0.26	0.42	0.64	0.21	0.17	0.20
	8800	0.29	0.43	0.60	0.29	0.43	0.65	0.34	0.56	0.84	0.33	0.24	0.25
017	5000	0.14	0.20	0.27	0.13	0.20	0.29	0.16	0.25	0.39	0.10	0.09	0.12
	6700	0.18	0.26	0.36	0.18	0.26	0.39	0.21	0.34	0.52	0.15	0.13	0.16
	8400	0.22	0.33	0.45	0.22	0.33	0.49	0.26	0.43	0.64	0.22	0.17	0.20
	10100	0.27	0.39	0.55	0.27	0.40	0.59	0.31	0.51	0.77	0.29	0.22	0.23
021	6000	0.13	0.20	0.26	0.13	0.19	0.29	0.16	0.25	0.38	0.10	0.09	0.12
	8000	0.18	0.26	0.35	0.17	0.26	0.38	0.21	0.33	0.51	0.15	0.13	0.16
	10000	0.22	0.32	0.44	0.22	0.32	0.48	0.25	0.42	0.63	0.21	0.17	0.19
	12000	0.26	0.39	0.53	0.26	0.39	0.57	0.30	0.50	0.75	0.28	0.21	0.23
025	7300	0.14	0.21	0.28	0.14	0.20	0.30	0.16	0.26	0.40	0.11	0.09	0.13
	9800	0.19	0.28	0.37	0.18	0.27	0.41	0.22	0.36	0.54	0.16	0.14	0.17
	12200	0.23	0.34	0.47	0.23	0.34	0.51	0.27	0.44	0.66	0.23	0.18	0.20
	14600	0.27	0.41	0.56	0.28	0.41	0.61	0.32	0.53	0.79	0.30	0.23	0.24

Table 9 continued: Filter Media Air Pressure Drop Based on Clean Filters—High Efficiency Bag

Unit Size	CFM	High Efficiency Bag											
		DriPak 2000											
		36"			30"			22"			19"	15"	12"
		65%	85%	95%	65%	85%	95%	65%	85%	95%	45%	45%	45%
030	8500	0.13	0.20	0.26	0.13	0.19	0.29	0.16	0.25	0.38	0.10	0.09	0.12
	11300	0.18	0.26	0.35	0.17	0.26	0.38	0.21	0.33	0.51	0.15	0.13	0.16
	14200	0.22	0.32	0.44	0.22	0.32	0.48	0.26	0.42	0.63	0.21	0.17	0.19
	17000	0.26	0.39	0.53	0.26	0.39	0.58	0.30	0.50	0.75	0.28	0.21	0.23
035	10000	0.13	0.19	0.26	0.13	0.19	0.28	0.15	0.25	0.38	0.09	0.09	0.12
	13400	0.17	0.26	0.35	0.17	0.25	0.38	0.20	0.33	0.50	0.15	0.12	0.16
	16700	0.21	0.32	0.43	0.21	0.32	0.47	0.25	0.41	0.62	0.20	0.16	0.19
	20000	0.26	0.38	0.52	0.26	0.38	0.56	0.30	0.49	0.74	0.27	0.21	0.22
045	13000	0.14	0.19	0.27	0.14	0.20	0.31	0.16	0.26	0.40	0.10	0.09	0.13
	17500	0.19	0.27	0.37	0.18	0.26	0.40	0.21	0.35	0.52	0.16	0.13	0.16
	22000	0.24	0.32	0.46	0.23	0.34	0.50	0.27	0.43	0.65	0.23	0.19	0.21
	26000	0.28	0.40	0.55	0.27	0.41	0.60	0.31	0.51	0.79	0.29	0.22	0.23
055	17000	0.15	0.20	0.28	0.13	0.20	0.30	0.17	0.27	0.41	0.11	0.10	0.13
	22000	0.18	0.28	0.38	0.19	0.27	0.41	0.22	0.34	0.53	0.17	0.12	0.16
	27000	0.23	0.33	0.45	0.24	0.35	0.51	0.26	0.43	0.67	0.24	0.17	0.21
	32000	0.28	0.41	0.57	0.28	0.40	0.61	0.30	0.52	0.78	0.30	0.23	0.24
065	19500	0.14	0.21	0.28	0.14	0.21	0.31	0.17	0.27	0.41	0.11	0.10	0.13
	26000	0.19	0.28	0.38	0.19	0.28	0.41	0.22	0.36	0.55	0.17	0.14	0.17
	32500	0.24	0.35	0.48	0.24	0.35	0.52	0.27	0.45	0.68	0.24	0.19	0.21
	39000	0.28	0.42	0.58	0.28	0.42	0.62	0.33	0.54	0.81	0.31	0.23	0.25
080	21500	0.12	0.16	0.23	0.15	0.19	0.27	0.17	0.26	0.38	0.07	0.09	0.13
	28700	0.15	0.21	0.31	0.19	0.26	0.36	0.22	0.35	0.51	0.11	0.13	0.16
	35900	0.19	0.26	0.39	0.24	0.32	0.45	0.27	0.43	0.63	0.16	0.18	0.20
	43100	0.23	0.31	0.47	0.28	0.39	0.54	0.32	0.52	0.76	0.21	0.22	0.24
085	23100	0.12	0.16	0.23	0.15	0.20	0.28	0.17	0.27	0.40	0.08	0.10	0.13
	30800	0.16	0.22	0.32	0.20	0.27	0.37	0.23	0.36	0.52	0.12	0.14	0.17
	38500	0.19	0.27	0.40	0.24	0.33	0.46	0.28	0.44	0.65	0.16	0.18	0.21
	46100	0.23	0.32	0.48	0.29	0.40	0.55	0.33	0.53	0.77	0.22	0.23	0.24
090	24600	0.12	0.16	0.23	0.15	0.20	0.28	0.17	0.26	0.39	0.07	0.09	0.13
	32800	0.16	0.21	0.31	0.20	0.26	0.37	0.22	0.35	0.52	0.12	0.13	0.17
	41000	0.19	0.27	0.39	0.24	0.33	0.46	0.28	0.44	0.64	0.16	0.18	0.20
	49200	0.23	0.32	0.47	0.28	0.39	0.55	0.33	0.53	0.76	0.21	0.22	0.24

Figure 19: Coil Air Pressure Drop—HI-F5 Fin Type (2 Through 12 Rows)

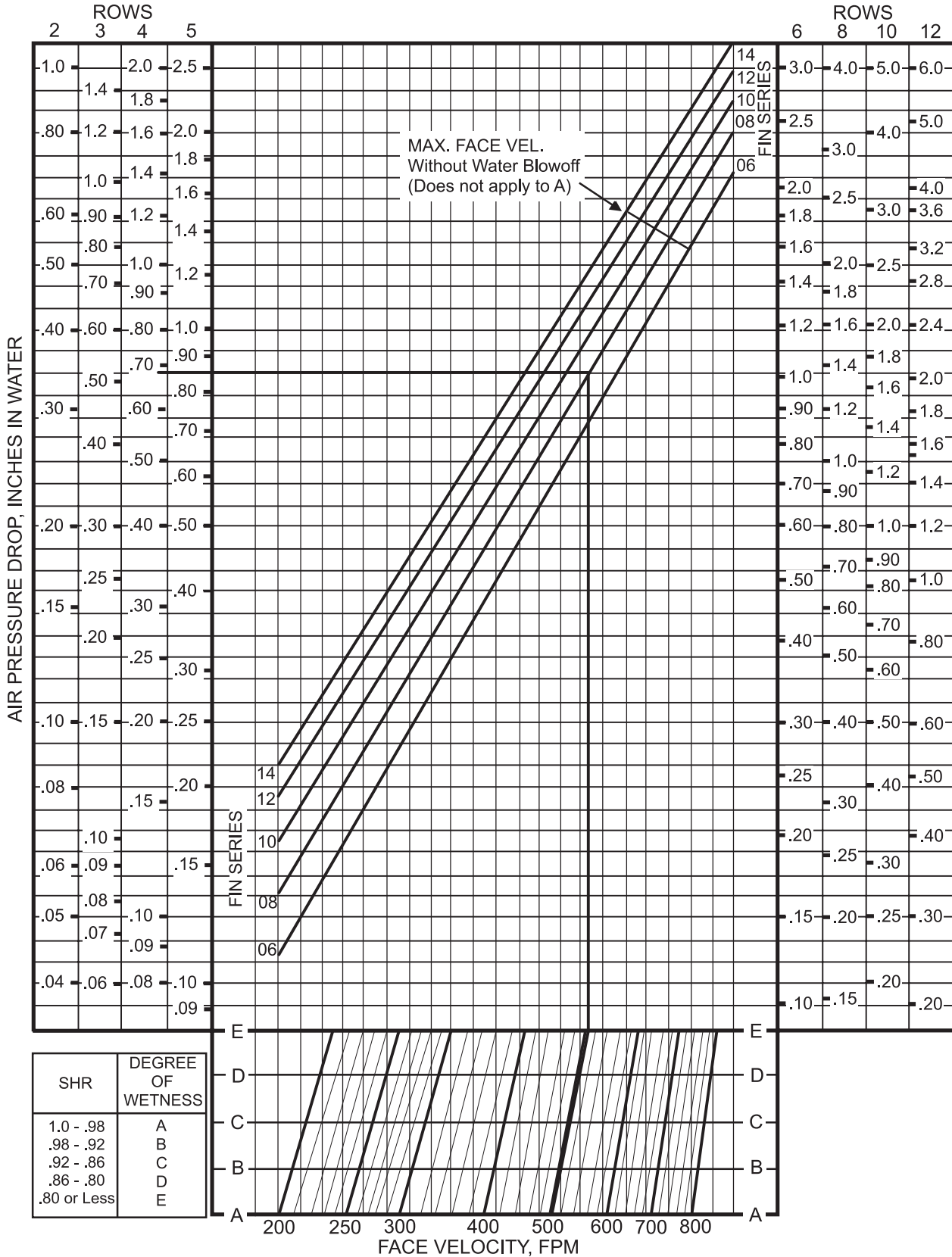

- Notes:
- The letters A,B,C,D or E following the face velocity indicate the degree of wetness at which the coil is operating.
 - Dry coils are shown by the letter A, wet coils by the letter E. Intermediate conditions are shown by the letters B, C, and D.
 - Air pressure drop for odd fin spacings can be found by interpolation.

Figure 20: Coil Air Pressure Drop—E-F5 Fin Type (2 Through 12 Rows)

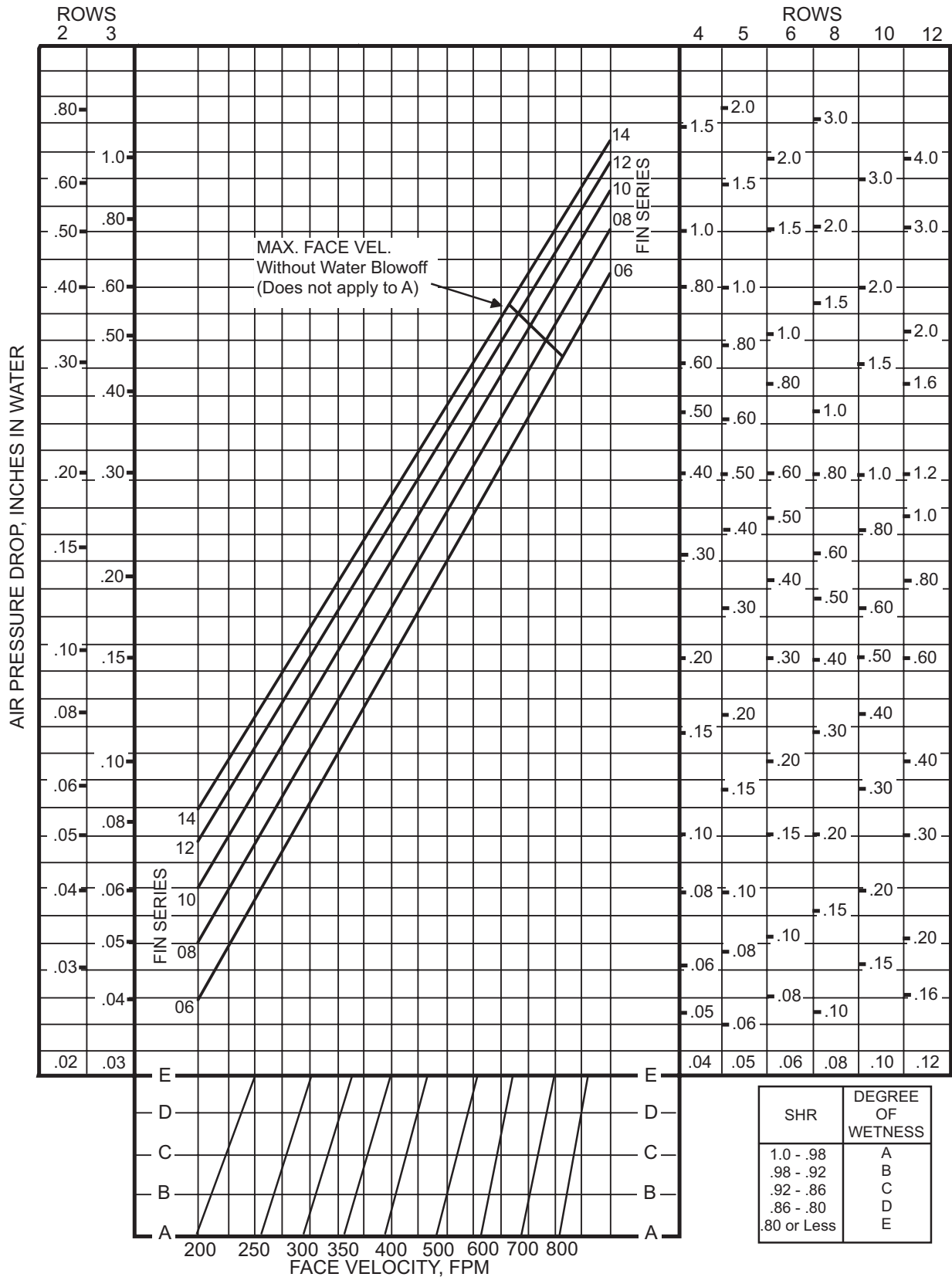

- Notes:
- The letters A,B,C,D or E following the face velocity indicate the degree of wetness at which the coil is operating.
 - Dry coils are shown by the letter A, wet coils by the letter E. Intermediate conditions are shown by the letters B, C, and D.
 - Air pressure drop for odd fin spacings can be found by interpolation.

Figure 21: Coil Air Pressure Drop—HI-F5 Fin Type

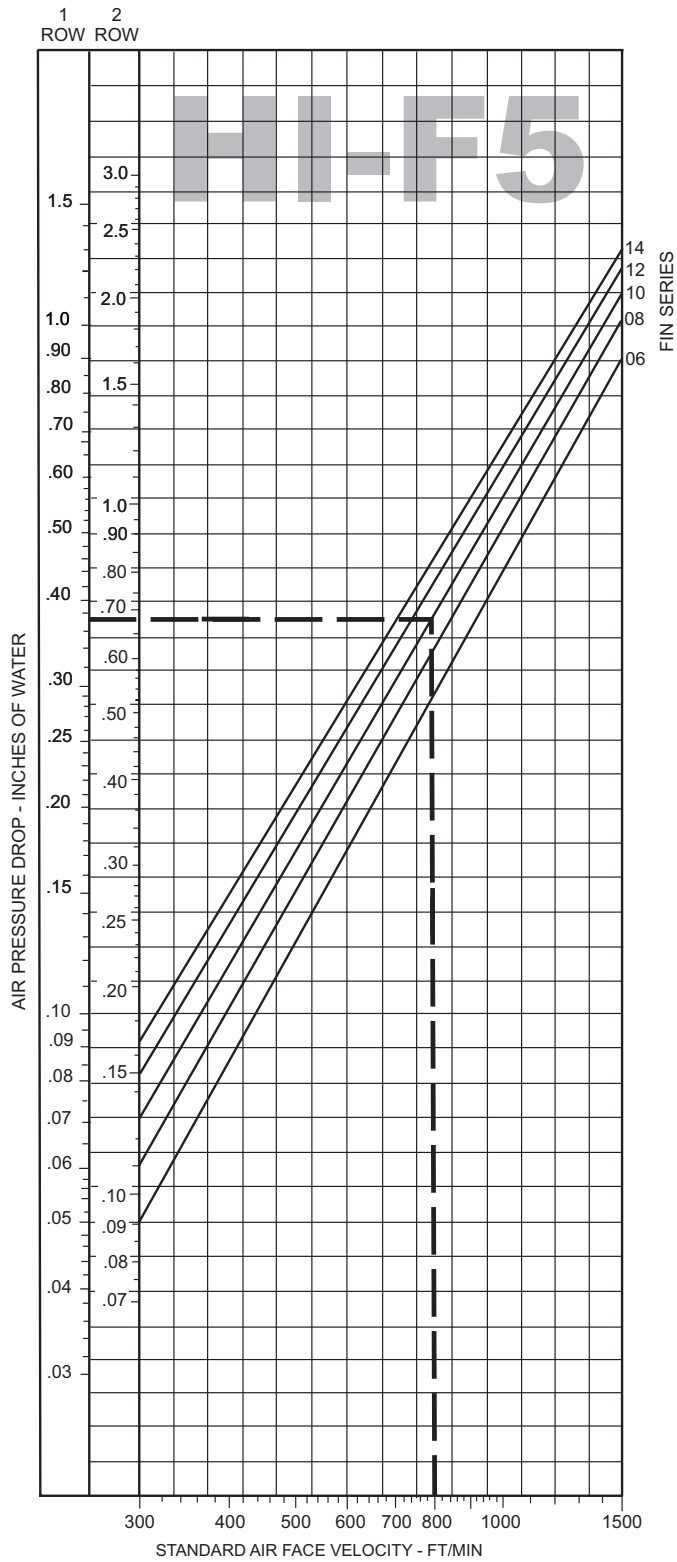

Note: Air pressure drop for odd fin spacings can be found by interpolation.

Figure 22: Coil Air Pressure Drop—E-F5 Fin Type

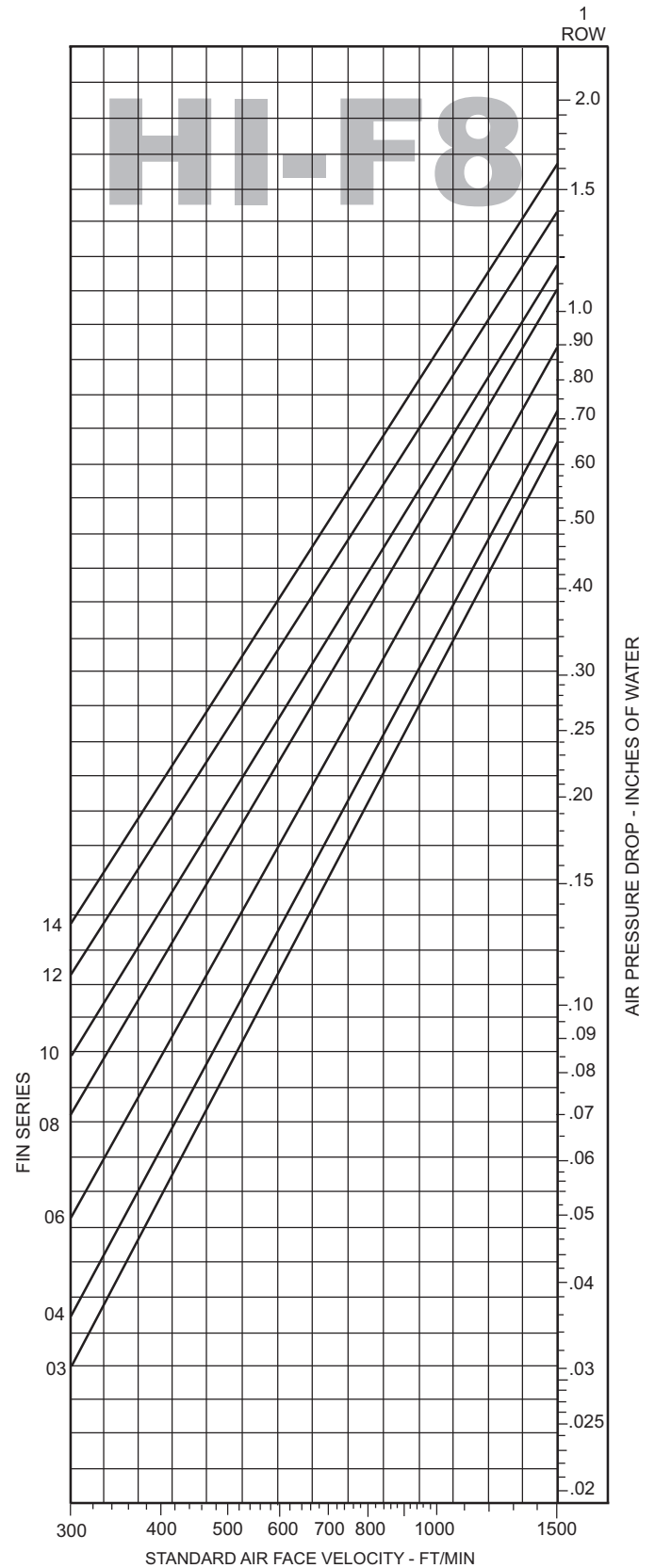

Note: Air pressure drop for odd fin spacings can be found by interpolation.

Figure 23: 1" Steam Coil Air Pressure Drop

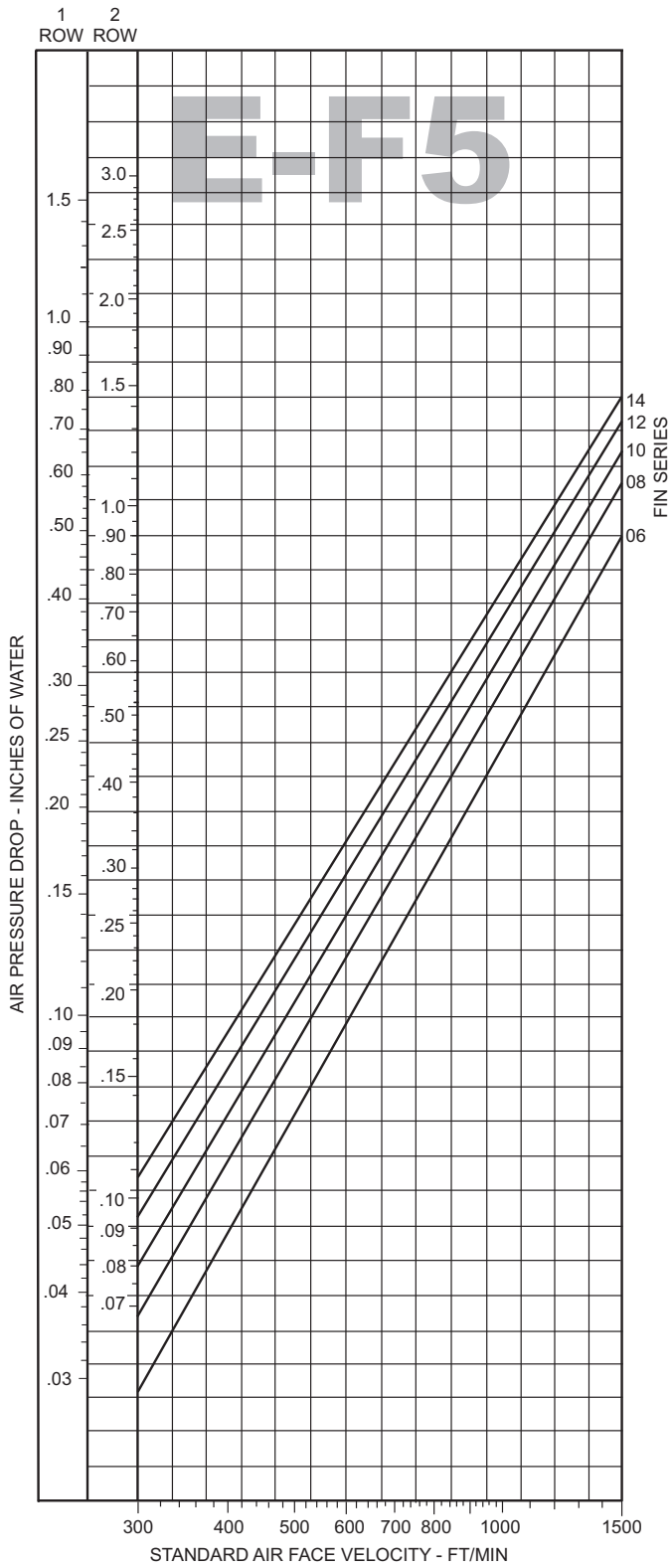

Note: Air pressure drop for odd fin spacings can be found by interpolation

Component and Section Weights

Table 10: Unit Coil Weights

Unit Size	003	004	006	008	010	012	014	017	021	025	030	035	045	055	065	080	085	090
Rows	lbs (kg)	lbs (kg)	lbs (kg)	lbs (kg)	lbs (kg)	lbs (kg)	lbs (kg)	lbs (kg)	lbs (kg)	lbs (kg)	lbs (kg)	lbs (kg)	lbs (kg)	lbs (kg)	lbs (kg)	lbs (kg)	lbs (kg)	lbs (kg)
1	18 (8)	23 (10)	29 (13)	36 (16)	43 (20)	53 (24)	60 (27)	67 (30)	78 (35)	108 (49)	123 (56)	143 (65)	184 (83)	240 (109)	267 (121)	434 (195)	449 (202)	466 (210)
2	26 (12)	33 (15)	43 (20)	54 (24)	66 (30)	83 (38)	92 (42)	107 (49)	125 (57)	166 (75)	189 (86)	222 (101)	302 (137)	396 (180)	446 (202)	663 (298)	678 (305)	711 (320)
3	37 (17)	47 (21)	63 (29)	81 (37)	99 (45)	122 (55)	139 (63)	161 (73)	207 (94)	247 (112)	291 (132)	339 (154)	481 (218)	645 (293)	731 (332)	1239* (558)	1297* (584)	1324* (596)
4	46 (21)	58 (26)	78 (36)	101 (46)	123 (56)	151 (69)	172 (78)	200 (91)	257 (117)	306 (139)	361 () (164)	420 (191)	597 (271)	801 (363)	907 (412)	1711** (770)	1802** (811)	1892** (851)
5	55 (25)	70 (32)	94 (43)	120 (55)	147 (67)	181 (82)	206 (93)	239 (108)	307 (139)	366 (166)	432 (196)	502 (228)	714 (324)	957 (434)	1084 (492)	1959** (882)	2070** (932)	2180** (981)
6	64 (29)	81 (37)	109 (49)	140 (64)	171 (78)	210 (95)	239 (108)	278 (126)	357 (162)	425 (193)	502 (228)	584 (265)	830 (376)	1112 (504)	1260 (572)	2252** (1013)	2383** (1072)	2512** (1130)
8	82 (37)	104 (47)	140 (63)	179 (81)	219 (99)	269 (122)	306 (139)	356 (161)	457 (207)	544 (247)	643 (292)	748 (339)	1062 (482)	1421 (646)	1613 (732)	2828** (1273)	3009** (1354)	3182** (1432)
10	100 (45)	126 (57)	170 (77)	218 (99)	267 (121)	328 (149)	373 (169)	434 (197)	557 (253)	663 (301)	783 (355)	911 (413)	1294 (587)	1735 (787)	1966 (892)	NA	NA	NA
12	118 (53)	149 (68)	201 (91)	258 (117)	315 (143)	386 (175)	440 (200)	512 (232)	657 (298)	782 (355)	924 (419)	1075 (488)	1527 (693)	2046 (928)	2318 (1052)	NA	NA	NA

* 3-row coils (unit sizes 080 to 090) based on staggered medium face area 5EJ with 6 FPI and standard fin, tube and casing materials.

** 4 to 8-row coils (unit sizes 080 to 090) based on staggered medium face area with 12 FPI and standard fin, tube and casing materials

Notes:

• 1 and 2-row (unit sizes 003 to 055) based on large face area 5WQ and 5WH coils with 8 FPI and standard fin, tube and casing materials.

• 3-row and greater (unit sizes 003 to 055) based on large face area 5W* or 5E* coils with 8 FPI and standard fin, tube and casing materials.

• Staggered coils are not available in 10-row and 12-row coils.

Table 11: Weights for Single Speed and Dual Speed Motors

Motor RPM	Motor HP	1/4	1/3	1/3	3/8	1	1-1/2	2	3	5	7-1/2	10	15	20	25	30	40	50	60	75
900 RPM	NEMA frame	—	—	—	—	182T	184T	213T	215T	254T	256T	284T	286T	324T	326T	364T	365T	404T	405T	444T
	Motor weight lbs (kg)	—	—	—	—	56 (25)	64 (29)	94 (43)	111 (50)	150 (68)	207 (94)	300 (136)	300 (136)	385 (175)	415 (189)	580 (349)	580 (264)	750 (461)	800 (364)	1100 (500)
1200 RPM	NEMA frame	—	—	—	—	145T	182T	184T	213T	215T	256T	256T	284T	286T	324T	326T	365T	365T	404T	405T
	Motor weight lbs (kg)	—	—	—	—	44 (20)	66 (30)	85 (39)	114 (52)	145 (66)	224 (102)	248 (113)	330 (150)	377 (153)	450 (205)	487 (221)	703 (320)	720 (327)	1153 (524)	1200 (545)
1800 RPM	NEMA frame	48	48	56	56	143T	145T	145T	182T	184T	213T	215T	254T	256T	284T	286T	324T	326T	364T	365T
	Motor weight lbs (kg)	19 (9)	24 (11)	35 (16)	35 (16)	44 (20)	54 (24)	54 (24)	84 (38)	100 (45)	139 (63)	165 (75)	242 (110)	273 (124)	351 (159)	432 (196)	531 (241)	592 (269)	714 (324)	895 (406)
3600 RPM	NEMA frame	—	—	—	—	56T	143T	145T	145T	182T	184T	213T	215T	254T	256T	284TS	286TS	324TS	326TS	405TS
	Motor weight lbs (kg)	—	—	—	—	32 (15)	40 (18)	40 (18)	50 (23)	76 (35)	91 (41)	110 (50)	147 (67)	182 (83)	223 (101)	359 (163)	369 (168)	447 (203)	558 (254)	713 (324)
1800/900 RPM	NEMA frame	—	—	—	—	143	145	145	182	184	213	215	256	256	286	286	324	326	—	—
	Motor weight lbs (kg)	—	—	—	—	25 (11)	28 (13)	31 (14)	63 (29)	72 (33)	104 (47)	130 (59)	244 (111)	232 (105)	250 (114)	275 (125)	350 (159)	390 (177)	—	—
1800/1200 RPM	NEMA frame	—	—	—	—	145	182	182	184	215	256	256	284	286	286	—	—	—	—	—
	Motor weight lbs (kg)	—	—	—	—	30 (14)	56 (25)	65 (30)	73 (33)	113 (51)	211 (96)	237 (108)	318 (145)	348 (158)	349 (159)	295 (134)	—	—	—	—

*Data included reflects the largest NEMA frame and/or the heaviest motor weight per motor hp.

Table 12: Base Rail Weights

6" Base Rail Weights	Standard Unit Nominal Size																	
	003	004	006	008	010	012	014	017	021	025	030	035	045	055	065	080	085	090
	lbs (kg)	lbs (kg)	lbs (kg)	lbs (kg)	lbs (kg)	lbs (kg)	lbs (kg)	lbs (kg)	lbs (kg)	lbs (kg)	lbs (kg)	lbs (kg)	lbs (kg)	lbs (kg)	lbs (kg)	lbs (kg)	lbs (kg)	lbs (kg)
End Cross Members (Pair)	29 (13)	30 (14)	37 (17)	41 (19)	45 (20)	46 (21)	51 (23)	55 (25)	56 (25)	57 (26)	63 (29)	65 (29)			75 (34)	75 (34)	75 (34)	75 (34)
Add'l. Cross Member Supports	10 (5)	10 (5)	14 (6)	15 (7)	17 (8)	17 (8)	19 (9)	21 (10)	21 (10)	22 (10)	26 (12)	27 (12)			35 (16)	35 (16)	35 (16)	35 (16)

10" Base Rail Weights	Standard Unit Nominal Size																	
	003	004	006	008	010	012	014	017	021	025	030	035	045	055	065	080	085	090
	lbs (kg)	lbs (kg)	lbs (kg)	lbs (kg)	lbs (kg)	lbs (kg)	lbs (kg)	lbs (kg)	lbs (kg)	lbs (kg)	lbs (kg)	lbs (kg)	lbs (kg)	lbs (kg)	lbs (kg)	lbs (kg)	lbs (kg)	lbs (kg)
End Cross Members (Pair)	39 ()	40 (18)	50 (23)	55 (25)	60 (27)	62 (28)	69 (31)	74 (33)	75 (34)	78 (35)	86 (39)	89 (40)			107 (49)	107 (49)	107 (49)	107 (49)
Add'l. Cross Member Supports	14 (6)	15 (7)	19 (9)	21 (10)	24 (11)	24 (11)	27 (12)	30 (14)	30 (14)	32 (15)	36 (16)	38 (17)			50 (23)	50 (23)	50 (23)	50 (23)

Notes:

- Weight factor for 6" high rail = 0.52 lb/in (0.00929 kg/mm)
- Weight factor for 10" high rail = 0.74 lb/in (0.0132 kg/mm)

The base rail weight is determined by adding together the weight of the rail supports that run the length and width of the unit. The lengthwise support depends on the overall unit length. The cross member weight is dependent on the number of cross channels needed to support the unit. Each shipping section has a cross member located on each end. When a unit ships in one piece, the rail will have 2 end channel supports. When the unit ships in numerous shipping sections, each shipping section will have two end pieces. Fan, coil, and attenuator sections each must have additional cross member support on the entering and leaving air side of the section. If the coil section is adjacent to a fan, only one cross member is provided between them. A heating only coil section must have an additional cross member support on the entering air side. Any shipping section over 8' long requires an additional cross member.

Base rails are required on sizes 025 and above.

Example:

Determine the weight of a 6" high base rail for a size 8 unit that is 108" long, consisting of a fan, access, coil, and angular filter in a single shipping section.

Weight factor for unit length for a 6" curb is 0.52 lb/in

$$108" \times 0.52 \text{ lb/in} = 56 \text{ lb} \dots\dots\dots 56 \text{ lb}$$

Weight of end cross members for each shipping section is 41 lb each pair.

$$1 \times 41 \text{ lb} = 41 \text{ lb} \dots\dots\dots 41 \text{ lb}$$

Weight of additional cross members to support fan and coil sections. In this example the fan and coil are separated by an access section; therefore four extra cross member pieces are required for the fan and coil.

$$4 \times 15 = 60 \text{ lb} \dots\dots\dots 60 \text{ lb}$$

$$\text{Total base rail weight} \dots\dots\dots 157 \text{ lb}$$

Fan Data

Table 13: Physical Data—Forward Curved and Airfoil Housed Fans, Unit Sizes 003 to 055

Forward Curved—English Units (SI units)										
Diameter Class I in. (mm)	9×4 (229×102)	9×7 (229×178)	9×9 (229×229)	10.62 (270)	12.62 (321)	15 (381)	18 (457)	20 (508)	22.25 (565)	24.5 (622)
Maximum RPM	N/A	2189	2223	1934	1614	1328	1155	1050	944	858
Shaft and bearing diameter in. (mm)	N/A	1 (25)	1 (25)	1 (25)	1 (25)	1.188 (30)	1.188 (30)	1.938 (49)	2.1875 (56)	2.1875 (56)
Outlet area sq. ft. (sq. m.)	N/A	0.65 (0.06)	0.84 (0.078)	1.04 (0.097)	1.46 (0.136)	2.05 (0.19)	2.87 (0.267)	5.18 (0.481)	6.27 (0.58)	7.63 (0.71)
Diameter Class II in. (mm)	9×4 (229×102)	9×7 (229×178)	9×9 (229×229)	10.62 (270)	12.62 (321)	15 (381)	18 (457)	20 (508)	22.25 (565)	24.5 (622)
Maximum RPM (SI)	2244 (2244)	2854 (2854)	2896 (2896)	2518 (2518)	2091 (2091)	1725 (1725)	1450 (1450)	1200 (1432)	1030 (944)	910 (858)
Shaft and bearing diameter in. (mm)	1 (25)	1 (25)	1 (25)	1 (25)	1.188 (30)	1.188 (30)	1.938 (49)	2.188 (56)	2.4375 (62)	2.4375 (62)
Outlet area sq. ft. (sq. m.)	0.48 (0.045)	0.65 (0.06)	0.84 (0.078)	1.04 (0.097)	1.46 (0.136)	2.05 (0.19)	2.87 (0.267)	5.18 (0.481)	6.27 (0.58)	7.63 (0.71)

Airfoil—English Units (SI Units)						
Diameter Class I in. (mm)	13.22 (336)	14.56 (370)	16.19 (411)	19.69 (500)	21.56 (548)	24 (610)
Maximum RPM	3000	3000	2300	2000	1700	1500
Shaft and bearing diameter in. (mm)	1.188 (30)	1.438 (37)	1.438 (37)	1.938 (49)	1.938 (49)	2.1875 (56)
Outlet area sq. ft. (sq. m.)	2.11 (0.196)	2.85 (0.265)	3.52 (0.327)	4.68 (0.435)	5.82 (0.541)	7.01 (0.65)
Diameter Class II in. (mm)	13.22 (336)	14.56 (370)	16.19 (411)	19.69 (500)	21.56 (548)	24 (610)
Maximum RPM	4335	3918	3457	2858	2547	2255
Shaft and bearing diameter in. (mm)	1.438 (37)	1.688 (43)	1.688 (43)	2.188 (56)	2.438 (62)	2.4375 (62)
Outlet area sq. ft. (sq. m.)	2.11 (0.196)	2.85 (0.265)	3.52 (0.327)	4.68 (0.435)	5.82 (0.541)	7.01 (0.65)

Table 14: Physical Data—Forward Curved and Airfoil Fans, Unit Sizes 045 to 090

Forward Curved—English Units (SI Units)								
Diameter Class I in. (mm)	20 (508)	22.38 (568)	25 (635)	27.62 (702)	30.25 (768)	33 (838)	36 (914)	—
Maximum rpm	1010	930	790	690	650	600	560	—
Shaft and bearing diameter in. (mm)	1.438 (37)	1.438 (37)	1.688 (43)	1.688 (43)	1.688 (43)	2.188 (56)	2.188 (56)	—
Outlet area sq. ft. (sq. m.)	4.2 (0.39)	5.1 (0.474)	6.71 (0.623)	8.07 (0.75)	9.3 (0.864)	12.05 (1.119)	12.8 (1.189)	—
Diameter Class II in. (mm)	20 (508)	22.38 (568)	25 (635)	27.62 (702)	30.25 (768)	33 (838)	36 (914)	—
Maximum rpm	1281	1178	1011	910	835	763	715	—
Shaft and bearing diameter in. (mm)	1.688 (43)	2.188 (56)	2.438 (62)	2.438 (62)	2.688 (68)	2.688 (68)	2.688 (68)	—
Outlet area sq. ft. (sq. m.)	4.2 (0.39)	5.1 (0.474)	6.71 (0.623)	8.07 (0.75)	9.3 (0.864)	12.05 (1.119)	12.8 (1.189)	—

Airfoil—English Units (SI Units)								
Diameter Class I in. (mm)	20 (508)	22.25 (565)	24.5 (622)	27 (686)	30 (762)	33 (838)	36.5 (927)	40.25 (1022)
Maximum rpm	2077	1875	1691	1479	1328	1209	1073	972
Shaft and bearing diameter in. (mm)	1.688 (43)	1.938 (49)	2.188 (56)	2.188 (56)	2.438 (62)	2.438 (62)	2.438 (62)	2.938 (75)
Outlet area sq. ft. (sq. m.)	4.14 (0.385)	5.12 (0.476)	6.21 (0.577)	7.54 (0.7)	9.31 (0.865)	11.27 (1.047)	13.79 (1.281)	16.77 (1.558)
Diameter Class II in. (mm)	20 (508)	22.25 (565)	24.5 (622)	27 (686)	30 (762)	33 (838)	36.5 (927)	40.25 (1022)
Maximum rpm	2703	2413	2199	1928	1730	1579	1401	1264
Shaft and bearing diameter in. (mm)	2.188 (56)	2.188 (56)	2.438 (62)	2.438 (62)	2.688 (68)	2.938 (75)	2.938 (75)	3.438 (87)
Outlet area sq. ft. (sq. m.)	4.14 (0.385)	5.12 (0.476)	6.21 (0.577)	7.54 (0.7)	9.31 (0.865)	11.27 (1.047)	13.79 (1.281)	16.77 (1.558)

Table 15: Physical Data—Direct Drive Plenum Fans

Plenum—English Units (SI Units)														
Diameter Class II in. (mm)	11 (279)	12 (305)	15 (381)	16 (406)	18 (457)	20 (508)	22 (559)	24 (610)	27 (686)	30 (762)	33 (838)	36 (914)	40 (1016)	44 (1118)
Maximum RPM	4000	4000	3909	3650	3650	2674	2403	2183	1981	1783	1620	1465	1329	1202

Note: Includes fan array

Table 16: Physical Data—Twin Fans

Fan Array—English Units (SI Units)						
Fan diameter in. (mm)	12.0 (305)	13.5 (343)	15.0 (381)	16.5 (419)	18.25 (464)	20.0 (508)
Maximum rpm, Class I	4000	4000	3670	3270	2900	2685
Maximum rpm, Class II	N/A	N/A	N/A	3960	3660	N/A

Note: Outlet area is N/A for all fan array sizes due to plenum fans. Shaft and bearing diameter is N/A for all sizes due to direct drive.

Table 17: Physical Data—Belt-Drive Plenum Fans

Plenum—English Units (SI Units)																
Fan Size	13	15	16	18	20	22	24	27	30	33	36	40	44	49	54	60
Diameter Class II in. (mm)	13.5 (343)	15.0 (381)	16.5 (419)	18.25 (464)	20.0 (508)	22.25 (565)	24.5 (622)	27.0 (686)	30.0 (762)	33.0 (838)	36.5 (927)	40.25 (1022)	44 (491)	49 (464)	54 (508)	60 (565)
Maximum RPM	3786	3384	3100	2959	2703	2413	2199	1928	1730	1579	1401	1264	1150	1043	938	847
Shaft and bearing diameter in. (mm)	1.188 (30)	1.188 (30)	1.438 (37)	1.688 (42)	1.688 (42)	1.688 (42)	1.688 (42)	1.688 (42)	1.938 (49)	1.938 (49)	1.938 (49)	2.188 (56)	2.188 (56)	2.438 (62)	2.688 (68)	2.938 (75)
Outlet area sq. ft. (sq. m.).	N/A	N/A	N/A	N/A	N/A	N/A	N/A	N/A	N/A	N/A	N/A	N/A	N/A	N/A	N/A	N/A

Coil Data

Table 18: Dimensional Data (English Units of Measure)—Unit Coil

Standard chilled water, DX, or 3-row and 4-row heating coils (English Units—inches and square feet)							Cleanable coils or 1-row and 2-row heating coils (English Units—inches and square feet)					
Unit Size		Ext/Stagg Large	Large	Ext/Stagg Medium	Medium	Small		Ext/Stagg Large	Large	Ext/Stagg Medium	Medium	Small
003	FH×FL	18×31	18×25	12×31	12×25	—	FH×FL	18×28	18×22	12×28	12×22	—
	Face Area	3.9	3.1	2.6	2.1	—	Face Area	3.5	2.8	2.3	1.8	—
004	FH×FL	21×33	21×27	15×33	15×27	12×27	FH×FL	21×30	21×24	15×30	15×24	12×24
	Face Area	4.8	3.9	3.4	2.8	2.3	Face Area	4.4	3.5	3.1	2.5	2
006	FH×FL	21×45	21×39	15×45	15×39	12×39	FH×FL	21×42	21×36	15×42	15×36	12×36
	Face Area	6.6	5.7	4.7	4.1	3.3	Face Area	6.1	5.3	4.4	3.8	3
008	FH×FL	24×51	24×45	18×51	18×45	15×45	FH×FL	24×48	24×42	18×48	18×42	15×42
	Face Area	8.5	7.5	6.4	5.6	4.7	Face Area	8	7	6	5.3	4.4
010	FH×FL	27×57	27×51	21×57	21×51	18×51	FH×FL	27×54	27×48	21×54	21×48	18×48
	Face Area	10.7	9.6	8.3	7.4	6.4	Face Area	10.1	9	7.9	7	6
012	FH×FL	33×59	33×53	24×59	24×53	21×53	FH×FL	33×56	33×50	24×56	24×50	21×50
	Face Area	13.5	12.1	9.8	8.8	7.7	Face Area	12.8	11.5	9.3	8.3	7.3
014	FH×FL	33×67	33×61	24×67	24×61	21×61	FH×FL	33×64	33×58	24×64	24×58	21×58
	Face Area	15.4	14	11.2	10.2	8.9	Face Area	14.7	13.3	10.7	9.7	8.5
017	FH×FL	36×73	36×67	27×73	27×67	24×67	FH×FL	36×70	36×64	27×70	27×64	24×64
	Face Area	18.3	16.8	13.7	12.6	11.2	Face Area	17.5	16	13.1	12	10.7
021	FH×FL	42×75	42×69	33×75	33×69	30×69	FH×FL	42×72	42×66	33×72	33×66	30×66
	Face Area	21.9	20.1	17.2	15.8	14.4	Face Area	21	19.3	16.5	15.1	13.8
025	FH×FL	48×79	48×73	—	36×73	33×73	FH×FL	—	—	42×70	36×70	33×70
	Face Area	26.3	24.3	—	18.2	16.7	Face Area	—	—	20.4	17.5	16
	FH×FL	(2) 27×73	(2) 24×73	(2) 21×73	—	—	FH×FL	(2) 27×70	(2) 24×70	—	—	—
030	Face Area	27.4	24.3	21.3	—	—	Face Area	26.2	23.3	—	—	—
	FH×FL	48×91	48×85	—	36×85	33×85	FH×FL	—	—	42×82	36×82	33×82
	Face Area	30.3	28.3	—	21.2	19.5	Face Area	—	—	23.9	20.5	18.8
	FH×FL	(2) 27×85	(2) 24×85	(2) 21×85	—	—	FH×FL	(2) 27×82	(2) 24×82	—	—	—
035	Face Area	31.9	28.3	24.8	—	—	Face Area	30.8	27.3	—	—	—
	FH×FL	54×95	54×89	—	42×89	39×89	FH×FL	—	—	—	42×86	39×86
	Face Area	35.6	33.4	—	24.1	22.3	Face Area	—	—	—	23.3	21.5
	FH×FL	(2) 30×89	(2) 27×89	(2) 24×89	—	—	FH×FL	(2) 30×86	(2) 27×86	(2) 24×86	—	—
045	Face Area	37.1	33.4	29.7	—	—	Face Area	35.8	32.3	28.7	—	—
	FH×FL	—	—	—	48×93	—	FH×FL	—	—	—	—	—
	Face Area	—	—	—	31	—	Face Area	—	—	—	—	—
	FH×FL	(2) 39×93	(2) 33×93	(2) 27×93	(2) 24×93	—	FH×FL	(2) 39×90	(2) 33×90	(2) 27×90	(2) 24×90	—
055	Face Area	50.4	42.6	34.9	31.0	—	Face Area	48.8	41.3	33.8	30.0	—
	FH×FL	(2) 45×93	—	—	—	—	FH×FL	—	—	—	—	—
	Face Area	58.1	—	—	—	—	Face Area	—	—	—	—	—
	FH×FL	—	(2) 39×93	(2) 36×93	(2) 30×93	—	FH×FL	—	(2) 39×90	(2) 36×90	(2) 30×90	—
065	Face Area	—	50.4	46.5	38.8	—	Face Area	—	48.8	45.0	37.5	—
	FH×FL	—	—	—	—	54×123	FH×FL	—	—	—	—	—
	Face Area	—	—	—	—	46.1	Face Area	—	—	—	—	—
	FH×FL	(2) 45×123	(2) 39×123	(2) 36×123	(2) 30×123	(2) 27×123	FH×FL	—	(2) 39×120	(2) 36×120	(2) 30×120	(2) 27×120
080	Face Area	76.9	66.6	61.5	51.2	46.1	Face Area	—	65	60	50	45
	FH×FL	—	—	—	—	54×123	FH×FL	—	—	—	—	—
	Face Area	—	—	—	—	46.1	Face Area	—	—	—	—	—
	FH×FL	(2) 48×123	(2) 42×123	(2) 36×123	(2) 30×123	(2) 27×123	FH×FL	—	(2) 42×120	(2) 36×120	(2) 30×120	(2) 27×120
085	Face Area	82	71.8	61.5	51.2	46.1	Face Area	—	70	60	50	45
	FH×FL	—	—	—	—	—	FH×FL	—	—	—	—	—
	Face Area	—	—	—	—	—	Face Area	—	—	—	—	—
	FH×FL	(2) 51×123	(2) 45×123	(2) 39×123	(2) 33×123	(2) 30×123	FH×FL	—	—	(2) 39×120	(2) 33×120	(2) 30×120
090	Face Area	87.1	76.9	66.6	56.4	51.2	Face Area	—	—	65	55	50
	FH×FL	—	—	—	—	—	FH×FL	—	—	—	—	—
	Face Area	—	—	—	—	—	Face Area	—	—	—	—	—
	FH×FL	(2) 54×123	(2) 48×123	(2) 42×123	(2) 36×123	(2) 33×123	FH×FL	—	—	(2) 42×120	(2) 36×120	(2) 33×120
090	Face Area	92.2	82	71.8	61.5	56.4	Face Area	—	—	70	60	55

Coil section depth limitation by number of rows in coil for single banks of coils (excludes staggered coils)

Section depth	Maximum number of rows
12"	2-row water or steam
14"	4-row water (except 5WM and 5WD)
16"	4-row 5WM & 5WD water

Cooling only section (no moisture eliminator)

Section depth	Maximum number of rows
18"	4-row DX or water (except 5WM and 5WD)
24"	8-row DX or water
30"	10-row DX or 12 water

Combination cooling and 1-row or 2-row reheat (no moisture eliminator)

Section depth	Maximum number of rows
24"	6-row water or DX
30"	10-row water or DX
36"	12-row water

Notes: Spacing between coil casings is a minimum of 4". If more access between coils is required, increase section depth. Cooling coil sections are available in section depths of 457 mm, 610 mm, 762 mm, 914 mm, 1067 mm, 1219 mm, 1372 mm. If a moisture eliminator is required, use the next larger section size.

Table 19: Dimensional Data (SI Units of Measure)—Unit Coil

Standard chilled water, DX, or 3-row and 4-row heating coils (SI units—millimeters and square meters)							Cleanable coils or 1-row and 2-row heating coils (SI units—millimeters and square meters)					
Unit Size	Ext/Stagg Large	Large	Ext/Stagg Medium	Medium	Small		Ext/Stagg Large	Large	Ext/Stagg Medium	Medium	Small	
003	FH×FL	0.36	0.29	0.24	0.20	—	FH×FL	457×711	457×559	305×711	305×559	—
	Face Area	457×787	457×635	305×787	305×635	—	Face Area	0.33	0.26	0.21	0.17	—
004	FH×FL	0.45	0.36	0.32	0.26	0.21	FH×FL	533×762	533×610	381×762	381×610	305×610
	Face Area	533×838	533×686	381×838	381×686	305×686	Face Area	0.41	0.33	0.29	0.23	0.19
006	FH×FL	0.61	0.53	0.44	0.38	0.31	FH×FL	533×1067	533×914	381×1067	381×914	305×914
	Face Area	533×1143	533×991	381×1143	381×991	305×991	Face Area	0.57	0.49	0.41	0.35	0.28
008	FH×FL	0.79	0.70	0.59	0.52	0.44	FH×FL	610×1219	610×1067	457×1219	457×1067	381×1067
	Face Area	610×1295	610×1143	457×1295	457×1143	381×1143	Face Area	0.74	0.65	0.56	0.49	0.41
010	FH×FL	0.99	0.89	0.77	0.69	0.59	FH×FL	686×1372	686×1219	533×1372	533×1219	457×1219
	Face Area	686×1448	686×1295	533×1448	533×1295	457×1295	Face Area	0.94	0.84	0.73	0.65	0.56
012	FH×FL	1.25	1.12	0.91	0.82	0.72	FH×FL	838×1422	838×1270	610×1422	610×1270	533×1270
	Face Area	838×1499	838×1346	610×1499	610×1346	533×1346	Face Area	1.19	1.07	0.86	0.77	0.68
014	FH×FL	1.43	1.30	1.04	0.95	0.83	FH×FL	838×1626	838×1473	610×1626	610×1473	533×1473
	Face Area	838×1702	838×1549	610×1702	610×1549	533×1549	Face Area	1.37	1.24	0.99	0.90	0.79
017	FH×FL	1.70	1.56	1.27	1.17	1.04	FH×FL	914×1778	914×1626	686×1778	686×1626	610×1626
	Face Area	914×1854	914×1702	686×1854	686×1702	610×1702	Face Area	1.63	1.49	1.22	1.11	0.99
021	FH×FL	2.03	1.87	1.60	1.47	1.34	FH×FL	1067×1829	1067×1676	838×1829	838×1676	762×1676
	Face Area	1067×1905	1067×1753	838×1905	838×1753	762×1753	Face Area	1.95	1.79	1.53	1.40	1.28
025	FH×FL	2.44	2.26	—	1.89	1.55	FH×FL	—	—	1067×1778	914×1778	838×1778
	Face Area	1219×2007	1219×1854	—	914×1854	838×1854	Face Area	—	—	1.89	1.63	1.49
	FH×FL	2.55	2.60	1.98	—	—	FH×FL	(2) 686×1778	(2) 610×1778	—	—	—
	Face Area	(2) 686×1854	(2) 610×1854	(2) 533×1854	—	—	Face Area	2.43	2.16	—	—	—
030	FH×FL	2.81	2.63	—	1.97	1.81	FH×FL	—	—	1067×2083	914×2083	838×2083
	Face Area	1219×2312	1219×2159	—	914×2159	838×2159	Face Area	—	—	2.22	1.90	1.75
	FH×FL	3.45	2.63	2.30	—	—	FH×FL	(2) 686×2083	(2) 610×2083	—	—	—
	Face Area	(2) 686×2159	(2) 610×2159	(2) 533×2159	—	—	Face Area	2.86	2.54	—	—	—
035	FH×FL	3.31	3.10	—	2.24	2.07	FH×FL	—	—	—	1067×2184	991×2184
	Face Area	1372×2413	1372×2261	—	991×2261	914×2261	Face Area	—	—	—	2.33	2.16
	FH×FL	3.46	3.10	2.76	—	—	FH×FL	(2) 762×2184	(2) 686×2184	(2) 610×2184	—	—
	Face Area	(2) 762×2261	(2) 686×2261	(2) 607×2261	—	—	Face Area	3.33	3.00	2.66	—	—
045	FH×FL	—	—	—	1219×2362	—	FH×FL	—	—	—	—	—
	Face Area	—	—	—	2.88	—	Face Area	—	—	—	—	—
	FH×FL	(2) 991×2362	(2) 838×2362	(2) 686×2362	(2) 610×2362	—	FH×FL	(2) 991×2286	(2) 838×2286	(2) 686×2286	(2) 610×2286	—
	Face Area	4.67	3.96	3.24	2.88	—	Face Area	4.53	3.83	3.14	2.79	—
055	FH×FL	(2) 1143×2362	—	—	—	—	FH×FL	—	—	—	—	—
	Face Area	5.39	—	—	—	—	Face Area	—	—	—	—	—
	FH×FL	—	(2) 991×2362	(2) 914×2362	(2) 762×2362	—	FH×FL	—	(2) 991×2286	(2) 914×2286	(2) 762×2286	—
065	Face Area	—	4.67	4.32	3.60	—	Face Area	—	4.53	4.18	3.48	—
	FH×FL	—	—	—	—	4.28	FH×FL	—	—	—	—	—
	Face Area	—	—	—	—	1372×3124	Face Area	—	—	—	—	—
	FH×FL	7.14	6.19	5.71	4.76	4.28	FH×FL	—	(2) 991×3048	(2) 915×3048	(2) 762×3048	(2) 686×3048
080	Face Area	(2) 1143×3124	(2) 991×3124	(2) 915×3124	(2) 762×3124	(2) 686×3124	Face Area	—	6.04	5.57	4.65	4.18
	FH×FL	—	—	—	—	4.28	FH×FL	—	—	—	—	—
	Face Area	—	—	—	—	1372×3124	Face Area	—	—	—	—	—
085	FH×FL	7.61	6.67	5.71	4.75	4.28	FH×FL	—	(2) 1067×3048	(2) 915×3048	(2) 762×3048	(2) 686×3048
	Face Area	(2) 1219×3124	(2) 1067×3124	(2) 915×3124	(2) 762×3124	(2) 686×3124	Face Area	—	6.50	5.57	4.64	4.18
	FH×FL	—	—	—	—	—	FH×FL	—	—	—	—	—
	Face Area	—	—	—	—	—	Face Area	—	—	—	—	—
090	FH×FL	8.09	7.14	6.18	5.24	4.75	FH×FL	—	—	(2) 991×3048	(2) 838×3048	(2) 762×3048
	Face Area	(2) 1296×3124	(2) 1143×3124	(2) 991×3124	(2) 838×3124	(2) 762×3124	Face Area	—	—	6.04	5.11	4.64
	FH×FL	—	—	—	—	—	FH×FL	—	—	—	—	—
090	Face Area	—	—	—	—	—	Face Area	—	—	—	—	—
	FH×FL	8.56	7.61	6.67	5.71	5.24	FH×FL	—	—	(2) 1067×3048	(2) 915×3048	(2) 838×3048
	Face Area	(2) 1372×3124	(2) 1219×3124	(2) 1067×3124	(2) 915×3124	(2) 838×3124	Face Area	—	—	6.50	5.57	5.11

Coil section depth limitation by number of rows in coil for single banks of coils (excludes staggered coils)
 Section depth Maximum number of rows
 305 mm. 2-row water or steam
 356 mm. 4-row water (except 5WM and 5WD)
 406 mm. 4-row 5WM & 5WD water

Cooling only section (no moisture eliminator)
 Section depth Maximum number of rows
 457 mm. 4-row DX or water (except 5WM and 5WD)
 610 mm. 8-row DX or water
 762 mm. 10-row DX or 12 water

Combination cooling and 1-row or 2-row reheat (no moisture eliminator)
 Section depth Maximum number of rows
 610 mm. 6-row water or DX
 762 mm. 10-row water or DX
 914 mm. 12-row water

Notes: Spacing between coil casings is a minimum of 101.6 mm. If more access between coils is required, increase section depth. Cooling coil sections are available in section depths of 457 mm, 610 mm, 762 mm, 914 mm, 1067 mm, 1219 mm, 1372 mm. If a moisture eliminator is required, use the next larger section size.

Side Load Filter Data

Table 20: Size and Quantity of Filters Used Per Unit Size

Unit Size	Filter Size (in.)	Number of Filters Used per Filter Section						
		2" Throwaway (TA)	2" Angular	4" Angular	12" Cartridge	4" Cartridge	12" Mini Pleat	Bag
003	12×24		2					
	20×20							
	20×24		2					
	24×12			N/A				
	24×20	1			1	1	1	1
004	12×24	1	2		1	1	1	1
	20×20							
	20×24							
	24×12			N/A				
	24×20							
006	24×24	1	2		1	1	1	1
	12×24							
	20×20							
	20×24							
	24×12			N/A				
008	24×20							
	24×24	2	4		2	2	2	2
	12×24	1	2	2	1	1	1	1
	20×20							
	20×24	1	2	2	2	2	2	2
010	24×12							
	24×20							
	24×24	1	2	2				
	12×24				1			
	20×20							
012	20×24	3	6	6		3	3	3
	24×12							
	24×20							
	24×24	2			2	2	2	2
	12×24	1			1	1	1	1
014	20×20							
	20×24		4	4				
	24×12	2			2	2	2	2
	24×20							
	24×24	2	2	2	2	2	2	2
017	12×24							
	20×20							
	20×24	3	3					
	24×12							
	24×20	6	6					
021	24×24							
	24×20	6	6	6	6	6		
	24×24	3	3	3				
	12×24							
	20×20	4			4	4		4
021	20×24	4	12	12	4	4		4
	24×12							
	24×20						3	
24×24						3		

Table 20 continued: Size and Quantity of Filters Used Per Unit Size

Unit Size	Filter size (in.)	Number of filters used per filter section						
		2" throwaway (TA)	2" angular	4" angular	12" cartridge	4" cartridge	12" mini pleat	Bag
025	12×24				2	2	2	2
	20×20							
	20×24	6	9	9				
	24×12							
	24×20							
030	24×24	2	3	3	6	6	6	6
	12×24							
	20×20							
	20×24							
	24×12	4			4	4	4	4
035	24×20	8			8	8	8	8
	24×24		12	12				
	12×24							
	20×20	15			15	15		15
	20×24		20	20				
045	24×12							
	24×20						12	
	24×24							
	12×24		4	4	3			
	20×20							
055	20×24	12	4	4	3	12	12	12
	24×12							
	24×20	3	12	12	9	3	3	3
	12×24						3	
	20×20	12			15	12		12
065	20×24	4	20	20	5	4	3	4
	24×12						3	
	24×20	3				3		3
	24×24	1	5	5	1	9	1	
	12×24				3		3	
080	20×20		9			9		9
	20×24	3	10	10		3		3
	24×12				5		5	
	24×20	9				9		9
	24×24	3	20	20	15	3	15	3
085	12×24				3		3	
	20×20		3			3		3
	20×24	9	10	10		9		9
	24×12							
	24×20	3	5	3	5	3		
090	24×24	9	20	20	15	9	15	9
	12×24	4		4	4	4	4	4
	20×20							
	20×24	12	12	12				
	24×12							
090	24×20	4	24	24	20	20	20	20
	12×24						3	
	20×20	12			15	12		12
	20×24	3	12	12		3		3
	24×12						5	
090	24×20	12			15	12	5	12
	24×24	3	24	24		3	15	3

Note: Number of filters used per flat panel, 2" angular, and 4" angular filter section is based on pleated (30%).

Top Horizontal Housed Fan Discharge

Figure 24: Dimensional Data—Top Horizontal Housed Fan Discharge

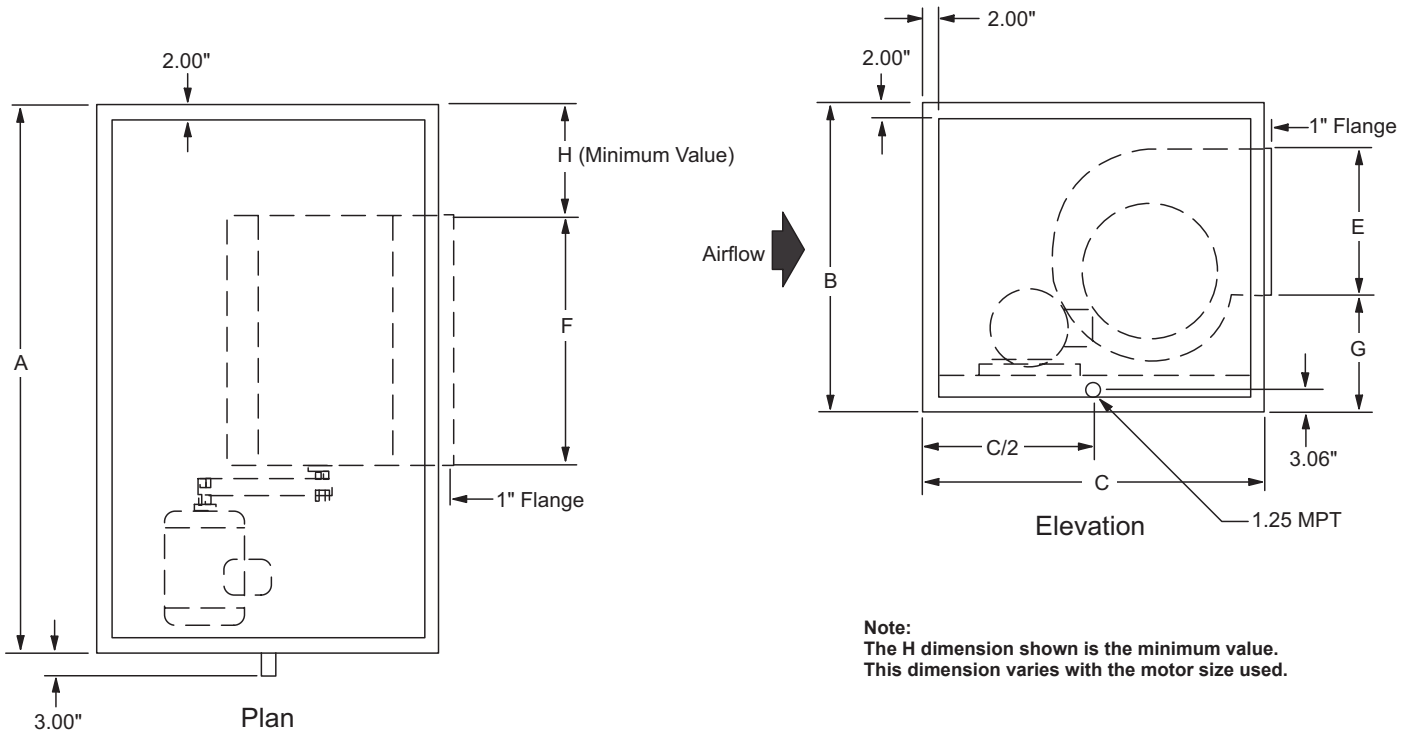

Table 21: Fan Opening Dimensions—Top Horizontal Housed Fan Discharge Models 003 to 090

Forward Curve	Fan Diameter		Airfoil	E in. (mm)	F in. (mm)
	E in. (mm)	F in. (mm)			
Models 003—035					
9×4	11.05 (281)	7.61 (193)	13.22	16.68 (424)	19.94 (506)
9×7	11.05 (281)	9.99 (254)	14.56	20.18 (513)	22.00 (559)
9×9	11.05 (281)	12.61 (320)	16.19	22.37 (568)	24.31 (617)
10.62	12.18 (309)	13.92 (354)	19.69	24.13 (613)	29.70 (754)
12.62	14.24 (362)	16.42 (417)	21.56	27.27 (693)	32.45 (824)
15	16.68 (424)	19.42 (493)	24	29.51 (750)	35.95 (913)
18	19.68 (500)	22.68 (576)			
20	27.27 (693)	28.98 (736)			
22.25	29.51 (750)	32.23 (819)			
24.5	32.51 (826)	35.45 (900)			
Models 040—090					
20	25.55 (649)	25.55 (649)	20	22.05 (560)	29.49 (749)
22.38	28.05 (712)	28.05 (712)	22.25	24.43 (621)	32.18 (817)
25	32.05 (814)	32.05 (814)	24.5	26.74 (679)	35.68 (906)
27.62	35.05 (890)	35.05 (890)	27	29.43 (748)	39.11 (993)
30.25	37.55 (954)	37.55 (954)	30	32.61 (828)	43.24 (1098)
33	43.74 (1111)	40.55 (1030)	33	35.74 (908)	47.99 (1219)
36	43.74 (1111)	43.55 (1106)	36.5	39.49 (1003)	52.55 (1335)
40.25	43.36 (1101)	58.30 (1481)			

Table 22: Fan Dimensions—Top Horizontal Housed Fan Discharge

Unit Size (Fan Diameter)	A**	B**	C	G	H (min)
	in (mm)	in (mm)	in (mm)	in (mm)	in (mm)
003 (9x4, 9x7 FC)*	38.00 (965)	26.00 (660)	32.00 (813)	9.93 (252)	8.18 (208)
004 (9x9 FC)*	40.00 (1016)	30.00 (762)	32.00 (813)	9.93 (252)	8.18 (208)
006 (9x7, 9x9 FC)*	52.00 (1321)	30.00 (762)	32.00 (813)	9.93 (252)	8.18 (208)
006 (10.62 FC)*	52.00 (1321)	30.00 (762)	36.00 (914)	12.74 (324)	9.43 (240)
008 (12.62 FC)	58.00 (1473)	34.00 (864)	40.00 (1016)	14.61 (371)	10.83 (275)
008 (13.22 AF)	58.00 (1473)	34.00 (864)	40.00 (1016)	13.88 (353)	11.25 (286)
010 (15 FC)	64.00 (1626)	36.00 (914)	42.00 (1067)	15.55 (395)	12.50 (318)
010 (13.22 AF)	64.00 (1626)	36.00 (914)	40.00 (1016)	13.88 (353)	11.25 (286)
012 (18 FC)	66.00 (1676)	42.00 (1067)	46.00 (1168)	16.80 (427)	14.62 (371)
012 (16.19 AF)	66.00 (1676)	42.00 (1067)	46.00 (1168)	14.28 (363)	13.33 (339)
014 (18 FC)	74.00 (1880)	42.00 (1067)	46.00 (1168)	16.80 (427)	14.62 (371)
014 (16.19 AF)	74.00 (1880)	42.00 (1118)	46.00 (1168)	14.28 (363)	13.33 (339)
017 (18 FC)	80.00 (2032)	46.00 (1168)	46.00 (1168)	16.80 (427)	14.62 (371)
017 (19.69 AF)	80.00 (2032)	46.00 (1168)	50.00 (1270)	16.09 (409)	15.78 (401)
021 (20 FC)	82.00 (2083)	52.00 (1321)	52.00 (1321)	15.82 (402)	16.00 (406)
021 (21.56 AF)	82.00 (2083)	52.00 (1321)	52.00 (1321)	16.06 (408)	17.09 (434)
025 (24.50 FC)*	86.00 (2184)	60.00 (1524)	60.00 (1524)	18.63 (473)	19.15 (486)
025 (24 AF)	86.00 (2184)	60.00 (1524)	58.00 (1473)	17.55 (446)	18.80 (478)
030 (24.50 FC)	98.00 (2489)	60.00 (1524)	60.00 (1524)	18.63 (473)	19.15 (486)
030 (24 AF)	98.00 (2489)	60.00 (1524)	58.00 (1473)	17.55 (446)	18.80 (478)
035 (24.50 FC)	102.00 (2591)	66.00 (1676)	60.00 (1524)	18.63 (473)	19.15 (486)
035 (24 AF)	102.00 (2591)	66.00 (1676)	58.00 (1473)	17.55 (446)	18.80 (478)
045 (24.50 FC)	106.00 (2692)	78.00 (1981)	60.00 (1524)	18.63 (473)	19.15 (486)
045 (24 AF)	106.00 (2692)	78.00 (1981)	58.00 (1473)	17.55 (446)	18.80 (478)
055 (24.50 FC)	106.00 (2692)	90.00 (2286)	60.00 (1524)	18.63 (473)	19.15 (486)
055 (24 AF)	106.00 (2692)	90.00 (2286)	58.00 (1473)	17.55 (446)	18.80 (478)
065 (40.25 AF)	136.00 (3454)	92.00 (2337)	92.00 (2337)	43.65 (1109)	34.85 (987)
080 (40.25 AF)	136.00 (3454)	98.00 (2489)	92.00 (2337)	43.65 (1109)	34.85 (987)
085 (40.25 AF)	136.00 (3454)	104.00 (2641)	92.00 (2337)	43.65 (1109)	34.85 (987)
090 (40.25 AF)	136.00 (3454)	110.00 (2794)	92.00 (2337)	43.65 (1109)	34.85 (987)

* Not available with vanes.

** These are the dimensions of the unit only. Curb-ready base adds 6" (152 mm) to the unit height. A standard base rail adds 8" (203 mm) to the width, and between 4" to 12" (102 mm to 305 mm) to the unit height. Height dimension does not include 2" roof cap seam.

Bottom Horizontal Housed Fan Discharge

Figure 25: Dimensional Data—Bottom Horizontal Housed Fan Discharge

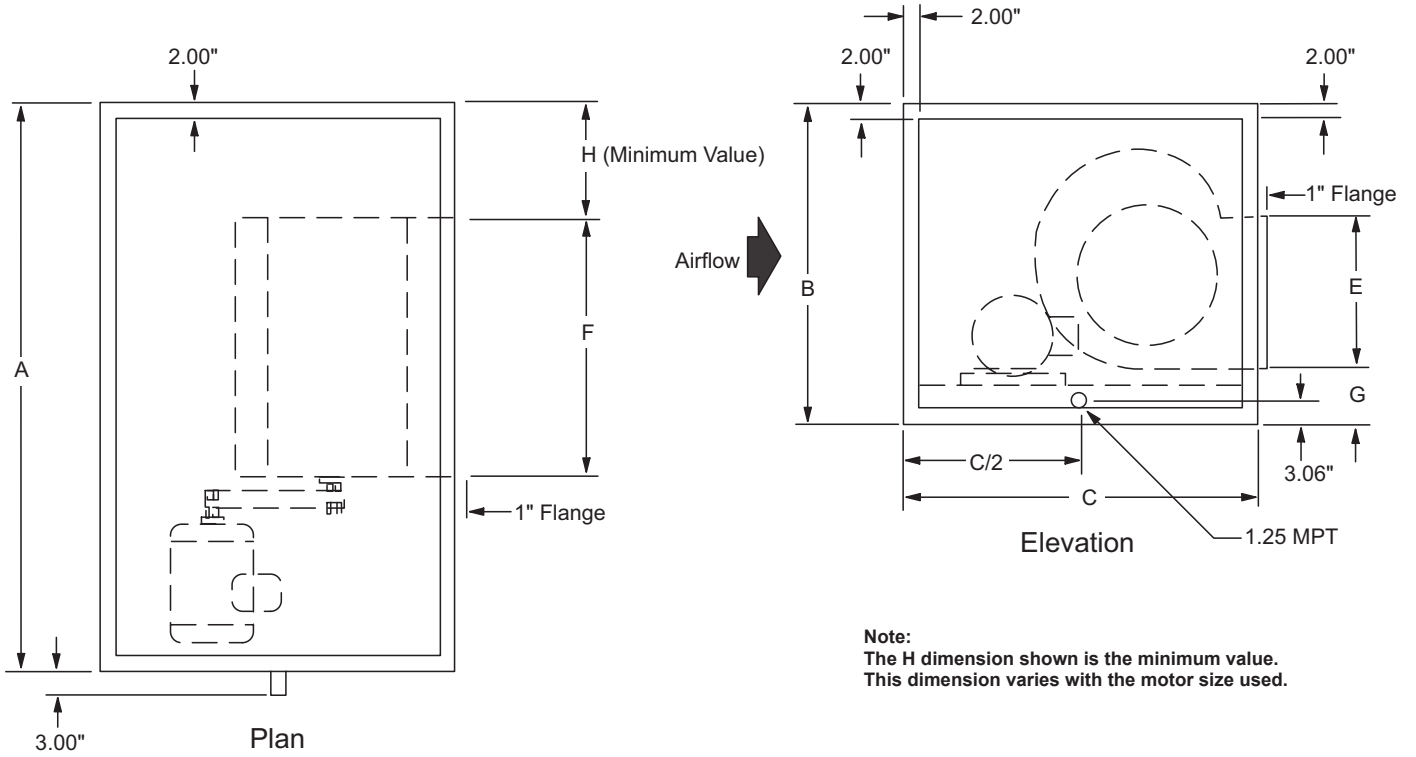

Table 23: Fan Opening Dimensions— Bottom Horizontal Housed Fan Discharge Models 003 to 090

Fan Diameter					
Forward Curve	E in. (mm)	F in. (mm)	Airfoil	E in. (mm)	F in. (mm)
Models 003—035					
9×4	11.05 (281)	7.61 (193)	13.22	16.68 (424)	19.94 (506)
9×7	11.05 (281)	9.99 (254)	14.56	20.18 (513)	22.00 (559)
9×9	11.05 (281)	12.61 (320)	16.19	22.37 (568)	24.31 (617)
10.62	12.18 (309)	13.92 (354)	19.69	24.13 (613)	29.70 (754)
12.62	14.24 (362)	16.42 (417)	21.56	27.27 (693)	32.45 (824)
15	16.68 (424)	19.42 (493)	24	29.51 (750)	35.95 (913)
18	19.68 (500)	22.68 (576)			
20	27.27 (693)	28.98 (736)			
22.25	29.51 (750)	32.23 (819)			
24.5	32.51 (826)	35.45 (900)			
Models 040—090					
20	25.55 (649)	25.55 (649)	20	22.05 (560)	29.49 (749)
22.38	28.05 (712)	28.05 (712)	22.25	24.43 (621)	32.18 (817)
25	32.05 (814)	32.05 (814)	24.5	26.74 (679)	35.68 (906)
27.62	35.05 (890)	35.05 (890)	27	29.43 (748)	39.11 (993)
30.25	37.55 (954)	37.55 (954)	30	32.61 (828)	43.24 (1098)
33	43.74 (1111)	40.55 (1030)	33	35.74 (908)	47.99 (1219)
36	43.74 (1111)	43.55 (1106)	36.5	39.49 (1003)	52.55 (1335)
40.25	43.36 (1101)	58.30 (1481)			

Table 24: Fan Dimensions—Bottom Horizontal Housed Fan Discharge

Unit Size (Fan Diameter)	A**	B**	C	G	H (min)
	in. (mm)	in. (mm)	in. (mm)	in. (mm)	in. (mm)
003 (9x4, 9x7 FC)*	38.00 (965)	26.00 (660)	32.00 (813)	6.43 (163)	8.18 (208)
004 (9x9 FC)*	40.00 (1016)	30.00 (762)	32.00 (813)	6.43 (163)	8.18 (208)
006 (9x7, 9x9 FC)*	52.00 (1321)	30.00 (762)	32.00 (813)	6.43 (163)	8.18 (208)
006 (10.62 FC)*	52.00 (1321)	30.00 (762)	36.00 (914)	8.50 (216)	9.43 (240)
008 (12.62 FC)	58.00 (1473)	34.00 (864)	40.00 (1016)	8.50 (216)	10.83 (275)
008 (13.22 AF)	58.00 (1473)	34.00 (864)	40.00 (1016)	8.50 (216)	11.25 (286)
010 (15 FC)	64.00 (1626)	36.00 (914)	42.00 (1067)	8.50 (216)	12.50 (318)
010 (13.22 AF)	64.00 (1626)	36.00 (914)	40.00 (1016)	8.50 (216)	11.25 (286)
012 (18 FC)	66.00 (1676)	42.00 (1067)	46.00 (1168)	8.50 (216)	14.62 (371)
012 (16.19 AF)	66.00 (1676)	42.00 (1067)	46.00 (1168)	8.50 (216)	13.33 (339)
014 (18 FC)	74.00 (1880)	42.00 (1067)	46.00 (1168)	8.50 (216)	14.62 (371)
014 (16.19 AF)	74.00 (1880)	42.00 (1118)	46.00 (1168)	8.50 (216)	13.33 (339)
017 (18 FC)	80.00 (2032)	46.00 (1168)	46.00 (1168)	8.50 (216)	14.62 (371)
017 (19.69 AF)	80.00 (2032)	46.00 (1168)	50.00 (1270)	8.50 (216)	15.78 (401)
021 (20 FC)	82.00 (2083)	52.00 (1321)	52.00 (1321)	8.50 (216)	16.00 (406)
021 (21.56 AF)	82.00 (2083)	52.00 (1321)	52.00 (1321)	8.50 (216)	17.09 (434)
025 (24.50 FC)*	86.00 (2184)	60.00 (1524)	60.00 (1524)	8.50 (216)	19.15 (486)
025 (24 AF)	86.00 (2184)	60.00 (1524)	58.00 (1473)	8.50 (216)	18.80 (478)
030 (24.50 FC)	98.00 (2489)	60.00 (1524)	60.00 (1524)	8.50 (216)	19.15 (486)
030 (24 AF)	98.00 (2489)	60.00 (1524)	58.00 (1473)	8.50 (216)	18.80 (478)
035 (24.50 FC)	102.00 (2591)	66.00 (1676)	60.00 (1524)	8.50 (216)	19.15 (486)
035 (24 AF)	102.00 (2591)	66.00 (1676)	58.00 (1473)	8.50 (216)	18.80 (478)
045 (24.50 FC)	106.00 (2692)	68.00 (1727)	60.00 (1524)	8.50 (216)	19.15 (486)
045 (24 AF)	106.00 (2692)	68.00 (1727)	58.00 (1473)	8.50 (216)	18.80 (478)
055 (24.50 FC)	106.00 (2692)	78.00 (1981)	60.00 (1524)	8.50 (216)	19.15 (486)
055 (24 AF)	106.00 (2692)	78.00 (1981)	58.00 (1473)	8.50 (216)	18.80 (478)
065 (40.25 AF)	136.00 (3454)	92.00 (2337)	92.00 (2337)	14.09 (358)	34.85 (987)
080 (40.25 AF)	136.00 (3454)	98.00 (2489)	92.00 (2337)	14.09 (358)	34.85 (987)
085 (40.25 AF)	136.00 (3454)	104.00 (2641)	92.00 (2337)	14.09 (358)	34.85 (987)
090 (40.25 AF)	136.00 (3454)	110.00 (2794)	92.00 (2337)	14.09 (358)	34.85 (987)

* Not available with vanes.

** These are the dimensions of the unit only. Curb-ready base adds 6" (152 mm) to the unit height. A standard base rail adds 8" (203 mm) to the width, and between 4" to 12" (102 mm to 305 mm) to the unit height. Height dimension does not include 2" roof cap seam.

Upblast Housed Fan Discharge

Figure 26: Dimensional Data—Upblast Housed Fan Discharge

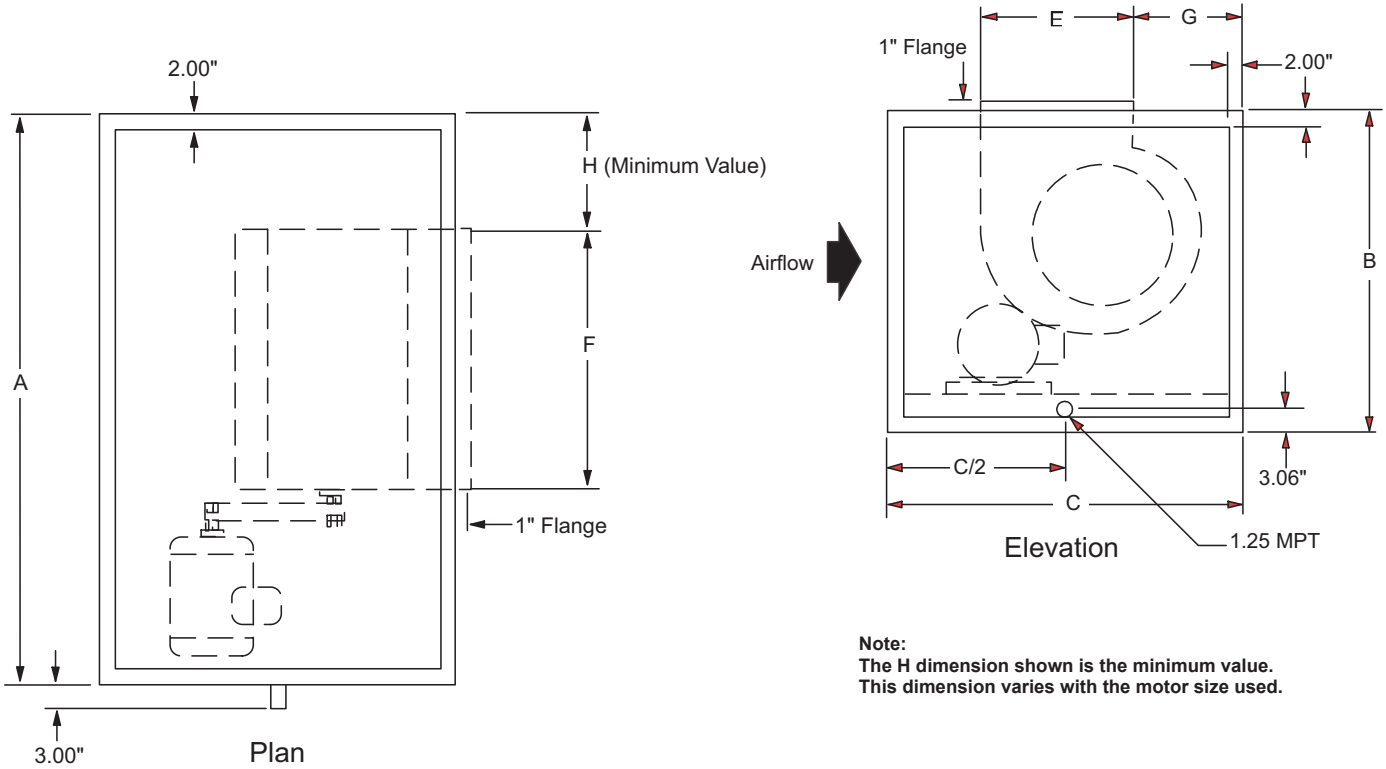

Table 25: Fan Opening Dimensions— Upblast Housed Fan Discharge Models 003 to 090

Fan Diameter					
Forward Curve	E in. (mm)	F in. (mm)	Airfoil	E in. (mm)	F in. (mm)
Models 003—035					
9×4	11.05 (281)	7.61 (193)	13.22	16.68 (424)	19.94 (506)
9×7	11.05 (281)	9.99 (254)	14.56	20.18 (513)	22.00 (559)
9×9	11.05 (281)	12.61 (320)	16.19	22.37 (568)	24.31 (617)
10.62	12.18 (309)	13.92 (354)	19.69	24.13 (613)	29.70 (754)
12.62	14.24 (362)	16.42 (417)	21.56	27.27 (693)	32.45 (824)
15	16.68 (424)	19.42 (493)	24	29.51 (750)	35.95 (913)
18	19.68 (500)	22.68 (576)			
Models 040—090					
20	25.55 (649)	25.55 (649)	20	22.05 (560)	29.49 (749)
22.38	28.05 (712)	28.05 (712)	22.25	24.43 (621)	32.18 (817)
25	32.05 (814)	32.05 (814)	24.5	26.74 (679)	35.68 (906)
27.62	35.05 (890)	35.05 (890)	27	29.43 (748)	39.11 (993)
30.25	37.55 (954)	37.55 (954)	30	32.61 (828)	43.24 (1098)
33	43.74 (1111)	40.55 (1030)	33	35.74 (908)	47.99 (1219)
36	43.74 (1111)	43.55 (1106)	36.5	39.49 (1003)	52.55 (1335)
40.25	43.36 (1101)	58.30 (1481)			

Table 26: Fan Dimensions—Upblast Housed Fan Discharge

Unit Size (Fan Diameter)	A**	B**	C	G	H (min)
	in. (mm)	in. (mm)	in. (mm)	in. (mm)	in. (mm)
003 (9×4, 9×7 FC)*	38.00 (965)	26.00 (660)	32.00 (813)	8.49 (216)	8.18 (208)
004 (9×7, 9×9 FC)*	40.00 (1016)	30.00 (762)	32.00 (813)	8.49 (216)	8.18 (208)
006 (10.62 FC)*	52.00 (1321)	30.00 (762)	36.00 (914)	12.03 (306)	9.43 (240)
008 (15 FC)	58.00 (1473)	30.00 (762)	42.00 (1067)	13.76 (350)	12.50 (318)
008 (13.22 AF)	58.00 (1473)	34.00 (864)	40.00 (1016)	12.30 (312)	11.25 (286)
010 (18 FC)	64.00 (1626)	34.00 (864)	46.00 (1168)	15.14 (385)	14.62 (371)
010 (16.19 AF)	64.00 (1626)	36.00 (914)	46.00 (1168)	12.56 (319)	13.33 (339)
012 (18 FC)	66.00 (1676)	36.00 (914)	46.00 (1168)	15.17 (385)	14.62 (371)
012 (16.19 AF)	66.00 (1676)	42.00 (1067)	46.00 (1168)	12.56 (319)	13.33 (339)
014 (20 FC)	74.00 (1880)	42.00 (1067)	52.00 (1321)	14.07 (357)	16.00 (406)
014 (19.69 AF)	74.00 (1880)	42.00 (1067)	50.00 (1270)	14.54 (369)	15.78 (401)
017 (20 FC)	80.00 (2032)	42.00 (1118)	52.00 (1321)	14.07 (357)	16.00 (406)
017 (21.56 AF)	80.00 (2032)	46.00 (1168)	52.00 (1321)	14.16 (360)	17.09 (434)
021 (20 FC)	82.00 (2083)	46.00 (1168)	52.00 (1321)	14.07 (357)	16.00 (406)
021 (21.56 AF)	82.00 (2083)	52.00 (1321)	52.00 (1321)	14.16 (360)	17.09 (434)
025 (24.50 FC)*	86.00 (2184)	52.00 (1321)	60.00 (1524)	16.34 (415)	19.15 (486)
025 (24 AF)	86.00 (2184)	60.00 (1524)	58.00 (1473)	15.48 (393)	18.80 (478)
030 (24.50 FC)	98.00 (2489)	60.00 (1524)	60.00 (1524)	16.34 (415)	19.15 (486)
030 (24 AF)	98.00 (2489)	60.00 (1524)	58.00 (1473)	15.48 (393)	18.80 (478)
035 (24.50 FC)	102.00 (2591)	60.00 (1524)	60.00 (1524)	16.34 (415)	19.15 (486)
035 (24 AF)	102.00 (2591)	66.00 (1676)	58.00 (1473)	15.48 (393)	18.80 (478)
045 (24.50 FC)	106.00 (2692)	66.00 (1676)	60.00 (1524)	16.34 (415)	19.15 (486)
045 (24 AF)	106.00 (2692)	68.00 (1727)	58.00 (1473)	15.48 (393)	18.80 (478)
055 (24.50 FC)	106.00 (2692)	68.00 (1727)	60.00 (1524)	16.34 (415)	19.15 (486)
055 (24 AF)	106.00 (2692)	78.00 (1981)	58.00 (1473)	15.48 (393)	18.80 (478)
065 (40.25 AF)	136.00 (3454)	80.00 (2032)	92.00 (2337)	14.09 (358)	34.85 (987)
080 (40.25 AF)	136.00 (3454)	92.00 (2337)	92.00 (2337)	14.09 (358)	34.85 (987)
085 (40.25 AF)	136.00 (3454)	98.00 (2489)	92.00 (2337)	14.09 (358)	34.85 (987)
090 (40.25 AF)	136.00 (3454)	104.00 (2641)	92.00 (2337)	14.09 (358)	34.85 (987)

* Not available with vanes.

** These are the dimensions of the unit only. Curb-ready base adds 6" (152 mm) to the unit height. A standard base rail adds 8" (203 mm) to the width, and between 4" to 12" (102 mm to 305 mm) to the unit height. Height dimension does not include 2" roof cap seam.

DDPL Fan Array

Figure 27: Dimensional Data—Fan Array Four Fan Model

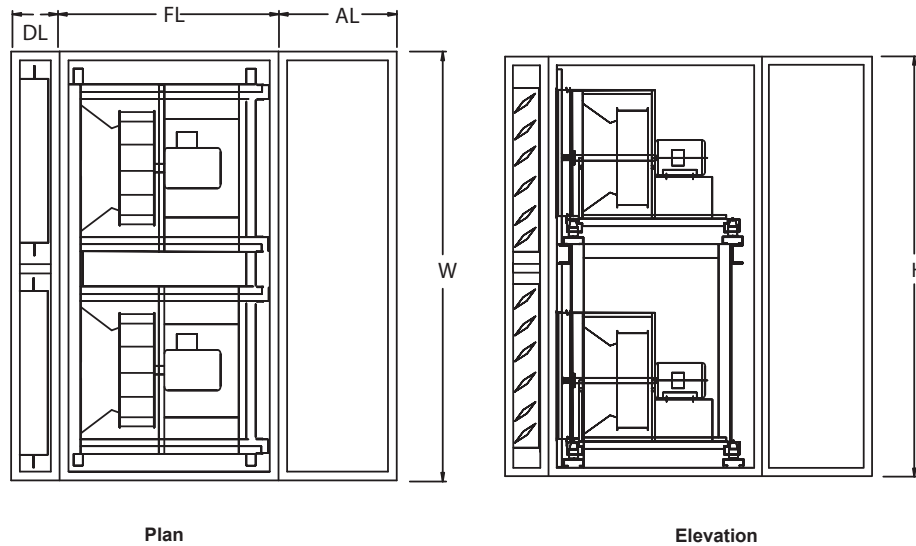

Table 27: Configuration Dimensions—Fan Array

Fan Configuration	Wheel Size in. (mm)	DL in. (mm)	FL in. (mm)	AL in. (mm)	H in. (mm)	W in. (mm)
1×3	12 (304.8)	14 (355.6)	28 (711.2)	24 (609.6)	36 (914.4)	104 (2641.6)
	15 (381)	14 (355.6)	32 (812.8)	24 (609.6)	38 (965.2)	110 (2794)
	18 (457.2)	14 (355.6)	40 (1016)	24 (609.6)	44 (1117.6)	128 (3251.2)
	20 (508)	14 (355.6)	42 (1066.8)	24 (609.6)	46 (1168.4)	140 (3556)
	22 (558.8)	14 (355.6)	42 (1066.8)	24 (609.6)	50 (1270)	146 (3708.4)
	24 (609.6)	14 (355.6)	46 (1168.4)	24 (609.6)	52 (1320.8)	158 (4013.2)
	27 (685.8)	14 (355.6)	48 (1219.2)	30 (762)	56 (1422.4)	170 (4318)
	30 (762)	14 (355.6)	54 (1371.6)	30 (762)	60 (1524)	182 (4622.8)
2×2	33 (838.2)	14 (355.6)	54 (1371.6)	30 (762)	60 (1524)	182 (4622.8)
	12 (304.8)	14 (355.6)	28 (711.2)	24 (609.6)	68 (1727.2)	70 (1778)
	15 (381)	14 (355.6)	32 (812.8)	24 (609.6)	72 (1828.8)	74 (1879.6)
	18 (457.2)	14 (355.6)	40 (1016)	24 (609.6)	84 (2133.6)	86 (2184.4)
	20 (508)	14 (355.6)	42 (1066.8)	24 (609.6)	88 (2235.2)	94 (2387.6)
	22 (558.8)	14 (355.6)	42 (1066.8)	24 (609.6)	96 (2438.4)	98 (2489.2)
	24 (609.6)	14 (355.6)	46 (1168.4)	24 (609.6)	100 (2540)	106 (2692.4)
	27 (685.8)	14 (355.6)	48 (1219.2)	30 (762)	108 (2743.2)	114 (2895.6)
2×3	30 (762)	14 (355.6)	54 (1371.6)	30 (762)	116 (2946.4)	122 (3098.8)
	33 (838.2)	14 (355.6)	54 (1371.6)	30 (762)	116 (2946.4)	122 (3098.8)
	12 (304.8)	14 (355.6)	28 (711.2)	24 (609.6)	68 (1727.2)	104 (2641.6)
	15 (381)	14 (355.6)	32 (812.8)	24 (609.6)	72 (1828.8)	110 (2794)
	18 (457.2)	14 (355.6)	40 (1016)	24 (609.6)	84 (2133.6)	128 (3251.2)
	20 (508)	14 (355.6)	42 (1066.8)	24 (609.6)	88 (2235.2)	140 (3556)
	22 (558.8)	14 (355.6)	42 (1066.8)	24 (609.6)	96 (2438.4)	146 (3708.4)
	24 (609.6)	14 (355.6)	46 (1168.4)	24 (609.6)	100 (2540)	158 (4013.2)
2×3	27 (685.8)	14 (355.6)	48 (1219.2)	30 (762)	108 (2743.2)	170 (4318)
	30 (762)	14 (355.6)	54 (1371.6)	30 (762)	116 (2946.4)	182 (4622.8)
	33 (838.2)	14 (355.6)	54 (1371.6)	30 (762)	116 (2946.4)	182 (4622.8)

Note: Other configurations available. Consult local Daikin sales representative for selection

* Minimum dimensions may reflect a variable geometric aspect ratio. Use the next size larger width or height for a standard aspect ratio.

ECM Fan Array

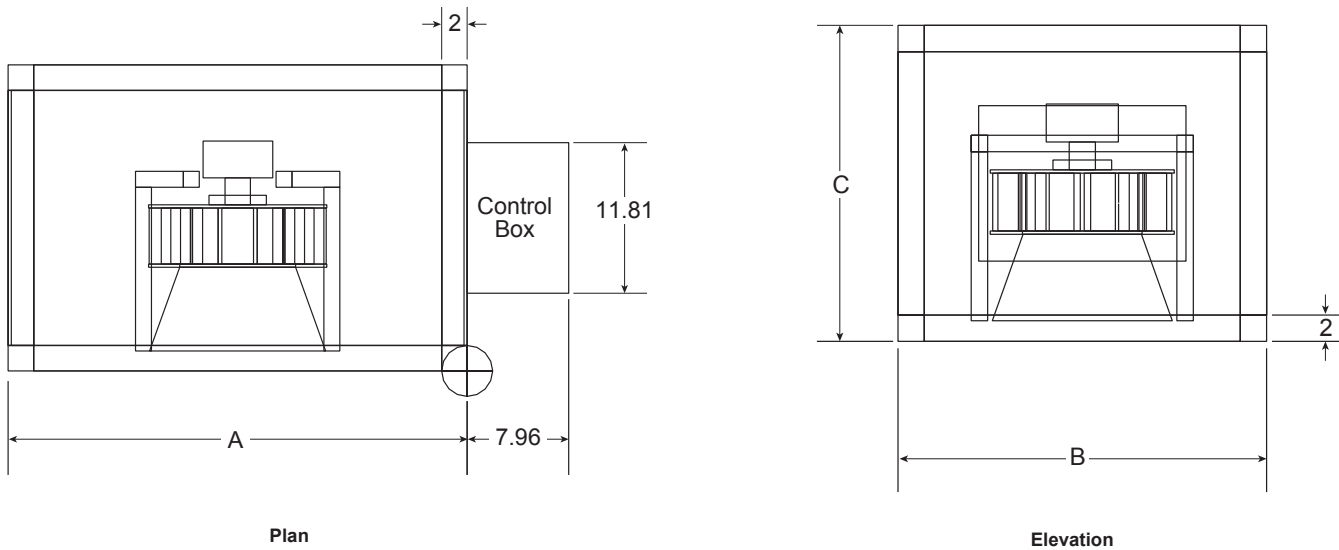

Table 28: ECM Fan Array Minimum Dimensions

Unit Size	Fan Diameter (mm)	A - In. (mm)	B - In. (mm)	C - In. (mm)
004	355	40 (1016)	30 (762)	24 (610)
006	355	52 (1321)	30 (762)	24 (610)
006	450	52 (1321)	30 (762)	30 (762)
008	355	58 (1473)	34 (864)	24 (610)
008	450	58 (1473)	34 (864)	30 (762)
010	355	64 (1626)	36 (914)	24 (610)
010	450	64 (1626)	36 (914)	30 (762)
012	355	66 (1676)	42 (1067)	24 (610)
012	450	66 (1676)	42 (1067)	30 (762)
014	355	74 (1880)	42 (1067)	24 (610)
014	450	74 (1880)	42 (1067)	30 (762)
017	355	80 (2032)	46 (1168)	24 (610)
017	450	80 (2032)	46 (1168)	30 (762)
021	355	82 (2083)	52 (1321)	24 (610)
021	450	82 (2083)	52 (1321)	30 (762)
025	355	86 (2184)	60 (1524)	24 (610)
025	450	86 (2184)	60 (1524)	30 (762)
030	355	98 (2489)	60 (1524)	24 (610)
030	450	98 (2489)	60 (1524)	30 (762)
035	355	102 (2591)	66 (1676)	24 (610)
035	450	102 (2591)	66 (1676)	30 (762)
040	355	116 (2946)	68 (1727)	24 (610)
040	450	116 (2946)	68 (1727)	30 (762)
050	355	120 (3048)	80 (2032)	24 (610)
050	450	120 (3048)	80 (2032)	30 (762)
065	355	136 (3454)	92 (2337)	24 (610)
065	450	136 (3454)	92 (2337)	30 (762)
080	355	136 (3454)	98 (2489)	24 (610)
080	450	136 (3454)	98 (2489)	30 (762)
085	355	136 (3454)	104 (2642)	24 (610)
085	450	136 (3454)	104 (2642)	30 (762)
090	355	136 (3454)	110 (2794)	24 (610)
090	450	136 (3454)	110 (2794)	30 (762)

Belt-Drive Plenum Fan Discharge

Figure 28: Dimensional Data—Belt-Drive Plenum Fan Discharge

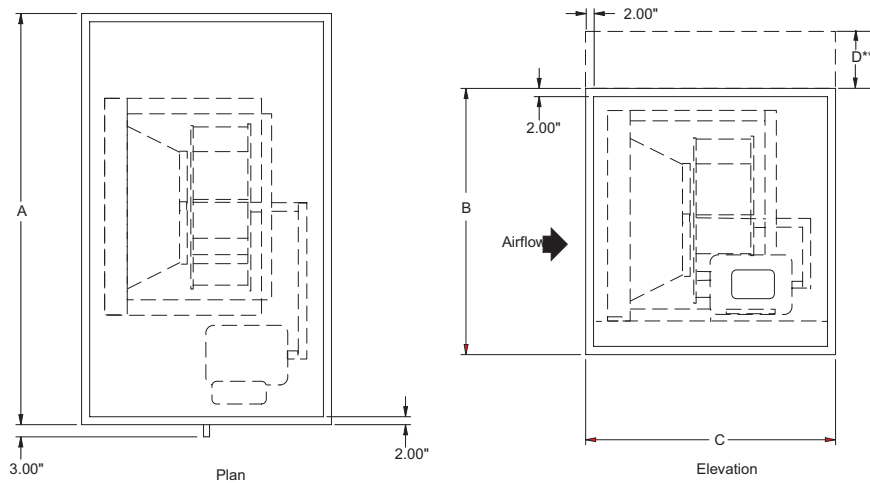

Table 29: Fan Dimensions—Belt-Drive Plenum Fan Discharge

Unit Size (Fan Diameter)	A*	B*	C	D**
	in. (mm)	in. (mm)	in. (mm)	in. (mm)
006 (13.5 AF)	52 (1321)	30 (762)	32 (813)	14 (356)
008 (13.5 AF)	58 (1473)	34 (864)	32 (813)	14 (356)
008 (15.0 AF)	58 (1473)	34 (864)	32 (813)	14 (356)
010 (16.0 AF)	64 (1626)	36 (914)	34 (864)	16 (406)
010 (18.0 AF)	64 (1626)	36 (914)	34 (864)	16 (406)
012 (20.0 AF)	66 (1676)	42 (1067)	36 (914)	18 (457)
012 (22.0 AF)	66 (1676)	42 (1067)	40 (1016)	18 (457)
014 (20.0 AF)	74 (1880)	42 (1067)	36 (914)	18 (457)
014 (22.0 AF)	74 (1880)	42 (1067)	40 (1016)	18 (457)
017 (24.0 AF)	80 (2032)	46 (1168)	42 (1067)	20 (508)
017 (27.0 AF)	80 (2032)	46 (1168)	44 (1118)	20 (508)
021 (27.0 AF)	82 (2083)	52 (1321)	44 (1118)	22 (559)
021 (30.0 AF)	82 (2083)	52 (1321)	48 (1219)	22 (559)
025 (30.0 AF)	86 (2184)	60 (1524)	48 (1219)	24 (610)
025 (33.0 AF)	86 (2184)	60 (1524)	50 (1270)	24 (610)
030 (33.0 AF)	98 (2489)	60 (1524)	50 (1270)	24 (610)
040 (40.0 AF)	116 (2946)	68 (1727)	52 (1321)	26 (660)
050 (44.0 AF)	120 (3048)	80 (2032)	56 (1422)	30 (762)
050 (49.0 AF)	120 (3048)	80 (2032)	60 (1524)	30 (762)
065 (54.0 AF)	136 (3454)	92 (2337)	64 (1626)	36 (914)
065 (60.0 AF)	136 (3454)	92 (2337)	68 (1727)	36 (914)
080 (54.0 AF)	136 (3454)	98 (2489)	64 (1626)	38 (965)
080 (60.0 AF)	136 (3454)	98 (2489)	68 (1727)	38 (965)
085 (54.0 AF)	136 (3454)	104 (2642)	64 (1626)	40 (1016)
040 (40.0 AF)	116 (2946)	68 (1727)	52 (1321)	26 (660)
050 (44.0 AF)	120 (3048)	80 (2032)	56 (1422)	30 (762)
050 (49.0 AF)	120 (3048)	80 (2032)	60 (1524)	30 (762)
065 (54.0 AF)	136 (3454)	92 (2337)	64 (1626)	36 (914)
065 (60.0 AF)	136 (3454)	92 (2337)	68 (1727)	36 (914)
080 (54.0 AF)	136 (3454)	98 (2489)	64 (1626)	38 (965)
085 (60.0 AF)	136 (3454)	104 (2642)	68 (1727)	40 (1016)
090 (54.0 AF)	136 (3454)	110 (2794)	64 (1626)	42 (1067)
090 (60.0 AF)	136 (3454)	110 (2794)	68 (1727)	42 (1067)

* These are the dimensions of the unit only. Curb-ready base adds 6" (152 mm) to the unit height. A standard base rail adds 8" (203 mm) to the width, and between 4" to 12" (102 mm to 305 mm) to the unit height.

** This value represents the height for an optional top plenum. Additional discharge openings include axial, top and single opening, opposite drive side, bottom single opening, split and removable panels. Use Daikin SelectTools software for more detailed dimensional information. Height dimension does not include 2" roof cap seam.

Direct-Drive Plenum Fan Discharge

Figure 29: Dimensional Data—Direct-Drive Plenum Fan Discharge

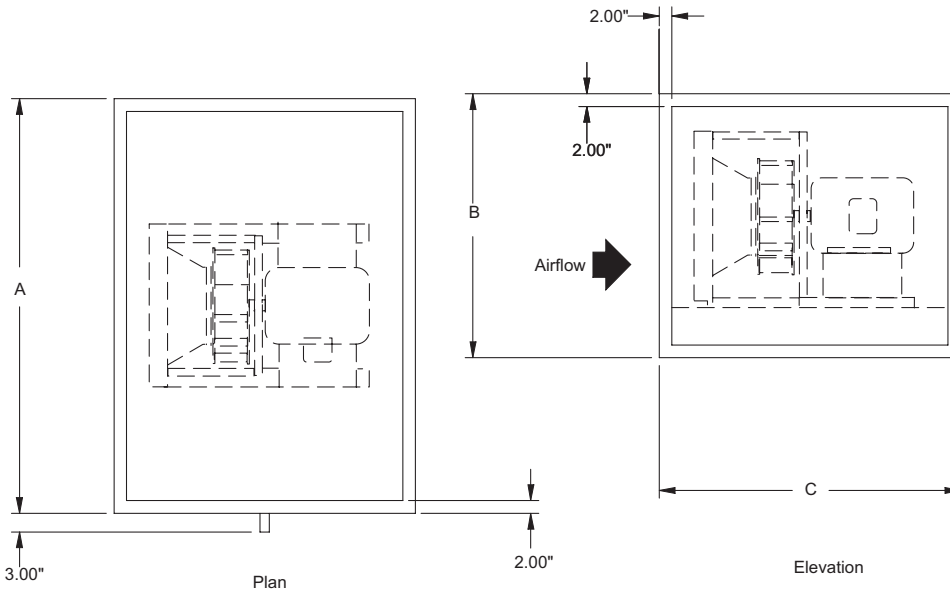

Table 30: Fan Dimensions—Direct-Drive Plenum Fan

Unit Size (Fan Diameter)	A*	B*	C**
	in. (mm)	in. (mm)	in. (mm)
004 (11 AF)	40 (1016)	30 (762)	28 (711)
004 (12 AF)	40 (1016)	30 (762)	30 (762)
006 (12 AF)	52 (1321)	30 (762)	30 (762)
006 (15 AF)	52 (1321)	30 (762)	34 (864)
008 (15 AF)	58 (1473)	34 (864)	34 (864)
008 (16 AF)	58 (1473)	34 (864)	40 (1016)
010 (16 AF)	64 (1626)	36 (914)	40 (1016)
010 (18 AF)	64 (1626)	36 (914)	44 (1118)
012 20 AF)	66 (1676)	42 (1067)	44 (1118)
012 (22 AF)	66 (1676)	42 (1067)	46 (1168)
014 20 AF)	74 (1880)	42 (1067)	44 (1118)
014 (22 AF)	74 (1880)	42 (1067)	46 (1168)
017 (24 AF)	80 (2032)	46 (1168)	50 (1270)
017 (27 AF)	80 (2032)	46 (1168)	56 (1422)
021 (27 AF)	82 (2083)	52 (1321)	56 (1422)
021 (30 AF)	82 (2083)	52 (1321)	56 (1422)
025 (30 AF)	86 (2184)	60 (1524)	56 (1422)
025 (36 AF)	68 (1727)	60 (1524)	62 (1575)
030 (30 AF)	98 (2489)	60 (1524)	56 (1422)
030 (36 AF)	98 (2489)	60 (1524)	62 (1575)
035 (33 AF)	102 (2591)	66 (1676)	60 (1524)
035 (36 AF)	102 (2591)	66 (1676)	62 (1575)
040 (36 AF)	116 (2946)	68 (1727)	62 (1575)
040 (40 AF)	116 (2946)	68 (1727)	70 (1778)
050 (44 AF)	120 (3048)	80 (2032)	74 (1880)
065 (44 AF)	136 (3454)	92 (2337)	74 (1880)
080 (44 AF)	136 (3454)	98 (2489)	74 (1880)
085 (44 AF)	136 (3454)	104 (2642)	74 (1880)
090 (44 AF)	136 (3454)	110 (2794)	74 (1880)

* These are the dimensions of the unit only. A standard base rail adds 8" (203 mm) to the width, and between 4" to 12" (102 mm to 305 mm) to the unit height. A 6" (152 mm) base rail is mandatory on unit sizes 025 to 065. An 8" (203 mm) base rail is mandatory on unit sizes 080 and larger.

** This value is dependent on motor frame size.

Dual Direct-Drive Plenum Fan Discharge

Figure 30: Dimensional Data—Dual Direct-Drive Plenum Fan Discharge

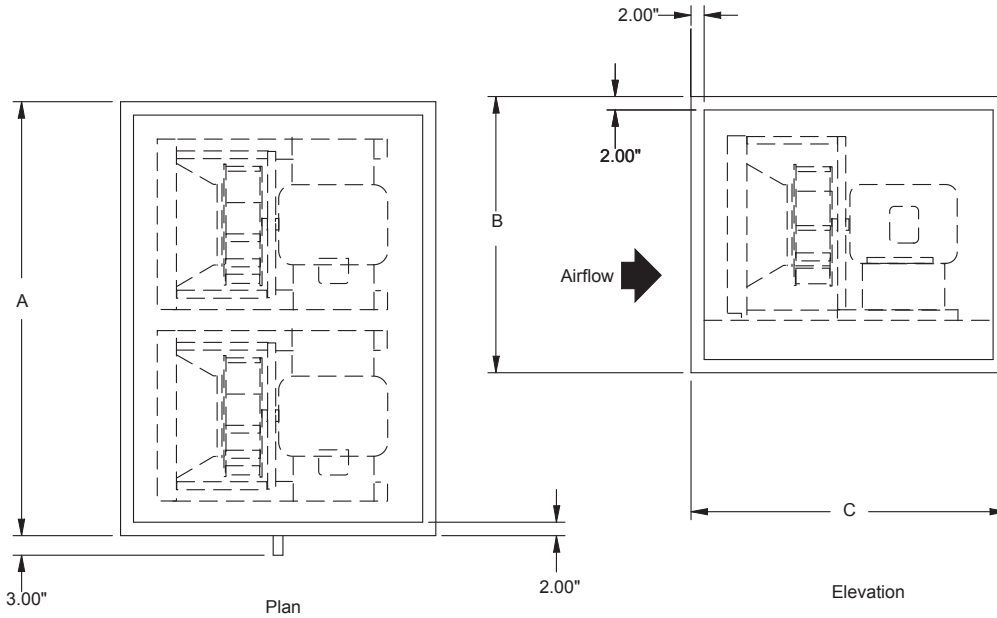

Table 31: Fan Dimensions—Dual Direct-Drive Plenum Fan

Unit Size (Fan Diameter)	A*	B*	C**
	in. (mm)	in. (mm)	in. (mm)
004 (11 AF)	80 (2032)	30 (762)	28 (711)
004 (12 AF)	80 (2032)	30 (762)	30 (762)
006 (12 AF)	104 (2642)	30 (762)	30 (762)
006 (15 AF)	104 (2642)	30 (762)	34 (864)
008 (15 AF)	116 (2946)	34 (864)	34 (864)
008 (16 AF)	116 (2946)	34 (864)	40 (1016)
010 (16 AF)	128 (3251)	36 (914)	40 (1016)
010 (18 AF)	128 (3251)	36 (914)	44 (1118)
012 (20 AF)	132 (3353)	42 (1067)	44 (1118)
012 (22 AF)	132 (3353)	42 (1067)	46 (1168)
014 (20 AF)	148 (3759)	42 (1067)	44 (1118)
014 (22 AF)	148 (3759)	42 (1067)	46 (1168)
017 (24 AF)	160 (4064)	46 (1168)	50 (1270)
017 (27 AF)	160 (4064)	46 (1168)	56 (1422)
021 (27 AF)	164 (4166)	52 (1321)	56 (1422)
021 (30 AF)	164 (4166)	52 (1321)	56 (1422)
025 (30 AF)	172 (4369)	60 (1524)	56 (1422)
025 (36 AF)	136 (3454)	60 (1524)	62 (1575)
030 (30 AF)	196 (4978)	60 (1524)	56 (1422)
030 (36 AF)	196 (4978)	60 (1524)	62 (1575)
035 (33 AF)	204 (5182)	66 (1676)	60 (1524)
035 (36 AF)	204 (5182)	66 (1676)	62 (1575)
040 (36 AF)	232 (5893)	68 (1727)	62 (1575)
040 (40 AF)	232 (5893)	68 (1727)	70 (1778)
050 (44 AF)	240 (6096)	80 (2032)	74 (1880)
065 (44 AF)	272 (6909)	92 (2337)	74 (1880)
080 (44 AF)	272 (6909)	98 (2489)	74 (1880)
085 (44 AF)	272 (6909)	104 (2642)	74 (1880)
090 (44 AF)	272 (6909)	110 (2794)	74 (1880)

* These are the dimensions of the unit only. A standard base rail adds 8" (203 mm) to the width, and between 4" to 12" (102 mm to 305 mm) to the unit height. A 6" (152 mm) base rail is mandatory on unit sizes 025 to 065. An 8" (203 mm) base rail is mandatory on unit sizes 080 and larger.

** This value is dependent on motor frame size.

Inline Fan Discharge

Figure 31: Dimensional Data—Inline Fan Discharge

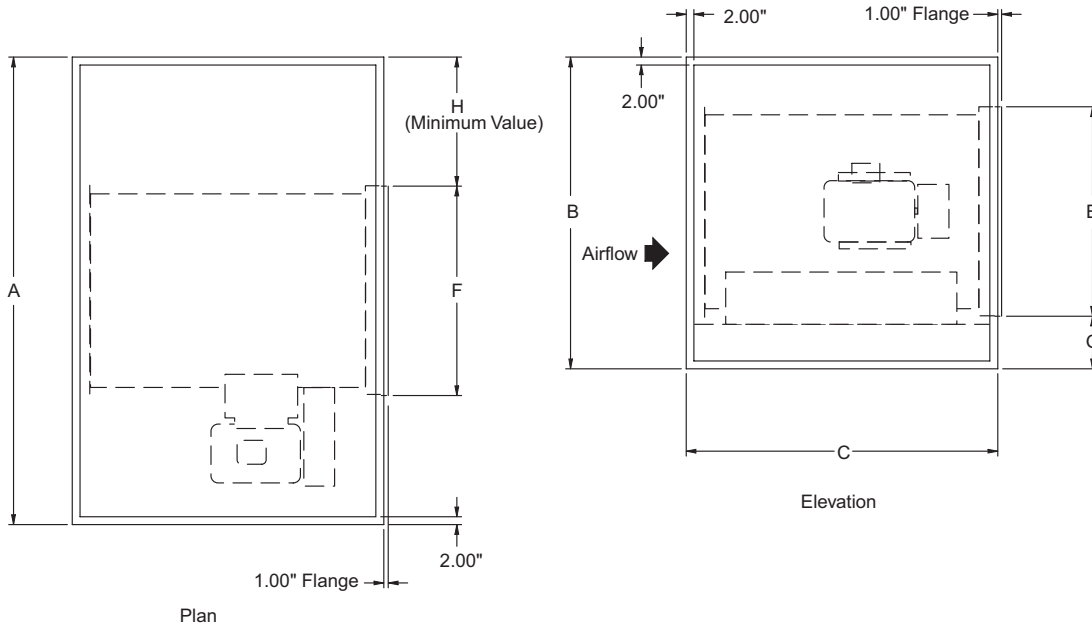

Table 32: Fan Dimensions—Inline Fan Discharge

Unit Size (Fan Diameter)	A*	B*	C	E	F	G	H (min)
	in. (mm)	in. (mm)	in. (mm)	in. (mm)	in. (mm)	in. (mm)	in. (mm)
012 (150 Inline)	66 (1676)	42 (1067)	42 (1067)	27.8 (706)	25.8 (655)	8.1 (206)	20.1 (511)
012 (165 Inline)	66 (1676)	42 (1067)	44 (1118)	29.8 (757)	27.8 (706)	8.1 (206)	18.1 (460)
014 (150 Inline)	74 (1880)	42 (1067)	42 (1067)	27.8 (706)	25.8 (655)	8.1 (206)	24.1 (612)
014 (165 Inline)	74 (1880)	42 (1067)	44 (1118)	29.8 (757)	27.8 (706)	8.1 (206)	22.1 (561)
017 (165 Inline)	80 (2032)	46 (1168)	44 (1118)	29.8 (757)	27.8 (706)	8.1 (206)	26.1 (663)
017 (182 Inline)	80 (2032)	46 (1168)	48 (1219)	31.8 (808)	31.8 (808)	8.1 (206)	24.1 (612)
021 (200 Inline)	82 (2083)	52 (1321)	50 (1270)	33.8 (859)	35.8 (909)	8.1 (206)	14.1 (358)
021 (222 Inline)	82 (2083)	52 (1321)	54 (1372)	35.8 (909)	35.8 (909)	10.1 (257)	16.1 (409)
025 (245 Inline)	86 (2184)	60 (1524)	58 (1473)	41.8 (1062)	39.8 (1011)	8.1 (206)	16.1 (409)
025 (270 Inline)	86 (2184)	60 (1524)	64 (1626)	43.8 (1113)	43.8 (1113)	12.1 (307)	14.1 (358)
030 (245 Inline)	98 (2489)	60 (1524)	58 (1473)	41.8 (1062)	39.8 (1011)	8.1 (206)	28.1 (714)
030 (270 Inline)	98 (2489)	60 (1524)	64 (1626)	43.8 (1113)	43.8 (1113)	12.1 (307)	20.1 (511)
035 (270 Inline)	102 (2591)	66 (1676)	64 (1626)	43.8 (1113)	43.8 (1113)	12.1 (307)	28.1 (714)
035 (300 Inline)	102 (2591)	66 (1676)	70 (1778)	47.8 (1214)	47.8 (1214)	12.1 (307)	20.1 (511)
045 (300 Inline)	106 (2692)	78 (1981)	70 (1778)	47.8 (1214)	47.8 (1214)	12.1 (307)	20.1 (511)
045 (333 Inline)	106 (2692)	78 (1981)	76 (1930)	51.8 (1316)	51.8 (1316)	12.1 (307)	20.1 (511)
055 (333 Inline)	106 (2692)	90 (2286)	76 (1930)	51.8 (1316)	51.8 (1316)	12.1 (307)	20.1 (511)
055 (365 Inline)	106 (2692)	90 (2286)	82 (2082)	57.8 (1468)	57.8 (1468)	12.1 (307)	30.1 (765)
065 (402 Inline)	136 (3454)	92 (2337)	90 (2286)	63.8 (1621)	63.8 (1621)	12.1 (307)	36.1 (917)
065 (445 Inline)	136 (3454)	92 (2337)	96 (2438)	69.8 (1773)	69.8 (1773)	12.1 (307)	32.1 (815)
080 (402 Inline)	136 (3454)	98 (2489)	90 (2286)	63.8 (1621)	63.8 (1621)	12.1 (307)	36.1 (917)
080 (445 Inline)	136 (3454)	98 (2489)	96 (2438)	69.8 (1773)	69.8 (1773)	12.1 (307)	32.1 (815)
085 (402 Inline)	136 (3454)	104 (2642)	90 (2286)	63.8 (1621)	63.8 (1621)	12.1 (307)	36.1 (917)
085 (445 Inline)	136 (3454)	104 (2642)	96 (2438)	69.8 (1773)	69.8 (1773)	12.1 (307)	32.1 (815)
090 (402 Inline)	136 (3454)	110 (2794)	90 (2286)	63.8 (1621)	63.8 (1621)	12.1 (307)	36.1 (917)
090 (445 Inline)	136 (3454)	110 (2794)	96 (2438)	69.8 (1773)	69.8 (1773)	12.1 (307)	32.1 (815)

* These are the dimensions of the unit only. Curb-ready base adds 6" (152 mm) to the unit height. A standard base rail adds 8" (203 mm) to the width, and between 4" to 12" (102 mm to 305 mm) to the unit height. Height dimension does not include 2" roof cap seam.

Cooling Coil Section

The single cooling coil section is available in numerous depths. This provides the option of varying the amount of space downstream from the coil for access to inspect and clean the coil and drain pan. When using a single bank of coils, the 18" deep section holds up to a 4-row water or DX coil.

Also available are staggered cooling coils. The staggered arrangement maximizes the cooling coil face area by providing two banks of coils. These two coils are not stacked, but are

staggered in the direction of airflow. This configuration does require more section depth in the direction of airflow. Staggered coils are only available on unit sizes 025 and larger. The section depth required varies between 30" to 54". This depends on the unit size and number of rows in the coil.

Standard base units require a minimum cooling coil vestibule length of 12". Curb-ready base units require a minimum cooling coil vestibule length of 18".

Figure 32: Dimensional Data—Cooling Coil Section

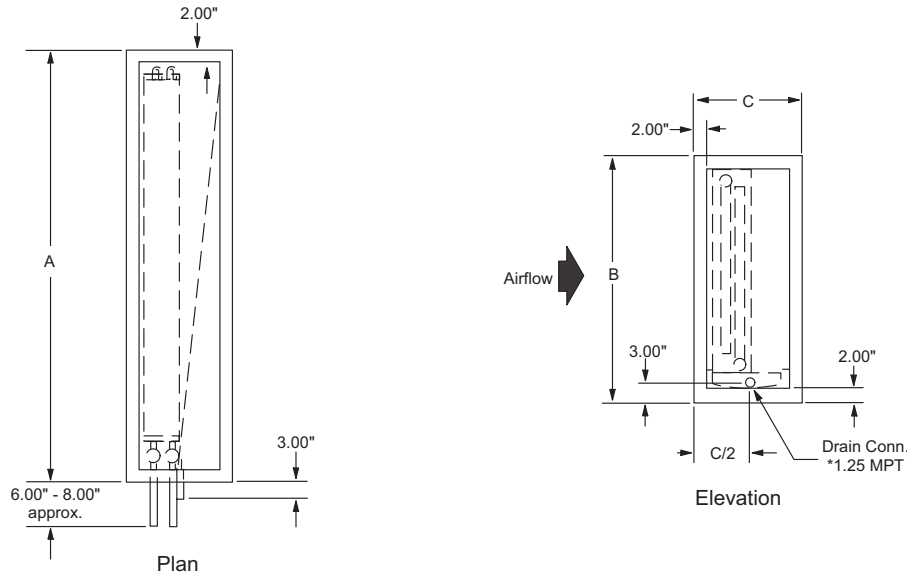

Table 33: Dimensions—Cooling Coil Section

Unit Size	A (Large, Medium Coils)*	A (Extended Coils)*	B*	C (Available All Sizes)**
	in. (mm)	in. (mm)	in. (mm)	in. (mm)
003	38 (965)	44 (1118)	26 (660)	18.0 (457) to 54.0 (1372) In 2" increments
004	40 (1016)	46 (1168)	30 (762)	
006	52 (1321)	58 (1473)	30 (762)	
008	58 (1473)	64 (1626)	34 (864)	
010	64 (1626)	70 (1778)	36 (914)	
012	66 (1676)	72 (1829)	42 (1067)	
014	74 (1880)	80 (2032)	42 (1067)	
017	80 (2032)	86 (2184)	46 (1168)	
021	82 (2083)	88 (2235)	52 (1321)	
025	86 (2184)	N/A	60 (1524)	
030	98 (2489)	N/A	60 (1524)	
035	102 (2591)	N/A	66 (1676)	
045	106 (2692)	N/A	78 (1981)	
055	106 (2692)	N/A	90 (2286)	
065	136 (3454)	N/A	92 (2337)	
080	136 (3454)	N/A	98 (2489)	
085	136 (3454)	N/A	104 (2642)	
090	136 (3454)	N/A	110 (2794)	

* These are the dimensions of the unit only. Curb-ready base adds 6" (152 mm) to the unit height. A standard base rail adds 8" (203 mm) to the width, and between 4" to 12" (102 mm to 305 mm) to the unit height

** All cooling coil lengths listed are available for any unit size (003 to 055). Height dimension does not include 2" roof cap seam.

Combination Cooling and Reheat Coil Section

The combination cooling and reheat coil section is available in numerous depths. This provides the option of varying the amount of space between the cooling coil and reheat coil for access to inspect and clean the coil and drain pan. All reheat and most cooling coils are arranged in a single bank, which can be 1, 2 or 3 coils high. When using a single bank of cooling coils, the 24" deep section holds up to a 4-row water or DX coil, and a 1-row or 2-row heating coil. A 36" deep section holds a 12-row water coil and a 1 or 2-row reheat coil.

Also available are staggered cooling coils. The staggered arrangement maximizes the cooling coil face area by providing

two banks of coils. These two coils are not stacked, but are staggered in the direction of airflow. This configuration does require more section depth in the direction of airflow. Staggered coils are available only on unit sizes 025 and larger. The section depth required varies between 30" to 54". This depends on the unit size and number of rows in the coil.

Standard base units require a minimum combination coil vestibule length of 12". Curb-ready base units require a minimum combination coil length of 16" and a minimum coil vestibule length of 18".

Figure 33: Dimensional Data—Combination Cooling and Reheat Coil Section

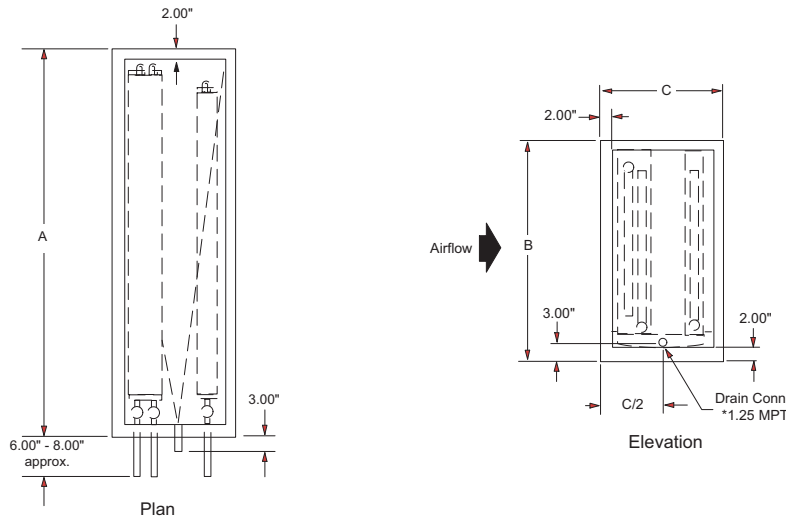

Table 34: Dimensions—Combination Cooling and Reheat Coil

Unit Size	A (Large, Medium Coils)*	A (Extended Coils)*	B*	C (Available All Sizes)**
	in. (mm)	in. (mm)	in. (mm)	in. (mm)
003	38 (965)	44 (1118)	26 (660)	18.0 (457) to 54.0 (1372) In 2" increments
004	40 (1016)	46 (1168)	30 (762)	
006	52 (1321)	58 (1473)	30 (762)	
008	58 (1473)	64 (1626)	34 (864)	
010	64 (1626)	70 (1778)	36 (914)	
012	66 (1676)	72 (1829)	42 (1067)	
014	74 (1880)	80 (2032)	42 (1067)	
017	80 (2032)	86 (2184)	46 (1168)	
021	82 (2083)	88 (2235)	52 (1321)	
025	86 (2184)	N/A	60 (1524)	
030	98 (2489)	N/A	60 (1524)	
035	102 (2591)	N/A	66 (1676)	
045	106 (2692)	N/A	78 (1981)	
055	106 (2692)	N/A	90 (2286)	
065	136 (3454)	N/A	92 (2337)	
080	136 (3454)	N/A	98 (2489)	
085	136 (3454)	N/A	104 (2642)	
090	136 (3454)	N/A	110 (2794)	

* These are the dimensions of the unit only. Curb-ready base adds 6" (152 mm) to the unit height. A standard base rail adds 8" (203 mm) to the width, and between 4" to 12" (102 mm to 305 mm) to the unit height

** All cooling coil lengths listed are available for any unit size (003 to 055). Height dimension does not include 2" roof cap seam.

Heating Coil Section

Figure 34: Dimensional Data—Heating Coil Section

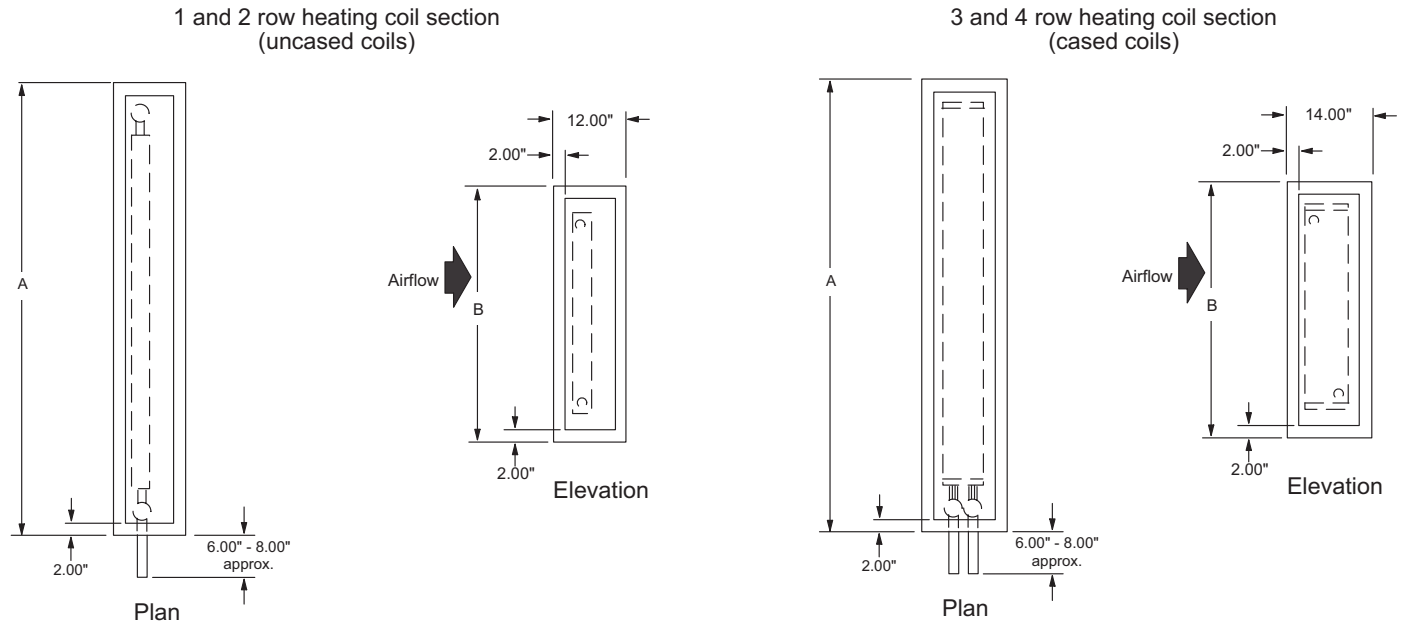

NOTE: 1.25 MPT drain connections are available as an option for heating coil sections. Standard base units require a minimum heating coil vestibule length of 12". Curb-ready base units require a heating coil minimum length of 16", and a minimum heating coil vestibule length of 18".

Table 35: Dimensions—Heating Coil Section*

Unit Size	A	B
	in. (mm)	in. (mm)
003	38 (965)	26 (660)
004	40 (1016)	30 (762)
006	52 (1321)	30 (762)
008	58 (1473)	34 (864)
010	64 (1626)	36 (914)
012	66 (1676)	42 (1067)
014	74 (1880)	42 (1067)
017	80 (2032)	46 (1168)
021	82 (2083)	52 (1321)
025	86 (2184)	60 (1524)
030	98 (2489)	60 (1524)
035	102 (2591)	66 (1676)
045	106 (2692)	78 (1981)
055	106 (2692)	90 (2286)
065	136 (3454)	92 (2337)
080	136 (3454)	98 (2489)
085	136 (3454)	104 (2642)
090	136 (3454)	110 (2794)

* These are the dimensions of the unit only. A curb-ready base rail adds 6" (152 mm) to the unit height. A standard base rail adds 8" (203 mm) to the width and between 4" to 12" (102 mm to 305 mm) to the unit height. A base rail is mandatory on unit sizes 025 to 065 and adds a minimum of 6" (152 mm) to the unit height. Unit sizes greater than 080 require a base rail that adds a minimum of 8" (203 mm to 305 mm) to the unit height.

Side Load Flat and Angular Filter Section

Figure 35: Dimensional Data—Side Load Flat and Angular Filter Section

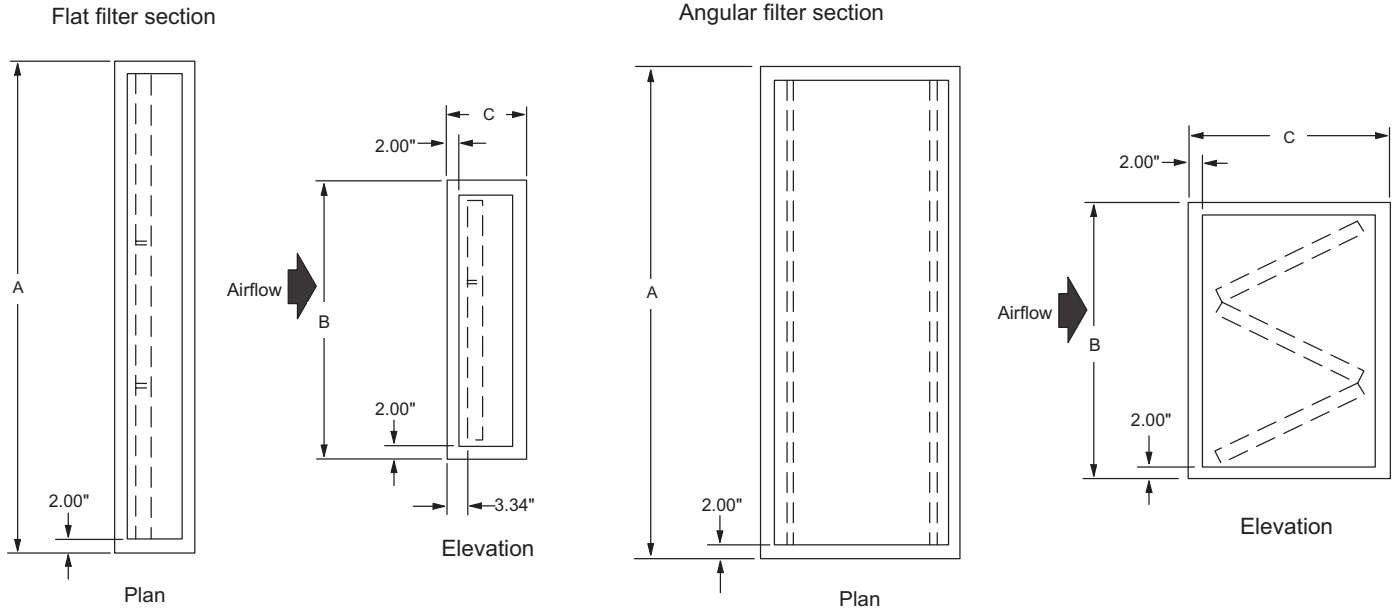

Table 36: Dimensions—Side Load Flat and Angular Filter Section

Unit Size	A*	B*	C		
			2" and 4" Flat Filter	2" Angular Filter	4" Angular Filter
	in. (mm)	in. (mm)	in. (mm)	in. (mm)	in. (mm)
003	38 (965)	28 (711)	12 (305)	32 (813)	N/A
004	40 (1016)	32 (813)	12 (305)	30 (762)	N/A
006	52 (1321)	32 (813)	12 (305)	30 (762)	N/A
008	58 (1473)	34 (864)	12 (305)	30 (762)	32 (813)
010	64 (1626)	38 (965)	12 (305)	30 (762)	32 (813)
012	66 (1676)	44 (1118)	12 (305)	30 (762)	32 (813)
014	74 (1880)	44 (1118)	12 (305)	30 (762)	32 (813)
017	80 (2032)	46 (1168)	12 (305)	30 (762)	32 (813)
021	82 (2083)	52 (1321)	12 (305)	30 (762)	32 (813)
025	86 (2184)	60 (1524)	12 (305)	32 (813)	32 (813)
030	98 (2489)	60 (1524)	12 (305)	32 (813)	32 (813)
035	102 (2591)	66 (1676)	12 (305)	32 (813)	32 (813)
045	106 (2692)	78 (1981)	12 (305)	32 (813)	32 (813)
055	106 (2692)	90 (2286)	12 (305)	32 (813)	32 (813)
065	136 (3454)	92 (2337)	12 (305)	32 (813)	32 (813)
080	136 (3454)	98 (2489)	12 (305)	32 (813)	32 (813)
085	136 (3454)	104 (2642)	12 (305)	32 (813)	32 (813)
090	136 (3454)	110 (2794)	12 (305)	32 (813)	32 (813)

* These are the dimensions of the unit only. Curb-ready base adds 6" (152 mm) to the unit height. A standard base rail adds 8" (203 mm) to the width, and between 4" to 12" (102 mm to 305 mm) to the unit height. Height dimension does not include 2" roof cap seam.

Side Load Cartridge and Bag Filter Section

Figure 36: Dimensional Data—Side Load Cartridge and Bag Filter Section

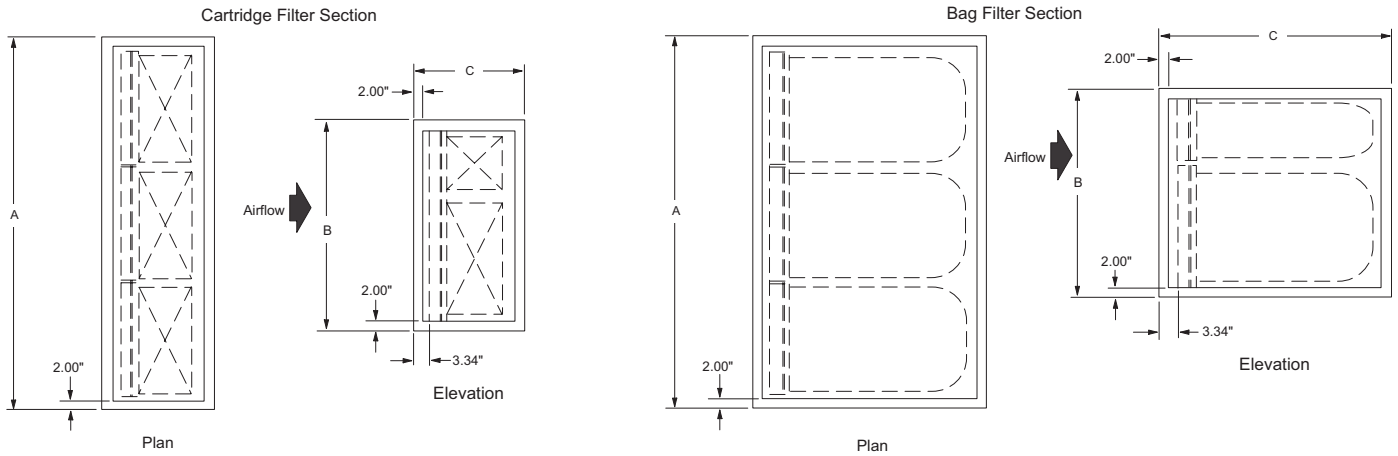

Table 37: Dimensions—Side Load Cartridge and Bag Filter

Unit Size	A*	B*
	in. (mm)	in. (mm)
003	38 (965)	28 (711)
004	40 (1016)	32 (813)
006	52 (1321)	32 (813)
008	58 (1473)	34 (864)
010	64 (1626)	38 (965)
012	66 (1676)	44 (1118)
014	74 (1880)	44 (1118)
017	80 (2032)	46 (1168)
021	82 (2083)	52 (1321)
025	86 (2184)	60 (1524)
030	98 (2489)	60 (1524)
035	102 (2591)	66 (1676)
045	106 (2692)	78 (1981)
055	106 (2692)	90 (2286)
065	136 (3454)	92 (2337)
080	136 (3454)	98 (2489)
085	136 (3454)	104 (2642)
090	136 (3454)	110 (2794)

* Dimensions of unit only. Curb-ready base adds 6" (152 mm) to the unit height. A standard base rail adds 8" (203 mm) to the width, and between 4" to 12" (102mm to 305 mm) to the unit height. A base rail is mandatory on unit sizes 025 and 065 and adds a minimum of 6" (152 mm) to the unit height. Unit sizes greater than 080 require a base rail that adds a minimum of 8" (203 mm) to the unit height. Height dimension does not include 2" roof cap seam.

Table 38: Dimensions—Cartridge and Bag Filters

Filter Type	C—All Sizes
Cartridge	in. (mm)
4" with 2" Pre	14 (356)
4" with 4" Pre	16 (406)
12" with 2" Pre	22 (559)
12" with 4" Pre	24 (610)
Bag	in. (mm)
12" with 2" Pre	18 (457)
12" with 4" Pre	20 (508)
15" with 2" Pre	22 (559)
15" with 4" Pre	24 (610)
19" with 2" Pre	26 (660)
19" with 4" Pre	28 (711)
22" with 2" Pre	28 (711)
22" with 4" Pre	30 (762)
30" with 2" Pre	36 (914)
30" with 4" Pre	38 (965)
36" with 2" Pre	42 (1067)
36" with 4" Pre	44 (1118)

Front Load Cartridge and Bag Filter Section

Figure 37: Dimensional Data—Front Load Cartridge and Bag Filter Section

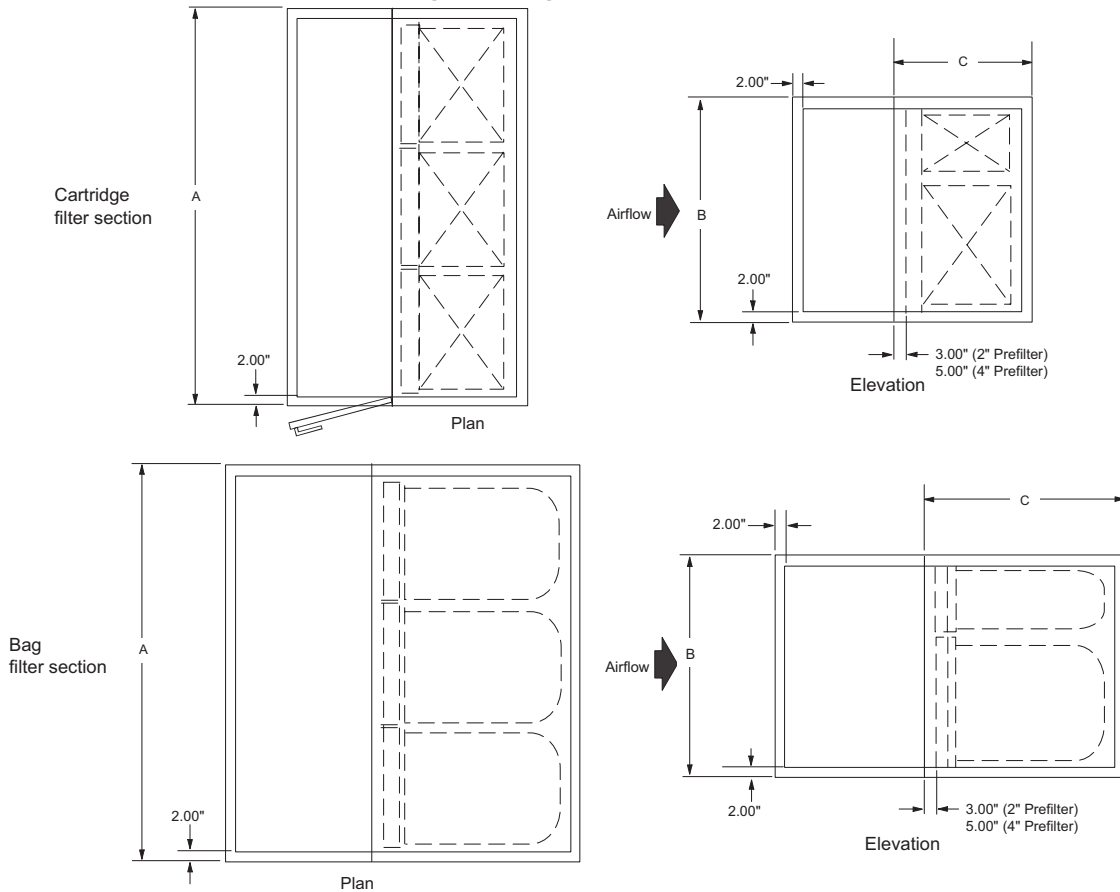

NOTE: An upstream plenum with tread plate is required on all front load filter sections.

Table 39: Front Load Cartridge Bag Filter Section

Unit Size	A*	B*
	in. (mm)	in. (mm)
003	38 (965)	28 (711)
004	40 (1016)	32 (813)
006	52 (1321)	32 (813)
008	58 (1473)	34 (864)
010	64 (1626)	38 (965)
012	66 (1676)	44 (1118)
014	74 (1880)	44 (1118)
017	80 (2032)	46 (1168)
021	82 (2083)	52 (1321)
025	86 (2184)	60 (1524)
030	98 (2489)	60 (1524)
035	102 (2591)	66 (1676)
045	106 (2692)	78 (1981)
055	106 (2692)	90 (2286)
065	136 (3454)	92 (2337)
080	136 (3454)	98 (2489)
085	136 (3454)	104 (2642)
090	136 (3454)	110 (1795)

* Dimensions of unit only. Curb-ready base adds 6" (152 mm) to the unit height. A standard base rail adds 8" (203 mm) to width and between 4" to 12" (102 mm to 305 mm) to unit height. Height dimension does not include 2" roof cap seam.

Table 40: Filter Dimensions

Filter Type	C—All Sizes
Cartridge	in. (mm)
4" with 2" Pre	12 (305)
4" with 4" Pre	12 (305)
12" with 2" Pre	16 (406)
12" with 4" Pre	16 (406)
Bag	in. (mm)
12" with 2" Pre	16 (406)
12" with 4" Pre	16 (406)
15" with 2" Pre	20 (508)
15" with 4" Pre	20 (508)
19" with 2" Pre	24 (610)
19" with 4" Pre	24 (610)
22" with 2" Pre	26 (660)
22" with 4" Pre	26 (660)
30" with 2" Pre	34 (864)
30" with 4" Pre	34 (864)
36" with 2" Pre	40 (1016)
36" with 4" Pre	40 (1016)

Blenders

Figure 38: Dimensional Data—Blenders

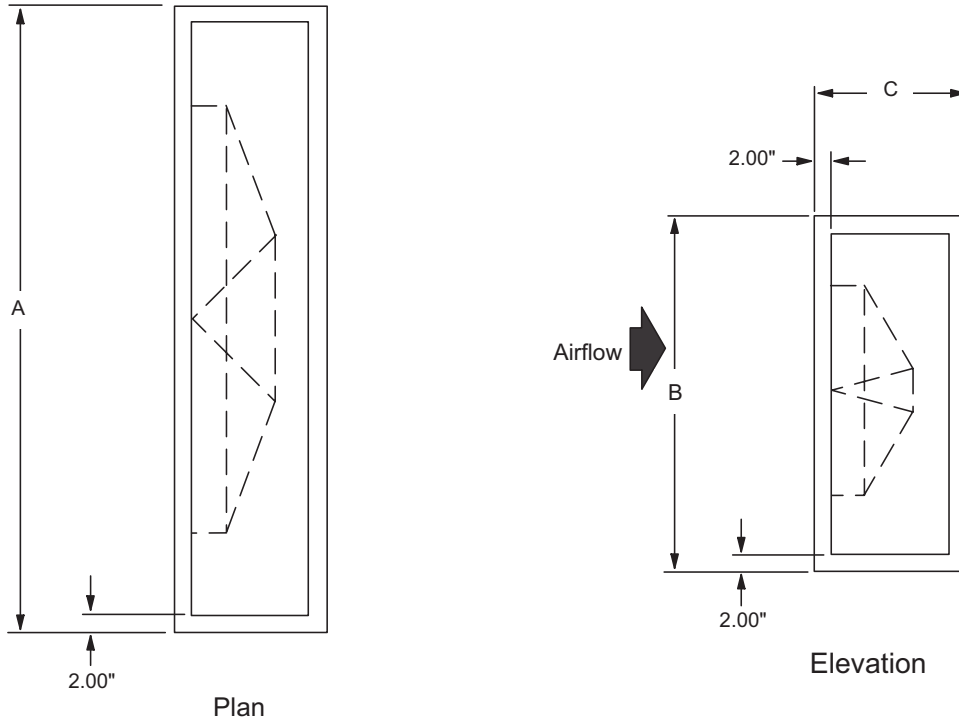

NOTE: The depth of an air mixer section varies depending on components adjacent to the mixing device. The catalog dimensions shown are for a two-blender system except sizes 040 to 090, which are three-blender systems. For applications other than this, the depth dimension varies. Use Skyline software for more detailed dimensional information.

Table 41: Dimensions—Blender Product Series IV

Unit Size	A*	B*	C
	in. (mm)	in. (mm)	in. (mm)
003	38 (965)	26 (660)	N/A
004	40 (1016)	30 (762)	12 (305)
006	52 (1321)	30 (762)	14 (356)
008	58 (1473)	34 (864)	16 (406)
010	64 (1626)	36 (914)	18 (457)
012	66 (1676)	42 (1067)	20 (508)
014	74 (1880)	42 (1067)	22 (559)
017	80 (2032)	46 (1168)	24 (610)
021	82 (2083)	52 (1321)	28 (711)
025	86 (2184)	60 (1524)	32 (813)
030	98 (2489)	60 (1524)	34 (864)
035	102 (2591)	66 (1676)	36 (914)
045	106 (2692)	78 (1981)	48 (1219)
055	106 (2692)	90 (2286)	58 (1473)
065	136 (3454)	92 (2337)	52 (1321)
080	136 (3454)	98 (3489)	54 (1372)
085	136 (3454)	104 (2642)	56 (1422)
090	136 (3454)	110 (2794)	58 (1473)

* These are the dimensions of the unit only. Curb-ready base adds 6" (152 mm) to the unit height. A standard base rail adds 8" (203 mm) to the width, and between 4" to 12" (102 mm to 305 mm) to the unit height.

Table 42: Dimensions—Kees Blender

Unit Size	A**	B*	C
	in. (mm)	in. (mm)	in. (mm)
003	38 (965)	26 (660)	N/A
004	40 (1016)	30 (762)	N/A
006	52 (1321)	30 (762)	22 (559)
008	58 (1473)	34 (864)	24 (610)
010	64 (1626)	36 (914)	26 (660)
012	66 (1676)	42 (1067)	28 (711)
014	74 (1880)	42 (1067)	30 (762)
017	80 (2032)	46 (1168)	32 (813)
021	82 (2083)	52 (1321)	36 (914)
025	86 (2184)	60 (1524)	38 (965)
030	98 (2489)	60 (1524)	40 (1016)
035	102 (2591)	66 (1676)	42 (1067)
045	106 (2692)	78 (1981)	52 (1321)
055	106 (2692)	90 (2286)	54 (1372)
065	136 (3454)	92 (2337)	46 (1168)
080	136 (3454)	98 (3489)	56 (1422)
085	136 (3454)	104 (2642)	58 (1473)
090	136 (3454)	110 (2794)	58 (1473)

* These are the dimensions of the unit only. Curb-ready base adds 6" (152 mm) to the unit height. A standard base rail adds 8" (203 mm) to the width, and between 4" to 12" (102 mm to 305 mm) to the unit height.

** All values represent Kees blenders located after filters. A 6" (152 mm) base rail is mandatory on unit sizes 025 to 065. An 8" (203 mm) base rail is mandatory on all sizes 080 and larger. Height dimension does not include 2" roof cap seam.

Mixing Box and Combination Filter Mixing Box

Figure 39: Dimensional Data—Mixing Box and Combination Filter Mixing Box

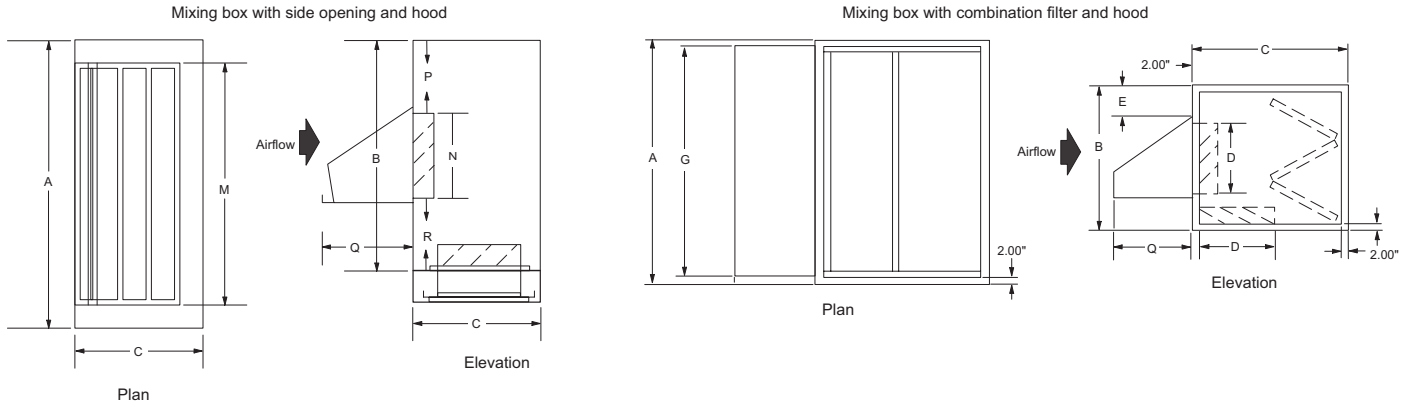

NOTE: Dampers can be located in the top, bottom, and end of the section. Top and bottom fresh air dampers are not available if hoods are selected.

Table 43: Dimensions—Mixing Box and Combination Filter Mixing Box

Unit Size	A* in. (mm)	B* in. (mm)	C					D in. (mm)	E in. (mm)	G in. (mm)	H in. (mm)	J in. (mm)	K in. (mm)	M in. (mm)	N in. (mm)	P in. (mm)	Q in. (mm)	R in. (mm)
			Mixing Box Only	w/ 2" Flat Filter	w/ 4" Flat Filter	w/ 2" Angle Filter	w/ 4" Angle Filter											
			in. (mm)	in. (mm)	in. (mm)	in. (mm)	in. (mm)											
003	38 (965)	28 (711)	20 (508)	24 (610)	26 (660)	42 (1067)	46 (1168)	16 (406)	10 (254)	34 (864)	16.3 (414)	40 (1016)	16 (406)	34 (864)	16 (406)	2 (51)	16.3 (414)	10 (254)
004	40 (1016)	32 (813)	20 (508)	24 (610)	26 (660)	42 (1067)	46 (1168)	16 (406)	14 (356)	36 (914)	21.7 (551)	32 (813)	20 (508)	36 (914)	16 (406)	2 (51)	16.3 (414)	14 (356)
006	52 (1321)	32 (813)	20 (508)	24 (610)	26 (660)	42 (1067)	46 (1168)	16 (406)	14 (356)	48 (1219)	27.1 (688)	48 (1219)	20 (508)	32 (813)	16 (406)	2 (51)	16.3 (414)	14 (356)
008	58 (1473)	34 (864)	20 (508)	24 (610)	26 (660)	42 (1067)	46 (1168)	16 (406)	10 (254)	54 (1372)	27.1 (688)	46 (1168)	24 (610)	38 (965)	16 (406)	8 (203)	16.3 (414)	10 (254)
010	64 (1626)	38 (965)	22 (559)	26 (660)	28 (711)	44 (1118)	48 (1219)	18 (457)	8 (203)	60 (1524)	29.8 (757)	48 (1219)	26 (660)	44 (1118)	18 (457)	10 (254)	19 (483)	10 (254)
012	66 (1676)	44 (1118)	24 (610)	28 (711)	30 (762)	46 (1168)	50 (1270)	20 (508)	10 (254)	70 (1778)	37.9 (963)	44 (1118)	32 (813)	46 (1175)	20 (508)	12 (305)	21.7 (551)	12 (305)
014	74 (1880)	44 (1118)	24 (610)	28 (711)	30 (762)	46 (1168)	50 (1270)	20 (508)	10 (254)	70 (1778)	37.9 (963)	50 (1270)	32 (813)	54 (1372)	20 (508)	12 (305)	21.7 (551)	12 (305)
017	80 (2032)	46 (1168)	26 (660)	30 (762)	32 (813)	48 (1219)	52 (1321)	22 (559)	12 (305)	76 (1930)	21.6 (549)	52 (1321)	36 (914)	60 (1524)	22 (559)	12 (305)	24.4 (620)	12 (305)
021	82 (2083)	52 (1321)	30 (762)	34 (864)	36 (914)	52 (1321)	56 (1422)	26 (660)	14 (356)	78 (1981)	25.6 (650)	52 (1321)	42 (1067)	62 (1575)	26 (660)	12 (305)	29.8 (757)	12 (305)
025	86 (2184)	60 (1524)	32 (813)	36 (914)	38 (965)	54 (1372)	58 (1473)	28 (711)	16 (406)	82 (2083)	31 (787)	48 (1219)	50 (1270)	66 (1676)	28 (711)	16 (406)	32.5 (826)	16 (406)
030	98 (2489)	60 (1524)	32 (813)	36 (914)	38 (965)	54 (1372)	58 (1473)	28 (711)	16 (406)	94 (2388)	31 (787)	64 (1626)	50 (1270)	78 (1981)	28 (711)	16 (406)	32.5 (826)	16 (406)
035	102 (2591)	66 (1676)	36 (914)	40 (1016)	42 (1067)	58 (1473)	62 (1575)	32 (813)	18 (457)	98 (2489)	35.1 (892)	64 (1626)	56 (1422)	82 (2083)	32 (813)	16 (406)	37.9 (963)	18 (457)
045	106 (2692)	78 (1981)	42 (1067)	46 (1168)	48 (1219)	64 (1626)	68 (1727)	40 (1016)	20 (508)	102 (2591)	28.7 (729)	64 (1626)	68 (1727)	86 (2184)	38 (965)	20 (508)	22.9 (582)	20 (508)
055	106 (2692)	90 (2286)	48 (1219)	52 (1321)	54 (1372)	70 (1778)	74 (1880)	48 (1219)	22 (559)	102 (2591)	34.1 (866)	64 (1626)	80 (2032)	86 (2184)	44 (1118)	22 (559)	27 (686)	24 (610)
065	136 (3454)	92 (2337)	46 (1168)	50 (1270)	52 (1321)	68 (1727)	72 (1829)	42 (1067)	26 (660)	132 (3353)	—	—	—	132 (3353)	42 (1067)	24 (610)	25.6 (650)	26 (660)
080	136 (3454)	98 (2489)	50 (1270)	54 (1372)	56 (1422)	72 (1829)	76 (1930)	46 (1168)	26 (660)	132 (3353)	—	—	—	132 (3353)	46 (1168)	26 (660)	28.3 (719)	26 (660)
085	136 (3454)	104 (2642)	54 (1372)	58 (1473)	60 (1524)	76 (1930)	80 (2032)	50 (1270)	27 (686)	132 (3353)	—	—	—	132 (3353)	50 (1270)	26 (660)	31 (787)	28 (711)
090	136 (3454)	110 (2794)	56 (1422)	60 (1524)	62 (1575)	72 (1829)	82 (2083)	52 (1321)	29 (737)	132 (3353)	—	—	—	132 (3353)	52 (1321)	28 (711)	32.4 (823)	30 (762)

* These are the dimensions of the unit only. Curb-ready base adds 6" (152 mm) to the unit height.

** A standard base rail adds 8" (203 mm) to the width and adds between 4" to 12" (102 mm to 305 mm) to the unit height. Height dimension does not include 2" roof cap seam.

Diffuser

Figure 40: Dimensional Data—Diffuser

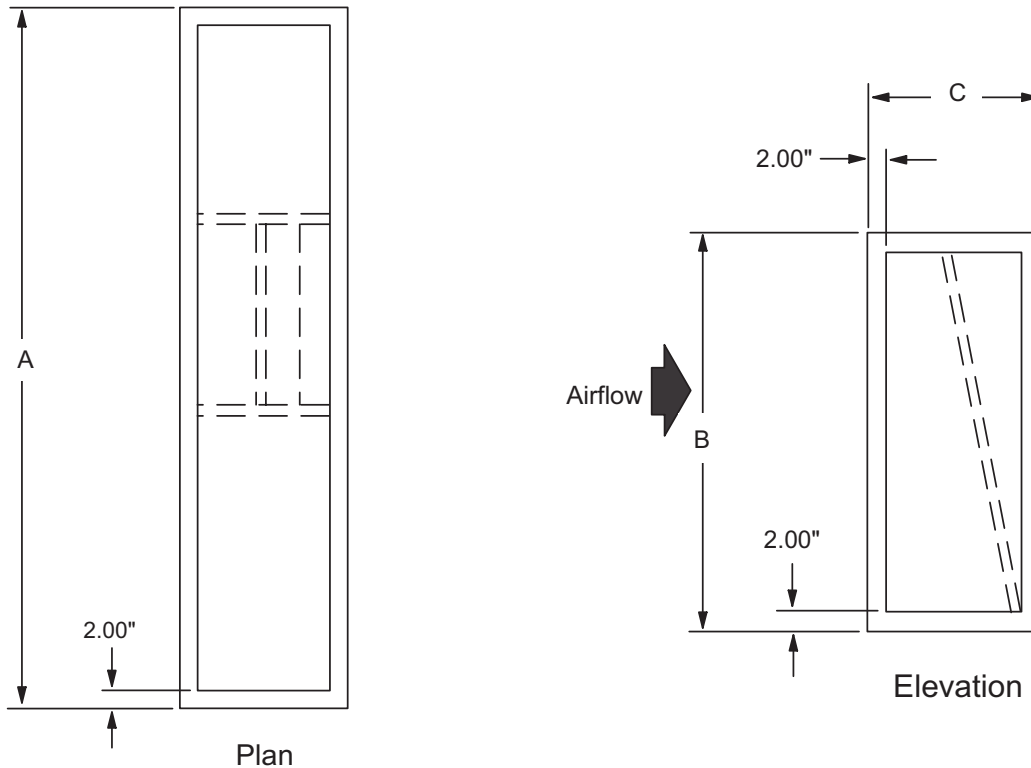

Table 44: Dimensions—Diffuser

Unit Size	A*	B*	C	
			Housed Fans	Inline Fans
	in. (mm)	in. (mm)	in. (mm)	in. (mm)
003	38 (965)	26 (660)	10 (254)	N/A
004	40 (1016)	30 (762)	10 (254)	N/A
006	52 (1321)	30 (762)	10 (254)	N/A
008	58 (1473)	34 (864)	12 (305)	N/A
010	64 (1626)	36 (914)	12 (305)	18 (457)
012	66 (1676)	42 (1067)	16 (406)	18 (457)
014	74 (1880)	42 (1067)	16 (406)	18 (457)
017	80 (2032)	46 (1168)	16 (406)	22 (559)
021	82 (2083)	52 (1321)	16 (406)	26 (660)
025	86 (2184)	60 (1524)	24 (610)	26 (660)
030	98 (2489)	60 (1524)	24 (610)	26 (660)
035	102 (2591)	66 (1676)	24 (610)	28 (711)
045	106 (2692)	78 (1981)	30 (762)	30 (762)
055	106 (2692)	90 (2286)	30 (762)	30 (762)
065	136 (3454)	92 (2337)	30 (762)	38 (965)
080	136 (3454)	98 (3489)	30 (762)	38 (965)
085	136 (3454)	104 (2642)	30 (762)	38 (965)
090	136 (3454)	110 (2794)	30 (762)	38 (965)

* These are the dimensions of the unit only. Curb-ready base adds 6" (152 mm) to the unit height. A standard base rail adds 8" (203 mm) to the width, and between 4" to 12" (102 mm to 305 mm) to the unit height. A 6" (152 mm) base rail is mandatory on unit sizes 025 to 065. An 8" (203 mm) base rail is mandatory on all sizes 080 and larger. Height dimension does not include 2" roof cap seam.

Economizer Section

Figure 41: Dimensional Data—Economizer Section

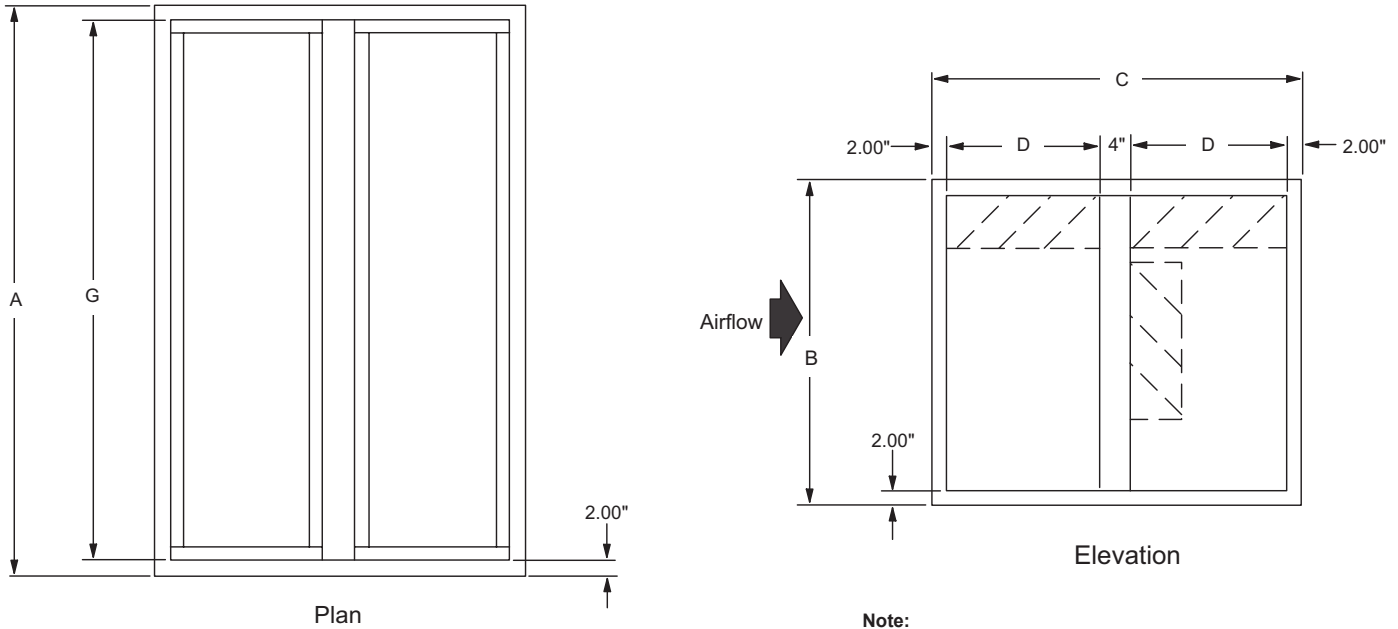

Note:
Dampers can be located in the top, bottom, drive side and opposite drive side, and end of the section. Top and bottom fresh air dampers are not available if hoods are selected.

Table 45: Dimensions—Economizer

Unit Size	A*	B*	C				D	G	Damper Width	Damper Length	
			Econ. Only	w/ 2" Flat Filter	w/ 4" Flat Filter	w/ 2" Angle Filter					w/ 4" Angle Filter
			in. (mm)	in. (mm)	in. (mm)	in. (mm)					in. (mm)
003	38 (965)	28 (711)	40 (1016)	44 (1118)	46 (1168)	62 (1575)	N/A	16 (406)	34 (864)	12 (305)	24 (610)
004	40 (1016)	32 (813)	40 (1016)	44 (1118)	46 (1168)	62 (1575)	N/A	16 (406)	36 (914)	12 (305)	26 (660)
006	52 (1321)	32 (813)	40 (1016)	44 (1118)	46 (1168)	62 (1575)	N/A	16 (406)	48 (1219)	12 (305)	38 (965)
008	58 (1473)	34 (864)	40 (1016)	44 (1118)	46 (1168)	62 (1575)	66 (1676)	16 (406)	54 (1372)	12 (305)	44 (1118)
010	64 (1626)	38 (965)	44 (1118)	48 (1219)	50 (1270)	66 (1676)	70 (1778)	18 (457)	60 (1524)	14 (356)	50 (1270)
012	66 (1676)	44 (1118)	48 (1219)	52 (1321)	54 (1372)	70 (1778)	74 (1880)	20 (508)	62 (1575)	16 (406)	52 (1321)
014	74 (1880)	44 (1118)	48 (1219)	52 (1321)	54 (1372)	70 (1778)	74 (1880)	20 (508)	70 (1778)	16 (406)	60 (1524)
017	80 (2032)	46 (1168)	52 (1321)	56 (1422)	58 (1473)	74 (1880)	78 (1981)	22 (559)	76 (1930)	18 (457)	66 (1676)
021	82 (2083)	52 (1321)	60 (1524)	64 (1626)	66 (1676)	82 (2083)	86 (2184)	26 (660)	78 (1981)	22 (559)	68 (1727)
025	86 (2184)	60 (1524)	64 (1626)	68 (1727)	70 (1778)	86 (2184)	90 (2286)	28 (711)	82 (2083)	24 (610)	72 (1829)
030	98 (2489)	60 (1524)	64 (1626)	68 (1727)	70 (1778)	86 (2184)	90 (2286)	28 (711)	94 (2388)	24 (610)	84 (2134)
035	102 (2591)	66 (1676)	72 (1829)	76 (1930)	78 (1981)	94 (2388)	98 (2489)	32 (813)	98 (2489)	28 (711)	88 (2235)
040	116 (2946)	68 (1727)	72 (1829)	76 (1930)	78 (1981)	94 (2388)	98 (2489)	32 (813)	112 (2845)	28 (711)	102 (2591)
050	120 (3048)	80 (2032)	80 (2032)	84 (2134)	86 (2184)	102 (2591)	106 (2692)	36 (914)	116 (2946)	32 (813)	106 (2692)
065	136 (3454)	92 (2337)	92 (2337)	96 (2438)	98 (2489)	114 (2896)	118 (2997)	42 (1067)	132 (3353)	38 (965)	122 (3099)
080	136 (3454)	98 (3489)	100 (2540)	108 (2743)	112 (2845)	144 (3658)	152 (3861)	46 (1168)	132 (3353)	42 (1067)	122 (3099)
085	136 (3454)	104 (2642)	108 (2743)	116 (2946)	120 (3048)	152 (3861)	160 (4064)	50 (1270)	132 (3353)	46 (1168)	122 (3099)
090	136 (3454)	110 (2794)	112 (2845)	120 (3048)	124 (3150)	156 (3962)	164 (4166)	52 (1321)	132 (3353)	48 (1219)	122 (3099)

* These are the dimensions of the unit only. Curb-ready base adds 6" (152 mm) to the unit height. A standard base rail adds 8" (203 mm) to the width, and between 4" to 12" (102 mm to 305 mm) to the unit height. A base rail—mandatory on unit sizes 025 to 065—adds a minimum of 6" (152 mm) to the unit height. Unit sizes greater than 080 require a base rail that adds a minimum of 8" (203 mm) to the unit height.

Economizer Section, Angled Economizer Section

Figure 42: Dimensional Data—Angled Economizer Section

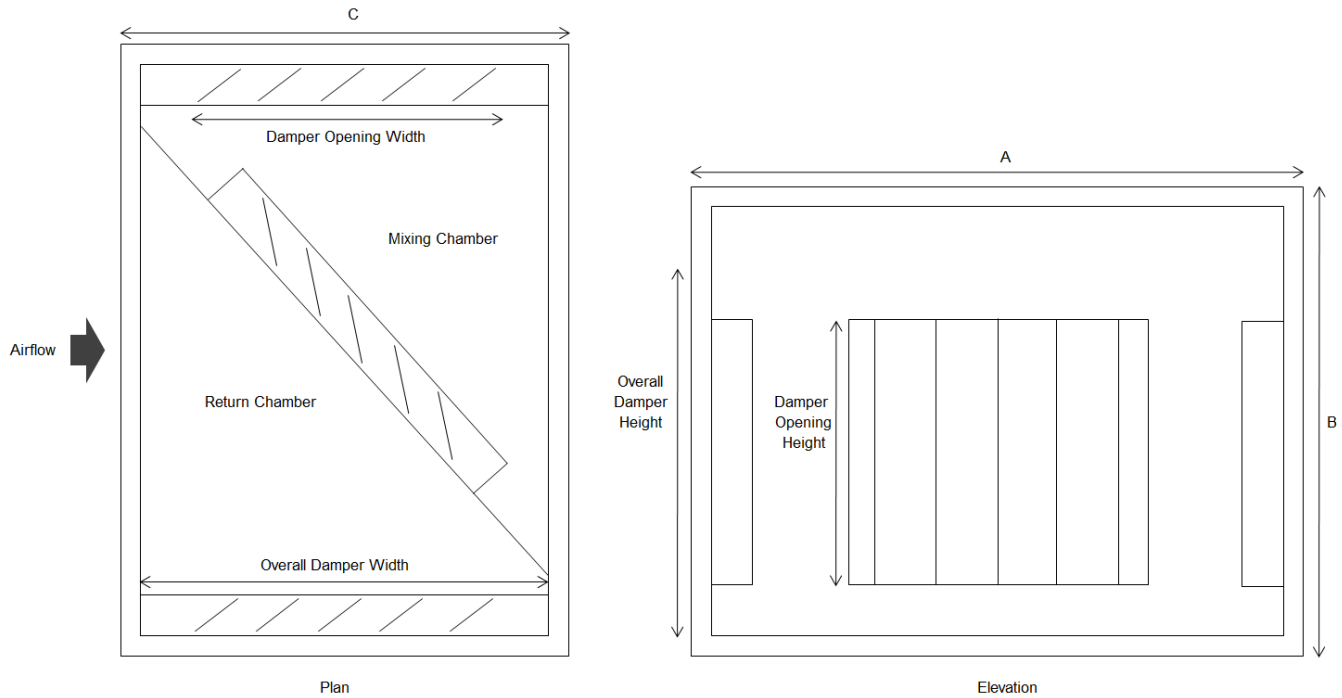

Table 46: Dimensions—Angled Economizer

Unit Size	A*	B*	C	Overall Damper		Damper Opening	
				Width	Height	Width	Height
				in. (mm)	in. (mm)	in. (mm)	in. (mm)
008	58 (1473)	34 (864)	36 (914)	32 (813)	24 (610)	28 (711)	14 (356)
010	64 (1626)	38 (965)	36 (914)	32 (813)	28 (711)	28 (711)	18 (457)
012	66 (1676)	44 (1118)	32 (813)	28 (711)	34 (864)	24 (610)	24 (610)
014	74 (1880)	44 (1118)	36 (914)	32 (813)	34 (864)	28 (711)	24 (610)
017	80 (2032)	46 (1168)	40 (1016)	36 (914)	36 (914)	32 (813)	26 (660)
021	82 (2083)	52 (1321)	40 (1016)	36 (914)	42 (1067)	32 (813)	32 (813)
025	86 (2184)	60 (1524)	38 (965)	34 (864)	50 (1270)	30 (762)	40 (1016)
030	98 (2489)	60 (1524)	44 (1118)	40 (1016)	50 (1270)	36 (914)	40 (1016)
035	102 (2591)	66 (1676)	46 (1168)	42 (1067)	56 (1422)	38 (965)	46 (1168)
045	106 (2692)	78 (1981)	46 (1168)	42 (1067)	68 (1727)	38 (965)	58 (1473)
055	106 (2692)	90 (2286)	46 (1168)	42 (1067)	80 (2032)	38 (965)	70(1778)
065	136 (3454)	92 (2337)	52 (1321)	48 (1219)	82 (2083)	44 (1118)	72 (1829)
080	136 (3454)	98 (2489)	68 (1727)	60 (1524)	88 (2235)	52 (1321)	78 (1981)
085	136 (3454)	104 (2642)	68 (1727)	60 (1524)	94 (2388)	52 (1321)	84 (2134)
090	136 (3454)	110 (2794)	56 (1422)	52 (1321)	100 (2540)	48 (1219)	90 (2286)

* These are the dimensions of the unit only. Curb-ready base adds 6" (152 mm) to the unit height. A standard base rail adds 8" (203 mm) to the width, and between 4" to 12" (102 mm to 305 mm) to the unit height. A base rail—mandatory on unit sizes 025 to 065—adds a minimum of 6" (152 mm) to the unit height. Unit sizes greater than 080 require a base rail that adds a minimum of 8" (203 mm) to the unit height.

Economizer Section, Side Dampers/Hoods

Figure 43: Dimensional Data—Economizer Section, Side Dampers/Hoods

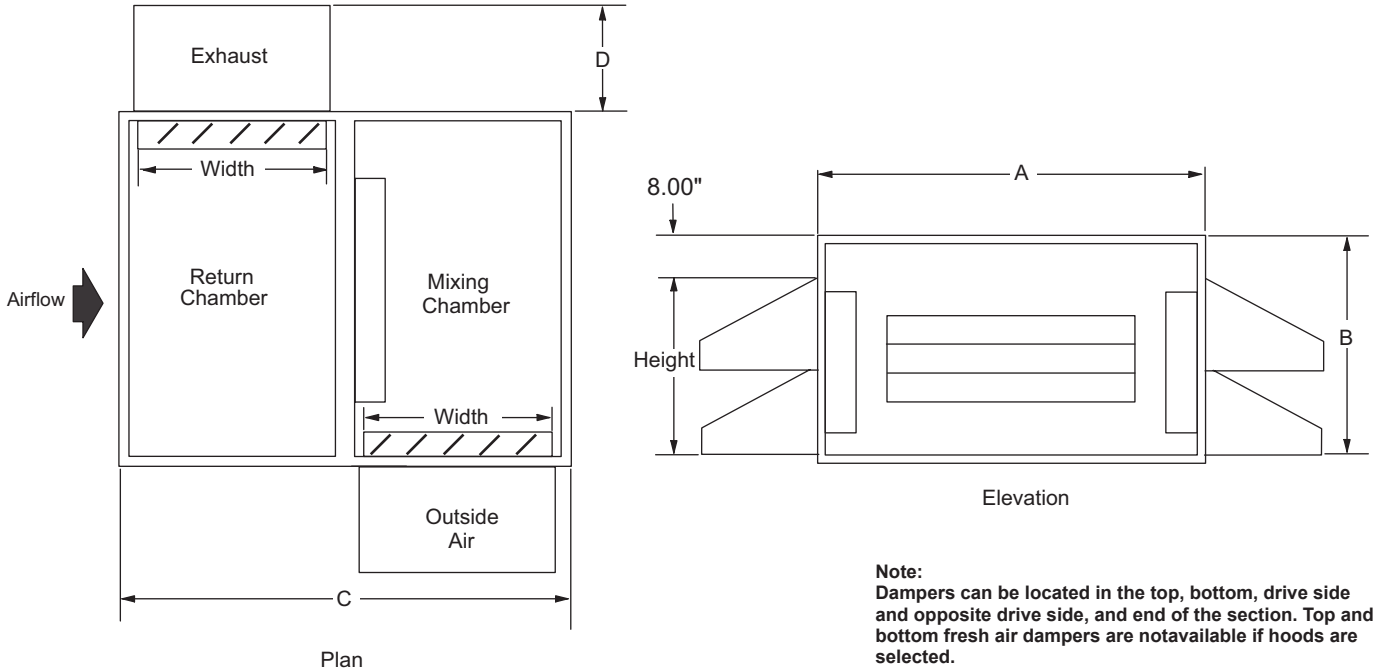

Table 47: Dimensions—Economizer Section, Side Dampers with Hoods

Unit Size	A*	B*	C	D	Exhaust Air Damper		Fresh Air Damper	
					Width	Height	Width	Height
					in. (mm)	in. (mm)	in. (mm)	in. (mm)
003	38 (965)	28 (711)	52 (1321)	19 (483)	22 (559)	18 (457)	22 (559)	18 (457)
004	40 (1016)	32 (813)	52 (1321)	24.4 (620)	22 (559)	22 (559)	22 (559)	22 (559)
006	52 (1321)	32 (813)	60 (1524)	24.4 (620)	26 (660)	22 (559)	26 (660)	22 (559)
008	58 (1473)	34 (864)	100 (2540)	27.1 (688)	46 (1168)	24 (610)	46 (1168)	24 (610)
010	64 (1626)	38 (965)	96 (2438)	32.5 (826)	44 (1118)	28 (711)	44 (1118)	28 (711)
012	66 (1676)	44 (1118)	88 (2235)	40.6 (1031)	40 (1016)	34 (864)	40 (1016)	34 (864)
014	74 (1880)	44 (1118)	100 (2540)	40.6 (1031)	46 (1168)	34 (864)	46 (1168)	34 (864)
017	80 (2032)	46 (1168)	112 (2845)	21.6 (549)	52 (1321)	36 (914)	52 (1321)	36 (914)
021	82 (2083)	52 (1321)	112 (2845)	25.6 (650)	52 (1321)	42 (1067)	52 (1321)	42 (1067)
025	86 (2184)	60 (1524)	104 (2642)	31 (787)	48 (1219)	50 (1270)	48 (1219)	50 (1270)
030	98 (2489)	60 (1524)	136 (3454)	31 (787)	64 (1626)	50 (1270)	64 (1626)	50 (1270)
035	102 (2591)	66 (1676)	136 (3454)	35.1 (892)	64 (1626)	56 (1422)	64 (1626)	56 (1422)
045	106 (2692)	78 (1981)	136 (3454)	28.7 (729)	64 (1626)	68 (1727)	64 (1626)	68 (1727)
055	106 (2692)	90 (2286)	160 (4064)	28.7 (729)	76 (1930)	68 (1727)	76 (1930)	68 (1727)
065	136 (3454)	92 (2337)	160 (4064)	35 (889)	76 (1930)	—	82 (2083)	—
080	136 (3454)	98 (2489)	160 (4064)	37.7 (958)	76 (1930)	—	88 (2235)	—
085	136 (3454)	104 (2642)	160 (4064)	40.4 (1026)	76 (1930)	—	94 (2388)	—
090	136 (3454)	110 (2794)	176 (4470)	32.3 (820)	84 (2134)	—	100 (2540)	—

* These are the dimensions of the unit only. Curb-ready base adds 6" (152 mm) to the unit height. A standard base rail adds 8" (203 mm) to the width, and between 4" to 12" (102 mm to 305 mm) to the unit height. Height dimension does not include 2" roof cap seam.

Access Doors

Access doors are an option for most sections. Fan sections are always provided with a door on one side of the unit. Access door size varies with the size of the section; they are never wider than 30". Once the door is opened outward, the opening is 2" less than the door height and width because there is a 1"

flange around the opening. Door height is always 4" shorter than section height unless the section has a drain connection. If the section has a drain pan, then the door is 6" shorter than the section height. The maximum door height is 64", except filter section doors, which are equal to section height minus 4".

Figure 44: Dimensional Data—Access Doors

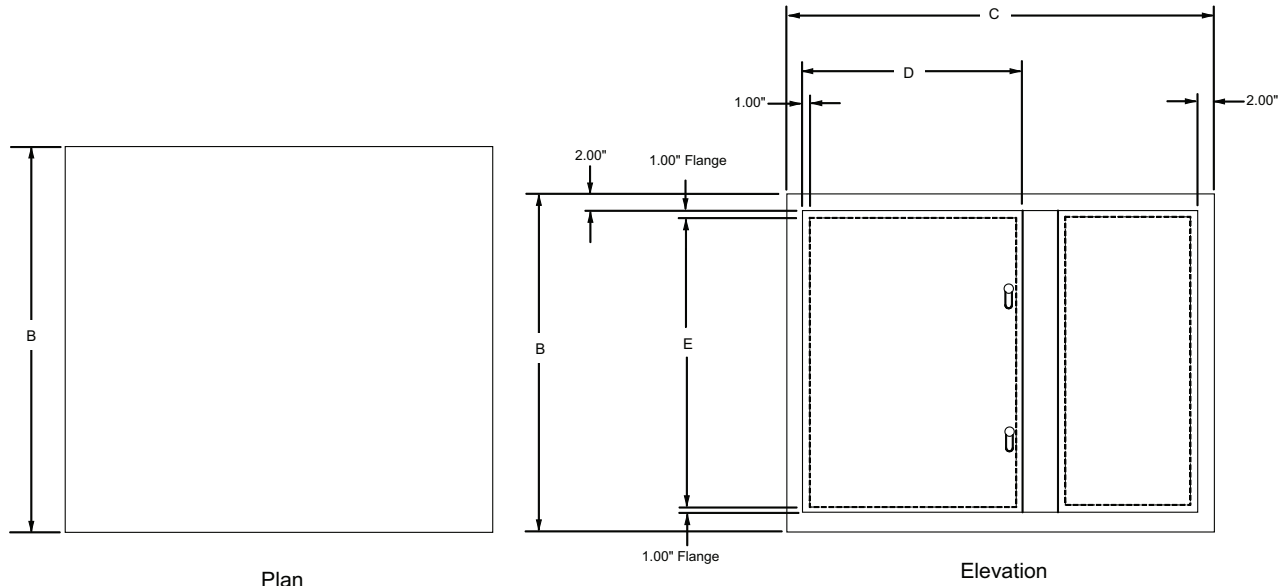

Table 48: Dimensions—Access Door

Unit Size	Unit Cross Section	
	A*	B*
	in. (mm)	in. (mm)
003	38 (965)	26 (660)
004	40 (1016)	30 (762)
006	52 (1321)	30 (762)
008	58 (1473)	34 (864)
010	64 (1626)	36 (914)
012	66 (1676)	42 (1067)
014	74 (1880)	42 (1067)
017	80 (2032)	46 (1168)
021	82 (2083)	52 (1321)
025	86 (2184)	60 (1524)
030	98 (2489)	60 (1524)
035	102 (2591)	66 (1676)
045	106 (2692)	78 (1981)
055	106 (2692)	90 (2286)
065	136 (3454)	92 (2337)
080	136 (3454)	98 (3489)
085	136 (3454)	104 (2642)
090	136 (3454)	110 (2794)

* Dimensions of the unit only. A standard base rail adds 8" (203 mm) to width and between 4" to 12" (102 mm to 305 mm) to unit height. A 6" (152mm) base rail is mandatory on unit sizes 025 to 065. An 8" (203 mm) baserail is mandatory on all sizes 080 and larger. Height dimension does not include 2" roof cap seam.

Table 49: Dimensions—Door Widths

Available Door Widths Based on Section Length	
C	D
in. (mm)	in. (mm)
12 (305)	8 (203)
14 (356)	10 (254)
16 (406)	12 (305)
18 (457)	14 (356)
20 (508)	16 (406)
22 (559)	18 (457)
24 (610)	20 (508)
26 (660)	22 (559)
28 (711)	24 (610)
30 (762)	26 (660)
32 (813)	28 (711)
34 (864)	30 (762)
36 (914)	28 (711)
38 (965)	30 (762)
40 (1016)	30 (762)
42 (1067)	30 (762)
44 (1118)	30 (762)
46 (1168)	30 (762)
48 (1219)	30 (762)
50 (1270)	30 (762)
52 (1321)	30 (762)
54 (1372)	30 (762)

Access Section

Figure 45: Dimensional Data—Access Section

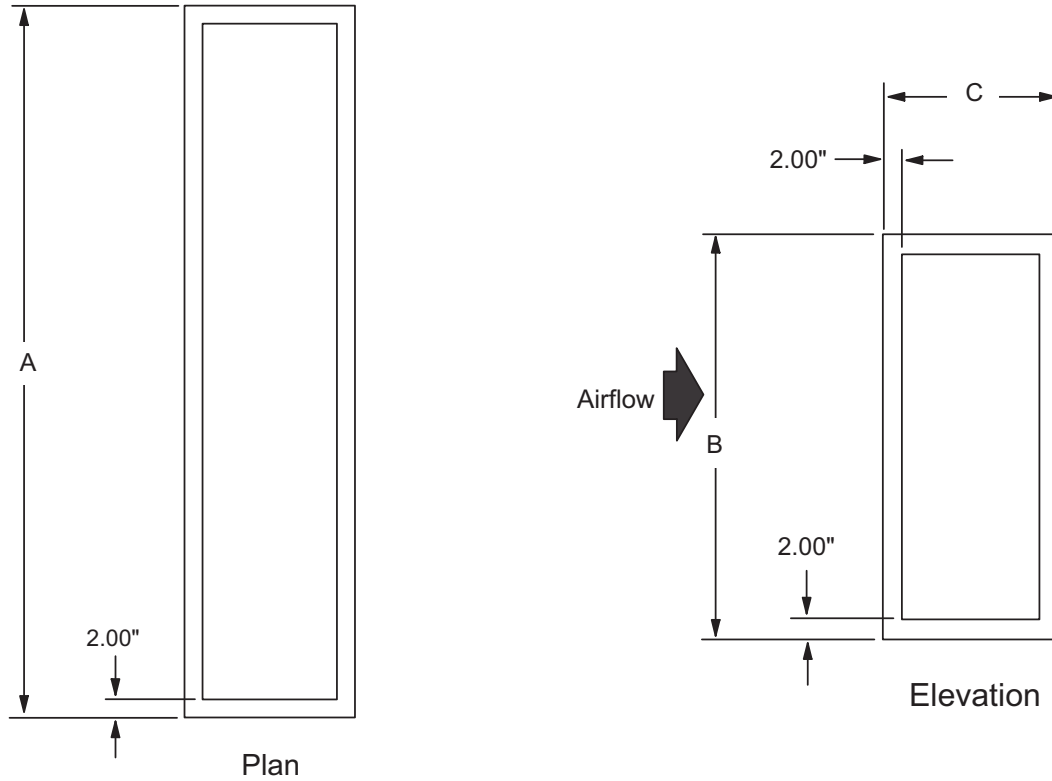

NOTE: Note: 1.25 MPT drain connection available as an option for access sections.

Table 50: Dimensions—Access Section

Unit Size	A*	B*	C** (available all sizes)
	in. (mm)	in. (mm)	in. (mm)
003	38 (965)	26 (660)	16.0 (406.4) to 54.0 (1372) In 2" increments
004	40 (1016)	30 (762)	
006	52 (1321)	30 (762)	
008	58 (1473)	34 (864)	
010	64 (1626)	36 (914)	
012	66 (1676)	42 (1067)	
014	74 (1880)	42 (1067)	
017	80 (2032)	46 (1168)	
021	82 (2083)	52 (1321)	
025	86 (2184)	60 (1524)	
030	98 (2489)	60 (1524)	
035	102 (2591)	66 (1676)	
045	106 (2692)	78 (1981)	
055	106 (2692)	90 (2286)	
065	136 (3454)	92 (2337)	
080	136 (3454)	98 (3489)	
085	136 (3454)	104 (2642)	
090	136 (3454)	110 (2794)	

* These are the dimensions of the unit only. Curb-ready base adds 6" (152 mm) to the unit height. A standard base rail adds 8" (203 mm) to the width, and between 4" to 12" (102 mm to 305 mm) to the unit height. A 6" (152 mm) base rail is mandatory on unit sizes 025 to 065. An 8" (203 mm) base rail is mandatory on all sizes 080 and larger.

** 16.0", 24.0", 30.0", 36.0", 42.0", 48.0" and 54.0" access section lengths available for all unit sizes. Height dimension does not include 2" roof cap seam.

Internal/External Face and Bypass Sections

Figure 46: Dimensional Data—Internal/External Face and Bypass Sections

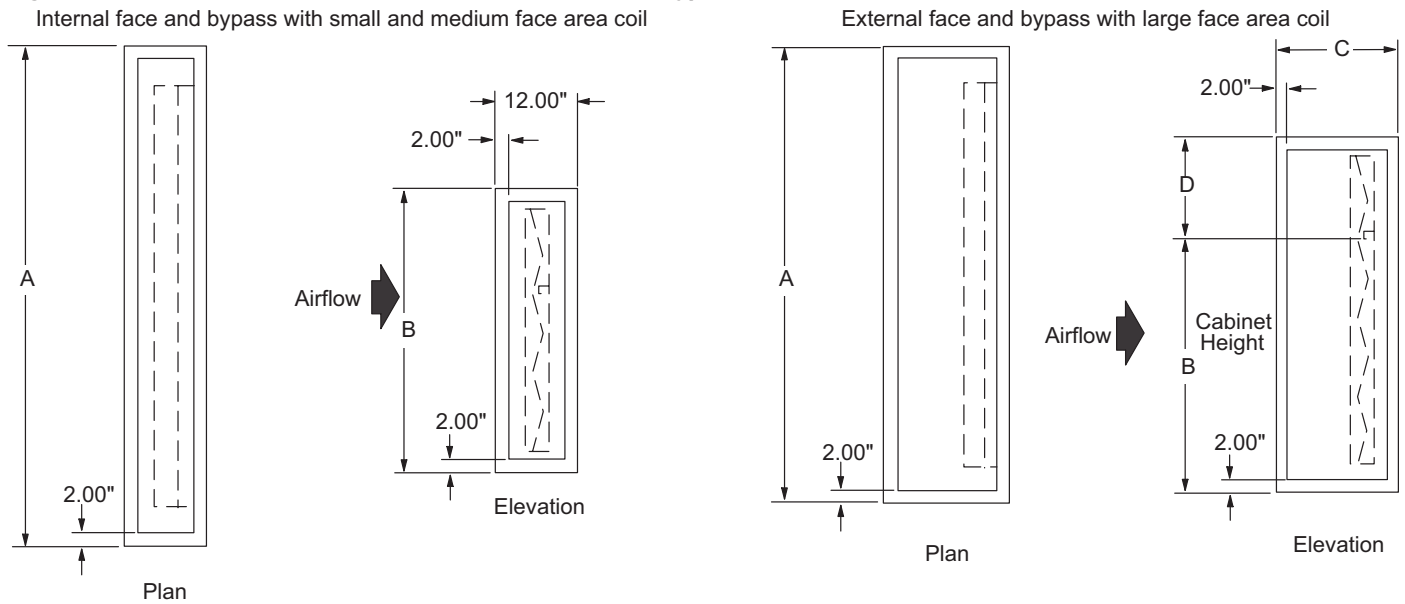

Table 51: Dimensions—Internal and External Faced and Bypass

Unit Size	A*	B*	C – Internal	C – External	D
	in. (mm)	in. (mm)	in. (mm)	in. (mm)	in. (mm)
003	38 (965)	26 (660)	12 (305)	18 (457)	10 (254)
004	40 (1016)	30 (762)	12 (305)	18 (457)	10 (254)
006	52 (1321)	30 (762)	12 (305)	18 (457)	10 (254)
008	58 (1473)	34 (864)	12 (305)	20 (508)	10 (254)
010	64 (1626)	36 (914)	12 (305)	22 (559)	12 (305)
012	66 (1676)	42 (1067)	12 (305)	24 (610)	16 (406)
014	74 (1880)	42 (1067)	12 (305)	24 (610)	16 (406)
017	80 (2032)	46 (1168)	12 (305)	26 (660)	16 (406)
021	82 (2083)	52 (1321)	12 (305)	30 (762)	22 (559)
025	86 (2184)	60 (1524)	12 (305)	32 (813)	24 (610)
030	98 (2489)	60 (1524)	12 (305)	32 (813)	24 (610)
035	102 (2591)	66 (1676)	12 (305)	34 (864)	26 (660)
045	106 (2692)	78 (1981)	12 (305)	44 (1118)	30 (762)
055	106 (2692)	90 (2286)	12 (305)	50 (1270)	36 (914)
065**	136 (3454)	92 (2337)	12 (305)	50 (1270)	36 (914)
080**	136 (3454)	98 (3489)	12 (305)	54 (1372)	38 (965)
085**	136 (3454)	104 (2642)	12 (305)	56 (1422)	42 (1067)
090**	136 (3454)	110 (2794)	12 (305)	58 (1473)	44 (1118)

* These are the dimensions of the unit only. Curb-ready base adds 6" (152 mm) to the unit height. A standard base rail adds 8" (203 mm) to the width, and between 4" to 12" (102 mm to 305 mm) to the unit height. A 6" (152 mm) base rail is mandatory on unit sizes 025-065. An 8" (203 mm) base rail is mandatory on all sizes 080 and larger.

** Right angle face and bypass dampers are mandatory on unit sizes 040 and larger. Height dimension does not include 2" roof cap seam.

Discharge or Return Plenum

Return and discharge plenums are available with openings in the top, bottom, upper end, lower end, drive side, or opposite drive side. The opening size does not vary with the location. All openings have a 1" flange recessed in opening. 1.25 MPT drain connection available as an option for plenum sections.

Figure 47: Dimensional Data—Discharge or Return Plenum

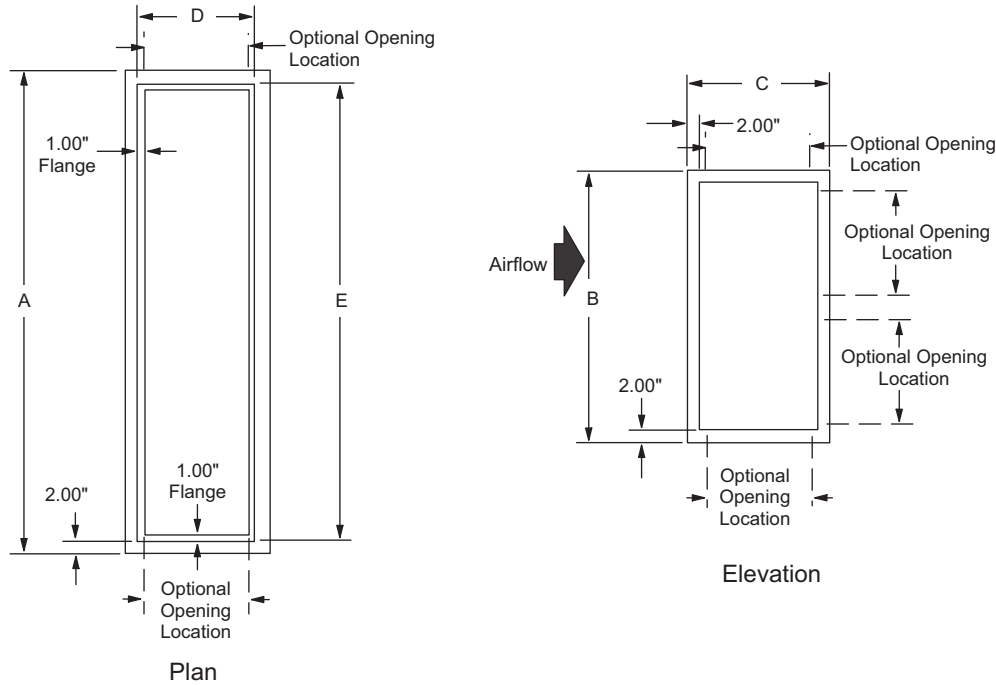

Table 52: Dimensions—Discharge or Return Plenum

Unit Size	A*	B*	C	D	E
	in. (mm)	in. (mm)	in. (mm)	in. (mm)	in. (mm)
003	38 (965)	26 (660)	14 (356)	10 (254)	34 (864)
004	40 (1016)	30 (762)	16 (406)	12 (305)	36 (914)
006	52 (1321)	30 (762)	16 (406)	12 (305)	48 (1219)
008	58 (1473)	34 (864)	18 (457)	14 (356)	54 (1372)
010	64 (1626)	36 (914)	20 (508)	16 (406)	60 (1524)
012	66 (1676)	42 (1067)	22 (559)	18 (457)	62 (1575)
014	74 (1880)	42 (1067)	22 (559)	18 (457)	70 (1778)
017	80 (2032)	46 (1168)	24 (610)	20 (508)	76 (1930)
021	82 (2083)	52 (1321)	28 (711)	24 (610)	78 (1981)
025	86 (2184)	60 (1524)	30 (762)	26 (660)	82 (2083)
030	98 (2489)	60 (1524)	30 (762)	26 (660)	94 (2388)
035	102 (2591)	66 (1676)	32 (813)	28 (711)	98 (2489)
045	106 (2692)	78 (1981)	36 (914)	32 (813)	102 (2591)
055	106 (2692)	90 (2286)	44 (1016)	40 (1016)	102 (2591)
065	136 (3454)	92 (2337)	42 (1067)	38 (965)	132 (3353)
080	136 (3454)	98 (3489)	42 (1067)	44 (1118)	132 (3353)
085	136 (3454)	104 (2642)	44 (1118)	48 (1219)	132 (3353)
090	136 (3454)	110 (2794)	46 (1168)	50 (1270)	132 (3353)

* These are the dimensions of the unit only. Curb-ready base adds 6" (152 mm) to the unit height. A standard base rail adds 8" (203 mm) to the width, and between 4" to 12" (102 mm to 305 mm) to the unit height. A 6" (152 mm) base rail is mandatory on unit sizes 025 to 065. An 8" (203 mm) base rail is mandatory on all sizes 080 and larger. Height dimension does not include 2" roof cap seam.

Sound Attenuator Section

Figure 48: Dimensional Data—Sound Attenuator Section

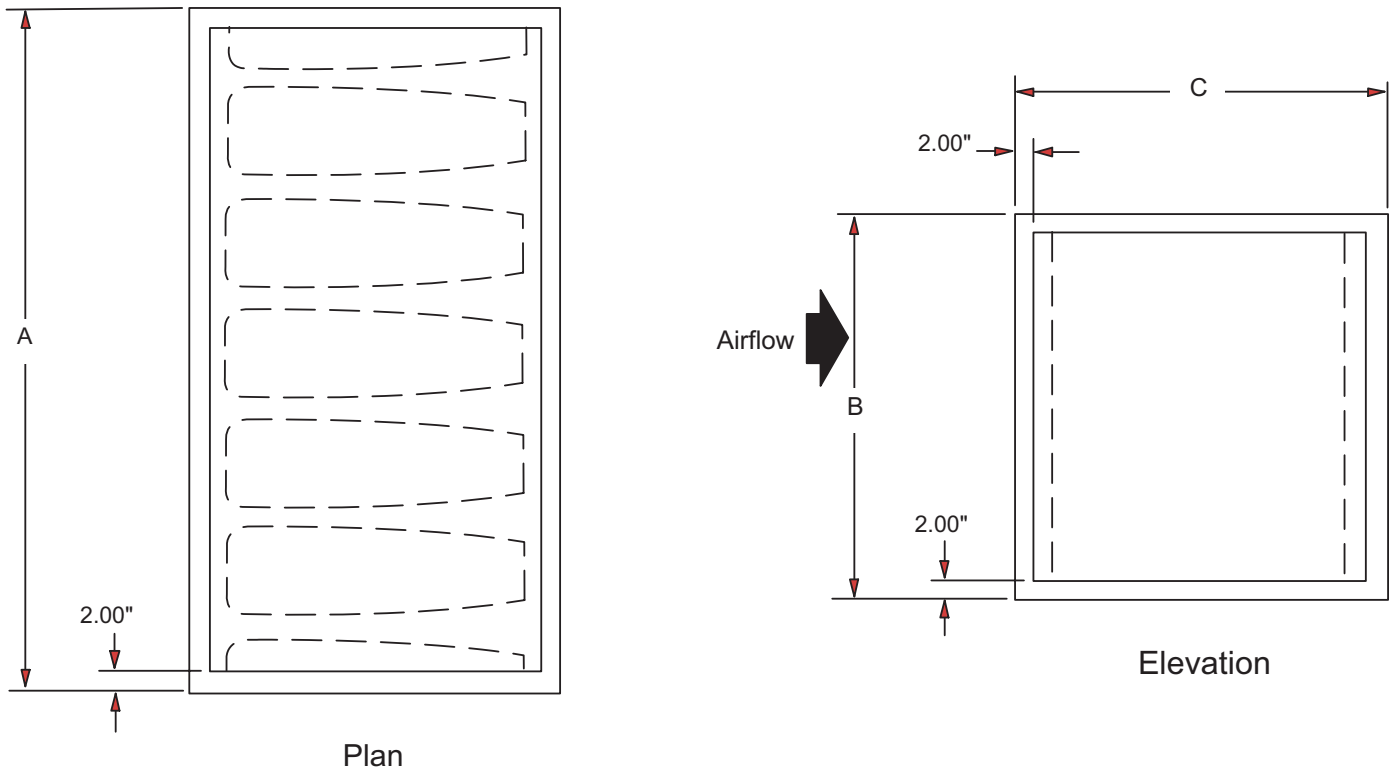

Table 53: Dimensions—Sound Attenuator

Unit Size	A*	B*	C** (Available All Sizes)
	in. (mm)	in. (mm)	in. (mm)
003	38 (965)	26 (660)	—
004	40 (1016)	30 (762)	40 (1016)
006	52 (1321)	30 (762)	52 (1321)
008	58 (1473)	34 (864)	64 (1626)
010	64 (1626)	36 (914)	—
012	66 (1676)	42 (1067)	—
014	74 (1880)	42 (1067)	—
017	80 (2032)	46 (1168)	—
021	82 (2083)	52 (1321)	—
025	86 (2184)	60 (1524)	—
030	98 (2489)	60 (1524)	—
035	102 (2591)	66 (1676)	—
045	106 (2692)	78 (1981)	—
055	106 (2692)	90 (2286)	—
065	136 (3454)	92 (2337)	—
080	136 (3454)	98 (3489)	—
085	136 (3454)	104 (2642)	—
090	136 (3454)	110 (2794)	—

* These are the dimensions of the unit only. Curb-ready base adds 6" (152 mm) to the unit height. A standard base rail adds 8" (203 mm) to the width, and between 4" to 12" (102 mm to 305 mm) to the unit height. A 6" (152 mm) base rail is mandatory on unit sizes 025 to 065. An 8" (203 mm) base rail is mandatory on all sizes 080 and larger.

** 40.0", 52.0" and 64.0" actuator section lengths available for all unit sizes. Height dimension does not include 2" roof cap seam.

Roof Curb and Base Rail

Figure 49: Dimensional Data—Roof Curb

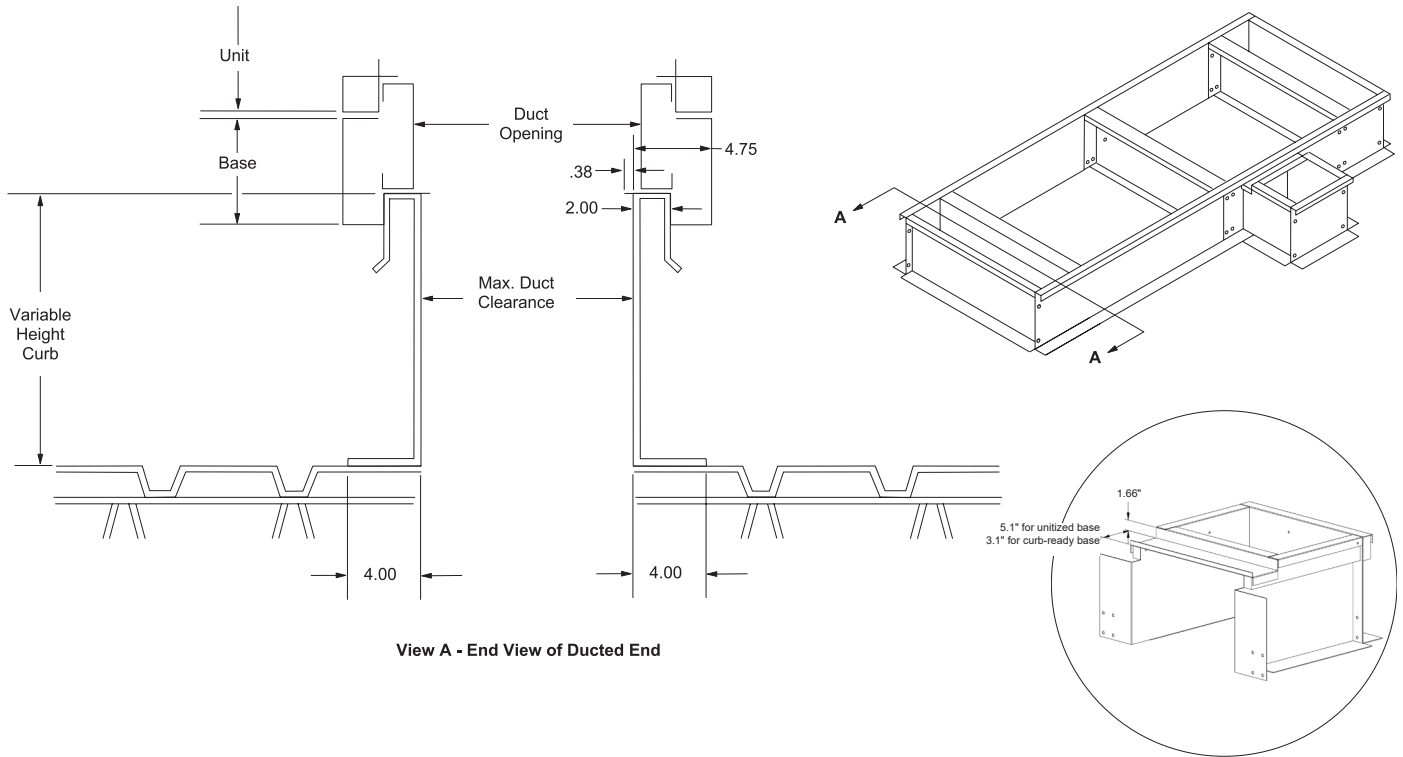
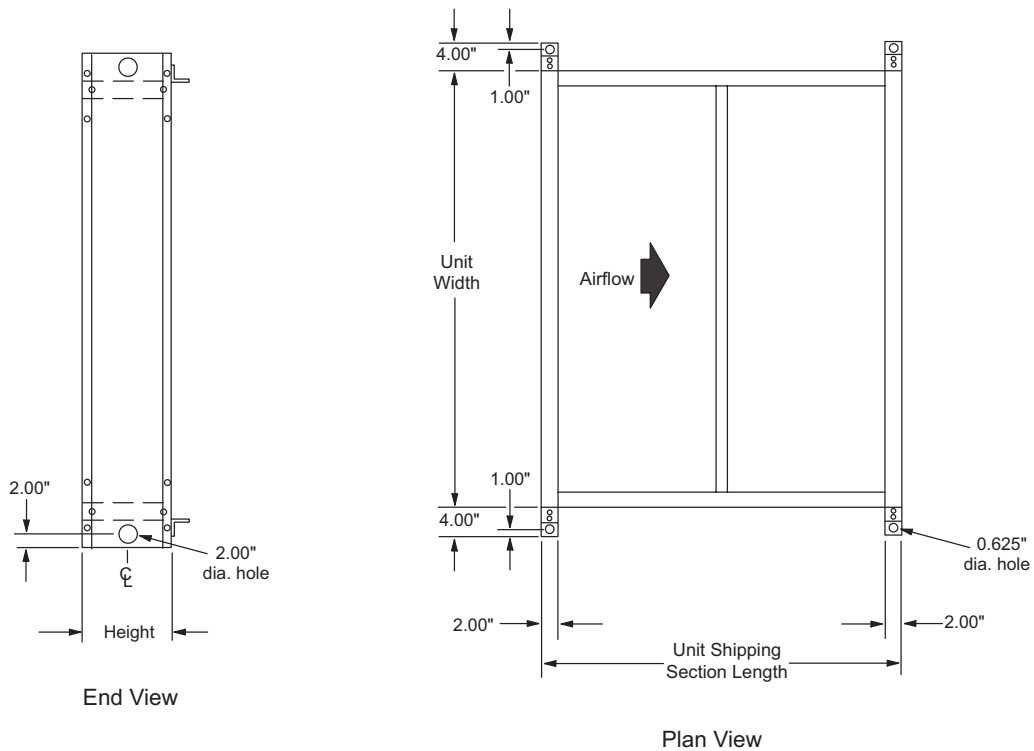
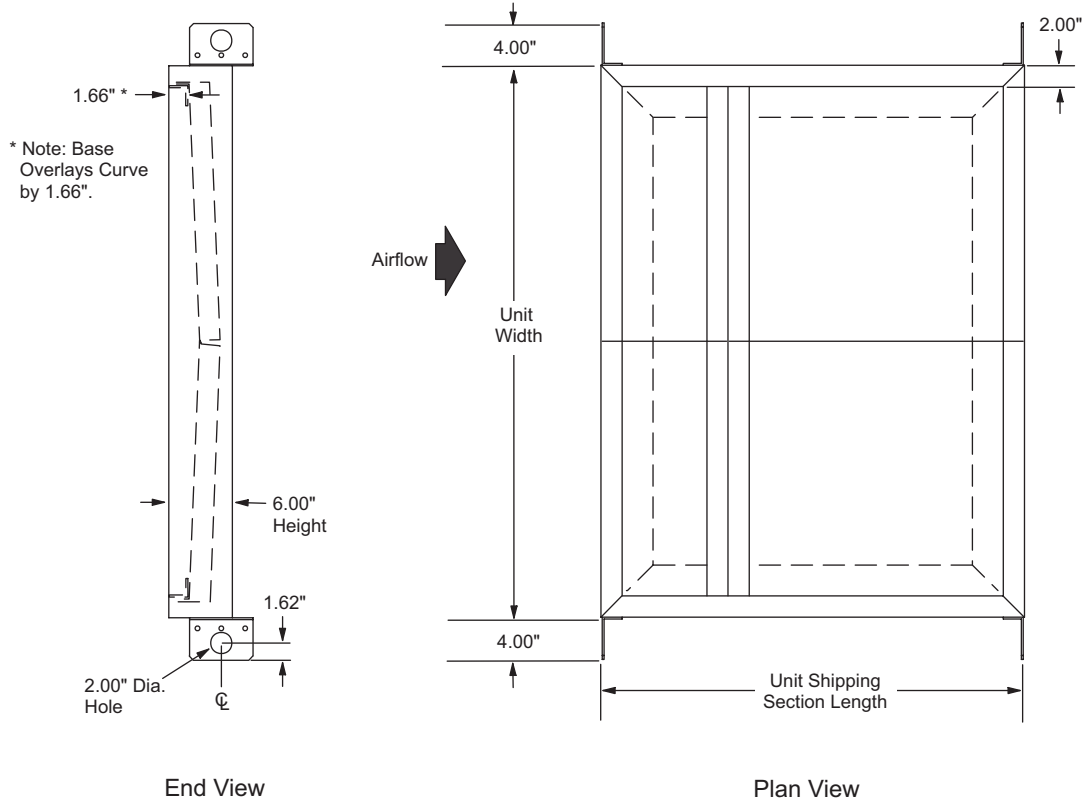

Figure 50: Dimensional Data—Base Rail



NOTE: The base rail is available in heights of 4", 6", 8", 10", and 12".

Figure 51: Dimensional Data—Curb-Ready Base Rail



NOTE: The curb ready base rail is available in 6" height.

Figure 52: Dimensional Data—Unitized Base Rail

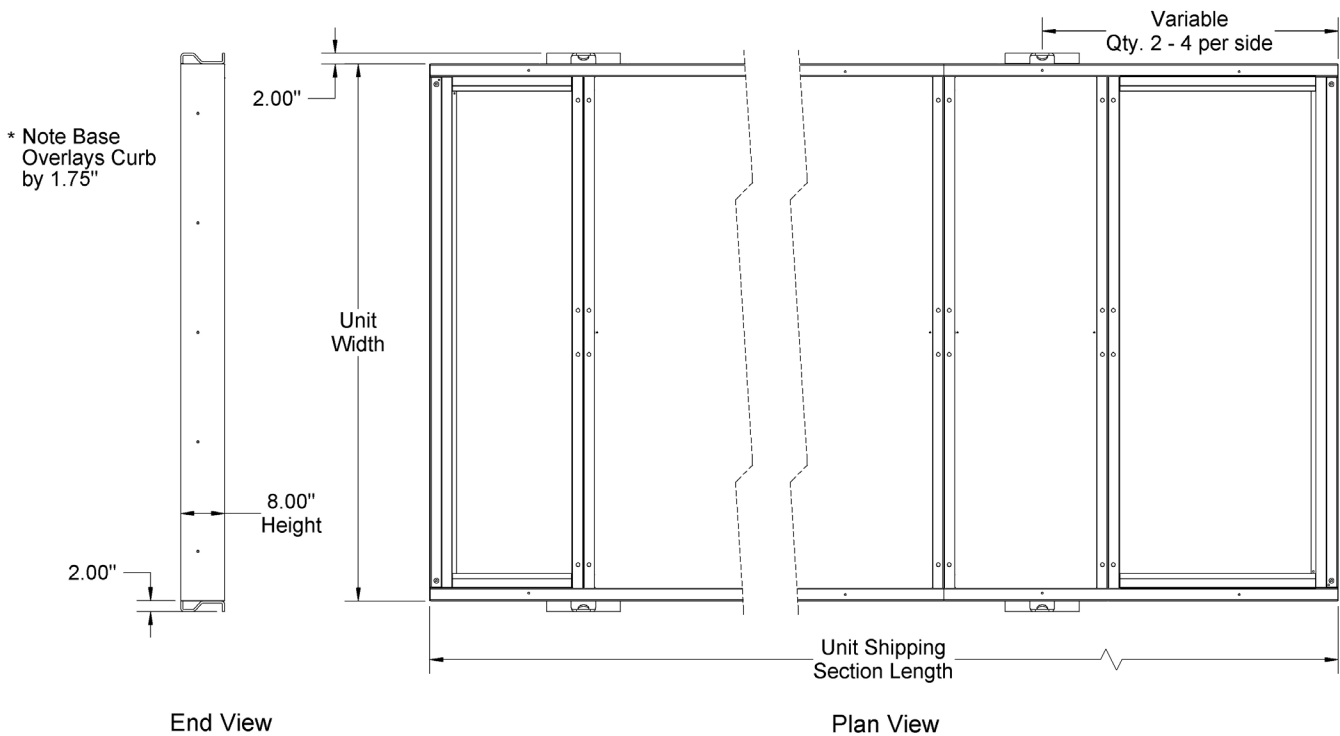

Supply Power Wiring

1. Units required three phase power supply.
2. Allowable voltage tolerances:
 - a. 60 Hertz
 Nameplate 208 V: Min. 187 V, max. 229 V
 Nameplate 230 V: Min. 207 V, max. 253 V
 Nameplate 460 V: Min. 414 V, max. 506 V
 Nameplate 575 V: Min. 518 V, max. 633 V

3. Minimum Circuit Ampacity (MCA) calculation:

If a unit is provided with multiple power connections, each must be considered alone in selecting power wiring components.

For units with cooling and heating:

$$MCA = 1.25 \times \text{largest load} + \text{sum of all other loads}$$

- NOTE:** Control circuit ampacity does not need to be considered in the calculation for wire sizing ampacity. If the unit is provided with one or more fan section lights, they are powered from the separate 15 amp (minimum), 120 V supply required by the NEC for the unit convenience outlet.
4. Size wires in accordance with Table 310-16 or 310-19 of the National Electrical Code.
 5. Wires should be sized for a maximum of 3% voltage drop.

Table 54: Recommended Power Wiring

Ampacity	No. of Power Wires Per Phase	Wire Gauge	Insulation Rating (0°C)
30	1	10	75
40	1	8	75
55	1	6	75
70	1	4	75
85	1	3	75
95	1	2	75
130	1	1	75
150	1	1/0	75
175	1	2/0	75
200	1	3/0	75
230	1	4/0	75
255	1	250	75
300	2	1/0	75
350	2	2/0	75
400	2	3/0	75
460	2	4/0	75
510	2	250	75
600	3	3/0	75
690	3	4/0	75
765	3	250	75

PART 1: GENERAL

1.01 SECTION INCLUDES

- A. Outdoor air handling units.

1.02 REFERENCES

- A. AFBMA 9 - Load Ratings and Fatigue Life for Ball Bearings
- B. AMCA 99 - Standards Handbook
- C. AMCA 210 - Laboratory Methods of Testing Fans for Rating Purposes
- D. AMCA 300 - Test Code for Sound Rating Air Moving Devices
- E. AMCA 500 - Test Methods for Louver, Dampers, and Shutters
- F. AHRI 410 - Forced-Circulation Air-Cooling and Air-Heating Coils
- G. AHRI 430 - Central-Station Air-Handling Units.
- H. AHRI 435 - Application of Central-Station Air-Handling Units
- I. ASTM B117 – Standard Practice for Operating Salt Spray Apparatus
- J. NEMA MG1 - Motors and Generators.
- K. NFPA 70 - National Electrical Code.
- L. SMACNA - HVAC Duct Construction Standards - Metal and Flexible.
- M. UL 723 – Test for Surface Burning Characteristics of Building Materials
- N. UL 900 - Test Performance of Air Filter Units.
- O. UL 1995 – Standard for Heating and Cooling Equipment
- P. UL 94 – Test for Flammability of Plastic Materials for Parts in Devices and Appliances
- Q. IBC 2000, 2003 – International Building Code
- R. NFPA 90A – Standard for the Installation of Air Conditioning and Ventilating Systems
- S. NFPA 5000 – Building Construction and Safety Code
- T. ASHRAE 90.1 Energy Code
- U. AHRI Standard 1060 – Rating Air-to-Air Heat Exchangers for Energy Recovery Ventilation Equipment
- V. GSA 2003 Facilities Standard - 5.9 HVAC Systems and Components

1.03 SUBMITTALS

- A. Shop Drawings: Indicate assembly, unit dimensions, weight loading, required clearances, construction details, field connection details, and electrical characteristics and connection requirements. Computer generated fan curves for each air handling unit shall be submitted with specific design operating point noted. A computer generated psychometric chart shall be submitted for each cooling coil with design points and final operating point clearly noted. Sound data for discharge, radiated and return positions shall be submitted by octave band for each unit. Calculations for required baserail heights to satisfy condensate trapping requirements of cooling coil shall be included.
- B. Product Data:
 1. Provide literature that indicates dimensions, weights, capacities, ratings, fan performance, and electrical characteristics and connection requirements.
 2. Provide data of filter media, filter performance data, filter assembly, and filter frames.
- C. Manufacturer's Installation Instructions.

1.04 QUALIFICATIONS

- A. Manufacturers specializing in manufacturing Air Handling Units specified in this section must prove minimum five years documented experience and issue a complete catalog on total product.

1.05 SAFETY AGENCY LISTED & CERTIFICATION

- A. Air handling units shall be cETLus safety listed that conforms to UL Standard 1995 and CAN/CSA Standard C22.2 No. 236. Units shall be accepted for use in New York City by the Department of Building, MEA 342-99-E.
- B. Air handler furnished with double width, double inlet (DWDI) and/or plenum fans shall be certified in accordance with the central station air handling units certification program, which is based on AHRI 430. (NOTE: Above does not apply to fan array)
- C. Air handling unit water heating & cooling coils shall be certified in accordance with the forced circulation air cooling and air heating coils certification program, which is based on AHRI Standard 410.

1.06 DELIVERY, STORAGE, AND HANDLING

- A. Deliver, store, protect and handle products to site.
- B. Accept products on site in factory-fabricated protective containers, with factory-installed shipping skids. Inspect for damage.
- C. Store in clean dry place and protect from weather and construction traffic. Handle carefully to avoid damage to components, enclosures, and finish.

PART 2: PRODUCTS

2.01 MANUFACTURERS

- A. The following manufacturers are approved for use. No substitutions will be permitted.
1. Daikin Applied as basis of design
 2. Miller-Picking
 3. Temtrol
 4. Scott-Springfield
 5. Racan-Carrier Company

2.02 GENERAL DESCRIPTION

- A. Configuration: Fabricate as detailed on drawings.
- B. Performance: Conform to AHRI 430. See schedules on prints. (NOTE: Above does not apply to fan array)
- C. Acoustics: Sound power levels (dB) for the unit shall not exceed the following specified levels. The manufacturer shall provide the necessary sound treatment to meet these levels if required.

Octave Band at Center Frequency (Hz)								
	63	125	250	500	1000	2000	4000	8000
Radiated								
Discharge								
Return								

- D. [IBC Certification]
1. All components included herein are designed, manufactured and independently tested, rated and certified to meet the seismic compliance standards of the International Building Code. Components designated for use in systems that are life safety, toxic, high hazard, combustible or flammable shall meet the on line, anchorage and load path requirements for life safety as defined in IBC sections 1621.1.6, 1621.3.3, 1707.7.2, and IBC Commentary, Volume II, section 1621.1.6, IBC notes pertaining to the release of hazardous material. All components used as part of a system other than the above shall meet as a minimum, all load path and anchorage standards for components as outlined in IBC section 1621.3.3 & 1707.7.2.
 2. Certification is good for [Fp/Wp = 2.89 gs and Sds = 1.29 gs obtained from a "maximum considered earth quake short period spectral response acceleration Ss of 1.93.] [Fp/Wp = 4.42 gs and Sds = 1.96 gs obtained from a "maximum considered earth quake short period spectral response acceleration Ss of 2.94.]
 3. All completed component assemblies shall be clearly labelled for field inspection. Seismic Compliance Labels shall include the manufacturer's identification, designation of certified models, definitive information describing the product's compliance characteristics, and the Independent Certifying Agency's name and report identification.
 4. In addition to all seismic requirements for IBC

Certification listed elsewhere in the project specification, manufacturer's submittals shall include :

- a. Certificate of Compliance from the Independent Certifying Agency clearly indicating that components supplied on this project are included in the component manufacturer's Certificate of Compliance.
- b. Clear installation instructions including all accessory components that are part of the overall component installation.]

2.03 UNIT CONSTRUCTION

- A. Fabricate unit with 16 gauge channel posts and panels secured with mechanical fasteners. All panels, access doors, and ship sections shall be sealed with permanently applied bulb-type gasket. Shipped loose gasketing is not allowed.
1. Panels and access doors shall be constructed as a 2-inch (50-mm) nominal thick; thermal broke double wall assembly, injected with foam insulation for an R-value of not less than R-13. The outer panel shall be constructed of G60 painted galvanized [18-gauge] steel. The inner liner shall be constructed of G90 galvanized [solid stainless] steel.
 2. Panel deflection shall not exceed L/240 ratio at 125% of design static pressure, maximum positive or negative 8 inches of static pressure. Deflection shall be measured at the midpoint of the panel height.
 3. Panel assembly shall meet UL standard 1995 for fire safety. Panel assembly shall comply with the material requirements of NFPA 90A.
 4. The casing leakage rate shall not exceed [0.50 cfm per square foot of casing surface area at design static pressure up to a maximum of +5" w.c. in positive pressure sections and -6" w.c. in negative pressure sections (.0025 m³/s per square meter of cabinet area at 1.24 kPa static pressure)] [ASHRAE 111 Class 6 at design static pressure up to a maximum of +8" w.c. in positive pressure sections and -8" w.c. (1.99 kPa) in negative pressure sections, where casing leakage (cfm/100 ft² of casing surface area) = C_L × P^{0.65}] [1% of supply air volume at design static pressure up to a maximum of +8" w.c. in positive pressure sections and -8" w.c. (1.99 kPa) in negative pressure sections].
 5. Module to module assembly shall be accomplished with an overlapping, full perimeter, insulated, internal splice joint sealed with bulb type gasketing on both mating modules to minimize on-site labor and meet indoor air quality standards.
 6. Factory leakage test available for units selected with high pressure, low leakage construction. The unit manufacturer shall provide a witnessed factory leak test on selected units. The cabinet shall be tested at the unit's positive and negative maximum design operating static pressure, [up to 8" of differential static pressure across the

cabinet exterior walls for the entire unit. Cabinet leakage shall not exceed Class 6 leakage per ASHRAE Standard 111 or 1% of supply air volume, whichever is greater] [up to +5"/-6" of differential static pressure across the cabinet exterior walls for the entire unit. Cabinet leakage shall not exceed 0.50 CFM/sq. ft. of casing surface area]. All supply and return opening shall be sealed. Air pressure and flow shall be measured by a third party calibrated and certified apparatus. The testing shall be performed at the factory. Owner's representative shall select on unit to be tested at the time of order. A written test report shall be prepared by the manufacturer and issued to the owner's representative.

7. Factory panel deflection testing available for units selected with high pressure, low leakage construction. The unit manufacturer shall provide a factory deflection test on one unit at the unit's positive and negative maximum design operating static pressure, up to 8" of differential static pressure across the cabinet exterior walls for the entire unit. A deflection limit of L/240 will be demonstrated at this time. "L" is defined as the height of a panel on the side of the unit. Measurement shall be at the mid-point of "L" along the largest panel on one side. Owner's representative shall select on unit to be tested at the time of order. A written test report shall be prepared by the manufacturer and issued to the owner's representative.
8. [A sound baffle shall be secured to the inner liner and constructed of G90 galvanized perforated steel filled with glass fiber insulation.]
9. [An optional 0.044" thick aluminium treadplate shall be secured to the floor panel.]
10. Entire unit shall have a [4] [6] [8] [10] [12]-inch full perimeter base rail for structural rigidity and condensate trapping. The following calculation shall determine the required height of the baserail to allow for adequate drainage. Use the largest pressure to determine base rail height. [(Negative)(Positive) static pressure (in)] (2) + 4" = required baserail height. Should the unit baserail not be factory supplied at this height, the contractor is required to supply a concrete housekeeping pad to make up the difference.]
[The unit shall be equipped with a unitized base and shall overhang the roof curb for positive water runoff and shall seat on the roof curb gasket to provide a positive, weather tight seal. Lifting brackets shall be provided on the unit base to accept cable or chain hooks for rigging the equipment.]
11. [Roof Curb kit of [16"] [20"] [24"] [30"] height shall provide support for the air handler on the building roof and provide a weather protected area for terminating and securing the roof membrane. The roof curb kit shall be manufactured and shipped separately from the air handler.]
12. [Coil piping vestibule [18"] [24"] [30"] shall be factory installed of standard cabinet construction on the coil connection side of the unit. Roofcap

over vestibule shall be a continuous single piece covering both the coil section and the vestibule. Roofcap seams between coil section and vestibule are not allowed.]

- B. Access Doors shall be flush mounted to cabinetry, with minimum of two six inch long stainless steel piano-type hinges, latch and full size (4.5" minimum) handle assembly (provide inspection window for fan section). Door shall swing outward for unit sections under negative pressure (inward for unit sections under positive pressure). Doors limited from swinging inward (such as side access filter sections) on positive pressure sections, shall have a secondary latch to relieve pressure and prevent injury upon access.
- C. Construct drain pans from double sloped stainless steel drain pan with cross break and double sloping pitch to drain connection. Provide drain pans under cooling coil section [fan section]. Drain connection centerline shall be a minimum of 3" above the base rail to aid in proper condensate trapping. Drain connections that protrude from the base rail are not acceptable. There must be a full 2" thickness of insulation under drain pan.

2.04 SUPPLY / RETURN FANS

- A. Provide [DWDI forward-curved] [DWDI airfoil] [beltdrive airfoil plenum] [direct-drive airfoil plenum] [inline][fan array] [DWDI forward curved twin] supply [return] fan(s). Fan assemblies including fan, motor and sheaves shall be dynamically balanced by the manufacturer on all three planes and at all bearing supports. Manufacturer must ensure maximum fan RPM is below the first critical speed.

ECM fan array

1. Provide ECM, motorized impeller supply [return] fan(s). Fan assembly shall include fan, fan base, and a motor and shall be dynamically balanced by the fan manufacturer.
 - a. Inverter shall be integral to the motor and come as an assembly from the fan manufacturer.
 - b. Motor shall be brushless DC type with a permanent magnet rotor.
 - c. Fan section shall come equipped with a motor control panel mounted on the supply [return] fan section. Both line voltage and low voltage wiring shall be done by the factory. Each fan shall have an isolation switch.
 - d. [Unit shall be provided with a ship loose motor control panel for the supply [return] fan section. All motor wiring shall be field supplied and installed]
 - e. Motor control panel shall come equipped with a fused disconnect
 - f. Motor control panel shall come with a low voltage terminal strip and shall include terminals for Fan ON/OFF, 0-10V signal, and fan fault.
 - g. ECM motor control panel SCCR shall be at

least 65kA

- h. [Unit shall come equipped with an isolation damper upstream of each fan in the array. Damper shall be equipped with an adjustable, weighted counter balance to minimize static pressure loss]

DDPL fan array

1. Fan array shall have number of fans as scheduled.
2. Fan array section shall come with sound absorbing panels installed around each fan.
3. Fan array shall have fans individually isolated with [Rubber in Shear(RIS)][spring] isolation.
4. Walk in section placed downstream for motor access. [Section shall come installed with tread plate installed in the floor. [Section shall come with motor removal hoist installed]
5. [Unit shall be equipped with a manual block-off plate for mounting in the fan inlet][Unit shall come equipped with an isolation damper upstream of each fan in the array. Damper shall be equipped with an adjustable, weighted counter balance to minimize static pressure loss][Unit shall come equipped with an actuated damper upstream of each fan. An external signal shall close the damper in the event of a fan failure.]
6. [Fan array section shall come with an externally mounted junction box to allow for field wiring of the fan array motors]
7. [Fan section shall come equipped with motor control panel with short circuit protection complete with variable frequency drives.]
 - a. [Fan array shall be equipped with one variable frequency drive wired to all fans][Fan array shall have a redundant drive wired to all fans]
 - b. [Fan array shall be equipped with one variable frequency drive wired to all fans in a given row in the fan array.]
 - c. [Fan array shall be equipped with on variable frequency drive wired to each of the fans in the fan array]
8. [Motor control panel shall come equipped with a [fused][non-fused] disconnect switch]
9. [Fan array shall be equipped with Piezometer rings to measure airflow][One piezometer ring shall be supplied on [eachfan][each row][one fan] in the fan array]

Multiple direct drive fans

1. Unit shall have [two] [three] [9] [12] blade direct drive class II fans with [2" spring isolation] [rubber-in-shear isolation (fan sizes 36 and smaller)] [2" seismic isolation].
2. [Manual block-off] [Isolation damper [with actuator]] mounted upstream of fan for isolation of individual fans.
3. [Single source power motor control panel with short circuit protection and [Non-fused

disconnect] [fused disconnect] [Circuit breaker] factory wired from panel to motors in conduit. Variable speed control by [Daikin Applied brand VFD(s)] [ABB] [Danfoss].] [Fan on-off and speed control by others shall be provided.]

Q-PAC fan array

1. The fan array will be arranged with high performance direct drive, single inlet, plenum fans with backwards inclined, high efficiency welded-aluminum or high-performance composite impeller with galvanized or aluminum support frame.
2. Manual blank-off plates shall be provided to block fan airflow, one plate to be provided per array. [Optional Backdraft dampers shall be provided to block fan airflow in lieu of blank-off plates.]
3. The fans are driven by long-life, low-temperature brushless DC electronically commutated motor (EC-Motor) with external rotor and integrated maintenance-free electronic circuitry and electronics. The motor is manufactured with maintenance-free, permanently lubricated ball bearings and shall be statically and dynamically balanced in accordance with ISO 1940 part 1. The motor shall be closed, protection level IP 54, thermal class 155 with permissible operating temperature of -13°F to 140°F. Motor efficiency class shall comply with IE4. Fan characteristic curves indicate measurements on a chamber test in accordance with ISO5801. The three-phase external rotor motor integrated into the fan hub meets the requirements for circulating electric machines set forth in DIN EN 60 034-1 (VDE 0530 Part 1).
 - a. Fan Array shall be listed per UL 1995.
 - b. Fan assemblies shall be prewired with wire whips and plug connectors.
 - c. Fan system manufacturer must stock replacement parts in North America.
4. The fan bulkhead wall shall be constructed in a manner for easy field assembly, constructed of 14 gauge G90 formed sheet metal. The bend profile at each panel's seam shall provide vertical structural support for the bulkhead wall.
5. The control panel shall include an external disconnect and shall be UL or ETL listed. [Each panel contains a lockable Hand/Off/ Auto switch for optional manual speed control. The panel accepts a 0-10VDC signal when in Auto mode and can be controlled locally when in Hand Mode.] [The panel shall be provided with a BACnet compatible controller capable of monitoring the array's airflow, total static pressure, power consumption, RPM, and individual fan alarm status and specific cause of alarm. Controller shall be configurable for fan speed control via BACnet interface (MS/TP), 0-10 VDC input, 4-20 mA input, constant airflow, or duct static pressure (static pressure sensor to be field provided and mounted). Control panel shall be equipped with relays for locking between other electrically driven components.]

- 6. There is a system alarm contact that the BAS can use to check the status of the Q-PAC System. There is a system enable contact that the BAS can use to enable or disable the Q-PAC System, along with a safety circuit terminations.
 - 7. All Q-PAC components shall be sized to fit through a 20" x 40" access opening.
 - B. Bearings shall be self-aligning, grease lubricated, ball or roller bearings with extended copper lubrication lines to access side of unit. Grease fittings shall be attached to the fan base assembly near access door. If not supplied at the factory, contractor shall mount copper lube lines in the field.
 - C. Fan and motor shall be mounted internally on a steel base. Factory mount motor on slide base that can be slid out the side of unit if removal is required. Provide access to motor, drive, and bearings through hinged access door. Fan and motor assembly shall be mounted on [rubber-in-shear vibration type isolators inside cabinetry.] [2" deflection spring vibration type isolators inside cabinetry] [unit base, rigid mounted.] [Seismic snubbers shall be provided.]
- terminal box sized to NFPA 70.
 - C. [Provide [marine light] [marine light and GFI receptacle] in [fan] [each] section mounted and wired to a junction box and on-off switch mounted on the outside of the cabinet.
 - D. Fan motors shall be [1200] [1800] [3600] rpm, [open drip-proof (ODP)] [totally enclosed fan-cooled (TEFC)] [1800/ 1200 rpm, 2 Speed/2 Winding (ODP) (TEFC)] [1800/900 rpm, 2 Speed/1 Winding (ODP) (TEFC)] type. Motors shall be [standard efficiency.] [high efficiency to meet EPC requirements.] [premium efficiency.] Electrical characteristics shall be as shown in schedule.
 - E. [Air handler manufacturer shall provide and mount conduit and wiring from each fan motor terminated at [an external junction box.] [a non-fused] [a fused] [a circuit breaker] type disconnect switch factory wired. The disconnect switch shall be furnished with a rotary or switch-blade type handle that can be padlocked in the 'off' position.] [A motor starter [IEC] [NEMA] type shall be provided.]
 - F. [Air handler manufacturer shall provide and mount [Daikin Applied] [ABB] [Danfoss] variable speed drive with electrical characteristics as shown on project schedule. [A two-contactor type bypass switch shall be provided.] [A line reactor shall be provided.]
 - G. [Air handler manufacturer shall provide and mount a handoff-auto (HOA) switch.]
 - H. [Air handler manufacturer shall provide and mount a [24V] [120V] transformer.]
 - I. [Manufacturer must provide ASHRAE 90.1 Energy Efficiency equation details for individual equipment to assist Building Engineer for calculating system compliance.]

2.05 BEARINGS AND DRIVES

(Not applicable to direct drive fans or fan array)

- A. Bearings: Basic load rating computed in accordance with AFBMA - ANSI Standards, [L-50 life at 200,000 hours – all DWDI fans] [L-50 life at 500,000 hours – DWDI fans on unit sizes 003 - 035], [L-50 life at 400,000 hours all belt-drive airfoil plenum fans and DWDI fans on unit sizes greater than 035] [L-50 life 1,000,000 hours – DWDI fans on unit sizes 003 – 035] [L-50 life at 600,000 hours – all inline fans], heavy duty pillow block type, self-aligning, grease-lubricated ball bearings.
- B. Shafts shall be solid, hot rolled steel, ground and polished, keyed to shaft, and protectively coated with lubricating oil. Hollow shafts are not acceptable.
- C. V-Belt drives shall be cast iron or steel sheaves, dynamically balanced, bored to fit shafts and keyed. [Fixed sheaves, matched belts, and drive rated based on motor horsepower] [Variable and adjustable pitch sheaves selected so required RPM is obtained with sheaves set at mid-position and rated based on motor horsepower. Contractor to furnish fixed sheaves at final RPM as determined by balancing contractor]. Minimum of 2 belts shall be provided on all fans with 10 HP motors and above. Standard drive service factor shall be [1.1 S.F. (for 1/4 HP – 7.5 HP)] [1.3 S.F. (for 10HP and larger)], calculated based on fan brake horsepower.

2.06 ELECTRICAL

- A. The air handler(s) shall be ETL and ETL-Canada listed by Intertek Testing Services, Inc. Units shall conform to bi-national standard ANSI/UL Standard 1995/CSA Standard C22.2 No. 236.
- B. Wiring Termination: Provide terminal lugs to match branch circuit conductor quantities, sizes, and materials indicated. Enclosed terminal lugs in

2.07 COOLING AND HEATING COIL SECTIONS

- A. Provide access to coils from [both sides] [connection side] [opposite side] of unit for service and cleaning. Enclose coil headers and return bends fully within unit casing. Unit shall be provided with coil connections that extend a minimum of 5" beyond unit casing for ease of installation. Drain and vent connections shall be provided exterior to unit casing. Coil connections must be factory sealed with grommets on interior and exterior and gasket sleeve between outer wall and liner where each pipe extends through the unit casing to minimize air leakage and condensation inside panel assembly. If not factory packaged, Contractor must supply all coil connection grommets and sleeves. Coils shall be removable through side and/or top panels of unit without the need to remove and disassemble the entire section from the unit.
 - 1. Identify fin, tube & casing material type and thickness.
 - 2. Show coil weights (shipping & operating).
 - 3. State air and fluid flow amounts with its associated pressure drops. For steam coils, indicate steam pressure and condensate load.

4. Indicate entering & leaving air and water temperatures. For refrigerant coils, indicate saturated suction temperature (SST).
- B. Water Coils:**
1. Certification - Acceptable water coils are to be certified in accordance with AHRI Standard 410 and bear the AHRI label. Coils exceeding the scope of the manufacturer's certification and/or the range of AHRI's standard rating conditions will be considered provided the manufacturer is a current member of the AHRI Air-Cooling and Air-Heating Coils certification programs and that the coils have been rated in accordance with AHRI Standard 410. Manufacturer must be ISO 9002 certified.
 2. Headers shall consist of seamless copper tubing to assure compatibility with primary surface. Headers to have intruded tube holes to provide maximum brazing surface for tube to header joint, strength, and inherent flexibility. Header diameter should vary with fluid flow requirements.
 3. Fins shall have a minimum thickness of [[0.0075"] [0.0095"] of aluminum] or [0.006"] [0.0075"] [0.0095"] copper]] plate construction. Fins shall have full drawn collars to provide a continuous surface cover over the entire tube for maximum heat transfer. Tubes shall be mechanically expanded into the fins to provide a continuous primary to secondary compression bond over the entire finned length for maximum heat transfer rates. Bare copper tubes shall not be visible between fins.
 4. Coil tubes shall be 5/8 inch (16mm) OD seamless copper, 0.020" [0.025"] [0.035"] [0.049"] nominal tube wall thickness, expanded into fins, brazed at joints. Soldered U-bends shall be provided to minimize the effects of erosion and premature failure having a minimum tube wall thickness of 0.025".
 5. Coil connections shall be [N.P.T. threaded carbon steel] [butt weld carbon steel] [O.D. sweat copper] [threaded red brass] with connection size to be determined by manufacturer based upon the most efficient coil circuiting. Vent and drain fittings shall be furnished on the connections, exterior to the air handler. Vent connections provided at the highest point to assure proper venting. Drain connections shall be provided at the lowest point to insure complete drainage and prevent freeze-up.
 6. Coil casings shall be a formed channel frame of [galvanized steel] [stainless steel]. Water heating coils, 1 & 2 row only (sans 5M type) shall be furnished as uncased to allow for thermal movement and slide into a pitched track for fluid drainage.
- C. Refrigerant Coils:**
1. Certification - Acceptable refrigerant coils are to be certified in accordance with AHRI Standard 410 and bear the AHRI label. Coils exceeding the scope of the manufacturer's certification and/or the range of AHRI's standard rating conditions will be considered provided the manufacturer is a current member of the AHRI Air-Cooling and Air-Heating Coils certification programs and that the coils have been rated in accordance with AHRI Standard 410. Manufacturer must be ISO 9002 certified.
 2. Coils designed for use with Refrigerant [R-22] [R134a] [other]. Fins shall have a minimum thickness of [[0.0075"] [0.0095"] of aluminum] or [0.006"] [0.0075"] [0.0095"] copper]] plate construction with full drawn collars to provide a continuous surface cover over the entire tube for maximum heat transfer. Tubes shall be mechanically expanded into the fins to provide a continuous primary-to-secondary compression bond over the entire finned length for maximum heat transfer rates. Bare copper tube shall not be visible between fins.
 3. Refrigerant coils shall be provided with round seamless 5/8" O.D. copper tubes on 1-1/2" centers, staggered in the direction of airflow. All joints shall be brazed.
 4. Sweat type copper suction connections located at the bottom of the suction headers for gravity oil drainage. Coils shall be uniformly circuited in a counterflow manner for [single circuit] [row] [face] [interlaced] [interlaced face split] capacity reduction. Pressure type liquid distributors used. Coils shall be tested with 315 pounds air pressure under warm water, and suitable for 250 psig working pressure.
- D. Steam Coils:**
1. Certification - Acceptable steam coils are to be certified in accordance with AHRI Standard 410 and bear the AHRI label. Coils exceeding the scope of the manufacturer's certification and/or the range of AHRI's standard rating conditions will be considered provided the manufacturer is a current member of the AHRI Air-Cooling and Air-Heating Coils certification programs and that the coils have been rated in accordance with AHRI Standard 410. Manufacturer must be ISO 9002 certified.
 2. Fins shall have a minimum thickness of [[0.0075"] [0.0095"] [0.012" (1" dia. tubes only)] of aluminum] or [0.006" (5/8" tube dia. only)] [0.0075"] [0.0095"] copper]] with full drawn collars to provide a continuous surface cover over the entire tube for maximum heat transfer. Tubes shall be mechanically expanded into the fins to provide a continuous primary-to-secondary compression bond over the entire finned length for maximum heat transfer rates. Bare copper tubes shall not be visible between fins.
 3. Steam coils shall be provided with round seamless [5/8" O.D. copper [0.020"] [0.025"] [0.035"] [0.049"] or [1" O.D. copper [0.025"] [0.049"] tubes. Tubes on two-row coils are staggered in the direction of airflow. All joints shall be brazed.
 4. Steam coil headers shall be made of nonferrous materials using seamless copper tubing with intruded tube holes to permit expansion and contraction without creating undue stress or

strain. Both the supply and return headers shall be completely encased by the coil casing. Coil shall be pitched in the unit to assure positive condensate drainage. Steam coils shall be furnished as uncased to allow for thermal movement and slide into a pitched track for drainage. Orificed baffle plates shall be installed in the supply connection to ensure proper diffusion of entering steam.

5. Steam coils shall be tested with 315 pounds air pressure under warm water and suitable for 150 psig working pressures.
- E. [Horizontal Tube Integral Face and Bypass Coil]
1. Horizontal tube integral face and bypass coils shall consist of multiple alternating heating sections and bypass sections, with airflow distributed to each by interlocking wrap-a-round "clamshell" style dampers; linkage to be stainless steel. Coils shall be suitable for hot water or steam and continuous operation at 200 psig and 400 F degrees. Heating elements to consist of multi-row, multi-pass extended heat transfer surface; coil shall carry AHRI 410 certification as to ratings. Welding and brazing shall be done by ASME qualified personnel.
 2. Tubes shall be 5/8" diameter seamless copper, 0.035" average wall thickness. Fins shall be continuous patterned plate, .0075" thick aluminum with full fin collars. Joints shall be silver brazed. Headers shall be single piece carbon steel, with no separate disks or caps welded or brazed into header ends. Connections shall be steel and shall be welded to header barrels.
 3. Casings and dampers shall be minimum 16 gauge mill galvanized steel; top and bottom casing panels to be double flanged for stacking. End casings shall have smooth, embossed tube holes to provide adequate bearing surface for tubes to avoid abrasion during expansion and contraction. Flexible connectors shall not be required.]
- F. [Vertical Tube Integral Face and Bypass Coil]
1. Vertical tube integral face and bypass coils shall consist of multiple alternating heating sections and bypass sections, with airflow distributed to each by interlocking wrap-a-round "clamshell" style dampers; linkage to be stainless steel. Coils shall be suitable for hot water or steam and continuous operation at 200 psig and 400 F degrees. Heating elements to consist of multi-row, multi-pass extended heat transfer surface; coil shall carry AHRI 410 certification as to ratings. Welding and brazing shall be done by ASME qualified personnel.
 2. Hot water applications shall be furnished with 5/8" outside diameter tubes with .035" tube wall thickness. Steam applications shall be furnished with a non-freeze, tube-within-a-tube design that consists of an outer tube that is 5/8" outside diameter tubes with .035" tube wall thickness and an inner tube that is 3/8" outside diameter with 0.020" wall thickness. Fins shall be a helical fin design that is 1/2" high, 0.012" thick copper, solder coated.

3. Supply and Return headers shall be located at the base of the coil. Hot water coils shall employ return bends. Steam coils shall be capped to allow free thermal movement. Headers shall be carbon steel with male pipe thread connections.
4. The casing shall be 12 gauge galvanized steel. The dampers shall be 16 gauge galvanized steel with aluminum hinges, stainless steel pins, linkage & connecting bars with oilite bearings.]

2.08 GAS HEAT MODULE

- A. The air handling unit shall include a natural gas heating section. The gas furnace shall be natural gas fired heating module(s) factory installed downstream of the supply air fan in the heat section.
- B. [The heating module shall be a tubular design with in-shot gas burners. The heat exchanger tubes shall be constructed of stainless steel. The module shall have an induced draft fan that will maintain a negative pressure in the heat exchanger tubes for the removal of the flue gases.] [High efficiency heat exchanger shall be a primary drum and multi-pass tubular secondary constructed of titanium stainless steel, and shall be of a floating design to minimize stresses during heating and cooling cycles. Tubing used for the heat exchanger shall comply with ASTM A268 or ASTM 249 (as applicable). Secondary tubes shall be swaged into panels and welded to provide a secure joint and air tight assembly. All heat transfer surfaces shall be inside the casing and in the air stream.]
- C. [Gas-fired duct furnaces provided shall have a tubular heat exchanger constructed of (Type 409 Stainless Steel .044 minimum wall thickness produced to ASTM A268).]
- D. [Duct furnace to provide a minimum combustion efficiency of 90% through the entire firing range, exceeding the ASHRAE 90.1 minimum requirement for steady state efficiency.]
- E. [High efficiency gas heat section shall be provided with condensate drain(s). Installer is responsible for materials and final connection of drain(s) for condensate disposal.]
- F. [High efficiency furnaces require a Category IV venting system certified to UL 1738 / ULC S636. Installer is responsible for material and final vent installation in accordance with manufactures instructions provided.]
- G. The Duct Furnace models shall be listed by Intertek Testing Services (ITS / ETL) for operation on Natural or Propane gas to the current edition of ANSI Z83.8 Standard for Gas-Fired Duct Furnaces. Duct furnaces are for installation on the positive pressure side of the circulating air blower, only.
- H. [Gas Module shall be [2] [4] stages of control] [Gas module shall have [5:1] [10:1] [20:1] [25:1] modulating control.]
 - I. Each burner module shall have [two flame roll-out safety protection switches and] a high temperature limit switch that will shut the gas valve off upon detection of improper burner manifold operation.

- J. The induced draft fan shall have an airflow safety switch that will prevent the heating module from turning on in the event of no airflow in the flue chamber.
- K. Field installed heating modules shall require a field ETL certification. The manufacturer's rooftop unit ETL certification shall cover the complete unit including the gas heating modules.
- L. Individual Duct Furnaces shall incorporate a Direct Spark Ignition control module that is design certified by a recognized national testing agency. The control shall provide:
 1. 100% safety shut-off
 2. A 15 second minimum pre-purge period prior to trial for ignition
 3. High energy direct spark ignition of main burners
 4. Electronic flame supervision incorporating a 0.8 second flame failure response time
 5. Up to 2 additional ignition retries preceded by an interpurge period
 6. A minimum 30 second post-purge
 7. Automatic reset after one hour to initiate additional ignition trials if lockout occurs during heat call
 8. An LED indicator light to provide a flash code to identify the operating condition of the control
- B. The filter enclosure shall include side access extruded aluminum tracks to support the gas phase filter cassettes. Each gas phase filter shall be supported by two upper and lower extruded aluminum tracks i.e. two support tracks at the inlet face and two support and sealing tracks at the outlet face.
- C. These tracks shall incorporate formed profile features to ensure that the filters are properly sealed into the enclosure. Simple 'L' tracks or angle supports that permit high leakage and inefficient sealing integrity are not permitted. The filter tracks shall ensure that the gas phase filter cassettes are permanently fixed in position and sealed to minimize bypass of air around the filters and to ensure that the entire contaminated air-stream passes through the filters.
- D. Each filter track shall include two hard-extruded type POM plastic strips embedded into, and protruding above, the horizontal surface of the track. These strips will minimize the surface area in contact with the filter cassettes and provide a plastic sliding surface with inherent lubricating properties to minimize friction and facilitate ease of installation and removal when sliding the gas phase filters into and out of the tracks.
- E. The filter outlet face (or downstream) upper and lower support and sealing tracks will each include a tubular, compressible, EPDM gasket inserted into a formed cavity in the sealing face of the track. Each of these tracks shall also include a vertical extruded aluminum flange that shall guide the gas phase filter into position and position the filter to guarantee that the tubular gasket is adequately compressed to seal between the filter and the track to minimize any by-pass of unfiltered air. The tubular gasket shall be treated with a polymer coating to reduce friction when sliding the gas phase filter into the track.
- F. The vertical flange in the track shall fit into notches located on the gas phase filter cassette and ensure that the cassette is properly positioned in the track. The tubular gasket shall be compressed by the action of installing the gas phase cassette into the side access tracks.
- G. The cassette shall be formed completely from injection molded, recyclable (or incinerable), high-impact polystyrene (HIPS). The plastic components that form the cassette shall be connected together using internal high pressure, snap-lock connectors formed into the connecting components. No glues or solvents shall be allowed to be used in the manufacture or construction of the cassette to prevent contamination of both the chemical media and the air-stream by off-gassing of VOCs.
- H. All surfaces of the cassette should be true and offer external squareness. The cassette construction shall be of precision close tolerance construction having external dimensional and square ness tolerances of +/- 2mm. The cassette shall be capable of operating effectively in humidity range of 5% - 99% and temperature range of -5°F (-20°C) to 130°F (55°C).
- I. Chemical media shall be supported between

2.09 PARTICULATE FILTERS

- A. [Filter section with filter racks and guides with hinged and latching access doors on either, or both sides, for side loading and removal of filters] [Filter section with front loading frames and clips].
- B. Filter media shall be UL 900 listed, Class I or Class II.
- C. [Flat] [Angle] arrangement with [2", 50mm] [4", 100mm] deep [pleated] [disposable] panel filters.
- D. [Bag] [Cartridge] type arrangement with holding frames suitable for [2" (50 mm)], [4" (100 mm)] prefilter and final filter media and blank-off sheets, extended surface [bag] [cartridge] media filters with [60-65] [80-85] [90-95] percent dust spot efficiency. Bag filter media [12" (305 mm)] [15" (381 mm)] [19" (483 mm)] [22" (559 mm)] [30" (762 mm)] [36" (914 mm)] deep. Cartridge filter media is [4" (50 mm)] [12" (305 mm)] deep. [Provide microbial resistant Intersept? coating on all filters.] Designed for [side] [front] loading of filters.
- E. [Manufacturer shall supply magnehelic gauge to read pressure drop across the filter bank for scheduling filter replacement. Design shall be recessed into the cabinet to minimize chances for damage during shipment and installation.]

2.010 [GAS-PHASE FILTRATION

- A. Side access tracks shall accommodate AAF International's [Cleanroom Grade (CG)] [Medium Duty (MD)] [Heavy Duty (HD)] gas-phase filter cassettes.
- I. Chemical media shall be supported between

aerodynamically tapered screens with very low drag coefficient (for energy efficiency). Injection molded high-impact polystyrene screens shall form individual media beds assembled into a V-bank configuration.

- J. No nose cavities shall be allowed in cassettes. The inlet and outlet screens shall be parallel and the inlet and outlet face areas shall be equal to ensure equal and complete utilization of the chemical media. The screen openings shall have a maximum width of 2-mm to ensure full retention of the chemical media and to eliminate downstream fouling.
- K. The screens shall be structurally reinforced with molded plastic ribs to minimize deflection of the screen caused by the weight of the chemical media. The ribs shall span in both directions and shall be orthogonal to each other. The inlet and outlet screens shall have a minimum thickness of 1.90-mm. A spacer shall be utilized at 150-mm intervals to accurately distance the two screens and maintain squareness and a constant bed depth after filling with chemical media.
- L. The side plates of the cassette shall be completely flat and planar and without protrusions to ensure that adjacent cassette mate accurately. All flanges shall be internal. No external flanges shall used. A 25mm wide gasket shall be mounted on each side plate to seal between adjacent cassettes. A scribed line formed into the side plate during molding shall determine the accurate positioning of the gasket. The gasket shall extend completely from the bottom to the top of the side plate and the edge of the gasket shall be contiguous with the face of the cassette. The gasket material shall be adhesive coated (with an acryl-based adhesive), semi-closed-cell EPDM foam and shall have a Durometer of 50-70. The material shall have good resistance to UV, humidity, high and low temperatures, and chemicals such as acids and alkalis, and fats and grease.
- M. A V-shaped Butterfly® Gasket shall be located horizontally along the upper and lower edges of the air leaving, or sealing, face of the cassette when the cassette is oriented for horizontal airflow. Two (2) 10-mm long, 0.5-mm thick, flexible “wings” shall be molded into a 16-mm wide, 1.5mm thick, base. When the cassette is installed the wings of the Butterfly gasket shall engage and envelop the tubular gasket that is installed in the extruded aluminum track providing a complete seal. The Butterfly gasket shall be extruded Polyurethane plastic.
- N. No heavy metals (such as Cadmium) nor regulated substances, such as CFC's and halogen gases shall be used during the manufacturing process nor be contained in the product itself.
- O. Cassette side plates shall not incorporate the cassette filling ports. Chemical media filling ports shall be located on the face of the cassette. The ports shall be covered and sealed using reinforced injection molded polypropylene covers. The covers shall be fixed to the cassette at a minimum of three locations, being each end and in the center, with high strength, bayonet style, plastic rivets. The bayonet shall cause the rivet to expand and form a tight connection.

The end of the bayonet shall be barbed to prevent withdrawal and loosening of the connection, it shall also completely plug the center of the rivet and prevent air leakage through the rivet.

- P. The sealing perimeter of the cassette face shall be completely planar with top, bottom and side flange faces being completely flush. No setbacks or gaps shall be allowed. The outer edges of the top and bottom flanges shall be completely flush with the top and bottom surfaces of the cassette. The cassette shall include a precision molded slot positioned to accept a guide located on the surface of the support track. The slot and guide combination will ensure that the cassette is accurately positioned in the mounting track ensuring full contact and proper compression of the track-mounted gasket.
- Q. Physical characteristics and performance shall be as follows: [Cleanroom Grade (CG) Cassette – Nominal size 24"H × 12"W × 12"D with media holding capacity of 0.7 cubic feet in a 1" thick 'V' bank arrangement. Rated pressure drop at 500 fpm shall be [0.047 utilizing SAAFOxidant] [0.56 utilizing SAAFCarb] [0.57 utilizing SAAFBlend] Chemical Media. Chemical media utilization index shall be 92% or greater.]

[Medium Duty (MD) Cassette – Nominal size 6"H × 24"W × 18"D with media holding capacity of 0.5 cubic feet in a 1" thick 'V' bank arrangement. Rated pressure drop at 500 fpm shall be [0.031 utilizing SAAFOxidant] [0.35 utilizing SAAFCarb] [0.34 utilizing SAAFBlend] Chemical Media. Chemical media utilization index shall be 92% or greater.]

[Heavy Duty (HD) Cassette – Nominal size 12"H × 24"W × 12"D with media holding capacity of 1.0 cubic feet in a 3" thick 'V' bank arrangement. Rated pressure drop at 250 fpm shall be [0.073 utilizing SAAFOxidant] [0.87 utilizing SAAFCarb] [0.97 utilizing SAAFBlend] Chemical Media. Chemical media utilization index shall be 92% or greater.]

2.11 ADDITIONAL SECTIONS

- A. [Mixing box section shall be provided with [end] [top] [bottom] [left] [right] [no] outside air opening and [end] [top] [bottom] [left] [right] [no] return air opening.
- 1. [Outside air] [Return air] damper[s] shall be low leak, hollow core galvanized steel airfoil blades, fully gasketed and have continuous vinyl seals between damper blades in a galvanized steel frame. Dampers shall have stainless steel jamb seals along end of dampers. Connecting linkage and ABS plastic end caps shall be provided when return and outside air dampers are each sized for full airflow. Return and outside air dampers of different sizes must be driven separately. Damper Leakage: Leakage rate shall be less than two tenths of one percent leakage at 2 inches static pressure differential. Leakage rate tested in accordance with AMCA Standard 500.
- 2. [Outside air] [Return air] damper[s] shall be

- Tamco 9000, [parallel] [opposed] blade, thermally insulated control damper. Return and outside air dampers must be driven separately.
- a. Extruded aluminum (6063-T5) damper frame is not less than 0.080" (2.03 mm) in thickness. Damper frame is 4" (101.6 mm) deep × 1" (25.4 mm), with mounting flanges on both sides of frame.
 - b. Blades are extruded aluminum (6063-T5) airfoil profiles, internally insulated with expanded polyurethane foam and thermally broken. Complete blade has an insulating factor of R-2.29 and a temperature index of 55 (tested to AAMA 1502.7 Test Method).
 - c. Blade seals are extruded EPDM. Frame seals are extruded silicone. Seals are secured in an integral slot within the aluminum extrusions. Blade and frame seals are mechanically fastened to prevent shrinkage and movement over the life of the damper.
 - d. Bearings are composed of a Celcon inner bearing (fixed around a 7/16" (11.11 mm) aluminum hexagon blade pivot pin) rotating within a polycarbonate outer bearing inserted in the frame. This eliminates action between metal-to-metal or metal-to-plastic riding surfaces.
 - e. Adjustable 7/16" (11.11 mm) hexagonal drive rod, U-bolt fastener, and hexagonal retaining nuts are zinc-plated steel. These provide a positive connection to blades and linkage.
 - f. Aluminum and corrosion-resistant zinc-plated steel linkage hardware is installed in the frame side, complete with cup-point trunnion screws for a slip-proof grip.
 - g. Dampers are designed for operation in temperatures ranging from -40°F (-40°C) to 212°F (100°C).
 - h. Leakage Class 1A at 1 in w.g. (0.25 kPa) static pressure differential. Standard air leakage data is certified under the AMCA Certified Ratings Program.
 - i. Dampers are custom made to required size, without blanking off free area.
3. [Outside air] [Return air] damper[s] shall be Tamco 1000, [parallel] [opposed] blade, low leak airfoil control damper. Return and outside air dampers must be driven separately.
 - a. Extruded aluminum (6063-T5) damper frame is not less than 0.080" (2.03 mm) in thickness. Damper frame is 4" (101.6 mm) deep × 1" (25.4 mm), with mounting flanges on both sides of frame.
 - b. Blades are extruded aluminum (6063-T5) airfoil profiles.
 - c. Blade seals are extruded EPDM. Frame seals are extruded silicone. Seals are secured in an integral slot within the aluminum extrusions. Blade and frame seals are mechanically fastened to prevent shrinkage and movement over the life of the damper.
 - d. Bearings are composed of a Celcon inner bearing (fixed around a 7/16" (11.11 mm) aluminum hexagon blade pivot pin) rotating within a polycarbonate outer bearing inserted in the frame. This eliminates action between metal-to-metal or metal-to-plastic riding surfaces.
 - e. Adjustable 7/16" (11.11 mm) hexagonal drive rod, U-bolt fastener, and hexagonal retaining nuts are zinc-plated steel. These provide a positive connection to blades and linkage.
 - f. Aluminum and corrosion-resistant zinc-plated steel linkage hardware is installed in the frame side, complete with cup-point trunnion screws for a slip-proof grip.
 - g. Dampers are designed for operation in temperatures ranging from -40°F (-40°C) to 212°F (100°C).
 - h. Leakage Class 1A at 1 in w.g. (0.25 kPa) static pressure differential. Standard air leakage data is certified under the AMCA Certified Ratings Program.
 - i. Dampers are custom made to required size, without blanking off free area.
 4. [Outside air] [Return air] damper[s] shall be Ruskin CD60, [parallel] [opposed] blade, low leak airfoil control damper. Return and outside air dampers must be driven separately.
 - a. Control dampers shall be produced in an ISO9001 certified factory.
 - b. Frame shall be one-piece uniframe construction of 16 ga. (1.6) galvanized steel roll formed hat channel structurally equivalent to a minimum 13 ga. (2.4) frame.
 - c. Blades shall be 14 ga. (2.0) equivalent galvanized steel, roll-formed airfoil type for low pressure drop and low noise generation.
 - d. Blade edge seals shall be Ruskiprene™ TPV type or equivalent mechanically locked into the blade edge. Adhesive or clip-on type seals are unacceptable.
 - e. Jamb seals shall be stainless steel chambered compression type to prevent leakage between blade end and damper frame. Blade end overlapping frame is unacceptable.
 - f. Multiple section dampers must have factory installed jackshafts unless clearly eliminated by engineer.
 - g. Bearings shall be 304 stainless steel, oil impregnated, and self-lubricating sleeve type with a 450 pound (204 kg) minimum radial crush load. Bearings shall turn in extruded holes in the damper frame.
 - h. Axles shall be hexagonal positively locked into the damper blade.
 - i. Linkage shall be concealed out of airstream, within the damper frame to reduce pressure

- drop and noise.
- j. Temperature limits shall be -72°(-58°C) to +275°F (+135°C).
 - k. Damper shall be tested and licensed in accordance with AMCA 511 for Air Performance and Air Leakage.
 - l. Damper widths from 12" to 60" (305 to 1524) wide shall not leak any greater than 3 cfm/sq.ft. at 1" w.g. (15.2 l/s-m² at .25 kPa).
5. [Outside air] [Return air] damper[s] shall be Greenheck VCD33 [stainless steel] [galvanized], [parallel] [opposed] blade, low leak airfoil control damper. Return and outside air dampers must be driven separately.
- a. Dampers shall consist of: a 16 ga. (1.5mm) [galvanized steel] [304 stainless steel] channel frame with 5 in. (127mm) depth; airfoil shaped, [galvanized steel] [304 stainless steel] double skin construction blades (14 ga. [2mm] equivalent thickness); blades shall be completely symmetrical relative to their axle pivot point, presenting identical resistance to airflow in either direction or pressure on either side of the damper; 1/2 in. (6mm) dia. plated steel axles turning in synthetic (acetal) sleeve bearings; TPE blade seals for 200°F (93°C) maximum temperature; flexible stainless steel jamb seals; and external (out of the airstream) blade-to-blade linkage.
6. [Outside air] [Return air] damper[s] shall be Greenheck VCD43 aluminum, [parallel] [opposed] blade, low leak airfoil control damper. Return and outside air dampers must be driven separately.
- a. Dampers shall consist of: heavy gauge aluminum frame (0.125 in. [3.2mm] thick) with 5 in. (127mm) depth formed into a structural hat channel shape; airfoil shaped, extruded aluminum blades (0.063 in. [1.6mm] thick) with metal blade to blade overlap (seal to seal only contact is not acceptable); blades shall be completely symmetrical relative to their axle pivot point, presenting identical resistance to airflow and operation in either direction through the damper (blades that are non-symmetrical relative to their axle pivot point or utilize blade stops larger than 1/2 in. (13mm) are unacceptable); 1/2 in. (13mm) dia. plated steel axles turning in synthetic (acetal) sleeve bearings; TPE blade seals; flexible stainless steel jamb seals; and external (out of the airstream) blade-to-blade linkage.
7. [Outside air] [Return air] opening[s] shall be provided without a damper.]
- B. [Economizer section shall be provided with [end] [top] [bottom] [left] [right] [internal] [no] outside air opening, [end] [top] [bottom] [left] [right] [internal] [no] return air opening and [end] [top] [bottom] [left] [right] [internal] [no] exhaust air opening.
- 1. [Outside air] [Return air] [Exhaust air] damper[s] shall be low leak, hollow core galvanized steel airfoil blades, fully gasketed and have continuous vinyl seals between damper blades in a galvanized steel frame. Dampers shall have stainless steel jamb seals along end of dampers. Linkage and ABS plastic end caps shall be provided when return and outside air dampers sized for full airflow. Return and outside air dampers of different sizes or very large dampers and exhaust dampers must be driven separately. Damper Leakage: Leakage rate shall be less than two tenths of one percent leakage at 2 inches static pressure differential. Leakage rate tested in accordance with AMCA Standard 500.
2. [Outside air] [Return air] [Exhaust air] damper[s] shall be Tamco 9000, [parallel] [opposed] blade, thermally insulated control damper. Return, outside, and exhaust air dampers must be driven separately.
- a. Extruded aluminum (6063-T5) damper frame is not less than 0.080" (2.03 mm) in thickness. Damper frame is 4" (101.6 mm) deep x 1" (25.4 mm), with mounting flanges on both sides of frame.
 - b. Blades are extruded aluminum (6063-T5) airfoil profiles, internally insulated with expanded polyurethane foam and thermally broken. Complete blade has an insulating factor of R-2.29 and a temperature index of 55 (tested to AAMA 1502.7 Test Method).
 - c. Blade seals are extruded EPDM. Frame seals are extruded silicone. Seals are secured in an integral slot within the aluminum extrusions. Blade and frame seals are mechanically fastened to prevent shrinkage and movement over the life of the damper.
 - d. Bearings are composed of a Celcon inner bearing (fixed around a 7/16" (11.11 mm) aluminum hexagon blade pivot pin) rotating within a polycarbonate outer bearing inserted in the frame. This eliminates action between metal-to-metal or metal-to-plastic riding surfaces.
 - e. Adjustable 7/16" (11.11 mm) hexagonal drive rod, U-bolt fastener, and hexagonal retaining nuts are zinc-plated steel. These provide a positive connection to blades and linkage.
 - f. Aluminum and corrosion-resistant zinc-plated steel linkage hardware is installed in the frame side, complete with cup-point trunnion screws for a slip-proof grip.
 - g. Dampers are designed for operation in temperatures ranging from -40°F (-40°C) to 212°F (100°C).
 - h. Leakage Class 1A at 1 in w.g. (0.25 kPa) static pressure differential. Standard air leakage data is certified under the AMCA Certified Ratings Program.
 - i. Dampers are custom made to required size, without blanking off free area.
3. [Outside air] [Return air] [Exhaust air] damper[s] shall be Tamco 1000, [parallel] [opposed]

- blade, low leak airfoil control damper. Return, outside, and exhaust air dampers must be driven separately.
- a. Extruded aluminum (6063-T5) damper frame is not less than 0.080" (2.03 mm) in thickness. Damper frame is 4" (101.6 mm) deep × 1" (25.4 mm), with mounting flanges on both sides of frame.
 - b. Blades are extruded aluminum (6063-T5) airfoil profiles.
 - c. Blade seals are extruded EPDM. Frame seals are extruded silicone. Seals are secured in an integral slot within the aluminum extrusions. Blade and frame seals are mechanically fastened to prevent shrinkage and movement over the life of the damper.
 - d. Bearings are composed of a Celcon inner bearing (fixed around a 7/16" (11.11 mm) aluminum hexagon blade pivot pin) rotating within a polycarbonate outer bearing inserted in the frame. This eliminates action between metal-to-metal or metal-to-plastic riding surfaces.
 - e. Adjustable 7/16" (11.11 mm) hexagonal drive rod, U-bolt fastener, and hexagonal retaining nuts are zinc-plated steel. These provide a positive connection to blades and linkage.
 - f. Aluminum and corrosion-resistant zinc-plated steel linkage hardware is installed in the frame side, complete with cup-point trunnion screws for a slip-proof grip.
 - g. Dampers are designed for operation in temperatures ranging from -40°F (-40°C) to 212°F (100°C).
 - h. Leakage Class 1A at 1 in w.g. (0.25 kPa) static pressure differential. Standard air leakage data is certified under the AMCA Certified Ratings Program.
 - i. Dampers are custom made to required size, without blanking off free area.
4. [Outside air] [Return air] [Exhaust air] damper[s] shall be Ruskin CD60, [parallel] [opposed] blade, low leak airfoil control damper. Return, outside, and exhaust air dampers must be driven separately.
 - a. Control dampers shall be produced in an ISO9001 certified factory.
 - b. Frame shall be one-piece uniframe construction of 16 ga. (1.6) galvanized steel roll formed hat channel structurally equivalent to a minimum 13 ga. (2.4) frame.
 - c. Blades shall be 14 ga. (2.0) equivalent galvanized steel, roll-formed airfoil type for low pressure drop and low noise generation.
 - d. Blade edge seals shall be Ruskiprene™ TPV type or equivalent mechanically locked into the blade edge. Adhesive or clip-on type seals are unacceptable.
 - e. Jamb seals shall be stainless steel chambered compression type to prevent leakage between blade end and damper frame. Blade end overlapping frame is unacceptable.
 5. [Outside air] [Return air] [Exhaust air] damper[s] shall be Greenheck VCD33 [stainless steel] [galvanized], [parallel] [opposed] blade, low leak airfoil control damper. Return, outside, and exhaust air dampers must be driven separately.
 - a. Dampers shall consist of: a 16 ga. (1.5mm) [galvanized steel] [304 stainless steel] channel frame with 5 in. (127mm) depth; airfoil shaped, [galvanized steel] [304 stainless steel] double skin construction blades (14 ga. [2mm] equivalent thickness); blades shall be completely symmetrical relative to their axle pivot point, presenting identical resistance to airflow in either direction or pressure on either side of the damper; 1/2 in. (6mm) dia. plated steel axles turning in synthetic (acetal) sleeve bearings; TPE blade seals for 200°F (93°C) maximum temperature; flexible stainless steel jamb seals; and external (out of the airstream) blade-to-blade linkage.
 6. [Outside air] [Return air] [Exhaust air] damper[s] shall be Greenheck VCD43 aluminum, [parallel] [opposed] blade, low leak airfoil control damper. Return, outside, and exhaust air dampers must be driven separately.
 - a. Dampers shall consist of: heavy gauge aluminum frame (0.125 in. [3.2mm] thick) with 5 in. (127mm) depth formed into a structural hat channel shape; airfoil shaped, extruded aluminum blades (0.063 in. [1.6mm] thick) with metal blade to blade overlap (seal to seal only contact is not acceptable); blades shall be completely symmetrical relative to their axle pivot point, presenting identical resistance to airflow and operation in either direction through the damper (blades that are non-symmetrical relative to their axle
- f. Multiple section dampers must have factory installed jackshafts unless clearly eliminated by engineer.
 - g. Bearings shall be 304 stainless steel, oil impregnated, and self-lubricating sleeve type with a 450 pound (204 kg) minimum radial crush load. Bearings shall turn in extruded holes in the damper frame.
 - h. Axles shall be hexagonal positively locked into the damper blade.
 - i. Linkage shall be concealed out of airstream, within the damper frame to reduce pressure drop and noise.
 - j. Temperature limits shall be -72°(-58°C) to +275°F (+135°C).
 - k. Damper shall be tested and licensed in accordance with AMCA 511 for Air Performance and Air Leakage.
 - l. Damper widths from 12" to 60" (305 to 1524) wide shall not leak any greater than 3 cfm/sq.ft. at 1" w.g. (15.2 l/s-m2 at .25 kPa).

pivot point or utilize blade stops larger than 1/2 in. (13mm) are unacceptable); 1/2 in. (13mm) dia. plated steel axles turning in synthetic (acetal) sleeve bearings; TPE blade seals; flexible stainless steel jamb seals; and external (out of the airstream) blade-to-blade linkage.

7. [Outside air] [Return air] [Exhaust air] opening[s] shall be provided without a damper.]
- C. [Access section shall provide access between components shall be a minimum of [16" (406mm)] [24" (610mm)] [30" (762mm)] [36" (914mm)] [42" (1067mm)] [48" (1219mm)] [54" (1372mm)] deep. Access doors of galvanized steel for flush mounting, with gasket, latch and full size (minimum of 4.5") handle assembly. [Provide stainless steel drip pan in access section.] [Floor shall be lined with 0.125-inch aluminum tread plate to accommodate walk-in weight of service technician.]
- D. [Diffuser section shall be mounted on leaving side of supply fan section providing uniform air distribution across downstream components. Perforated diffuser plate shall be secured over blast area of fan to disperse airflow.]
- E. [Blender / air mixer section to provide proper air mixing and distribution of the outside and return airstreams. Proper spacing provided in the direction of airflow as recommended by the blender manufacturer (Blender Products or Kees).]
- F. [Sound attenuator section(s) shall be provided by the air handling unit manufacturer as an integral section of the unit to attenuate fan noise at the source. Provide acoustic performance and air pressure drop as scheduled. Silencer acoustic insulation shall be covered with perforated sheet metal. [Provide [mylar] [tedlar] [fiberglass cloth] liner between perforated sheet metal and acoustic insulation].
- G. [Manual section shall be provided by the air handling unit manufacturer as an integral section of the unit for field installation of special components. Section length to be determined by component supplier.]
- H. [[Inlet] [Discharge] plenum section shall be provided as the [first] [last] section in the direction of airflow. The plenum shall provide single or multiple [top] [end] [bottom] openings.]
- I. [Face and bypass section shall be provided to modulate airflow through and around heat transfer coils. Dampers shall be an integral part of the unit assembly. [Internal face and bypass shall be contained in the standard cabinet height] [External face and bypass arrangement shall be provided with factory provided bypass duct of same cabinet construction as the remainder of the unit. Field installed bypass ducts are not acceptable]. Blank-off and division sheets, internal linkage, access [panel] [doors] installed by unit manufacturer. Face and bypass dampers shall be of low leak design, opposed blade, with vinyl bulb edging and stainless steel edge seals, galvanized steel frame and axles in self-lubricating nylon bearings.]
- J. [Energy recovery wheel shall be constructed of corrugated synthetic fibrous media, with a desiccant intimately bound and uniformly and permanently dispersed throughout the matrix structure of the media. Rotors with desiccants coated bonded, or synthesized onto the media are not acceptable due to delaminating or erosion of the desiccant material. Media shall be synthetic to provide corrosion resistance and resistance against attack from laboratory chemicals present in pharmaceutical, hospital, etc. environments as well as attack from external outdoor air conditions. Coated aluminum is not acceptable. Face flatness of the wheel shall be maximized in order to minimize wear on inner seal surfaces and to minimize cross leakage. Rotor shall be constructed of alternating layers of flat and corrugated media. Wheel layers should be uniform in construction forming uniform aperture sizes for airflow. Wheel construction shall be fluted or formed honeycomb geometry so as to eliminate internal wheel bypass. Wheel layers that can be separated or spread apart by airflow are unacceptable due to the possibility of channeling and performance degradation. The minimum acceptable performance shall be as specified in the unit schedule.
 - a. Desiccant Material: The desiccant material shall be a molecular sieve, and specifically a 4A or smaller molecular sieve to minimize cross contamination.
 - b. Wheel Media Support System: The wheel frames shall consist of evenly spaced steel spokes, galvanized steel outer band and rigid center hub. The wheel construction should allow for post fabrication wheel alignment.
 - c. Wheel Seals: The wheel seals shall be full contact nylon brush seals or equivalent. Seals should be easily adjustable.
 - d. Wheel cassette: Cassettes shall be fabricated of heavy duty reinforced galvanized steel or welded structural box tubing. [Cassettes shall have a built in adjustable purge section minimizing cross contamination of supply air.] Bearings shall be inboard, zero maintenance, permanently sealed roller bearings, or alternatively, external flanged or pillow block bearings.
 - e. Drive systems shall consist of fractional horsepower AC drive motors with multi-link drive belts.
 - f. [Bypass dampers shall be furnished.]
 - g. Certification: The wheel shall be AHRI certified by the energy recovery wheel supplier to AHRI Standard 1060 and must bear the AHRI certification stamp. Private independent testing performed "in accordance with" various standards is not a substitute for AHRI certification and shall not be accepted. The wheel shall be listed or recognized by UL or equivalent.]
- H. [Energy recovery wheel heat exchanger shall be constructed of alternate layers of corrugated and flat aluminum sheet material. Both sides of the exchanger shall be completely smooth with less

then 0.005" variation between alternate layers to allow for optimum sealing surface for brush seals. The rotor shall have smooth air channels to ensure laminar airflow for low-pressure drops. Dry particles up to 900 microns shall pass freely through the rotor without clogging the media. The rotor media shall be capable of being cleaned with low temperature steam without degrading unit performance. The rotor media must be made of aluminum that is coated to prohibit corrosion. All surfaces shall be coated with a non-migrating absorbent specifically developed for the selective transfer of water vapor.

- a. Performance shall be as scheduled and verified by manufacturer. Assuming equal sensible and latent recovery effectiveness shall not derive performance.
- b. The rotor housing shall be constructed using a heavy-duty extruded and anodized aluminum tube frame (rotors less than 42" shall have a heavy duty galvanized frame without insulation) with double wall galvanized sheet metal panels with fiberglass insulation. Adjustable brush seals must be provided along the periphery of the rotor and between the inlet and outlet air passages to effectively prevent air leakage and cross-contamination between airflows. Total airflow between air streams from leakage and purge shall be less than 10% at 2.5"w.g. differential pressure between airflows. Rotor and casing shall be reinforced to prevent deflection from differential pressures to less than 0.03 inches. All rotors shall be mounted on sealed permanently lubricated spherical bearings. All rotors over 80" in diameter must have flanged or pillow block bearings that can be serviced or replaced without removal of the rotor from the case. [The unit must be provided with a factory set, field adjustable purge sector designed to limit cross contamination at qualified appropriate design conditions to less than 0.04 percent of the exhaust air stream concentration. Independent laboratory evaluations must indicate purge sector configurations, rotor construction, gasses, air pressure differentials, rotor speeds and other phenomena that constitute "appropriate design conditions" required to limit cross-contamination and air leakage.]
- c. The rotor drive system shall consist of a self-adjusting belt around the rotor perimeter driven by an AC motor with gear reduction. The variable speed drive shall be specifically designed for heat wheel applications and include: an AC inverter, soft start/stop, rotation detection w/alarm contacts, automatic self-cleaning jog cycle, and self testing capability. The speed controller shall be capable of accepting a potentiometer, VDC, or mA control signal.
- d. [The temperature control system shall consist of an integral control panel with remote temperature sensors mounted in each of the four air streams to monitor exchanger

performance. The control shall modulate rotor speed to (1) prevent frost build-up, (2) reduce heat recovery for economizer mode, and (3) switch to maximum heat recovery when outdoor temperature is higher than indoor temperature. A digital display keypad for monitoring temperatures and changing set points shall be included.]

- e. [Bypass dampers shall be furnished.]
- f. AHRI Certification: Sensible and latent recovery effectiveness must be clearly certified by the energy recovery wheel supplier through AHRI in accordance with AHRI Standard 1060.]

2.12 DAMPERS

- A. Damper Leakage: Leakage rate shall be less than two tenths of one percent leakage at 2 inches static pressure differential. Leakage rate tested in accordance with AMCA Standard 500.

PART 3: EXECUTION

3.01 INSTALLATION

- A. Install in accordance with manufacturer's Installation & Maintenance instructions.

3.02 ENVIRONMENTAL REQUIREMENTS

- A. Do not operate units for any purpose, temporary or permanent, until ductwork is clean, filters are in place, bearings lubricated, and fan has been test run under observation.

3.03 EXTRA MATERIALS

- A. Provide one set for each unit of fan belts and filters.



Daikin Applied Training and Development

Now that you have made an investment in modern, efficient Daikin equipment, its care should be a high priority. For training information on all Daikin HVAC products, please visit us at www.DaikinApplied.com and click on Training, or call 540-248-9646 and ask for the Training Department.

Warranty

All Daikin equipment is sold pursuant to its standard terms and conditions of sale, including Limited Product Warranty. Consult your local Daikin Applied Representative for warranty details. To find your local Daikin Applied Representative, go to www.DaikinApplied.com.

Aftermarket Services

To find your local parts office, visit www.DaikinApplied.com or call 800-37PARTS (800-377-2787). To find your local service office, visit www.DaikinApplied.com or call 800-432-1342.

This document contains the most current product information as of this printing. For the most up-to-date product information, please go to www.DaikinApplied.com.

Products manufactured in an ISO Certified Facility.