

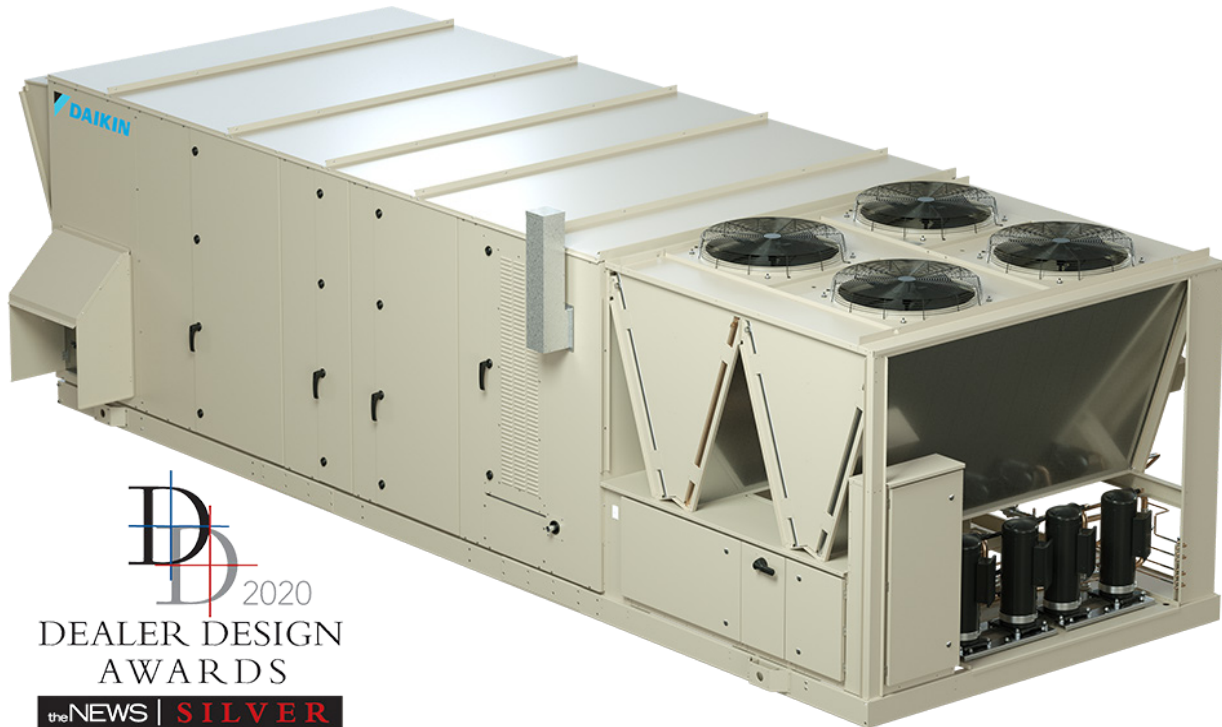

Catalog 258-1

## Rebel Applied™ Rooftop Systems

Heating and Cooling  
Models DPSA/DFSA  
30 to 52 Tons  
R-410A Refrigerant



|   |           |   |           |
|---|-----------|---|-----------|
| <b>Introduction</b> .....                       | <b>3</b>  | <b>Efficiency Ratings</b> .....         | <b>23</b> |
| Nomenclature .....                              | 3         | <b>Example Layouts</b> .....            | <b>24</b> |
| Maximum Performance .....                       | 4         | <b>Service Clearance</b> .....          | <b>27</b> |
| Configured Solutions .....                      | 5         | <b>Curb Drawings</b> .....              | <b>28</b> |
| Reduced Operating Costs .....                   | 6         | <b>Application Considerations</b> ..... | <b>29</b> |
| Features and Options .....                      | 7         | General .....                           | 29        |
| <b>Cabinet Construction</b> .....               | <b>8</b>  | Unit Location .....                     | 29        |
| Construction .....                              | 8         | Service Clearances .....                | 29        |
| Air Leakage and Thermal Performance .....       | 8         | Operating Range .....                   | 29        |
| Serviceability and Access .....                 | 9         | Acoustics .....                         | 30        |
| <b>Refrigeration</b> .....                      | <b>10</b> | Ductwork Considerations .....           | 30        |
| Condenser .....                                 | 10        | <b>General Specification</b> .....      | <b>31</b> |
| Energy Efficiency .....                         | 10        |   |           |
| Quiet Condensing Operation .....                | 10        |   |           |
| Low Ambient Operation .....                     | 10        |   |           |
| Enhanced Serviceability .....                   | 10        |   |           |
| <b>Ventilation and Indoor Air Quality</b> ..... | <b>11</b> |   |           |
| Outside Air Control .....                       | 11        |   |           |
| Sorbent Ventilation Technology .....            | 11        |   |           |
| Filtration .....                                | 11        |   |           |
| Energy Recovery .....                           | 12        |   |           |
| <b>Heating</b> .....                            | <b>13</b> |   |           |
| Gas Heat .....                                  | 13        |   |           |
| Electric Heat .....                             | 13        |   |           |
| Hot Water and Steam Heat .....                  | 13        |   |           |
| <b>Fans</b> .....                               | <b>14</b> |   |           |
| Supply, Return, and Exhaust Fan Array .....     | 14        |   |           |
| EC Motor Technology .....                       | 14        |   |           |
| Sound .....                                     | 15        |   |           |
| Electrical .....                                | 15        |   |           |
| <b>Configurability</b> .....                    | <b>16</b> |   |           |
| Air Blenders .....                              | 16        |   |           |
| Sound Attenuators .....                         | 16        |   |           |
| Humidifiers .....                               | 17        |   |           |
| UV Lights .....                                 | 17        |   |           |
| <b>Controls</b> .....                           | <b>18</b> |   |           |
| <b>Operations</b> .....                         | <b>19</b> |   |           |
| General .....                                   | 19        |   |           |
| Building Pressure Control .....                 | 19        |   |           |
| Energy Recovery .....                           | 19        |   |           |
| Physical Data .....                             | 20        |   |           |
| Heating Data .....                              | 22        |   |           |

# Rebel Applied: Rising Above Packaged Rooftop Systems to Provide a New Standard in Configurable Rooftop Solutions

- 30-52 tons with the flexibility to serve 100% outdoor air, dehumidification, and VAV applications
- Thermally broken, double wall foam construction with R-13 thermal resistance and rigid full length piano hinged doors.
- Ultra-low air leakage cabinet construction with leakage rates less than 0.5% of design CFM up to 5" Static Pressure and less than 1% of design CFM up to 8" of static pressure.
- ECM fan array technology provides redundancy, efficiency and low sound
- Adaptive cabinet design features customized layouts for each unique application.
- At a minimum, product performance exceeds Department of Energy 2023 efficiency requirements
- High Efficiency options provide EER's over 11.0 and IEER's up to 17.2.
- Precision heating and cooling temperature and humidity control with modulating technologies that provide superior turndown.
- Airflow measuring, Filtration, UV lights, and ventilation controls for optimized Indoor Air Quality
- Fully tested, Factory commissioned job site specific control set points
- Quiet operation is standard, with options to tailor radiated and ducted sound performance to each application.

## Nomenclature

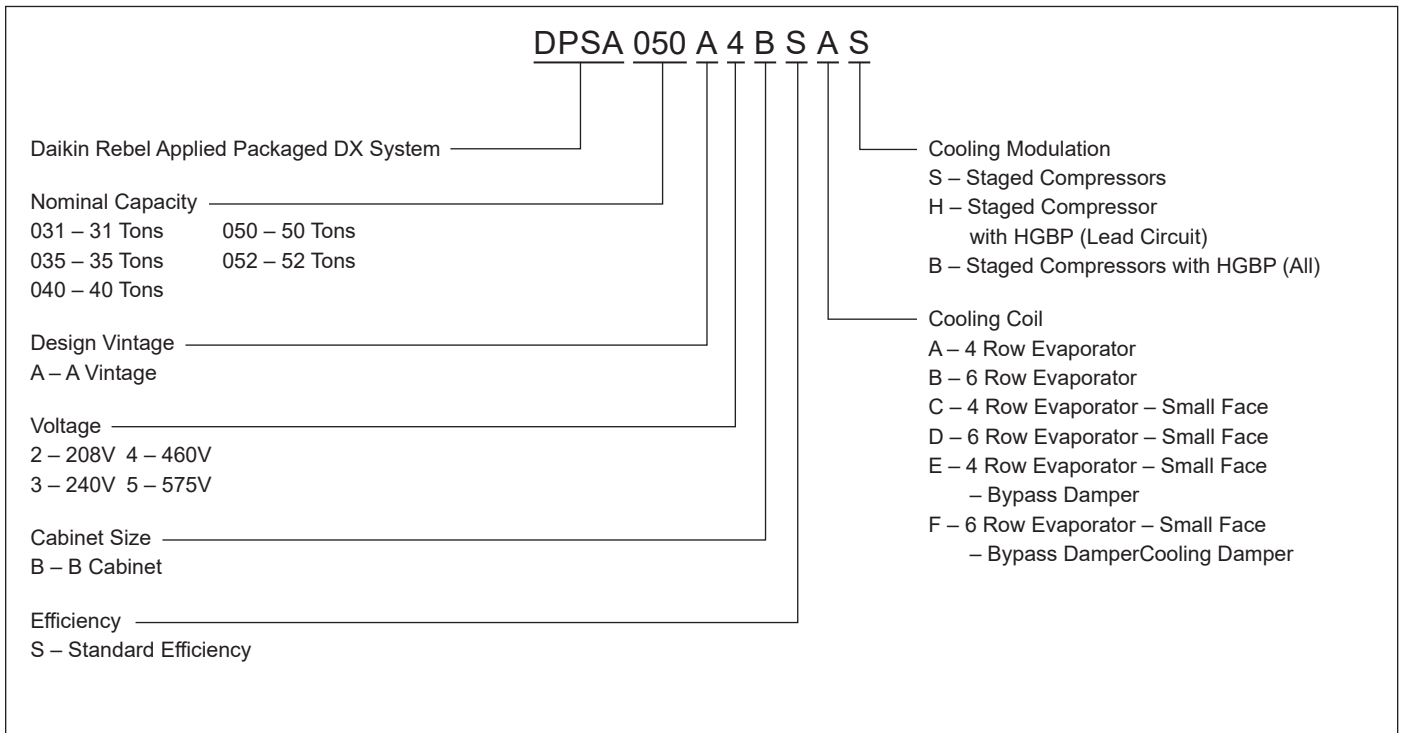

Daikin Rebel Applied rooftop systems bring the latest in high quality, high performance technology to the applied rooftop market. Rebel Applied rooftop systems are built to perform, with features that provide lower installed costs, high energy efficiency, superior indoor air quality, and quiet operation. low cost of maintenance and service, and industry leading longevity.

**Figure 1: Rebel Applied Cutaway**

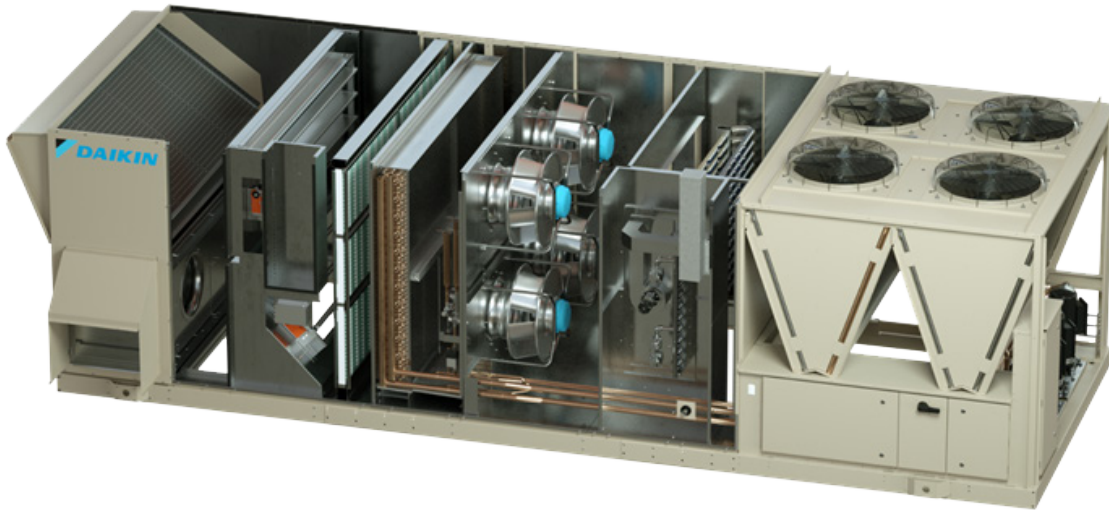

## Maximum Performance

### Unrivaled Construction

Unrivaled construction performance with thermally broken, gasketed, double foam injected panels that increase thermal performance, reduce air leakage and enhance indoor air quality. Cabinet Performance Savings range from \$200-\$1000 per year in saved operating costs.

### Increased Thermal Performance

The panel design is engineered to provide a thermally broken construction that eliminates all uninsulated direct conduction paths between the indoor and outdoor environments resulting in superior thermal performance. 2" thick double wall foam injected panels with a thermal resistance of R-13 provides efficient thermal insulation and no exposed insulation for high indoor air quality.

### Low Air Leakage Construction

Air leakage occurs as infiltration or exfiltration. Infiltration occurs when negative sections draw air in resulting in unconditioned and unfiltered air to enter the unit and be supplied to the building. Exfiltration occurs when positive sections leak air out. Air that has already been invested in for filtration and conditioning is lost and is not supplied to the building. The low air leakage construction of the Rebel Applied prevents costly energy from being wasted and poor indoor air quality by ensuring the air delivered to the space is conditioned and filtered. Rebel Applied's Ultra-low air leakage cabinet construction provides air leakage rates less than 0.5% of design CFM up to 5" of Static pressure and less than 1% of design CFM up to 8" of static pressure.

### Energy Efficiency

Energy efficiency is a standard feature in the Rebel Applied rooftop with high efficiency direct-drive ECM fans and scroll compressors. Every model offers additional efficiency with optional energy recovery, high efficiency 6 row cooling coils, Daikin compressor technology and fully modulating condenser fans. All models using variable speed inverter compressors exceed the Department of Energy Minimums for the year 2023 by 50% and qualify for utility rebates.

## Configured Solutions

Rebel Applied provides an adaptive cabinet design that gives HVAC system designers flexibility to configure solutions unique to each customer to better serve better solutions for applications that require greater indoor air quality (IAQ), energy efficiency, control and redundancy.

### Engineered Flexibility

Rebel Applied is designed to provide engineered cabinet flexibility to give HVAC system designers the flexibility to minimize footprint, and configure equipment solutions unique to each customer.

### Footprint

Up to 40% shorter and 30% lighter than legacy rooftops, Rebel Applied is easier to install. Configurable construction in 4" increments of length lowers replacement costs by eliminating large transition curbs and simplifying the installation process.

### Airflow Flexibility

Rebel Applied makes designing mechanical systems easier by offering airflow configurations for horizontal supply and return duct connections

### Application Layout

Configure the airflow path to meet building requirements in healthcare, industrial, education and office applications. Air path flexibility gives designs flexibility to configure solutions unique to each customer to better serve applications that require greater indoor air quality, energy efficiency and redundancy.

- Energy recovery
- Sorbent ventilation
- Shipping splits
- UV lights
- Extra access sections
- Chilled water
- Hot water/steam sections
- Sound attenuators
- Air blenders
- Humidifier grids
- Final filtration sections
- Fan array backdraft dampers
- Out of air-stream vestibules

### Indoor Air Quality

Filtration, temperature, humidity control, and sound are all important considerations when designing HVAC systems for indoor air quality. The configurability of Rebel Applied helps design indoor air quality solutions by providing flexible air handling options for filtration, humidification and sound attenuation.

- *Filtration:* Rebel Applied has flexible filtration options to satisfy indoor air requirements from varying space types.
  - *Pleated Filter Options:* MERV 8 or 13 Filtration efficiencies in 2" or 4" filters exceed the AHSRAE 62 minimum MERV 6 required to keep the HVAC equipment clean and operating efficiently.
  - *Rigid Cartridge Filters:* 98% of the particulate count in outside air is less than 0.5  $\mu\text{m}$ . For adequate filtration of these particles a MERV 13 or higher filter is required. MERV 14 Cartridge filters are 75-85% efficient in 0.3-1  $\mu\text{m}$  particle size and offer a longer filter life than pleated MERV 13 filters. Rebel Applied is available of MERV 11, 14, 16 Filtration in the draw-through or final position
  - *HEPA Filtration:* 99.97% efficient particle capture; these filters are used for life-safety protection in critical care applications like hospitals and clinics.
  - *Carbon or Gas Phase Filtration:* Rebel Applied can be supplied with other filter media to help with applications in contaminated ventilation air environments like air ports or in spaces where odors may need to be filtered out of the supply air
- *Temperature Control:* Rebel Applied can be configured for varying levels of temperature and humidity control in both heating and cooling operating ranging from staged capacity control to fully modulating capacity control designed to provide +/-1°F supply air temperature control.
- *Dehumidification/Humidification:* Indoor humidity control is a critical component for occupant health. High humidity supports dust mites and allergies and can result in material degradation and mold. Low humidity dries out mucous membranes in humans which increased risk of illness.
- *Acoustics:* Daikin Rebel Applied rooftops offer fan and air handling configurability to optimize sound for each application. Perforated Liners and factory mount sound attenuators provide single source solution to meet space sound requirements

### Direct Replacement

Configurable Cabinetry makes it easy to design your Rebel Applied rooftop to fit to an existing Trane® Intellipak® or Daikin RoofPak® curb without requiring expensive adapter curbs or prolonged downtime during replacement.

## Reduced Operating Costs

Proven Daikin rooftop energy efficiency and quality combines with easy-to-maintain features to make the Rebel Applied a cost-effective, durable rooftop solution.

### Native Intelligence

Reduced operating costs start with smart controls, performance analytics and easy to maintain features.

- **Pre-commissioned:** Installers save time commissioning equipment when they choose Rebel Applied with preloaded jobsite specific controls set points and configurations.
- **Refrigeration Monitoring:** Optional refrigeration sensors enable quick direct digital measurement of the performance of the refrigeration cycle. This enhances serviceability with real time discharge, liquid and suction refrigeration conditions with calculated subcool performance at the unit controller. These sensors also enable a condenser service status to indicate coil cleaning is needed or a condenser fan failure may be present. Additionally this provides a low charge alarm to indicate a leak or system maintenance may be required.
- **Direct-dive ECM Fan Arrays:** Direct-dive ECM fans provide redundancy and operating feedback to the controller to announce alarms when motor replacement is required.
- **SiteLine™ Building Controls:** Monitor, and troubleshoot equipment remotely with SiteLine and leverage local control features like airflow measuring on all fans, real time electronic filter pressure transducer monitoring and compressor envelope protection to prevent failures and prolong equipment life.

### Making Maintenance Easier

Operating expenses go way beyond energy consumption; To optimize the lifecycle cost of Rebel Applied rooftops we designed in features that make it easier to service, saving time and money for building owners and operators.

- **Direct-dive ECM Fan Arrays:** ECM Fans reduce the start-up process by eliminating belts, and sheaves that have to be adjusted at start up and eliminates shipping blocks. Direct-dive ECM fans also offer a low maintenance cost by eliminating belt maintenance activities such as tensioning and replacement, sheave alignment, or fan bearings lubrication service. Since Rebel Applied uses direct-drive ECM fans for all supply, return and exhaust fans, annual service is reduced by at least 2 hours of service time per unit per year. Additionally, all ECM fan arrays are provided with quick connect wiring that is easy to disconnect and only 4 bolts for mounting which simplifies and saves time in the event of replacement.
- **Refrigeration Options:** Rebel Applied comes with an optional refrigeration maintenance package that reduces cost throughout the life of the unit. Compressor isolation valve and replaceable core filter a dryer reduces pump down, and service time for providers. Refrigeration monitoring systems allow quick measurement of the superheat and subcool performance, low charge indication, and condenser service status through the unit controller which saves time on troubleshooting and service calls.
- **Gas Heat Controls:** Rebel Applied Gas Heat Units provide furnace controller alarm feedback to the unit controller and building automation system so alarms can be identified quickly to expedite service.

## Features and Options

### Standard Features

- High Efficiency Inverter compressor on lead refrigeration circuit
- Premium Efficiency Inverter compressors on all refrigeration circuits
- Double-wall foam-injected panel with thermal resistance of R-13
- Integral thermal break in all walls, doors, floors and roof panels
- Low air leakage: <0.5% air leakage at +/- 5 in w.c. of static pressure; CL6 @ 6 in w.c. per ASHRAE Std 111
- Pre-paint exterior surfaces withstand a minimum 3000 hr salt spray test per ASTM B117
- Access doors are mounted with durable full length stainless steel piano style hinge
- A single, lockable handle and latch mechanism plus door holders on each access door
- Dual refrigeration circuits with fully interlaced evaporator coils
- Minimum operating ambient down to 50°F mechanical cooling
- A minimum of four stages of compressor capacity control for stable discharge air temperature and humidity control
- A minimum of (2) direct-drive ECM supply fans to offer redundancy, reduced maintenance, and higher efficiency
- 2" MERV 8 filtration with dirty filter monitoring
- Multi-stage gas heat with 439 stainless steel heat exchanger
- Multi-staged electric heat
- Hot water or steam heat
- Standard 1 year parts, labor and compressor warranty
- Standard 10 year gas heat exchanger warranty
- Separated high and low voltage control panels for safe access to human control interfaces
- 208V/230V/460V/575V
- Single point power block connection
- 10 KAIC SCCR
- Phase voltage monitor
- MicroTech® 4 controls

### Customizable Features

- Factory installed insulated or uninsulated Humidifier Grid with stainless steel drain pan with wetting distances from 15" to 36"
- Fixed blade position air blender to promote the best mixing of outdoor and return air
- Utility out of airstream vestibule section with optional floor supports for field mounted humidifier generators and floor treadplate for user safety
- Sorbent Ventilation Module to increase indoor air quality.
- 100% or 0–30% outside air damper or 0-100%

economizer damper

- Low static exhaust or high static exhaust or return fans
- Energy efficiency (coil face area, 6 row coils)
- Modulating hot gas reheat for dehumidification
- Low ambient mechanical cooling
- Quiet condensing and compressor sound blankets
- Speedtrol®, modulating head pressure control
- Outdoor and fan airflow measuring
- Refrigerant system monitoring (liquid, suction, and condensing refrigerant pressure/temperature sensors)
- Modulating gas heat control between 5:1 and 100:1 turndown
- Modulating hot water and steam control valves
- ECM supply fan array with backdraft dampers for redundancy
- Extended 5 year parts, labor and compressor warranty
- Extended 20 year heat exchanger warranty
- 2"/4" filter rack with Merv 8 or 13 filters
- 2" Merv 8 pre-filter with 12" rigid cartridge Merv 11, 14, 16, or carbon filters
- Final filters – 12" rigid cartridge MERV 14, 16, HEPA
- Non-fused, unit mounted disconnect switch
- Dual point power for back-up power systems
- 115V service outlet
- 65 KAIC electrical rating
- Line reactor, power factor correction
- MicroTech 4 controls with BAS integration and power measuring

### Replacement Capabilities

The Rebel Applied product has been designed to be able to fit to existing curbs of other Daikin or Trane packaged equipment of similar nominal tonnage size. Contact sales support for specific model/size/matches.

#### Supports Trane configurations:

- Gas Heat
- Hot Water Heat
- Steam Heat
- Extended cabinet
- Economizer (with or without fans)
- 0 degree ambient cooling

#### Supports Daikin RoofPak® configurations:

- Gas Heat
- Hot Water Heat
- Steam Heat
- Electric Heat
- Economizer (with or without fans)
- 0 degree ambient cooling

## Construction

Rebel Applied rooftop systems introduce rooftop market in cabinet construction by providing.

- Nominal unit cooling capacities from 30 to 52 tons
- Pre-painted exterior surfaces that withstand a minimum 3000 hour salt spray test per ASTM B117 to provide longevity and prevent excessive corrosion
- Double-wall foam injected panel construction for all cabinet walls, access doors, and roof and floor panels with solid steel liners and a thermal resistance of R-13
- All Access doors are mounted with a durable full length stainless steel piano style hinge

Figure 2: Rebel Applied Door – Exterior View



Figure 3: Rebel Applied Door – Construction



## Air Leakage and Thermal Performance

All panels are constructed with an integral thermal break to eliminate all direct conductive heat transfer paths through the panel which prevents energy losses and exterior condensation.

Through metal provides a path for heat to enter the cabinet and lowers the effective R-value of the insulation. Figure 2 shows a foam panel with R-8 insulation and 1% through metal performs like an R-6 thermally broken panel.

Figure 4: Thermal Break

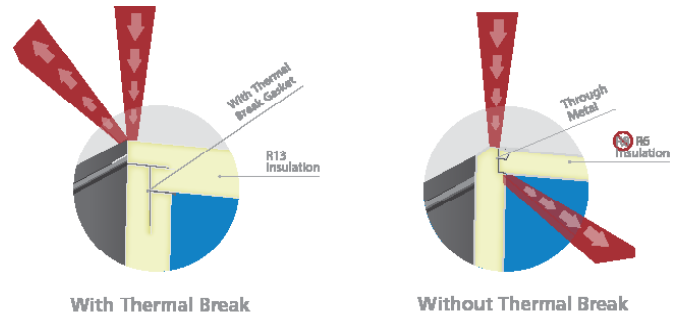

Rebel Applied offers the industry's first low leakage packaged rooftop cabinet and is tested in accordance with ASHRAE Standard 111 with a rating of Class 6 air leakage at +/- 5" of static pressure or 0.5% of supply air flow up 5" of static pressure. Most new applied rooftop equipment operates with leakage rates >3% at 5" of static pressure; Aging applied systems leakage can approach leakage rates as high as 5-10% of the supply cfm. Light commercial rooftops typically operating at lower pressures (3" or less) and see air leakage rates in excess of 5% in most applications.

Figure 5: Rebel Applied Air Leakage Rates

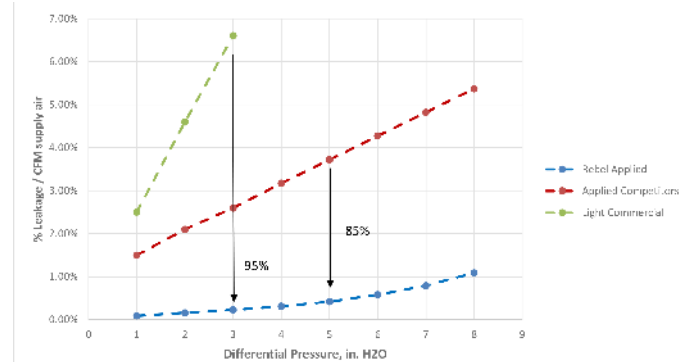

NOTE: These leak rates are based on a 50 ton unit at 350 cfm/ton with economizer and gas heat



A word on air leakage: Air leakage represents a substantial operating cost for equipment operators. Leakage occurs in rooftop equipment in the form of infiltration, negative sections drawing air in, and exfiltration, positive sections leaking air out. Both forms of leakage waste energy. Excessive infiltration results in unconditioned and unfiltered air being supplied to the building. Excessive exfiltration is when air that has already been invested in for filtration and conditioning is lost and not supplied to the building. In both cases, additional conditioning above the building loads is required meaning additional operating load and additional operating expense. Figure 6 shows the average annual operating cost to building operators due to thermal losses and air leakage by city. Leakage costs an average of \$600 per year in additional operating expenses and more in high load climates.

Rebel Applied's low leakage thermally broken casing saves building operators 90% of the thermal and air leakage costs (Figure 7).

**Figure 6: Average Annual Operating Costs of Thermal Losses and Leakage**

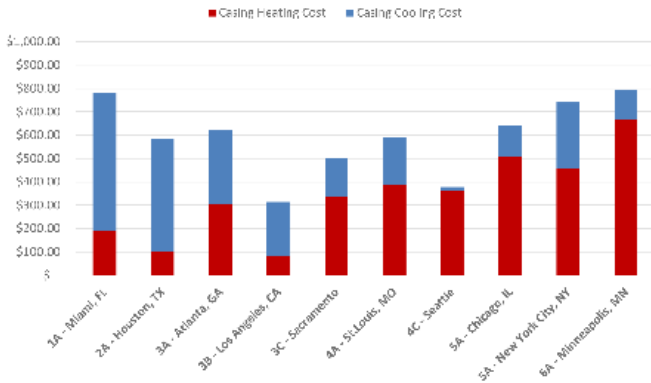

**Figure 7: Rebel Applied Low Leakage Casing Savings**



## Serviceability and Access

- Access doors are provided on all critical maintenance sections to provide easy access to components
- A single, lockable handle and latch mechanism plus door holders on each access door

**Figure 8: Door Levers**



## Condenser

- All units feature dual refrigeration circuit design with fully interlaced evaporator circuits for redundancy and efficient part load control
- A minimum of four stages of compressor capacity control and optional hot gas bypass (on one or both circuits) provides for stable discharge temperature and humidity control

### Fully Modulating Hot Gas Reheat with Two Point Dehumidification Control

Hot refrigerant gas leaving the compressor can be directed to a separate coil to reheat the cold, dehumidified air leaving the cooling coil. This reheat costs no energy and is an excellent way to precisely control and optimize dehumidification.

To provide optimized dehumidification control the Rebel Applied dehumidification sequence controls the compressors capacity by using direct feedback of the temperature leaving the evaporator coil. This temperature is at a saturated coil condition and is effectively the dewpoint that is being supplied to the space. Directly controlling dewpoint provides users with the flexibility to commission the equipment to provide the dehumidification each application requires; No more, no less. The fully modulating hot gas reheat coil is controlled independent of the compressors to maintain constant supply air temperatures which is critical to prevent over-cooling and poor space control during dehumidification operation.

### Modulating Liquid Subcool Reheat

To achieve precise humidity and temperature control in applications that require constant dehumidification reheat the use of a liquid subcool coil can increase energy efficiency. By sending warm liquid refrigerant from the condenser to a reheat coil in the airstream the unit recovers waste heat resulting in free reheat and extra subcooling. This provides an additional 10-20% capacity per nominal ton and constant dehumidification. The liquid subcool coil will work in tandem with the modulating hot gas reheat coil to achieve best in class humidity and temperature control with added energy efficiency.

## Energy Efficiency

- Industry leading energy efficiency customizable for any application
- Select between two coil areas with 4 or 6 rows to optimize energy efficiency to maximize rebates
- Select between Daikin Fantrol, staged control, or Speetrol, modulating condenser fan, control to meet customer efficiency needs
- Inverter compressor on the lead refrigeration circuit will provide **high energy efficiency** that will achieve **up to 18 IEER**
- Inverter compressors on all refrigeration circuits will provide a best in class **premium energy efficiency** that will achieve **up to 20 IEER**

Figure 9: Rebel Applied Qualifying Rebates

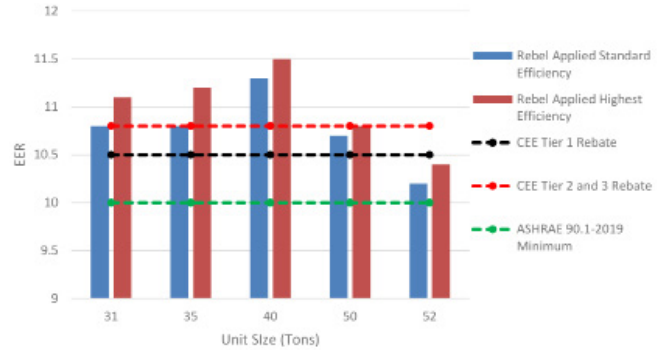
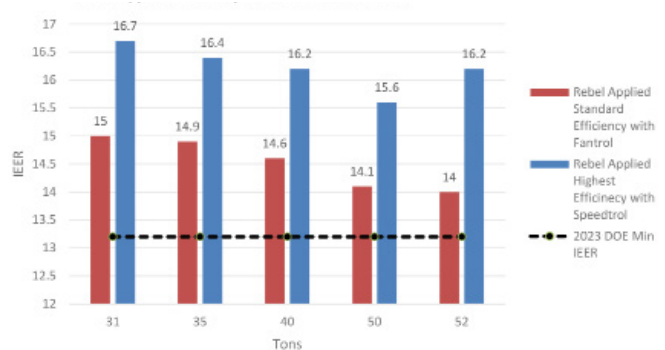

Figure 10: Rebel Applied Exceeds 2023 Efficiency Minimums



## Quiet Condensing Operation

Specially engineered quiet condenser design to reduce radiated noise by an average of 10 dBA or more compared to standard units.

## Low Ambient Operation

Minimum Operating Ambient down to 50°F Mechanical Cooling is included as standard. Optional fully modulating Low ambient head pressure control allows mechanical cooling down to -10°F ambient conditions.

## Enhanced Serviceability

Optional Compressor Isolation Valves, Replacable Core Filter Driers, and Refrigeration Monitoring sensors enhance the serviceability and longevity of rooftop systems.

## Outside Air Control

- Outside air intake hood constructed from painted galvanized steel for longer equipment life with moisture eliminator filters to prevent water from entering the unit promoting better IAQ
- Low Leak Dampers with 1.5 cm per square foot at 1" pressure
- Factory installed thermal dispersion Ebtron outdoor airflow measuring stations, independently calibrated using NIST traceable standards to control ventilation with an accuracy of +/- 5% at occupied ventilation rates

Figure 11: Rebel Applied Outside Air Control



## Sorbent Ventilation Technology

- Sorbent filtration absorbs pollutants allowing oxygen and water to pass freely
- 1 or 2 modules option
- Can reduce volume of total outdoor air needed

Figure 12: Sorbent Ventilation Section

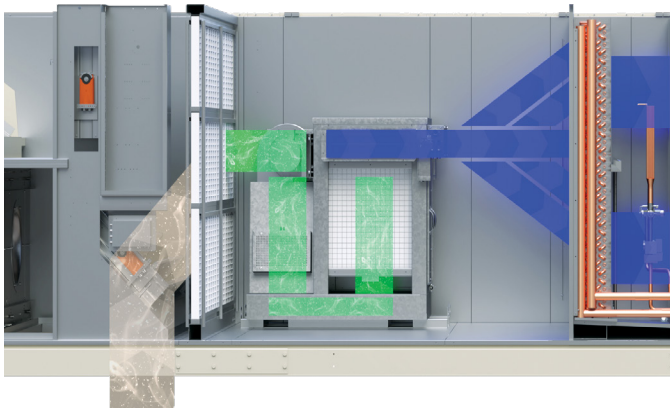

## Filtration

- Standard draw-through filter section and an optional final filter section with dirty filter alarm
- An optional electronic pressure transducer measures dirty filter status and can be monitored through the unit controller or building automation system in accordance with ASHRAE Standard 170 for Ventilation of Healthcare Facilities
- An optional Magnahelic® pressure gauge is available on each filter rack
- Draw-through filter options:
  - 2" MERV 8
  - 2" MERV 8 + 4" MERV 13
  - 2" MERV 8 and a 4" MERV 15 cartridge filter
  - 2" MERV 8 and a 12" MERV 11, or 14,16 and carbon cartridge filters
- Blow-through Final Filter Options:
  - 12" MERV 14 cartridge filter – side load
  - 97% efficient BioCell MERV 16 – face load
  - 99.9% efficient HEPA filter – face load
- Special filters available upon request

Figure 13: Face Load Filters

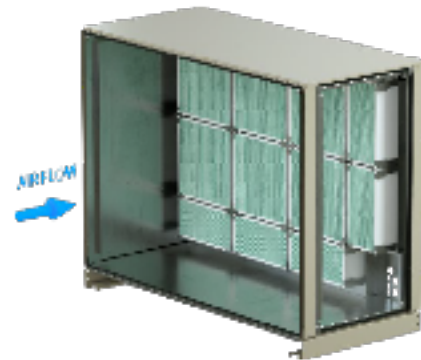

## Energy Recovery

- Daikin offers fully integrated energy recovery options to meet ASHRAE 90.1 requirements for energy recovery
- Integral energy recovery wheels recover 50+% of both sensible and latent energy from waste air
- Aluminum substrate with 3 angstrom desiccant
- Single point power with integrated defrost and capacity controls
- Defrost options for variable speed defrost control and electric preheat defrost
- 4" MERV 8 high capacity energy recovery filtration for high holding capacity to extend filter life in the outdoor air energy recovery path
- Energy recovery wheel filters include dirty filter alarm to alert filter replacement
- Wheel rotation detection is standard on all energy recovery wheels applications so maintenance can be performed as soon as it is required
- Slide out wheel cassette & track for easy maintenance and cleaning
- Unitary design for installation and rigging cost savings

Figure 14: Energy Recovery

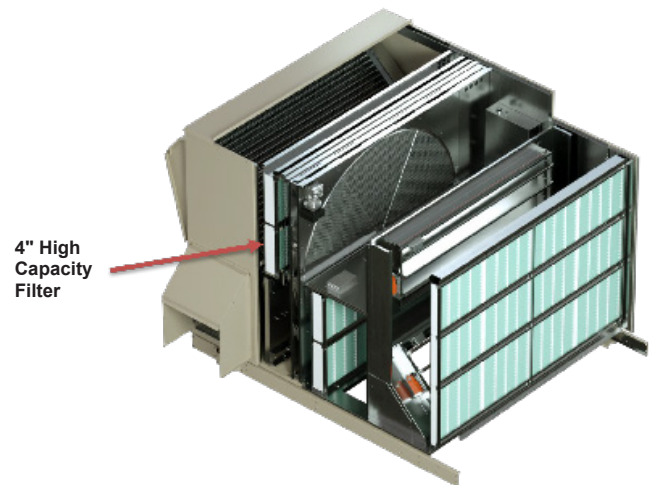

## Gas Heat

Extensive selection flexibility from 200 to 1,125 MBh input can satisfy wide ranging needs. Staged control, low modulating (5-10:1), high modulating (10-20:1) and 100:1 modulating control with SCR Preheat provides the flexibility to solve diverse needs

- Gas furnace assemblies are ETL or ETL-Canada listed
- All burner assemblies are factory tested and adjusted prior to shipment
- Air temperature rise capability of up to 100°F on most models
- 439 stainless steel heat exchangers provide long life in 100% outside air applications
- Fuel connections are pre-piped to the exterior for simplified install with no internal unit field connections required
- Heating control fully integrated into the unit's MicroTech 4 control system

### SuperMod® 100:1 High Turndown Gas Burner with Preheater

- Full turndown with continuous modulation between 1% and 100% of rated capacity provides precise temperature control for a comfortable tenant environment, even during shoulder seasons and in demanding applications such as, 100% make-up air and VAV systems
- Solves the mixed air tempering requirements of VAV systems when meeting ASHRAE 62.1 ventilation requirements at cold ambient, light load conditions
- Operates at normal inlet gas pressures, throughout the entire modulation range
- 5 burner sizes ranging from 200 MBh to 1,125 MBh input capacity

**Figure 15: Gas Furnace**

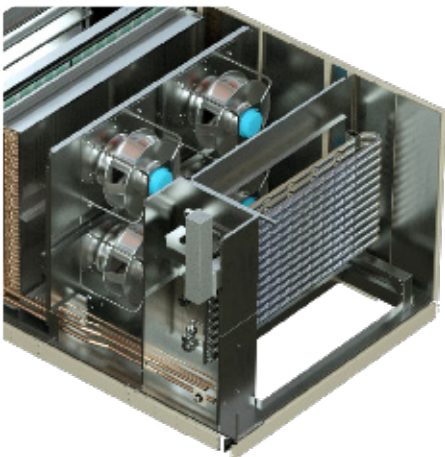

## Electric Heat

- 20 kW to 230 kW selections factory installed and tested
- Multi-stage or SCR control capability for application flexibility
- Durable low watt density, nickel chromium elements for longer life

## Hot Water and Steam Heat

- Steam heating coils are 1-row or 2-row, 5/8-in. O.D. copper tube/aluminum fin jet distributing type with patented HI-F5 fin design
- Multiple coil selections offered to size heating output to application needs
- Heating control fully integrated into the unit's MicroTech 4 control system
- Factory-installed two or three-way modulating control valve, piping and modulating spring return actuator provide system control and full flow through the coil in the event of a power failure
- Available with factory-mounted freeze-stat

**Figure 16: Hot Water or Steam Coil**



## Supply, Return, and Exhaust Fan Array

- Single Width, Single Inlet (SWSI) Class II Construction supply fans with aluminum blades provide efficient and quiet operation at a wide range of static pressures and airflow requirements
- Rebel Applied offers Direct-drive ECM Fans configured in multiple array configurations to provide industry leading application optimization
- Fans are statically and dynamically balanced in two planes as per DIN/ISO 1940 to balancing grade G 6.3; Stringent factory balancing, and no belts eliminates the need for spring isolation on fans

Figure 17: Supply Fan Array



Figure 18: Exhaust Fan Array



Figure 19: Return Fan Array



## EC Motor Technology

- Electrically commutated motors (ECM) consist of a variable speed permanent magnet brushless DC motor with an integral inverter. The integral inverter eliminates variable frequency drives (VFD) saving energy losses, and enhancing energy efficiency at part load
- ECM Fans provide the highest efficiency under modulation of any fan solution available today
- ECM motors offer built in phase failure protection, power factor correction to a minimum of 0.95, EMI and RFI protection and soft start
- No slip losses in the rotor like VFD and induction motor systems provide the high efficiency achievable at part load
- All motors are totally enclosed and are constructed to meet IP54 enclosures to protect against circulating dirt, dust, and seepage of water, and oil
- All fans are offered with totally enclosed, no maintenance bearings with application rated L50 = 350,000 hr bearing life or more; equal to 40 years of 24/7/365 operation
- Direct drive motors offer the lowest total operating cost because they require no field maintenance. The direct-drive design means there is no need to maintain belts, pulleys, bearings or drives

## Redundancy

- The Rebel Applied fan array can be sized to offer redundant operation in the event of a fan failure
- Each fan communicates via Modbus® and speed, and alarm are reported through the MicroTech 4 controller. In the event of a fan failure, the other fans can be sped up to keep the rooftop unit operational
- Optional backdraft dampers are available on the supply fan array to prevent recirculation during a fan failure

**Figure 20: ECM Fan Array with Backdraft Dampers**



**Figure 21: Backdraft Dampers**



## Sound

- EC plenum fans offer industry leading quiet operation
- Rebel Applied fan array configurability allows for sound application optimization

## Electrical

- High and low voltage wiring separated in the main control panel and throughout the unit
- Units are completely wired and tested at the factory, with control wiring routed in an accessible, protective wire raceway at the base of the unit
- Wiring complies with NEC requirements and all applicable UL standards
- For ease of use, wiring and electrical components are number coded and labeled according to the electrical diagram
- Units have an optional 115V convenience receptacle
- Supply and return air fan motors, compressor motors, and condenser fan motor branch circuits have individual short circuit protection
- All units are provide with a single point power connection with a power block or disconnect switch
- A unit-mounted disconnect includes a service handle on the exterior of the control panel door
- Electrical power feeds inside the perimeter roof curb through factory provided knockouts in the bottom of the main control panel
- Dual disconnects are available to satisfy emergency power requirements. Supply and return fan motors and controls are on the emergency power circuit and the balance of the unit is on the other
- Phase-failure/under-voltage protection is available to protect equipment function from abnormal power conditions
- Standard unit SCCR (Short Circuit Current Rating) is 10 KAIC and high SCCR protection is available up to 65 KAIC

Rebel Applied rises above traditional rooftops with unprecedented configurability. Its adaptive cabinet design gives engineers flexibility to configure a solution unique to each customer and better serve applications with needs for greater indoor air quality, energy efficiency, and redundancy. In its base format, Rebel applied is up to 40% shorter and 30% lighter than legacy rooftops making Rebel Applied is easier to install. Configurable construction in 4" increments of length lowers replacement costs by eliminating large transition curbs and simplifying the installation process.

## Replacements

- Configurable construction in increments of 4" of length makes matching old rooftop footprints and eliminates or minimizes large transition curbs
- Baserailed curb pockets configurability makes direct replacement of multiple manufacturers legacy rooftops. Daikin RoofPak and Trane IntelliPak can be replaced directly and others with minimal transitions

## Access Sections

- Add Blank or Access sections to customize serviceability
- Vary unit length and Layout to meet any application

## Air Blenders

- Factory installed between the outside/return air section and the filter section
- Provides blended air temperatures to minimize the potential for freeze/heat trips when using a hydronic heating source
- Blended outside/return air streams improve system control and avoid uneven temperature distribution at the duct take-offs

## Sound Attenuators

- Factory-installed downstream of the supply fan to dampen fan noise in sound sensitive applications
- Several factory selected sound attenuator options designed for varying levels of sound reduction, and unit footprints
- Can reduce sound levels by as much as half in the lower octave bands and more than half in the higher octave bands



## Humidifiers

- Factory installed steam humidifier distribution grids downstream of the supply air fan
- Insulated and Non-insulated grids selectable to meet most application humidification requirements
- Optimized Dispersion Lengths of 15", 24", and 36" lengths
- Out of Air stream section for field mounting of steam generator

**Figure 22: Rebel Applied Humidifier Section**

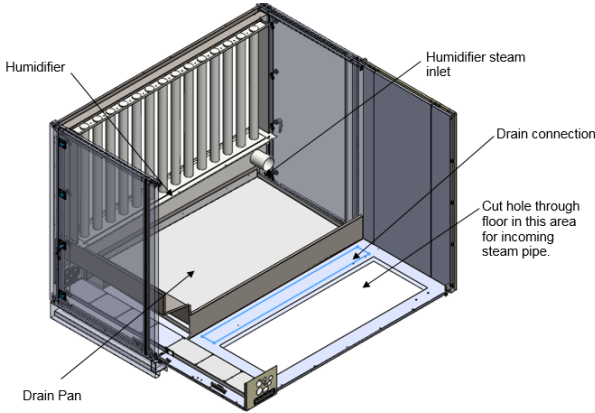

## Modulating Liquid Subcool Reheat

To achieve precise humidity and temperature control in applications that require constant dehumidification reheat the use of a liquid subcool coil can increase energy efficiency. By sending warm liquid refrigerant from the condenser to a reheat coil in the airstream the unit recovers waste heat resulting in free reheat and extra subcooling. This provides an additional 10-20% capacity per nominal ton and constant dehumidification. The liquid subcool coil will work in tandem with the modulating hot gas reheat coil to achieve best in class humidity and temperature control with added energy efficiency.

**Figure 23: Modulating Liquid Subcool Reheat Section**

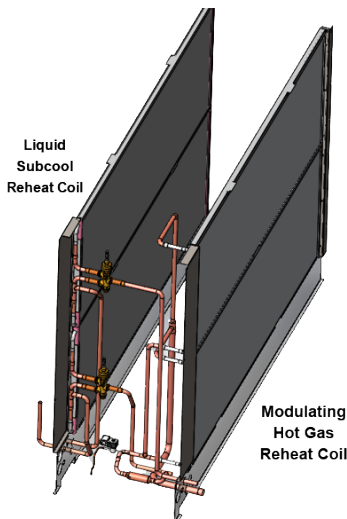

## UV Lights

- Factory-installed ultraviolet lights are available on the downstream side of all cooling coils and above the unit drain pan.
- All ultraviolet lights are pre-engineered and factory installed for ease of use and proper placement for maximum effectiveness. The ultraviolet lamps irradiate the coil and drain pan surfaces with light in the 245 nanometer wavelength of the light spectrum (UV-C). UV-C light has proven effective in killing most bacteria, molds, and viruses in both laboratory and practical application. This complete package of equipment and ultraviolet lights includes Intertek Services Inc. (ETL) safety agency certification.

**Figure 24: Ultraviolet Lights**

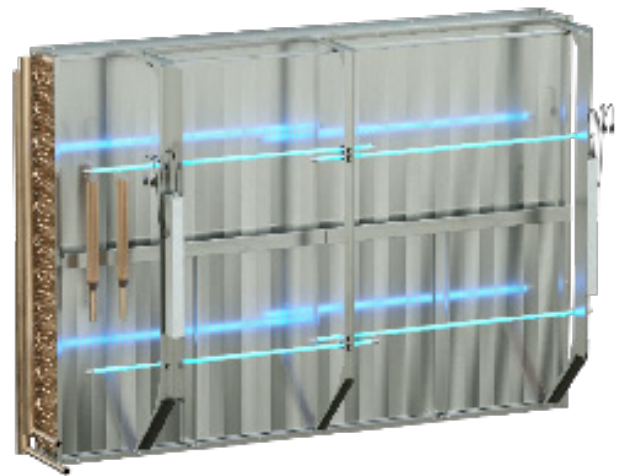

## MicroTech 4 Controller with SiteLine™ Building Controls

The MicroTech 4 controller rises above legacy systems by offering more advanced technology with controls that make equipment management easier. Manage equipment performance with fan airflow measuring, refrigeration and filter system performance analytics and power consumption in real time.

The unit controller is preprogrammed with the software necessary to control the unit. Use the unit controller keypad display to keep schedules, set points and parameters from being lost, even during a long-term power outage. The unit controller processes system input data and then determines and controls output responses. An optional field- or factory-mounted BACnet or LonWorks communication module provides a network interface to the BAS.

Add optional field configurable I/O modules to add additional sensors or points that are not standard on rooftop equipment and report them through the BAS.

### SiteLine Building Controls

- Easy installation with out-of-the box functionality for both new and retrofit applications
- Simple operation that brings insight to system performance and is intuitive to manage
- Low upfront costs that enable you to work with other equipment systems
- Scalable solutions for both standalone equipment and building systems
- Advanced security that protects customer data

### Refrigeration Only Controls

Refrigeration Only Controls provides the benefits of Daikin refrigeration system protections but allows for direct third-party control of major system components. Cooling, Heating, Damper and Fan Capacities are all controlled directly by a third-party controller.

These are example operations of typical system applications. The MicroTech 4 controller provides flexibility beyond these sequences. Contact your local sales rep to discuss specific application sequences.

## General

The MicroTech 4 controller provides users with full control over unit operation, occupancy, optimal start functionality, and scheduling. Advanced functionality like discharge air temperature reset, smoke controls, refrigeration and filter load monitoring and others are also available.

The MicroTech 4 can be configured to interact with up to (3) Analog or Network Space Sensors and up to (2) Humidity Sensors. These sensors can be set to operate the unit based on the highest, lowest or average reading across the sensors.

## Single Zone Variable Air Volume

Single Zone VAV control operates the unit as a single VAV box. The cooling is controlled to maintain a discharge air temperature setpoint and the supply fan is modulated to maintain a space temperature setpoint, the occupied cooling and occupied heating setpoint.

## Variable Air Volume

Variable Air Volume control operates the supply fans to maintain a duct pressure setpoint. The duct pressure varies as the VAV boxes throughout the served spaces modulate based on load. The cooling is controlled to maintain a discharge air temperature setpoint and the supply fan is modulated to maintain a space temperature setpoint, the occupied cooling and occupied heating setpoint.

## 100% Outside Air Application

100% Outside Air Systems can be configured to supply neutral temperature, dehumidified air or to provide cooling to the space. The cooling is controlled to maintain a discharge air temperature setpoint and the supply fan is configured to deliver the correct ventilation volume using airflow measuring, CO<sub>2</sub>, building pressure and more. Dehumidification is controlled using outdoor and/or space humidity sensors and free reheat is used to control the supply air temperature during dehumidification operation.

## Building Pressure Control

Units equipped with return or exhaust fans can be configured to control building pressure directly or via several indirect methods like, fan tracking, flow differential control, duct pressure control, or airflow control.

## Outdoor Air Control

Units may be configured with a 100% outdoor air (OA) damper, a 0-100% OA Economizer, or a 0-30% OA damper. During occupied, normal operation, units with a 0-30% OA or 0-100% OA economizer damper control to a minimum outdoor air position which is determined from a number of control factors, including fans speed, CO<sub>2</sub> or other reset methods. During economizer operation, dampers will open beyond the minimum outdoor air control to provide free cooling.

If a unit is equipped with a 0-100% Outside Air Economizer, and the outdoor air is suitable for free cooling, the unit attempts to satisfy the cooling load by using the outdoor air before using mechanical cooling. If the control temperature is above the Occupied Cooling Setpoint by half the deadband and the outdoor air is suitable for free cooling, the unit will enter the Econo State. Outdoor air suitability for free cooling is determined based on the type of economizer selected. Economizer can be selected based on Comparative Drybulb, or Comparative Energy/Enthalpy control. Economizer fault diagnostics are available to provide a warning alarm indication of over economizing, under economizing, stuck dampers and excess outdoor air.

## Energy Recovery

Energy Recovery is provided by drawing outside air across half of an energy recovery wheel and drawing exhaust air across the other half. Latent and sensible heat is transferred from the hotter, moister air stream to the colder dryer air stream. In summer operation the direction of transfer is from the outdoor air to the exhaust air. In winter operation, the direction of transfer is from the warm exhaust air to the cold dry outdoor air. Control of the wheel consists of start and stopping the wheel, and modulating the speed. The outdoor air dampers and supply and exhaust fans are controlled normally during wheel operation. Frost prevention is controlled using a VFD or an electric preheater coil on the energy recovery device.

**Table 1: Rebel Applied 031 – 052 Physical Data**

| Data                                     | 31  | 35           | 40         | 50   | 52     |
|--|---|--------------|------------|------|--------|
| <b>Compressors - Standard Efficiency</b> |   |              |            |      |        |
| Staged Control Qty - hp                  | 4-5.5   | 4-7.5        | 4-9        | 4-10 | 4-11.5 |
| Capacity Control                         | 0/25/50/75/100                                      |              |            |      |        |
| Variable Control Qty - hp                | 2-5.5, 1-10V  | 2-7.5, 1-10V | 2-9, 1-10V | -    | -      |
| Capacity Control                         | 0/20-100%   |              |            |      |        |
| <b>Compressors - High Efficiency</b>     |   |              |            |      |        |
| Qty - hp                                 | 2-10V   | 2-10V        | 2-10V      | N/a  | N/a    |
| Capacity Control                         | 0/10-100%   |              |            |      |        |
| <b>Condenser Fans</b>                    |   |              |            |      |        |
| Qty/Diam/HP                              | 4/26"/1.5   |              |            |      |        |
| <b>Evaporator Coil</b>                   |   |              |            |      |        |
| Rows/FPI                                 | 4 or 6 rows/ 12 FPI                                 |              |            |      |        |
| FA (sqft) - Standard                     | 26.5  | 26.5         | 26.5       | 26.5 | 26.5   |
| FA (Sqft) - Optional                     | 35.4  | 35.4         | 35.4       | 35.4 | 35.4   |
| Circuits                                 | 2, Fully Interlaced                                 |              |            |      |        |
| <b>Condenser Coil</b>                    |   |              |            |      |        |
| FA (sqft)                                | 110   |              |            |      |        |
| Type                                     | Microchannel  |              |            |      |        |
| <b>Supply Fans</b>                       |   |              |            |      |        |
| Type                                     | ECM SWSI Plenum Fan Array                           |              |            |      |        |
| Row × Columns (Qty)                      | 1 × 2 (2) or 2 × 2 (4)                              |              |            |      |        |
| Diameter (in)                            | 355(12"), 450(18"), 500( 20"), 560 (22"), 630 (25") |              |            |      |        |
| Motor Range kw (hp)                      | 1.1 kW – 9.8 kW                                     |              |            |      |        |
| <b>High Static Return Fans</b>           |   |              |            |      |        |
| Type                                     | Direct-dive ECM SWSI Plenum Fan Array               |              |            |      |        |
| Row × Columns (Qty)                      | 1 × 2 (2)   |              |            |      |        |
| Diameter (in)                            | 450(18"), 500( 20"), 560 (22"), 630 (25")           |              |            |      |        |
| Motor Range kw (hp)                      | 1.1 kW – 6.0 kW                                     |              |            |      |        |
| <b>Low Static Propeller Exhaust</b>      |   |              |            |      |        |
| Type                                     | Direct-dive Propeller Exhaust with VFD              |              |            |      |        |
| Row × Columns (Qty)                      | 1 × 2 (2), 1 × 3 (3)                                |              |            |      |        |
| Diameter (in)                            | 26"   |              |            |      |        |
| Motor Range (hp)                         | 1.5 HP  |              |            |      |        |
| <b>High Static Exhaust</b>               |   |              |            |      |        |
| Type                                     | Direct Drive ECM SWSI Plenum Fan Array              |              |            |      |        |
| Row × Columns (Qty)                      | 1 × 2 (2)   |              |            |      |        |
| Diameter mm (in)                         | 450(18"), 500( 20"), 560 (22"), 630 (25")           |              |            |      |        |
| Motor Range kw (hp)                      | 1.1 kW – 6.0 kW                                     |              |            |      |        |
| <b>Gas Furnace</b>                       |   |              |            |      |        |
| Nom. Input (MBH)                         | 200, 400, 600, 800, 1200                            |              |            |      |        |
| Nom. Output (MBH)                        | 162, 324, 486, 648, 972                             |              |            |      |        |
| Efficiency                               | 81%   |              |            |      |        |
| <b>Electric Furnace</b>                  |   |              |            |      |        |
| Nom. kW Input (varies by voltage)        | 10-200kW  |              |            |      |        |
| <b>Hot Water Coils</b>                   |   |              |            |      |        |
| FA (sqft)/Rows/Fins                      | 20.6ft <sup>2</sup> / 1 or 2 row / 8,10,12 FPI      |              |            |      |        |
| FA (sqft)/Rows/Fins                      | 26.9ft <sup>2</sup> / 1 or 2 row / 8,10,12 FPI      |              |            |      |        |
| <b>Steam Coils</b>                       |   |              |            |      |        |
| FA (sqft)/Rows/Fins                      | 20.3 ft <sup>2</sup> / 1 row / 6,8,10 FPI           |              |            |      |        |
| FA (sqft)/Rows/Fins                      | 26.6 ft <sup>2</sup> / 1 row / 6,8,10 FPI           |              |            |      |        |

**Table 2: Rebel Applied 031 – 052 Filter Information**

| Data                                       | 31                               | 35 | 40 | 50 | 52 |
|--|----------------------------------|----|----|----|----|
| <b>Panel Filters</b>                       |                                  |    |    |    |    |
| Thickness (MERV)                           | 2" (8), 4" (13)                  |    |    |    |    |
| Area (sqft)                                | 42.67 ft <sup>2</sup>            |    |    |    |    |
| Qty – Size                                 | (8) - 20" x 24", (4) - 24" x 24" |    |    |    |    |
| <b>Pre Filters (for cartridge filters)</b> |                                  |    |    |    |    |
| Thickness (MERV)                           | 2" (8)                           |    |    |    |    |
| Area (sqft)                                | 38.3 ft <sup>2</sup>             |    |    |    |    |
| Qty – Size                                 | (9) - 20" x 24", (3) - 20" x 20" |    |    |    |    |
| <b>Cartridge Filters</b>                   |                                  |    |    |    |    |
| Thickness (MERV)                           | 4" (15), 12" (11,14,16)          |    |    |    |    |
| Area (sqft)                                | 38.3 ft <sup>2</sup>             |    |    |    |    |
| Qty – Size                                 | (9) - 20" x 24", (3) - 20" x 20" |    |    |    |    |
| <b>Cartridge Final Filters</b>             |                                  |    |    |    |    |
| Thickness (MERV)                           | 12" (14, 16)                     |    |    |    |    |
| Area (sqft)                                | 35.6 ft <sup>2</sup>             |    |    |    |    |
| Qty – Size                                 | (9) - 20" x 24", (2) - 20" x 20" |    |    |    |    |
| <b>Face Load Final Filters</b>             |                                  |    |    |    |    |
| Thickness (MERV)                           | 12" (HEPA)                       |    |    |    |    |
| Area (sqft)                                | 34.0 ft <sup>2</sup>             |    |    |    |    |
| Qty – Size                                 | (6) - 24" x 24", (5) - 12" x 24" |    |    |    |    |
| <b>Large Wheel Filters</b>                 |                                  |    |    |    |    |
| Thickness (MERV)                           | RA = 2" (8) / OA = 4" (8)        |    |    |    |    |
| Area (sqft)                                | ft <sup>2</sup>                  |    |    |    |    |
| Qty - Size                                 | (4) - 20" x 24", (4) - 24" x 24" |    |    |    |    |
| <b>Small Wheel with Bypass Filters</b>     |                                  |    |    |    |    |
| Thickness (MERV)                           | RA = 2" (8) / OA = 4" (8)        |    |    |    |    |
| Area (sqft)                                | ft <sup>2</sup>                  |    |    |    |    |
| Qty – Size                                 | (4) – 20" x 24", (4) – 24" x 24" |    |    |    |    |

**Table 3: Gas Heat**

|                                  |              |                     |                     |                     |                     |
|----------------------------------|--------------|---------------------|---------------------|---------------------|---------------------|
| MBH Input                        | 200          | 400                 | 600                 | 800                 | 1125                |
| MBH Output                       | 162          | 324                 | 486                 | 648                 | 911                 |
| Staged                           | 2            | 2                   | 4                   | N/A                 | N/A                 |
| Modulating Turndown              | 5:1 or 100:1 | 5:1, 10:1, or 100:1 | 5:1, 10:1, or 100:1 | 10:1, 20:1 or 100:1 | 10:1, 20:1 or 100:1 |
| Minimum Gas Inlet Pressure       | 7.0 in. W.C  |                     |                     |                     |                     |
| Maximum Gas Inlet Pressure       | 0.5 psig     |                     |                     |                     |                     |
| Gas Pipe Connection Size (N.P.T) | 0.75         | 0.75                | 1.00                | 1.25                | 1.25                |

**Table 4: Propane Heat**

|                                  |             |            |        |             |             |
|----------------------------------|-------------|------------|--------|-------------|-------------|
| MBH Input                        | 200         | 400        | 600    | 800         | 1125        |
| MBH Output                       | 162         | 324        | 486    | 648         | 911         |
| Staged                           | 2           | 2          | 2 or 4 | N/A         | N/A         |
| Modulating Turndown              | 3:1         | 3:1 or 6:1 | 6:1    | 6:1 or 12:1 | 6:1 or 12:1 |
| Minimum Gas Inlet Pressure       | 7.0 in. W.C |            |        |             |             |
| Maximum Gas Inlet Pressure       | 0.5 psig    |            |        |             |             |
| Gas Pipe Connection Size (N.P.T) | 0.75        | 0.75       | 1.00   | 1.25        | 1.25        |

**Table 5: Electric Heat**

| Control       | 208V |       | 230V            |       | 460V            |       | 575V            |       |
|---------------|------|-------|-----------------|-------|-----------------|-------|-----------------|-------|
|               | kW   | MBH   | kW              | MBH   | kW              | MBH   | kW              | MBH   |
| 4 stages, SCR | 30   | 102.0 | 20 <sup>1</sup> | 62.4  | 20 <sup>1</sup> | 62.7  | 25 <sup>1</sup> | 170.6 |
|               | 45   | 153.0 | 40              | 124.7 | 40              | 125.0 | 45              |       |
|               | 60   | 204.0 | 55              | 187.1 | 55              | 188.0 |                 |       |
|               | 75   | 255.0 | 75              | 249.4 | 75              | 250.2 | 70              | 255.9 |
|               | 90   | 306.0 | 90              | 311.8 | 90              | 313.4 |                 |       |
|               | 105  | 357.0 | 110             | 374.3 | 110             | 375.1 | 115             | 341.2 |
|               | 120  | 408.0 | 130             | 436.5 | 130             | 438.7 | 135             | 426.5 |
|               |      |       | 150             | 498.9 | 150             | 500.1 |                 |       |
|               |      |       |                 |       | 165             | 564.0 | 160             | 511.8 |
|               |      |       |                 |       | 180             | 625.2 | 180             | 597.1 |
|               |      |       |                 | 220   | 750.2           | 230   | 682.4           |       |

**NOTE:** All electric heaters are available with either 4 stages of control or fully modulating SCR control

1. 2 stage only
2. All heaters have a max temp rise of 60°F

**Table 6: Energy Recovery Defrost Electric Pre-heater Sizes**

| Control | 208V |       | 230V |       | 460V |       | 575V |       |
|---------|------|-------|------|-------|------|-------|------|-------|
|         | kW   | MBH   | kW   | MBH   | kW   | MBH   | kW   | MBH   |
| SCR     | 10   | 34.1  | 10   | 34.1  | 10   | 34.1  | 10   | 34.1  |
|         | 20   | 68.2  | 20   | 68.2  | 20   | 68.2  | 20   | 68.2  |
|         | 40   | 136.5 | 40   | 136.5 | 40   | 136.5 | 40   | 136.5 |
|         | 60   | 176.7 | 60   | 195.5 | 60   | 204.7 | 60   | 204.7 |

**NOTE:** Electric Preheat does not come with Single Point Power if the unit is configured for primary heat electric heat.

Electric Preheat cannot be run simultaneously with mechanical cooling

Rebel Applied can be applied to meet a wide range of efficiency needs. Engineers can enhance efficiency by selecting one of 10 fan/array combinations, larger evaporator coils, and modulating condenser fan control.

**Table 7: Rebel Applied 031 – 052 Efficiency Ratings - Staged**

| Nom. Size | Condenser Ctrl | Standard Efficiency <sup>2</sup> |                  | Highest Efficiency <sup>3</sup> |                  |
|-----------|----------------|----------------------------------|------------------|---------------------------------|------------------|
|           |                | Fantrol®                         |                  | Speedtrol®                      |                  |
|           |                | 4 Row                            |                  | 6 Row                           |                  |
|           |                | Compressor Type                  | EER <sup>1</sup> | IEER                            | EER <sup>1</sup> |
| 31        | Staged         | 10.8                             | 15.0             | 11.5                            | 17.1             |
| 35        | Staged         | 10.5                             | 14.9             | 11.4                            | 16.6             |
| 40        | Staged         | 10.7                             | 14.6             | 11.4                            | 16.2             |
| 50        | Staged         | 10.1                             | 14.2             | 10.9                            | 15.6             |
| 52        | Staged         | 10.0                             | 14.0             | 10.4                            | 16.3             |

**NOTES:**

1. Cooling only/electric/hot water/steam – subtract 0.2 EER and 0.3 IEER for gas heat
2. Lowest efficiency fan array, 4 row DX coil, staged condenser fans
3. Highest efficiency fan array, 6 row DX Coil, modulating condenser fans

**Table 8: Rebel Applied 031 – 052 Efficiency Ratings - Variable/Variable**

| Nom. Size | Condenser Ctrl    | Standard Efficiency <sup>2</sup> |                  | Highest Efficiency <sup>3</sup> |                  |
|-----------|-------------------|----------------------------------|------------------|---------------------------------|------------------|
|           |                   | Speedtrol®                       |                  | Speedtrol®                      |                  |
|           |                   | 4 Row                            |                  | 6 Row                           |                  |
|           |                   | Compressor Type                  | EER <sup>1</sup> | IEER                            | EER <sup>1</sup> |
| 31        | Variable/Variable | 10.7                             | 18.1             | 11.5                            | 18.9             |
| 35        | Variable/Variable | 10                               | 17.1             | 10.9                            | 17.8             |
| 40        | Variable/Variable | 10                               | 17.2             | 10.5                            | 17.3             |
| 50        | Variable/Variable | N/A                              | N/A              | N/A                             | N/A              |
| 52        | Variable/Variable | N/A                              | N/A              | N/A                             | N/A              |

**NOTES:**

1. Cooling only/electric/hot water/steam – subtract 0.2 EER and 0.3 IEER for gas heat
2. Lowest efficiency fan array, 4 row DX coil, staged condenser fans
3. Highest efficiency fan array, 6 row DX Coil, modulating condenser fans

**Table 9: Rebel Applied 031 – 052 Efficiency Ratings - Variable/Variable**

| Nom. Size | Condenser Ctrl | Standard Efficiency <sup>2</sup> |                  | Highest Efficiency <sup>3</sup> |                  |
|-----------|----------------|----------------------------------|------------------|---------------------------------|------------------|
|           |                | Speedtrol®                       |                  | Speedtrol®                      |                  |
|           |                | 4 Row                            |                  | 6 Row                           |                  |
|           |                | Compressor Type                  | EER <sup>1</sup> | IEER                            | EER <sup>1</sup> |
| 31        | Variable/Fixed | 10.2                             | 16.3             | 11.9                            | 17.5             |
| 35        | Variable/Fixed | 10.3                             | 16.5             | 11.3                            | 17.2             |
| 40        | Variable/Fixed | 10.1                             | 15.8             | 11.1                            | 15.9             |
| 50        | Variable/Fixed | N/A                              | N/A              | N/A                             | N/A              |
| 52        | Variable/Fixed | N/A                              | N/A              | N/A                             | N/A              |

**NOTES:**

1. Cooling only/electric/hot water/steam – subtract 0.2 EER and 0.3 IEER for gas heat
2. Lowest efficiency fan array, 4 row DX coil, staged condenser fans
3. Highest efficiency fan array, 6 row DX Coil, modulating condenser fans

## Weights and Dimensions

Rebel Applied offers many section variations for application optimization. The section lengths of the different features and arrangements can vary greatly. Use [Table 10](#) as reference for the range of length possible per section and consult your local sales rep for a weight and length specific to your application needs.

**Table 10: Rebel Applied 031 – 052 Weights and Dimensions**

| Section                     | Features/Arrangements                           | Length  |
|-----------------------------|---|---------|
| Return                      | 0–30% Outside Air                               | 48-172" |
|                             | 100% Outside Air                                |         |
|                             | 100% Outside Air with Energy Recovery           |         |
|                             | 0–100% Economizer with Barometric Relief        |         |
|                             | 0–100% Economizer with Propeller Fans           |         |
|                             | 0–100% Economizer with High Static Exhaust Fans |         |
|                             | 0–100% Economizer with High Static Return Fans  |         |
| Filter                      | 0–100% Economizer with Energy Recovery          | 8–32"   |
|                             | 2" Pleated Filter                               |         |
|                             | 2"/4" Pleated Filter                            |         |
| Hot Water/Steam Preheat     | 2"/12" Cartridge                                | 36"     |
|                             | Hot Water                                       |         |
| DX Coil                     | Steam Coil                                      | 24"     |
|                             | Modulating Hot Gas Reheat                       |         |
| Reheat                      | UV Lights                                       | 12"     |
|                             | Modulating Hot Gas Reheat                       |         |
| Electric Heat               | Electric Heat                                   | 36"     |
| Hot Water/Steam Heat        | Hot Water/Steam Coil                            | 36"     |
| Backdraft Dampers           | (2) or (4) Damper                               | 24"     |
| Supply Fan                  | Blow Through Fan Section                        | 36"     |
|                             | Discharge Fan Section                           |         |
| Gas Heat                    | 200-1125 MBH furnace                            | 40–48"  |
| Final Filters               | Side Load Cartridge Filter                      | 32–44"  |
|                             | Face Load Filter                                |         |
| Blank/Access Sections       | Add up to 6 blank section in 24 to 48" lengths  | 24–48"  |
| Discharge Plenum            | Bottom, Right, Left, Top Discharge              | 40"     |
| Out of Air Stream Vestibule | 48" Vestibule Section                           | 48-72"  |
|                             | 72" Vestibule Section                           |         |



Figure 25: Examples of Rebel Applied Unit Layouts

**Basic Commercial**

- 50 ton
- Economizer with propeller exhaust
- Gas heat
- 1 × 2 ECM fan array
- 2" Merv 8 filters

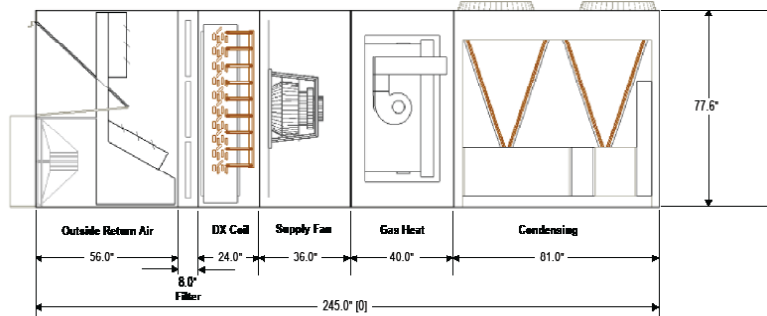

**Office**

- 50 ton
- Economizer with high static exhaust
- Gas heat
- 1 × 2 ECM fan array
- 2" Merv 8 filters

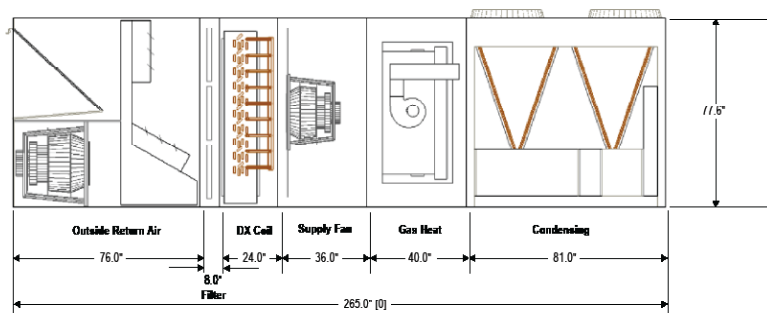

**Office 2**

- 50 ton
- Economizer with return fan
- Gas heat
- 2 × 2 ECM fan array
- 2" Merv 8 pre-filters and 12" MERV 14 cartridge filters

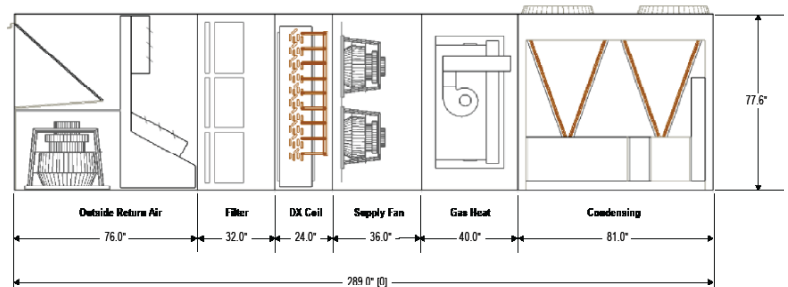

**Education**

- 50 ton
- Energy recovery wheel
- Gas heat
- 2 × 2 ECM fan array
- 2" Merv 8 filters

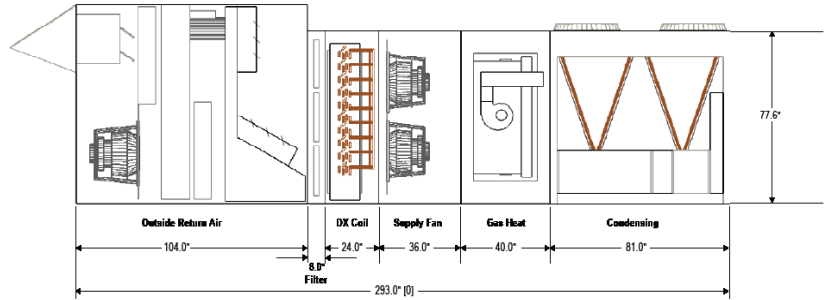

**100% Outside Air**

- 50 ton unit
- 100% Outside air damper
- 100 degree rise furnace
- 1 × 2 ECM fan array
- 2" MERV 8 filters

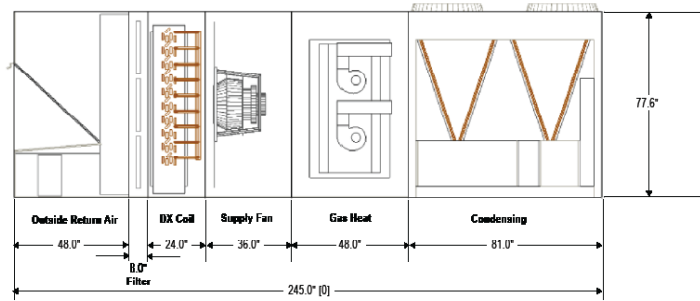

**100% Outside Air**

- 50 ton unit
- 100% Outside air damper
- Modulating liquid subcool coil
- 100 degree rise furnace
- 2x2 ECM fan array
- MERV 8 Filters

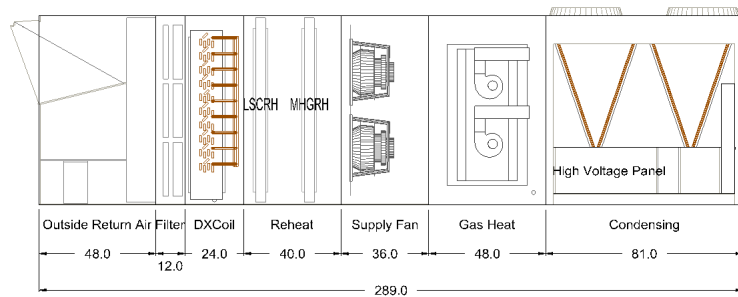
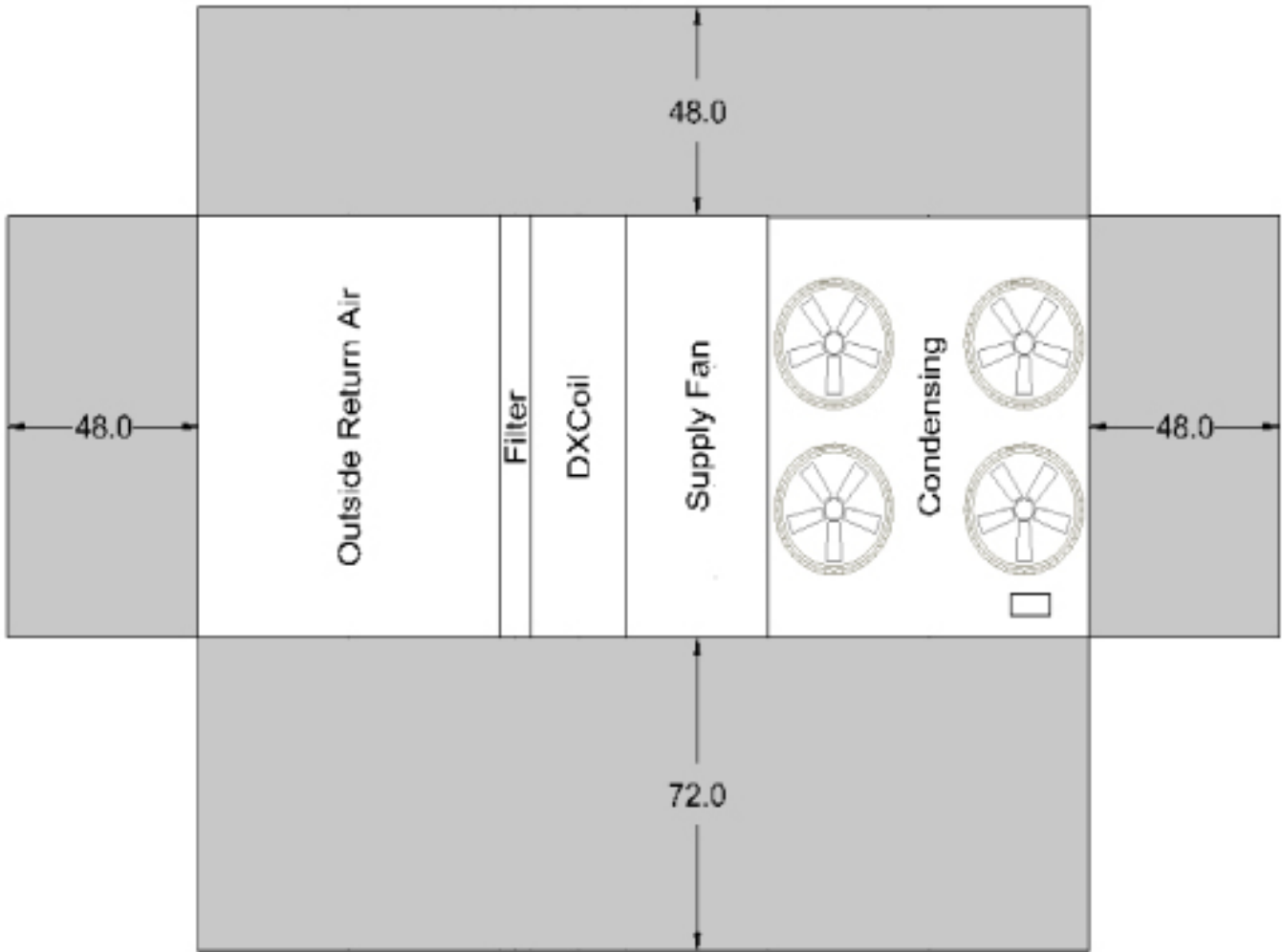

Figure 26: Rebel Applied Service Clearance

Top of unit needs unobstructed clearance



**Figure 27: Example of Rebel Applied Roof Curbs**

This roof curb drawing is representative and may not be correct for your application; drawings for a specific application need to be generated by your Daikin Sales Representative using the DaikinTools™ selection software.

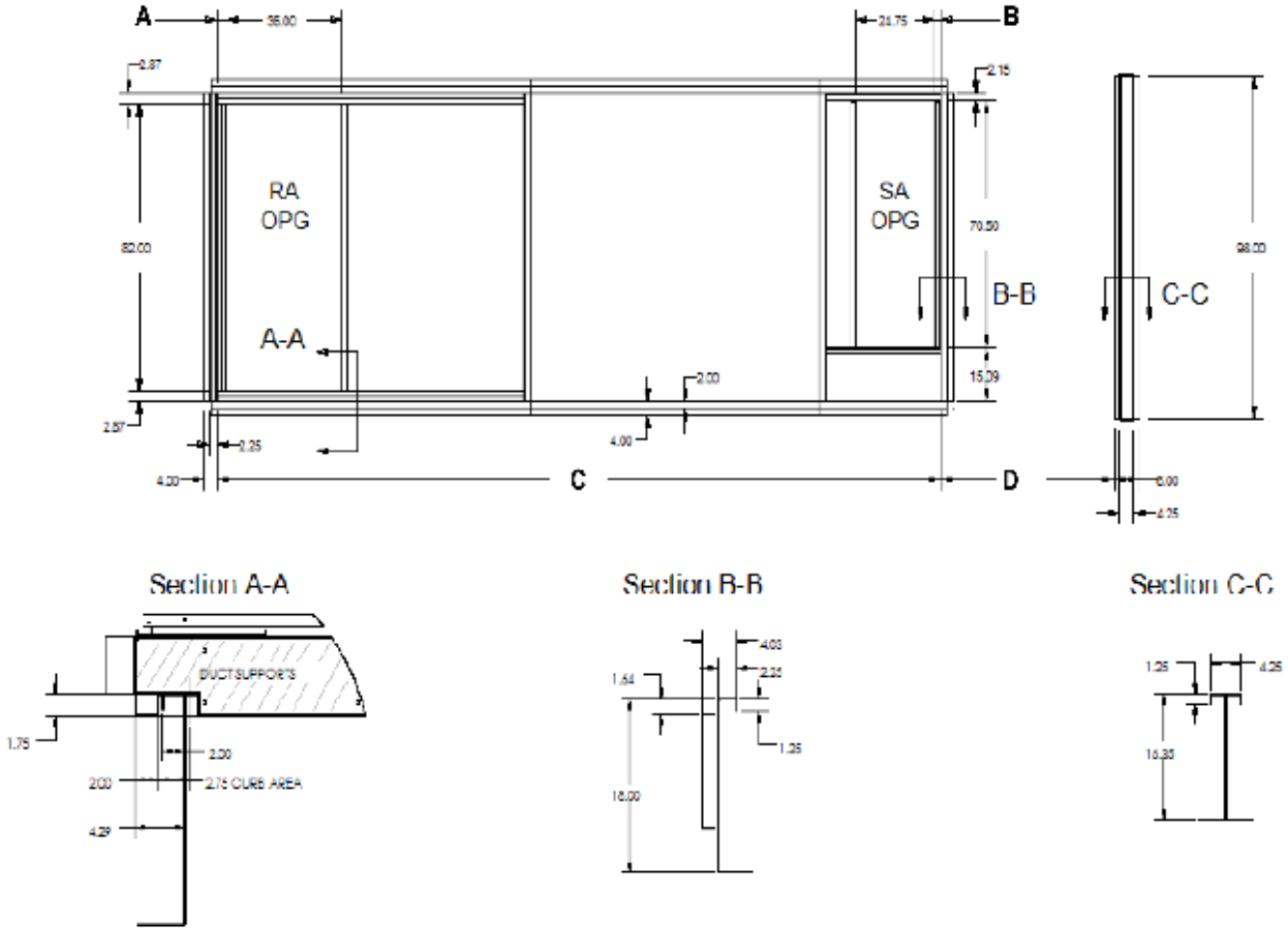

**Table 11: Roof Curb Variable Dimensions**

| 31-50 Tons                   |       |                             |       |                         |                |
|------------------------------|-------|-----------------------------|-------|-------------------------|----------------|
| A                            |       | B                           |       | C                       | D              |
| Return End Configuration     |       | Out of Air Stream Vestibule |       | AHU Length - 8"         | Condenser Size |
| Standard Return <sup>2</sup> | 2.93  | 48" Section                 | 49.78 | Configured <sup>1</sup> | 54"            |
| High Static Exhaust          | 30.11 | 72" Section                 | 73.78 |                         |                |
| Energy Recovery              | 56.11 |                             |       |                         |                |

**NOTES:**

1. The unit length is configured based on the application and selection. For exact job specific curb drawings, talk with your Daikin Sales Representative.
2. Standard Return Includes, 0-30% OA, 100% OA, Economizer with Low Pressure Exhaust, Economizer with Return Fan, Economizer with Offset Return Fan

The following section contains basic application and installation guidelines that must be considered as part of the detailed analysis of any specific project.

## General

Units are intended for use in normal heating, ventilating and air conditioning applications and 100% outdoor air application. Consult your local Daikin Sales Representative for applications involving operation at abnormal temperatures, high altitudes, non-cataloged voltages and for applications requiring modified or special control sequences. Consult your local Daikin sales representative for job specific unit selections that fall outside of the range of the catalog.

## Unit Location

The structural engineer must verify that the roof has adequate strength and ability to minimize deflection. Locate the unit fresh air intakes away from the building flue stacks or exhaust ventilators to reduce possible reintroduction of contaminated air to the system. Unit condenser coils should be located to avoid contact with any heated exhaust air.

## Service Clearances

Allow sufficient space around the unit for maintenance/service clearance. Refer to [Figure 25 on page 27](#) for recommended clearances. Where code considerations, such as the NEC require extended clearances, these take precedence. Provide a roof walkway along sides of the unit for service and access to controls and components. Consult your Daikin sales representative if available clearances do not meet minimum recommendations

## Operating Range

Daikin Rebel Applied rooftop systems are designed to operate over an extensive operating range. However, for proper system operation some limits do apply.

Most rooftop applications take advantage of the significant energy savings provided by economizer operation. When an economizer system is used, mechanical refrigeration is not typically required below an ambient temperature of 50°F. Standard Rebel Applied refrigeration systems are designed to operate in ambient temperatures down to 50°F. For applications where economizers cannot be used, the Rebel Applied is provided with a modulating condenser fan head pressure control and low ambient condenser coil control system for mechanical cooling operation in ambient temperatures down to -10°F.

To help prevent moisture blow-off, design guidelines have been established for cooling coil selection. Based on laboratory testing, average coil face velocities should not exceed 600 ft./min. For applications outside of these limits, consult your Daikin sales representative. Velocities exceeding these limits not only present the potential for moisture carryover, but also high face velocities generate high air pressure drops, resulting in poor fan energy performance

In addition to maximum face velocity limitations, minimum velocity guidelines must also be followed. In order to maintain proper refrigeration performance, the minimum coil face velocity is 150 ft./min. When selecting a variable air volume unit, it is necessary to design the system such that the 150 ft./min. limit is maintained at light load conditions.

## Acoustics

There are many sound sources in rooftop systems. Fans, compressors, condenser fans, duct take-offs, etc., all generate sound. Good acoustical design is critical for any installation and should start at the earliest stages in the design process. The common sound paths for rooftop equipment must be addressed are:

- Radiated sound through the bottom of the unit ( air handler and condensing unit section) into the space
- Radiated Sound to the property line
- Structure- borne vibration from the unit into the building
- Airborne sound through the supply air and return air ductwork

Some basic guidelines for good acoustical performance are:

- Provide proper structural support under all areas of the unit
- Locate equipment over less sensitive areas like corridors, toilet facilities or auxiliary spaces and away from office spaces, conference rooms and classrooms
- Design duct systems to minimize turbulence
- Place acoustical material in the area directly beneath the condensing section
- Apply for vibration isolation curb systems for sound transmission critical applications
- Account for low frequency duct breakout in system design. Route the first 20 ft. of rectangular duct over non-sensitive areas and avoid large duct aspect ratios. Consider round or oval duct to reduce breakout

Contact your local Daikin Sales Representative for equipment supply, return and radiated sound power data specific to your application.

## Ductwork Considerations

A well-designed duct system is required to allow the rooftop equipment to provide rated performance and to minimize system resistance and sound generation. Duct connections to and from units should allow straight, smooth airflow transitions. Avoid any abrupt changes in duct size and sharp turns in the fan discharge. Refer to the ASHRAE Applications Handbook for specific guidelines relevant to rooftop equipment.

The return duct path is the most often overlooked. A section of return duct is required to avoid “line of sight” to the return air opening and to provide attenuation of return air sound. Install an insulated tee with a maximum duct velocity of 1000 to 1200 feet per minute. Extend the duct 15 feet to provide adequate attenuation.

## PART 1: GENERAL

### 1.01 Section Includes:

- A. Semi-custom packaged rooftop air conditioners

### 1.02 References

- A. AFBMA 9 - Load ratings and fatigue life for ball bearings.
- B. AMCA 99 - Standards handbook.
- C. AMCA 210 - Laboratory methods of testing fans for rating purposes.
- D. AMCA 300 - Test code for sound rating air moving devices.
- E. AMCA 500 - Test methods for louver, dampers, and shutters.
- F. AHRI Standard 340/360- Unitary large equipment
- G. AHRI Standard 920 - DOAS
- H. AHRI Standard 1060 - Rating air-to-air heat exchangers for energy recovery ventilation equipment
- I. ASTM B117 - Standard practice for operating salt spray apparatus.
- J. NEMA MG1 - Motors and generators.
- K. NFPA 70 - National Electrical Code.
- L. UL 723 - Test for surface burning characteristics of building materials.
- M. UL 900 - Test performance of air filter units.
- N. UL 1995 - Standard for heating and cooling equipment.
- O. UL 94 - Test for flammability of plastic materials for parts in devices and appliances.
- P. IBC 2000, 2003 - International Building Code.
- Q. NFPA 90A - Standard for the installation of air conditioning and ventilating systems.
- R. NFPA 5000 - Building construction and safety code.
- S. ASHRAE 90.1 Energy Code.
- T. ASHRAE Std. 111 - Measurement, testing, adjusting, and balancing of building hvac systems

### 1.03 Submittals

- A. Shop drawings: Indicate assembly, unit dimensions, weight loading, required clearances, construction details, field connection details, electrical characteristics and connection requirements.
- B. Product data:
  1. Provide literature that indicates dimensions, weights, capacities, ratings, and electrical characteristics and connection requirements.
  2. Provide data on filter media, filter performance, filter assembly, and filter frames.
  3. Provide computer generated fan curves with specified operating point clearly plotted.
- C. Manufacturers must clearly define any exceptions made to plans and specifications. Any deviations in layout, arrangement, or efficiency shall be submitted to the consulting engineer prior to bid date. Acceptance of deviation (s) from specifications shall be in the form of written approval from the consulting engineer.

### 1.04 Operation and Maintenance Data

- A. Maintenance data: provide instructions for installation, maintenance and service

### 1.05 Qualifications

- A. Manufacturer: company specializing in manufacturing the products specified in this section with minimum five years documented experience, who issues complete catalog data on total product.
- B. Certify packaged rooftop performance in accordance with AHRI 340/360 standards
- C. Product energy efficiency compliant with ASHRAE 90.1 minimum energy efficiency requirements
- D. Startup must be done by trained personnel experienced with rooftop equipment.
- E. Do not operate units for any purpose, temporary or permanent, until ductwork is clean, filters and remote controls are in place, bearings lubricated, and manufacturers' installation instructions have been followed.

### 1.06 Delivery, Storage, and Handling

- A. Deliver, store, protect and handle products to site.
- B. Handle carefully to avoid damage to components, enclosures, and finish
- C. Store in a clean, dry place to protect from weather and construction traffic.

### 1.07 Warranty

## PART 2: PRODUCTS

### 2.01 Approved Manufacturers

- A. Basis of Design: Daikin Applied
- B. AAON: RL
- C. Trane: Intellipak
- D. Gouvernaire
- E. Seasons 4
- F. Engineered Air
- G. Energy Labs

### 2.02 General Description

- A. Each unit shall be specifically designed for outdoor rooftop application and include a weatherproof cabinet. Units shall be of a modular design with factory installed access sections available to provide maximum design flexibility.
- B. Furnish unit configuration, layout, performance and electrical characteristics as shown on project plans and schedule.
- C. The unit shall undergo a complete factory run test prior to shipment. The factory test shall include final test of all fan assemblies, a refrigeration circuit runtest, a unit control system operations checkout, a unit refrigerant leak test, and a final unit inspection.
- D. The complete unit shall be ETL listed.
- E. Unit shall be completely factory assembled and shipped in one piece.
- F. Unit to be shipped fully charged with R410A.
- G. All units shall have decals and tags to indicate caution areas and aid unit service. Unit nameplates shall be fixed to the main control panel door. Electrical wiring diagrams shall be attached to the control panels. Installation, operating and maintenance bulletins and start-up forms shall be supplied with each unit.
- H. Submittals must demonstrate that scheduled unit leaving air temperature (LAT) is met, that fan and motor heat temperature rise (TR) have been considered, and scheduled entering air temperature (EAT) equals mixed air temperature (MAT). Draw-thru cooling - Scheduled EAT equals cooling coil EAT and scheduled unit LAT equals cooling coil LAT plus TR.

### 2.03 Cabinet

- A. Unit construction for all walls, doors, ceiling and floor shall be double wall with a solid galvanized steel liner with a thermal break integral to the panel construction that provides a cleanable interior, prevents conductive heat transfer through the panel, and prevents exterior condensation on the panel.
- B. Unit construction for all walls, doors, ceiling and floor shall be double wall with a solid stainless steel liner with a thermal break integral to the panel construction that provides a cleanable interior, prevents conductive heat transfer through the panel and prevents exterior condensation on the panel.
- C. Foam Insulation shall provide a minimum thermal resistance R-value of 13.0.
- D. Unit construction shall be designed to operate at total static pressures up to 8.0 inches w.g.
- E. Provide quality unit construction with performance tested in accordance with ASHRAE Std 111 – cabinet air leakage shall not exceed leak class 6 ( $C_L = 6$ ), at +/- 5 in. w.c. casing pressure, where maximum cabinet leakage (cfm/100 ft<sup>2</sup> of casing surface area) =  $C_L \times P^{0.65}$ .
- F. Provide quality unit construction with air leakage less than 0.5% of design airflow up to 5 in. w.c.
- G. Provide quality unit construction with air leakage less than 1.0% of design airflow up to 7 in. w.c..
- H. Exterior surfaces shall be constructed of pre-painted galvanized steel for aesthetics and long term durability. Paint finish to include a base primer with a high quality, polyester resin topcoat of a neutral beige color. Finished surface to withstand a minimum 3000-hour salt spray test in accordance with ASTM B117 standard for salt spray resistance.
  - I. Access shall be provided to filters, dampers, cooling coils, fan sections, compressors and electrical and controls components.
  - J. Access doors shall be provided for each critical maintenance section in order to provide user easy access to components. All access doors shall be mounted on full length stainless steel piano hinges and shall be secured by linkage and latch system that is operated by a single handle. The latch system shall feature a staggered engagement for ease of operation and a safety catch shall protect the user from injury in case a positive pressure door is opened while the fan is operating. Doors secured by multiple, mechanical fasteners are not acceptable.
- K. The unit base frame shall be constructed of 13 gauge pre-painted steel to prevent base rail corrosion.
- L. The unit base shall overhang the roof curb for positive water runoff and shall have a formed recess that seats on the roof curb gasket to provide a positive, weathertight seal. Lifting brackets shall be provided on the unit base with lifting holes to accept cable or chain hooks.



**M. Service Lights**

1. Service lights shall be provided throughout the air handling unit and control panel. Lights shall be turned on from a single exterior switch on the exterior of the control panel. The lights will remain powered when the unit disconnect is OFF.
2. Service light enclosures shall have a minimum IP rating of 65 meaning the lights are dust tight and protected against jets of water. The light bulbs provided are a light-emitting diode (LED) type to minimize amperage draw and shall produce 1100 lumens in a warm white color.

**N. Burglar Bars**

1. A combination burglar bar shall be provided in the bottom supply air opening. Burglar bar shall be made of 3/4" diameter ground and polished steel shaft welded to a galvanized steel frame.

**O. Isolation Damper**

1. Isolation dampers shall be provided in the bottom supply air opening. A two-position actuator shall be provided to close the dampers when the fans are not running.
2. Isolation dampers shall be provided in the bottom return air opening. A two-position actuator shall be provided to close the dampers when the fans are not running.
3. Isolation dampers shall be provided in the bottom supply and return air openings. A two-position actuator shall be provided to close the dampers when the fans are not running.

**P. Safety Grates**

1. Walk on safety grates shall be provided in the bottom supply air opening and able to support a concentrated load of 1000lbs at mid-span.
2. Walk on safety grates shall be provide in the bottom return air opening and able to support a concentrated load of 1000lbs at mid-span.
3. Walk on safety grates shall be provided in the bottom supply and return air openings and be able to support a concentrated load of 1000lbs at mid-span.

**2.04 Acoustics**

- A. Equipment sound performance shall meet the scheduled discharge and return sound power
- B. Discharge plenum sections shall be lined with a perforated acoustic liner to enhance sound attenuation.
- C. Discharge and return plenum sections shall be lined with a perforated acoustic liner to enhance sound attenuation.

**2.05 Supply, Return and Exhaust Fans**

- A. All supply, return and exhaust fans shall be configured in an array with a minimum number fans specified in the schedule for each unit.
- B. Redundancy
  1. Size all fans for N-1 per the schedule
  2. Each supply, exhaust, and return fan motor shall have an independent integral inverter or a dedicated variable frequency drive per motor for redundancy.
  3. Provide the supply fan array with a backdraft damper section to prevent recirculation during redundant operation
- C. All fans shall be dynamically balanced as an assembly in planes as per DIN / ISO 21940 to balancing grade G 6.3 or better or provide 2" Spring isolation for each fan.
- D. All fans shall be provided with totally enclosed maintenance-free ball bearings and permanent lubrication. Bearings shall be selected for a minimum life in excess of 350,000 hrs (L50) at selected operating point.
- E. Fan airflow measuring
  1. All supply fans shall include a factory installed flow measuring station. Airflow needs to be readable through the unit controller and building automation system.
  2. All supply and exhaust fans shall include a factory installed flow measuring station. Airflow needs to be readable through the unit controller and building automation system.
  3. All supply and return fans shall include a factory installed flow measuring station. Airflow needs to be readable through the unit controller and building automation system.
- E. ECM Supply Fans
  1. All fans shall be a single width, single inlet (SWSI) airfoil centrifugal fan. The fan wheel shall be Class II construction with aluminum fan blades that are continuously welded to the hub plate and end rim. The fan shall be a direct drive fan mounted to the motor shaft. Belts and sheaves are not acceptable due to the additional maintenance.
  2. The fan motor shall be a totally enclosed electrically commutated motor that is speed controlled by the rooftop unit controller. The motor shall include thermal overload protection and protect the motor in the case of excessive motor temperatures. The motor shall have phase failure protection and prevent the motor from operation in the event of a loss of phase. Motors shall be premium efficiency.

**F. Propeller Exhaust Fan**

1. Direct-drive axial exhaust fans shall be provided. Blades shall be constructed with fabricated steel and shall be securely attached to fan shafts. All exhaust fan assemblies shall be statically and dynamically balanced. Totally enclosed motors shall be permanently lubricated, heavy-duty type, carefully matched to the fan load. Ground and polished steel fan shafts shall be mounted in permanently lubricated and sealed ball bearings. Bearings shall be selected for a minimum (L10) life in excess of 100,000 hours at maximum cataloged operating speeds.
2. The unit DDC controller shall provide building static pressure control. A factory mounted exhaust fan variable frequency drive shall provide proportional control of the exhaust fans from 25% to 100% of the scheduled exhaust air fan designed airflow and ESP. The field shall mount the required sensing tubing from the building to the factory mounted building static pressure sensor.

**H. ECM Exhaust Fan**

1. All fans shall be a single width, single inlet (SWSI) airfoil centrifugal fan. The fan wheel shall be Class II construction with aluminum fan blades that are continuously welded to the hub plate and end rim. The fan shall be a direct drive fan mounted to the motor shaft. Belts and sheaves are not acceptable due to the additional maintenance.
2. The fan motor shall be a totally enclosed electrically commutated motor that is speed controlled by the rooftop unit controller. The motor shall include thermal overload protection and protect the motor in the case of excessive motor temperatures. The motor shall have phase failure protection and prevent the motor from operation in the event of a loss of phase. Motors shall be premium efficiency.

**I. ECM Return Fans.**

1. All fans shall be a single width, single inlet (SWSI) airfoil centrifugal fan. The fan wheel shall be Class II construction with aluminum fan blades that are continuously welded to the hub plate and end rim. The fan shall be a direct drive fan mounted to the motor shaft. Belts and sheaves are not acceptable due to the additional maintenance.
2. The fan motor shall be a totally enclosed electrically commutated motor that is speed controlled by the rooftop unit controller. The motor shall include thermal overload protection and protect the motor in the case of excessive motor temperatures. The motor shall have phase failure protection and prevent the motor from operation in the event of a loss of phase. Motors shall be premium efficiency.
3. Exhaust Fan configurations are not allowed as alternate

**2.06 Electrical**

- A. Unit wiring shall comply with NEC requirements and with all applicable UL standards. All electrical components shall be UL recognized where applicable. All wiring and electrical components provided with unit shall be number and color coded and labeled according to the electrical diagram provided for easy identification.
- B. The unit shall be provided with a factory wired weatherproof control panel. Unit shall have a power terminal block for main power connection. A terminal board shall be provided for low voltage control wiring. Branch circuit short circuit protection, 115 volt control circuit transformer and fuse, system switches, and a high temperature sensor. Each compressor and condenser fan motor shall be furnished with contactors and inherent thermal overload protection. Supply and return fan motors shall have contactors and external overload protection. Knockouts shall be provided in the of the main control panels for field wiring entrance.
- C. All 115-600 volt internal and external wiring between control boxes and components shall be protected from damage by dedicated electrical raceways.
- D. The receptacle shall be powered by a field supplied 115V source.
- E. The receptacle shall be powered by a factory supplied 115V transformer and will be available when the disconnect is in the OFF position.
- F. Single non-fused disconnect switch shall be provided for connecting electrical power at the unit. Disconnect switches shall be mounted internal to the control panel and operated by an externally mounted handle.
- G. Unit SCCR Rating to be 10 kAIC minimum
- H. Unit SCCR Rating to be 22 kAIC. minimum
- I. Unit SCCR Rating to be 65 kAIC. minimum
- J. Unit shall be provided with phase, voltage and brown out protection which shuts down all motors in the unit if the electrical phases are more than 10% out of balance on voltage or on phase reversal.
- K. A dual non-fused disconnect switches shall be provided for connecting two power sources to the unit. Each disconnect switch shall be mounted internal to the control panel and operated by an externally mounted handle. Circuit 1 shall have the compressors, condenser fan, and electric heat (if present); Circuit 2 shall have the supply, return, exhaust fans, controls, and gas heat if present.
- L. Unit shall be provided with a safety shutdown terminal for installation of field emergency input.
- M. All electrical options shall have a +/- 10 percent voltage utilization range to protect against voltage variation.

## 2.07 Safety Options

- A. Unit Shall be provided with a safety shutdown terminal for installation of field emergency input
- B. Unit Shall be provided with factory installed supply air smoke detector
- C. Unit shall be provided with factory installed return air smoke detector
- D. Unit shall be provided with factory installed supply and return air smoke detector

## 2.08 Cooling Coil

- A. The cooling coil section shall be installed in a draw-through configuration, upstream of the supply air fan. The coil section shall be complete with factory piped cooling coil and sloped drain pan.
- B. Direct expansion (DX) cooling coils shall be fabricated of seamless 1/2" diameter high efficiency copper tubing that is mechanically expanded into high efficiency aluminum plate fins. Coils shall be a multi-row, staggered tube design with a minimum of 4 rows. All units shall have two independent refrigerant circuits and shall use an interlaced coil circuiting that keeps the full coil face active at all load conditions.
- C. Each refrigeration circuit shall be equipped with a thermostatic expansion valve for control refrigerant flow control.
- D. The cooling coil casing and all coil block offs shall be constructed with stainless steel to prevent corrosion.
- E. The refrigerant suction lines shall be fully insulated from the expansion valves to the compressors.
- F. The distributor tubes shall be sleeved or coated to provide longevity and protection from leaks.
- G. All coils shall be factory leak tested with high pressure air under water.
- H. The drain pan shall be stainless steel and designed to comply with ASHRAE- 62.1 double sloped requirements drain pan shall be provided with the cooling coil. The drain pan shall extend beyond the leaving side of the coil and underneath the cooling coil connections. The drain pan shall have a minimum slope of 1/8" per foot to provide positive draining. The drain pan shall be connected to a threaded drain connection extending through the unit base. Units with stacked cooling coils shall be provided with a secondary drain pan piped to the primary drain pan.
- I. Insulation under the drain pan should be a closed cell structure to prevent moisture from wicking under the drain pan. Fiberglass is not allowed.

## 2.09 Corrosion Protection

- A. All Indoor Heating and Cooling coils shall be provided with a corrosion protection coating rated for a minimum of 6000 hours of salt spray resistance per ASTM B 117-90 salt spray performance testing., ASTM B 117-90 salt spray performance.
- B. All Outdoor condenser coils shall be provided with a corrosion protection coating rated for a minimum of 6000 hours of salt spray resistance per ASTM B 11-7-90 salt spray performance testing, ASTM B 117-90 salt spray performance.
- C. All Indoor Heating and Cooling coils and the outdoor condenser coils shall be provided with a corrosion protection coating rated for a minimum of 6000 hours of salt spray resistance per ASTM B 11-7-90 salt spray performance testing, ASTM B 117-90 salt spray performance.

## 2.10 Modulating Hot Gas and Liquid Reheat

- A. Hot gas reheat: Unit shall be equipped with a fully modulating hot gas reheat coil with hot gas coming from the unit condenser
  - 1. Hot gas reheat coil shall be a Microchannel design. The aluminum tube shall be a micro channel design with high efficiency aluminum fins. Fins shall be brazed to the tubing for a direct bond. The capacity of the reheat coil shall allow for a 20°F temperature rise at all operating conditions.
  - 2. The modulating hot gas reheat systems shall allow for independent control of the cooling coil leaving air temperature and the reheat coil leaving air temperature. The cooling coil and reheat coil leaving air temperature set points shall be adjustable through the unit controller. During the dehumidification cycle the unit shall be capable of 100% of the cooling capacity. The hot gas reheat coil shall provide discharge temperature control within +/- 2°F.
  - 3. Each coil shall be factory leak tested with high-pressure air under water.
- B. Liquid sub-cool reheat: Unit shall be equipped with a fully modulating liquid sub-cool reheat coil using hot liquid coming leaving the unit condenser to reheat saturated leaving evaporator air to neutral air temperatures leaving the unit.
  - 1. Liquid sub-cool reheat coil shall be a Microchannel design. The aluminum tube shall be a micro channel design with high efficiency aluminum fins. Fins shall be brazed to the tubing for a direct bond.
  - 2. The modulating liquid sub-cool reheat system shall be utilized for independent control of the cooling coil leaving air temperature and the leaving/supply air temperature.

- C. Dehumidification operation with Hot gas reheat shall use direct air temperature feedback from the leaving face of the evaporator coil for controlling the compressor cooling capacity and the reheat will be fully modulate to maintain the leaving/ supply air temperature set point. The leaving/supply air temperature set point can be reset based on outside, space, and return temperature or humidity.
- D. Dehumidification operation with liquid sub-cool reheat shall use direct air temperature feedback from the leaving face of the evaporator coil for controlling the compressor cooling capacity and the reheat will be fully modulate to maintain the leaving/supply air temperature set point. If the liquid sub-cool coil does not have the capacity to meet the leaving air temperature set point, then the modulating hot gas reheat will trim the remaining reheat load required. The leaving/supply air temperature set point can be reset based on outside, space, and return temperature or humidity.

### 2.11 Chilled Water Coils

- A. The cooling coil section shall be installed in a draw-through configuration, upstream of the supply air fan. The coil section shall be complete with factory piped cooling coil and sloped drain pan. Hinged access doors on both sides of the section shall provide convenient access to the cooling coil and drain pan for inspection and cleaning.
- B. All coils are fabricated of seamless 5/8" diameter copper tubing that is mechanically expanded into high efficiency aluminum plate fins. Coils shall be multi-row, staggered tube design per the job schedule. All coils shall be factory leak tested with high-pressure air under water. All coils shall be ARI certified.
- C. Chilled water coils shall have copper headers complete with supply, return and threaded vent connections. Chilled water coils shall also include threaded drain connections. Glycol shall be used to the water circuit to protect against coil freeze-up. c
- D. 2-way chilled water control valves shall be factory installed and controlled and will be characterized Cv ball valves.

### 2.12 Hot Water Heat Coils

- A. A hot water heating coil shall be factory installed in the heat section. The rooftop unit shall include a piping vestibule. The coil connection shall terminate in the vestibule. All coil connections shall be copper, steel connections shall not be allowed in order to prevent dielectrics and corrosion.
- B. Coils shall be fabricated of seamless 5/8" diameter copper tubing that is mechanically expanded into high efficiency rippled and corrugated aluminum plate fins. All coil vents and drains shall be factory installed. Hot water coil shall be fully cased to allow for easy replacement.
- C. The coil shall have freeze protection and shall be controlled by the unit DDC controller. With the detection of a freeze condition the heating coil valve shall be driven fully open. The unit controller shall indicate an alarm.
- D. Coil shall be factory leak tested with high pressure air under water.
- E. Provide with a factory installed and control two-way characterized control valve with a normally open spring close actuator
- F. Provide with a factory installed and control two-way characterized control valve with a normally open spring close actuator and valve isolation valves
- G. Provide with a factory installed and control three-way characterized control valve with a normally open spring close actuator
- H. Provide with a factory installed and control three-way characterized control valve with a normally open spring close actuator and valve isolation valves

### 2.13 Steam Heat Coils

- A. A steam heating coil shall be factory installed in the unit heat section. Coils shall be fabricated of seamless 5/8" diameter copper tubing that is mechanically expanded into high efficiency HI-F rippled and corrugated aluminum plate fins. Steam coils shall be of the jet distributing type. A factory-tested diffuser shall be used in order to provide air distribution across the coil. Hinged access doors shall provide convenient access to the coil and valve for inspection and cleaning.
- B. A factory installed two-way modulating control valve and spring return valve actuator shall provide control of the steam. The valve actuator shall be controlled by the factory installed main unit control system.
- C. Coils shall be factory leak tested with high pressure air under water.

## 2.14 Electric Heat

- A. The rooftop unit shall include an electrical resistance heating coil section. Heating coils shall be constructed of a low watt density, nickel-chromium alloy resistance wire with intermediate supports that include ceramic bushings. The electrical contractors shall be of the full line-breaking type with all the electrical power legs being disconnected when the contactors are not energized. All electrical circuit wiring shall be designed with copper conductors, aluminum wires are not acceptable. Heating element branch circuits shall be individually fused to a maximum of 48 Amps per NEC requirements. The power supply for the electric heater shall be factory wired into the units main power block or disconnect switch.
- B. The heating modules shall have an automatic reset, high temperature limit safety protection. A secondary high limit protection shall also be provided that requires a manual reset. An airflow switch shall be provided with the heating module to prevent the electric heater from operating in the event of no airflow.
- C. The electric heat elements shall be controlled by the factory installed DDC unit control system. The heater shall have proportional SCR control. The unit controller shall modulate the electric heater to maintain the discharge air temperature set point.

## 2.15 Gas Heat

- A. The gas furnace design shall be factory installed downstream of the supply air fan in the heat section.
- B. The heat exchanger shall include a 439 grade stainless steel. Aluminized steel heat exchangers are not acceptable. The heat exchanger design shall collect condensate in a collection point and have a condensate drain.
- C. The furnace will be supplied with a staged induced draft burner. The burner shall be capable of 2 stages of control and will operate at either 50% or 100% of rated capacity.
- D. The furnace will be supplied with a staged induced draft burner. The burner shall be capable of 4 stages of control and will operate at either 25, 50, 75 or 100% of rated capacity.
- E. The furnace will be supplied with a modulating induced draft burner. The burner shall be controlled for low fire start. The burner shall be capable of continuous modulation between 20% and 100% (5:1 control) of rated capacity.
- F. The furnace will be supplied with a modulating induced draft burner. The burner shall be controlled for low fire start. The burner shall be capable of continuous modulation between 10% and 100% (10:1 control) of rated capacity.
- G. The furnace will be supplied with a modulating induced draft burner. The burner shall be controlled for low fire start. The burner shall be capable of continuous modulation between 5% and 100% (20:1 control) of rated capacity.
- H. The burner shall be specifically designed to burn natural gas and shall include a micro-processor based flame safeguard control, combustion air proving switch, pre-purge timer and spark ignition. Status and alarm codes are available at the unit controller via a network connection and are available for BAS integration.
  - I. Provide with a 10 year gas heat exchanger warranty
  - J. Provide with a 20 year gas heat exchanger warranty

## 2.16 Draw-through Filters

- A. All units shall be provided with clogged filter switches and alarm enunciation
- B. All units shall be provided with electronic pressure transducer filter measuring controls integrated with the BAS and alarm enunciation
- C. All units shall be provided with a through the wall magnehelic filter gauge that displays filter loading.
- D. Unit shall be provided with a draw-through filter section.
- E. The filter rack shall be designed to accept a 2" pleated filter. The manufacturer shall ship the rooftop unit with 2" MERV 8 filters. The contractor shall furnish and install, at building occupancy, the final set of filters per the contract documents.
- F. The filter rack shall be designed to accept a 2" pleated Merv 8 pre-filter and a 4" post filter. The manufacturer shall ship the rooftop unit with 2" MERV 8 filter. The contractor shall furnish and install, at building occupancy, the final set of filters per the contract documents.
- G. The filter rack shall be designed to accept a 2" pleated pre-filter and a 1" header for a up to a 12" cartridge filter. The manufacturer shall ship the rooftop unit with 2" MERV 8 pre-filters and a 12" MERV 14 cartridge filter.
- H. The filter rack shall be designed to accept a 2" pleated pre-filter and a 1" header for a up to a 12" cartridge filter. The manufacturer shall ship the rooftop unit with 2" MERV 8 pre-filters and a 12" MERV 16 cartridge filter.
- I. The filter rack shall be designed to accept a 2" pleated pre-filter and a 1" header for a up to a 12" cartridge filter. The manufacturer shall ship the rooftop unit with 2" MERV 8 pre-filters and a 12" Carbon Impregnatuded cartridge filter. The contractor shall furnish and install, at building occupancy, the final set of filters per the contract documents.

## 2.17 Blow-through Final Filters

- A. All units shall be provided with clogged filter switches and alarm enunciation
- B. All units shall be provided with electronic pressure transducer filter measuring controls integrated with the BAS and alarm enunciation
- C. All units shall be provided with a through the wall magnehelic filter gauge that displays filter loading.
- D. Unit shall be provided with a blow-through final filter section.
- E. The filter rack shall be designed to accept a side load 12" cartridge filter with a 1" header. The manufacturer shall ship the rooftop unit with 12" MERV 14 cartridge filter.
- F. The filter rack shall be designed to accept a face load 12" cartridge filter. The manufacturer shall ship the rooftop unit with 12" MERV 16 face load cartridge filter. A walk in access section upstream of face load filters is required for filter maintenance.
- G. The filter rack shall be designed to accept a face load 12" cartridge filter. The manufacturer shall ship the rooftop unit with 12" HEPA face load cartridge filter. A walk-in access section upstream of face load filters is required for filter maintenance.

## 2.18 Outdoor/Return Air Section

- A. Unit shall be provided with a Metal Mesh pre-filter in the outdoor air hood/section to prefilter large particulate to prevent early filter clogging.
- B. Unit shall be provided with a 0–30% Outside Air damper. The outdoor air hood shall be factory installed and constructed from galvanized steel finished with the same durable paint finish as the main unit. The hood shall include moisture eliminator filters to drain water away from the entering air stream. The outside and return air dampers shall be sized to handle 100% of the supply air volume. The dampers shall be parallel blade design. Damper blades shall be gasketed with side seals to provide an air leakage rate of 1.5 cfm/square foot of damper area at 1" differential pressure in according with testing defined in AMCA 500. Control of the dampers shall be by a factory installed direct coupled actuator.
- C. Unit shall be provided with a 100% Outside Air damper. The outdoor air hood shall be factory installed and constructed from galvanized steel finished with the same durable paint finish as the main unit. The hood shall include moisture eliminator filters to drain water away from the entering air stream. The outside and return air dampers shall be sized to handle 100% of the supply air volume. The dampers shall be parallel blade design. Damper blades shall be gasketed with side seals to provide an air leakage rate of 1.5 cfm/square foot of damper area at 1" differential pressure in according with testing defined in AMCA 500. Control of the dampers shall be by a factory installed direct coupled actuator.
- D. Unit shall be provided with an outdoor air economizer section. The economizer section shall include outdoor, return, and exhaust air dampers. The economizer operation shall be fully integral to the mechanical cooling and allow up to 100% of mechanical cooling if needed to maintain the cooling discharge air temperature. The outdoor air hood shall be factory installed and constructed from galvanized steel finished with the same durable paint finish as the main unit. The hood shall include moisture eliminator filters to drain water away from the entering air stream. The outside and return air dampers shall be sized to handle 100% of the supply air volume. The dampers shall be parallel blade design. Damper blades shall be gasketed with side seals to provide an air leakage rate of 1.5 cfm/square foot of damper area at 1" differential pressure in according with testing defined in AMCA 500. Control of the dampers shall be by a factory installed direct coupled actuator.
- E. Damper actuator shall be fully modulating and spring return type. A comparative drybulb control shall be provided to sense and compare drybulb in both the outdoor and return air streams to determine if outdoor air is suitable for "free" cooling. If outdoor air is suitable for "free" cooling, the outdoor air dampers shall modulate in response to the unit's temperature control system.
- F. Damper actuator shall be fully modulating and spring return type. A comparative enthalpy control shall be provided to sense and compare enthalpy in both the outdoor and return air streams to determine if outdoor air is suitable for "free" cooling. If outdoor air is suitable for "free" cooling, the outdoor air dampers shall modulate in response to the unit's temperature control system.
- G. A barometric exhaust damper shall be provided to exhaust air out of the unit. A bird screen shall be provided to prevent infiltration of rain and foreign materials.
- H. A power closure barometric exhaust damper shall be provided to exhaust air out of the back of the unit. The actuator will hold the damper shut during unoccupied mode. A bird screen shall be provided to prevent infiltration of rain and foreign materials.
- I. All units must be capable of CO<sub>2</sub> control. Outside air damper position will modulate between the Demand Control Ventilation Limit (minimum position setpoint) and the Ventilation Limit (maximum non-economizer position setpoint) to satisfy the space requirements. Damper position will be controlled to the greater of the two command signals, either minimum outside air flow or space IAQ (CO<sub>2</sub>).
- J. Provide the units with factory installed, and tested thermal dispersion style outdoor air flow measuring station.

## 2.19 Energy Recovery

- A. The rooftop unit shall be provided with an AHRI certified rotary wheel air-to-air heat exchanger in a cassette frame complete with seals, drive motor and drive belt. The energy recovery wheel shall be an integral part of the rooftop unit with unitary construction, power supply and controls and does not require field assembly. Bolt-on energy recovery units that require field assembly and section to section gasketing and sealing are not acceptable.
- B. The energy recovery wheels supplied must meet the scheduled capacity, and air pressure drop.
- C. The wheel capacity, air pressure drop and effectiveness shall be AHRI certified per AHRI Standard 1060. Thermal performance shall be certified by the manufacturer in accordance with ASHRAE Standard 84, Method of Testing Air-to-Air Heat Exchangers and AHRI Standard 1060, Rating Air-to-Air Heat Exchangers For Energy Recovery Ventilation Equipment.
- D. The rooftop unit shall be designed with a track so the entire energy recovery wheel cassette can slide out from the rooftop unit to facilitate cleaning.
- E. The unit shall have 4" Merv 8 filters for the outdoor air before the wheel to help keep the wheel clean and reduce maintenance. A dirty filter switch and alarm shall be provided on the Energy wheel filter rack.
- F. The total energy recovery wheel shall have an aluminum substrate and a 3 angstrom desiccant and shall have an adjustable purge for field balancing.
- G. A VFD shall be provided and modulated for wheel capacity and frost prevention control by the unit controller.
- H. A electric preheat coil with SCR control shall be provided and modulated to prevent frost on the energy recovery device. Provide sizing equivalent to the schedule.
- I. The rooftop unit with the energy recovery wheel shall incorporate the economizer operation. Units with economizers and energy recovery wheels shall have a bypass damper. When the unit is in the economizer mode of operation the energy recovery wheel shall stop and the bypass dampers shall be opened. The outdoor air shall be drawn through the bypass dampers to reduce the pressure drop of the outdoor airstream.

## 2.20 Discharge and Return Plenum Options

- A. A supply air discharge plenum shall be provided. The plenum section connection shall have a bottom, right, left, or top discharge opening consult the schedule and drawings for the final orientation.

## 2.21 Condensing Section

- A. All Units shall provide the Energy Efficiency specified EER and IEER per the schedule equipment or higher.
- B. Condenser fans shall be direct drive, axial type designed for low tip speed and vertical air discharge. Fan blades shall be constructed of steel and riveted to a steel center hub. Condenser fan motors shall be heavy-duty, inherently protected, three-phase, non-reversing type with permanently lubricated ball bearing and integral rain shield.
- C. Condenser coils shall be an all aluminum design, and mounted on polymer brackets, to minimize di-electric corrosion. The aluminum tube shall be a micro channel design with high efficiency aluminum fins. Fins shall be brazed to the tubing for a direct bond. Each condenser coil shall be factory leak tested with high-pressure air under water.
- D. Condenser coils shall be protected from incidental contact to coil fins by a coil guard. Coil guard shall be constructed of cross wire welded steel with PVC coating.
- E. Head Pressure Control
  1. Units shall have at least one condenser fan per circuit to maintain positive head pressure and an ambient temperature based fan cycling control to provide mechanical cooling down to 50°F
  2. Units shall have at least one condenser fan per circuit to maintain positive head pressure and a pressure transducer feedback per circuit to provide mechanical cooling down to 50°F
  3. Units shall have at least one condenser fan per circuit to maintain positive head pressure and a VFD on each circuit to modulate condenser fans to provide mechanical cooling down to 25°F
  4. Units shall have at least one condenser fan per circuit to maintain positive head pressure and a VFD on each circuit to modulate condenser fans to provide mechanical cooling down to -10°F
  5. Units shall have at least one condenser fan controlled to maintain positive head pressure. SpeedTrol condenser fan speed control shall be added to the last fan OFF on each refrigeration circuit to provide cooling operation to ambient temperatures down to 0°F. Fan speed control shall be field adjustable.
- F. Each unit shall have multiple, heavy-duty scroll compressors. Each compressor shall be complete with gauge ports, crankcase heater, sight-glass, anti-slug protection, motor overload protection and a time delay to prevent short cycling and simultaneous starting of compressors following a power failure. Compressors shall be isolated with resilient rubber isolators to decrease noise transmission.

- G. Each unit shall have two independent refrigeration circuits for redundancy. Each circuit shall be complete with a low pressure control, filter-drier, liquid moisture indicator/sight-glass, thermal expansion valve, and a manual reset high pressure safety switch. The thermal expansion valve shall be capable of modulation from 100% to 25% of its rated capacity. Sight-glasses shall be accessible for viewing without disrupting unit operation. Each circuit shall be dehydrated and factory charged with Refrigerant 410A and oil.
- H. Option for sizes 20-50 – Each unit shall have at least 4 compressor stages of cooling capacity control for better part load control as required by ASHRAE 90.1-2013.

## 2.22 Roof Curbs

- A. A prefabricated 12-gauge galvanized steel, mounting curb, designed and manufactured by the unit manufacturer, shall be provided for field assembly on the roof decking prior to unit shipment. The roof curb shall be a full perimeter type with complete perimeter support of the air handling section and rail support of the condensing section. Supply and return opening duct frames shall be provided as part of the curb structure allowing duct connections to be made directly to the curb prior to unit arrival. The curb shall be a minimum of 20" high and include a nominal 2"x4" wood nailing strip. Gasket shall be provided for field mounting between the unit base and roof curb.

## 2.23 Controls

- A. Each unit shall be equipped with a complete MicroTech 4 microprocessor based control system. The unit control system shall include all required temperature and pressure sensors, input/output boards, main microprocessor and operator interface. All boards shall be individually replaceable for ease of service. All microprocessors, boards, and sensors shall be factory mounted, wired and tested.
- B. The microprocessor shall be a stand-alone DDC controller not dependent on communications with any on-site or remote PC or master control panel. The microprocessor shall maintain existing set points and operate stand alone if the unit loses either direct connect or network communications. The microprocessor memory shall be protected from voltage fluctuations as well as any extended power failures. All factory and user set schedules and control points shall be maintained in nonvolatile memory. No settings shall be lost, even during extended power shutdowns.
- C. The main microprocessor shall support an RS-232 direct connection to a product service tool or a modem. A communications module shall be provided for direct communication into the BAS network.

- D. All digital inputs and outputs shall be protected against damage from transients or wrong voltages. Each digital input and digital output shall be equipped with an LED for ease of service. All field wiring shall be terminated at a separate, clearly marked terminal strip.
- E. The microprocessor shall have a built-in time schedule. The schedule shall be programmable from the unit keypad interface. The schedule shall be maintained in nonvolatile memory to insure that it is not lost during a power failure. There shall be one start/stop per day and a separate holiday schedule. The controller shall accept up to sixteen holidays each with up to a 5-day duration. Each unit shall also have the ability to accept a time schedule via BAS network communications.
- F. If the unit is to be programmed with a night setback or setup function, an optional space sensor shall be provided. Space sensors shall be available to support field selectable features. Sensor options shall include Zone sensor with tenant override switch, or Zone sensor with tenant override switch and heating/cooling set point adjustment.

## 2.24 Sorbent Ventilation

- A. Indoor air quality performance shall be in compliance with ASHRAE 62.1-2016 and relevant addenda via the Indoor Air Quality Procedure (IAQP).
- B. Air Cleaning Solution and Mechanism shall be fully compliant with ASHRAE Standard for Gas Phase Filtration: ASHRAE Standard 145.2 – 2011.
- C. Air Cleaning Solution shall be certified as zero-byproduct emitting by 3rd Party Certified Lab. Zero-byproduct certification letter required to be submitted to Engineer of Record and equipment Owner and/or Operator.
- D. Mechanism for air cleaning shall be capture and release; air cleaning solution alternates shall not alter the chemistry or composition of airborne gaseous substances. Alternate air-manipulative or catalytic type cleaners shall not be approved (i.e. plasma cleaners, ionizers, etc.)
- E. Solution shall not emit Ozone and/or Reactive Oxygen Species (ROS) of any kind; processes and mechanisms that emit ozone/ROS or have the potential to emit ozone or ROS are not acceptable.
- F. Solution shall have the capability to be automatically regenerated (self-cleaned) in-situ; replacement of cleaning mechanism or sorbent media shall not be required more than once per year.
- G. Gas-phase cleaning efficiencies must meet the following minimums for single-pass air cleaning of the following contaminants of concern: 1, Carbon Dioxide to have a measured standard challenge concentration of 1000 ppb, with a cartridge efficiency of 57%. 2. Formaldehyde to have a measured standard challenge concentration of 121 ppb, with a cartridge efficiency of 55%.
- H. Cartridge Bank: The cartridge bank shall house



twelve (12) quantity cartridges that contain the sorbents used to capture molecular level contaminants (CO<sub>2</sub>, formaldehyde, VOCs, ozone, etc. as defined by ASHRAE Standard 62.1-2016) during the sorption (cleaning) process and then released during the regeneration (airflow purge or exhaust) process.

- I. Heater: An integrated heater shall raise the internal temperature of the unit to initiate the release of captured contaminants by molecular thermal excitation. The heater shall be controlled using a PID controller loop to maintain the internal temperature. Temperature control shall be an on-board software-based function. Controller shall contain 3-modes of safety protection with respect to heater control that are mechanical in nature to ensure safe operation:1. An airflow switch that ensures the heater is disabled when there is insufficient airflow inside the unit.2. A resettable thermal switch shall disconnect the heater when the temperature exceeds a preset limit and will only allow the heater to operate once a safe temperature has been reached.3. A one-time blow fuse shall permanently disconnect the heater in the event the two primary safety functions fail to work.
- J. Fans: Integrated DC brushless motor driven fans shall control airflow through the unit during the adsorption and regeneration cycles. The fans are controlled using pulse width modulation for variable speed and are safety listed. The fan motors shall contain on-board locked rotor protection to prevent damage to the unit in the event of motor failure or the fan becomes blocked or locked in position.
- K. Inlets & Outlets: The module shall include airflow damper inlets and airflow damper outlets controlled and modulated by mechanical actuator assemblies.
- L. Internal Damper: An internal shunt damper shall be used during the regeneration cycle to enable the system to reach and maintain optimal temperature using airflow recirculation and mixing. The internal damper shall be controlled by an actuator allowing for analog position control to actively modulate the amount of recirculation during the regeneration.
- M. Control Board: The electronic enclosure shall contain both the power supply and main controller board. The power supply converts the incoming AC power to all voltages required to operate all aspects of the unit including actuators, heater, fans, and sensors. The controller contains the systems software, all controls/relays/sensor interfaces, and all wireless and wired communication modules.
- N. Insulation: All internal surfaces of the unit shall be covered in heat-reflective insulation material for improved efficiency and soundproofing. All outdoor-rated and weatherized equipment modules shall contain between-the-wall pressed insulation to maintain thermal efficiency.
- O. Outdoor-rated equipment modules shall have galvanized steel double-walled construction with 1000-hr salt spray rated power-coated paint. Indoor-based equipment modules are excluded from this specification.
- P. Power Requirements: The unit shall be designed

to work with single-phase AC power and should accommodate a range of line voltages and frequencies. Rated incoming line-voltage shall be 208-277V/ single phase at 60/50 Hz frequencies.

- Q. Airflow: Module airflow performance shall be based on no more than 0.2" w.g. of external static pressure. Maximum airflow shall not exceed 1000 CFM of cleaning capacity with a design nominal airflow of 800 CFM per single unit. Regeneration Cycle design maximum airflow shall not exceed 500 CFM of exhaust capacity with a design nominal airflow of 300 CFM per single unit.

## 2.25 Warranty

- A. The manufacturer shall provide 12 month parts only warranty. Defective parts will be repaired or replaced during the warranty period at no charge. The warranty period shall commence at start up, or 6 months after shipment, whichever ever occurs first.



### ***Daikin Applied Training and Development***

Now that you have made an investment in modern, efficient Daikin equipment, its care should be a high priority. For training information on all Daikin HVAC products, please visit us at [www.DaikinApplied.com](http://www.DaikinApplied.com) and click on Training, or call 540-248-9646 and ask for the Training Department.

### ***Warranty***

All Daikin equipment is sold pursuant to its standard terms and conditions of sale, including Limited Product Warranty. Consult your local Daikin Applied Representative for warranty details. To find your local Daikin Applied Representative, go to [www.DaikinApplied.com](http://www.DaikinApplied.com).

### ***Aftermarket Services***

To find your local parts office, visit [www.DaikinApplied.com](http://www.DaikinApplied.com) or call 800-37PARTS (800-377-2787). To find your local service office, visit [www.DaikinApplied.com](http://www.DaikinApplied.com) or call 800-432-1342.

This document contains the most current product information as of this printing. For the most up-to-date product information, please go to [www.DaikinApplied.com](http://www.DaikinApplied.com).

Products manufactured in an ISO Certified Facility.