



Catalog 1650-8

Daikin Classroom Unit Ventilators

**Model AEQ Self-Contained Air Source Heat Pump Floor Units
Size 024 (2 Ton) to 054 (4.5 Ton)**

MicroTech® and Electromechanical Controls (“J” Vintage)



Model AEQ

Introduction	3	Capacity Data	33
Daikin Classroom Unit Ventilators	3	Size 024 (1000 SCFM) – 2nd Stage High Fan	33
AHRI Performance Data – AEQ	4	Size 024 (750 SCFM) – 1st Stage Medium Fan	35
The Model AEQ Air Source Self-Contained Unit Ventilator	5	Size 024 (650 SCFM) – 1st Stage Low Fan	37
Features & Benefits	6	Size 036 (1250 SCFM) – 2nd Stage High Fan	39
The Right Amount of Fresh Air and Cooling	7	Size 036 (1000 SCFM) – 1st Stage Medium Fan	41
Precise Temperature and Dehumidification Control	7	Size 036 (800 SCFM) – 1st Stage Low Fan	43
Draw-Thru Design For Even Discharge Temperatures	8	Size 044 (1500 SCFM) – 2nd Stage High Fan	45
Low Installation Costs	8	Size 044 (1050 SCFM) – 1st Stage Medium Fan	47
Low Operating Costs	9	Size 044 (850 SCFM) – 1st Stage Low Fan	49
Easy To Maintain	10	Size 054 (1500 SCFM) – 2nd Stage High Fan	51
Built To Last	12	Size 054 (1050 SCFM) – 1st Stage Medium Fan	53
General Data	14	Size 054 (850 SCFM) – 1st Stage Low Fan	55
Nomenclature	14	Electrical Data	57
Model Type	15	Wiring Diagrams	59
MicroTech® Controls	16	Typical MicroTech Wiring Diagram	59
Accessories	18	Typical Wall Sensors Diagram	61
End Panels	18	Power & Control Field Wiring	61
Wall Sleeves	19	Electromechanical Control	63
Wall Louvers & Grilles	20	MicroTech Controls	65
VentiMatic™ Shutter Room Exhaust Ventilation	21	Control Modes and Functions	65
Details & Dimensions	22	External Input Functions	66
Physical Data	22	External Output Functions	66
Model AEQ Self-Contained Unit Dimensions – Size 024	23	Advanced Control Options	67
Model AEQ Self-Contained Unit Dimensions – Size 036	24	System Components	68
Model AEQ Self-Contained Unit Dimensions – Sizes 044, 054	25	MicroTech Control Sensor and Component Locations	69
End Panels	26	Room Temperature Sensors used with MicroTech Unit Controls	70
Wall Intake Louvers & Grilles	27	Actuators	71
VentiMatic Shutter Assembly	28	Application Considerations	73
Performance & Selection	29	Why Classrooms Overheat	73
Quick Selection Procedure	29	Meeting IAQ Requirements	75
Selection Procedure	30	Coil Selection	76
Cooling Selection Example	31	ASHRAE Cycle II	77
		Unit Installation	78
		Wall Louvers	79
		Lintels	79
		Wall Sleeve Arrangements	81
		Guide Specifications	84
		Model AEQ Air Source Heat Pump Self-Contained Unit Ventilator	84

Daikin Classroom Unit Ventilators



For nearly a century schools have relied on unit ventilators to keep classrooms comfortable.

Students learn more readily in a quiet, well-ventilated environment. That is why Herman Nelson invented the unit ventilator in 1917. Daikin Applied continues to set the industry standard for performance, features and quality. Today Daikin remains committed to continuing the Herman Nelson-AAF-McQuay legacy as the industry leader and meeting the changing requirements of schools with the highest quality unit ventilator products available.

We realize that keeping expenditures down is a high priority for school administrators and school boards.

Daikin unit ventilators are inexpensive to install and operate, and they are designed and built to provide years of trouble-free service.

Quiet Operation

Daikin unit ventilators are engineered and manufactured to deliver quiet, continuous comfort. We developed our GentleFlo™ air moving system to minimize operating sound levels—even as demands for more fresh air require units to operate longer and work harder.

The Right Amount of Fresh Air and Cooling

Daikin unit ventilators deliver required amounts of fresh air to meet ventilation requirements, and added cooling capacity to maintain consistent comfort for students and teachers. Our Economizer Operation, Demand Control Ventilation (DCV) and Part Load, Variable Air options allow you to closely match comfort requirements and reduce operating costs.

Precise Temperature and Dehumidification Control

Daikin unit ventilators feature precise temperature and dehumidification control to keep students and teachers comfortable while making maximum use of “free” outdoor-air cooling to reduce operating costs. They utilize a draw-thru air design that contributes to even heat transfer and uniform discharge air temperatures into the classroom.

Low Installation Costs

New construction installations are easily accomplished with Daikin unit ventilators because they avoid the added cost and space required for expensive ductwork. Retrofit installations are also economical because new units fit the same space occupied by existing ones. Factory installed MicroTech® controls with Protocol Selectability™ provide easy, low cost integration into the building automation system of your choice.

Low Operating Costs

Daikin unit ventilators minimize energy usage by utilizing a two-stage compressor and multi-speed fan to better match changing room loads. They take maximum advantage of “free” cooling opportunities to reduce operating costs. During unoccupied periods and at night, units operate sparingly to conserve energy.

Easy To Maintain, Modular Design

Daikin Unit Ventilators are designed to provide easy access for maintenance and service personnel to all serviceable components. Most tasks are easily handled by a single person.

Built To Last

Our proven institutional design can withstand the rigors of the classroom environment. It features an extra-sturdy chassis and double-wall damper on the inside; scuff-resistant finishes and tamper prevention features on the outside. In fact, many units installed over 30 years ago continue to provide quiet, reliable classroom comfort.

MicroTech® Control For Superior Performance, Easy Integration

Daikin unit ventilators can be equipped with MicroTech unit controllers for superior performance. Factory integrated and tested controller, sensor, actuator and unit options promote quick, reliable start-up and minimize costly field commissioning. Our Protocol Selectability feature provides easy, low-cost integration into most building automation systems. MicroTech controls have on-board BACnet® communication, with optional LONTALK® to communicate control and monitoring information to your BAS, without the need for costly gateways.

AHRI Performance Data – AEQ

Unit Size	Compressor Capacity	Fan Speed	Nominal Airflow	Cooling Performance		Heating Performance	
				Total Capacity	Efficiency	Total Capacity	Efficiency
			CFM	Btuh	EER	Btuh	COP
024	Full	High	1000	21000	9.7	19500	2.98
036	Full	High	1250	40000	10.4	36100	2.90
044	Full	High	1500	43500	10.0	42500	2.90
054	Full	High	1500	52000	10.2	52300	2.90

Notes: Cooling conditions: Indoor 80°F db/67°F wb-Outdoor; 95°F db/75°F wb and high-speed fan.
 Heating conditions: Indoor 70°F db/60°F wb-Outdoor; 47°F db/43°F wb and high-speed fan.



Since 1917



... and setting the standard today



The Model AEQ Air Source Self-Contained Unit Ventilator

Our model AEQ is a vertical, floor standing unit that utilizes refrigerant for cooling and heating. The Model AEQ is just right for new construction and for retrofit applications.

Older buildings with baseboard radiant heat or other hydronic heating systems can be easily adapted to work efficiently with the model AEQ unit. The major features of this model are shown below and described in more detail on the following pages.

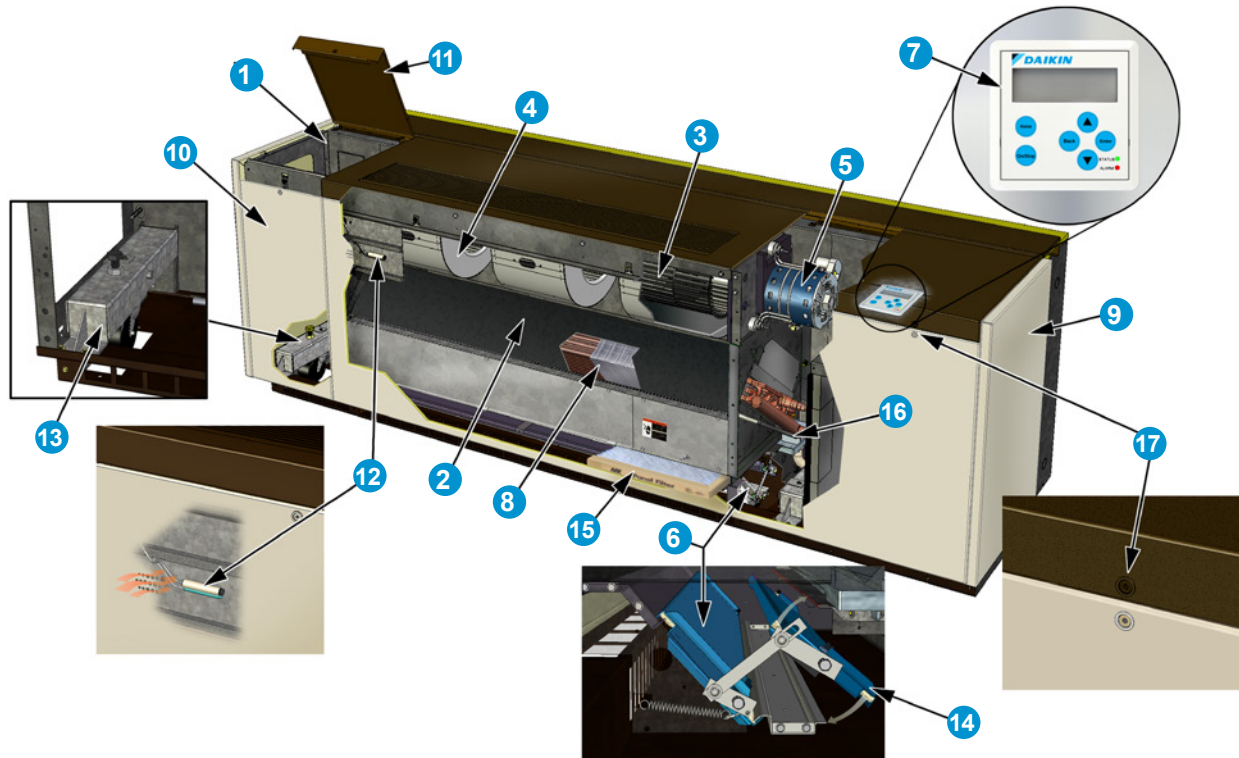

- | | | |
|--|---|--|
| <p>1 Welded one- piece chassis</p> <ul style="list-style-type: none"> • offers superior strength, durability, and vibration reduction <p>2 Unique draw-thru design</p> <ul style="list-style-type: none"> • provides uniform air distribution across the coil for even discharge air temperatures <p>3 Quiet, aerodynamic fans</p> <ul style="list-style-type: none"> • utilize GentleFlo technology for exceptionally quiet unit operation <p>4 Modular fan section</p> <ul style="list-style-type: none"> • improves balance, alignment and simplifies maintenance <p>5 Fan motor</p> <ul style="list-style-type: none"> • Located Out of Air Stream and away from heating coil reduces heat exposure to prolong life <p>6 Outside air/return air dampers & linkage</p> <ul style="list-style-type: none"> • Provides superior mixture of outdoor air and room air for precise temperature control | <p>7 MicroTech® controls (optional)</p> <ul style="list-style-type: none"> • provide superior comfort control and easy integration into the building automation system of your choice <p>8 Advanced heat transfer coil</p> <ul style="list-style-type: none"> • design provides extra capacity <p>9 Sturdy cabinet construction</p> <ul style="list-style-type: none"> • includes hidden reinforcement, a non-glare textured surface, and a tough, scuff- and mar-resistant finish to stand up to the abuses of a classroom environment <p>10 Sectionalized front access panels</p> <ul style="list-style-type: none"> • provide easy access to unit interior. Panels are easily removed by a single person. Front side panels can be removed while unit is running | <p>11 Two hinged top access doors</p> <ul style="list-style-type: none"> • provide easy access to the motor, electrical, and refrigeration components <p>12 Sampling chamber for unit-mounted sensor</p> <ul style="list-style-type: none"> • provides accurate sensing of room temperature <p>13 Optional adjustable caster</p> <ul style="list-style-type: none"> • (Left and Right Ends) <p>14 Insulated double-wall outdoor air damper</p> <ul style="list-style-type: none"> • seals tightly without twisting <p>15 Full-length air filter</p> <ul style="list-style-type: none"> • is efficient and easy to replace. All air delivered to classroom is filtered. <p>16 Sloped galvanized steel drain pan</p> <p>17 Tamper resistant fasteners on access panels</p> |
|--|---|--|

GentleFlo Delivery

Daikin unit ventilators are engineered and manufactured to deliver quiet, continuous comfort. We developed our GentleFlo™ air moving system to minimize operating sound levels – even as demands for more fresh air require units to operate longer and work harder. GentleFlo features include:

GentleFlo features include:

- Fan wheels are large, wide and rotate at a low speed to reduce fan sound levels. They are impact-resistant and carefully balanced to provide consistent performance.
- Offset, aerodynamic fan wheel blades move air efficiently (Figure 1).
- Precision tolerances help reduce flow and pressure turbulence, resulting in lower sound levels.

Figure 1: GentleFlo Fan Technology

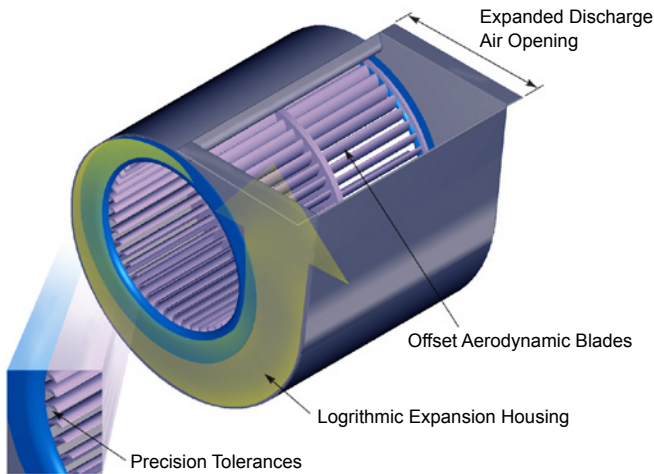

- Fan housings incorporate the latest logarithmic-expansion technology for smoother, quieter air flow (Figure 2).
- A large, expanded discharge opening minimizes air resistance, further lowering sound levels.
- Modular fan construction contributes to equal outlet velocities and promotes quiet operation.
- Fan shafts are of ground and polished steel to minimize deflections and provide consistent, long-term operation.
- Fan assemblies are balanced before unit assembly, then tested after assembly (and rebalanced if necessary) to provide stable, quiet operation.

Figure 2: GentleFlo Reduces Turbulence

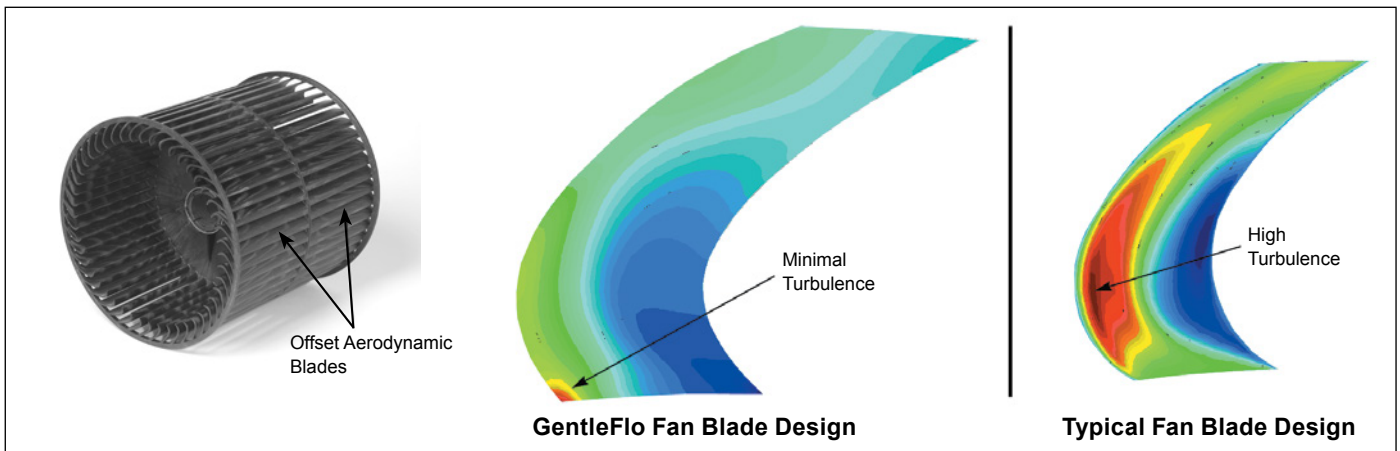

The Right Amount of Fresh Air and Cooling

Daikin unit ventilators deliver required amounts of fresh air to meet ventilation requirements and added cooling capacity to maintain consistent comfort for students and teachers. Our Economizer Operation, Demand Control Ventilation (DCV) and Part Load, Variable Air options allow you to match classroom comfort requirements even more closely, and reduce operating costs.

This means that you can be confident that your school is meeting ventilation standards for Indoor Air Quality and that your students are receiving adequate air to be attentive to instruction. At the same time, you are saving money in early morning hours, between classes or after hours when classrooms are heated and cooled but not always fully occupied.

Economizer Operation

It is well recognized that cooling, not heating, is the main thermal challenge in school classrooms. The typical classroom is cooled by outdoor air over half the time, even in cold climates. It is therefore essential that unit ventilators efficiently deliver outdoor air when classroom conditions call for “free” or economizer cooling.

With Daikin unit ventilators, you can have outdoor air whenever it is needed. Economizer operation is facilitated by the outdoor air damper, which automatically adjusts the above-minimum outside air position to provide free cooling when the outdoor air temperature is appropriate (Figure 3). On units equipped with MicroTech control, three levels of economizer control are available.

Figure 3: Full Economizer Mode

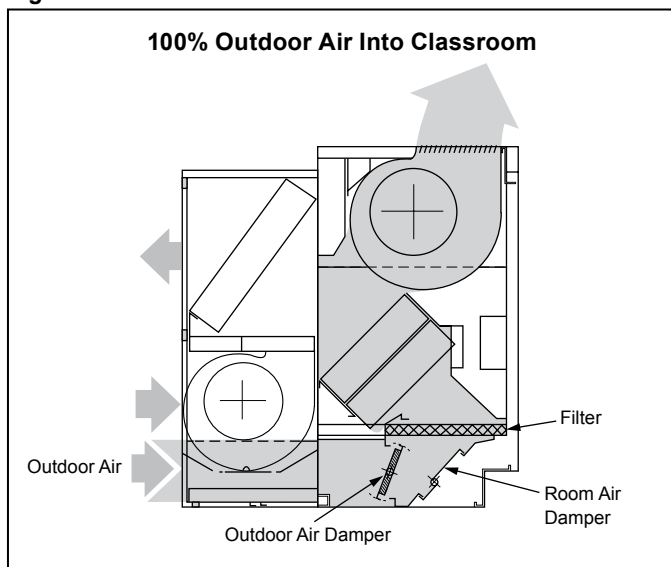

Part-Load Variable Air Control

Part Load Variable Air control can be used to automatically adjust the unit ventilator fan speed based upon the room load and the room temperature. This MicroTech control option provides higher latent cooling capabilities and quieter operation during non-peak load periods by basing indoor fan speed upon room load.

Lower fan speeds in conjunction with our GentleFlo fan technology contributes to a very quiet classroom environment.

Room-temperature PI control loops determine the speed of the fan, which varies according to the room load. It also provides a built-in delay to prevent overshooting for better comfort control. The outdoor air damper’s minimum-air position is adjusted with the fan speed to bring in a constant amount of fresh air.

Demand Control Ventilation

Daikin unit ventilators can be equipped to use input from a CO₂ controller to ventilate the space based on actual occupancy instead of a fixed design occupancy. This Demand Controlled Ventilation (DCV) system monitors the amount of CO₂ so enough fresh outdoor air is introduced to maintain good air quality. The system is designed to achieve a target ventilation rate (e.g., 15 CFM/person) based on actual occupancy.

By using DCV to monitor the actual occupancy pattern in a room, the system can allow code-specific levels of outdoor air to be delivered when needed. Unnecessary over-ventilation is avoided during periods of low or intermittent occupancy, leading to improved energy efficiencies and cost savings.

Precise Temperature and Dehumidification Control

Daikin unit ventilators provide precise temperature and dehumidification control to keep students and teachers comfortable while making maximum use of “free” outdoor-air cooling to reduce operating costs. They utilize a draw-thru fan design that contributes to even heat transfer and provides uniform discharge air temperatures into the classroom. MicroTech control strategies and 2-stage compressor operation provide precise control of temperature and humidity levels under both part-load and full-load conditions.

Draw-Thru Design For Even Discharge Temperatures

The Daikin Draw-Thru design sets our unit ventilators apart from most competitive models. With this system, fans draw air through the entire heat transfer element (Figure 4) rather than blowing it through highly concentrated areas of the coil element. The result is more uniform discharge air temperatures into the classroom and more efficient unit ventilator operation.

Figure 4: Draw-Thru Design Provides Even Discharge Air

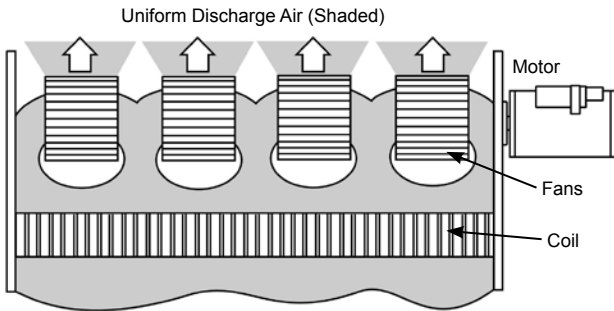
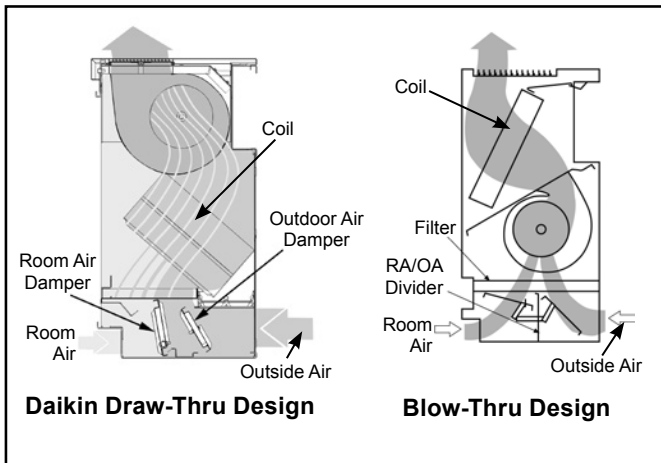

Figure 5: Draw-Thru Vs. Blow-Thru Design



Low Installation Costs

Daikin unit ventilators have many features that make them economical to purchase and to install in both new construction and retrofit applications. It is this attention to detail and understanding of school applications that make them the system of choice.

Perfect For Both New Construction & Retrofit Applications

New construction installations are easily accomplished with the Daikin Applied AEQ size 024 air source heat pump unit ventilator because of the avoided added cost and space required for expensive duct work. This is important in existing buildings and also in new construction where floor-to-floor heights can be reduced, saving on overall building costs. Further savings can be realized because air source heat pump self-contained unit installations use less space than units that require water supply and return piping.

Retrofit installations are economical because new units typically fit the same space occupied by existing ones.

Controls Flexibility

Multiple control options—including MicroTech controls with our Protocol Selectability feature—provide easy, low cost integration of Daikin unit ventilators into the building automation system of your choice (See "MicroTech Controls" on page 65).

MicroTech controls come with on-board BACnet MS/TP communications, or with optional LON TALK, to communicate control and monitoring information to your BAS, without the need for costly gateways.

Low Operating Costs

Schools consume more than 10% of the total energy expended in the United States for comfort heating and cooling of buildings. As energy costs increase, educators are placed in a difficult position: caught between rising costs, lower budgets and the requirements to raise educational standards.

Fortunately, the technology and the system exists for schools to take control of their energy expenditures while providing a comfortable environment for learning. And that system is the Daikin unit ventilator.

Consider these realities of school environments:

- Most heating energy in schools is expended to heat unoccupied spaces. Because lights, computers and students give off considerable heat, occupied spaces require little supplemental heat.
- The removal of heat is usually required in occupied classrooms, even when outside temperatures are moderately cold (i.e., 35 to 40°F).
- Then consider how Daikin unit ventilators, located in each classroom, take advantage of these realities to lower operating costs:
- They provide individual classroom control and comfort.
- They can be cycled on when the room is occupied and cycled off when it is not.
- They bring in fresh air from directly outside the classroom for high indoor air quality.
- During most of the school year, they use outdoor air to keep classrooms comfortable without the expense of mechanical cooling.

MicroTech® Control Options Further Reduce Operating Costs

Many of the MicroTech control options available with Daikin unit ventilators can further reduce operating costs. For example:

- **Economizer Operation:** Economizer operation automatically adjusts the above-minimum outside air position to provide free cooling when the outdoor air temperature is appropriate.
- **Demand Control Ventilation:** By using CO₂ levels to monitor the actual occupancy pattern in a room, the system can allow code-specific levels of outdoor air to be delivered when needed without costly over-ventilation during periods of low or intermittent occupancy (Figure 6).

Figure 6: Energy Savings with Demand Control Ventilation

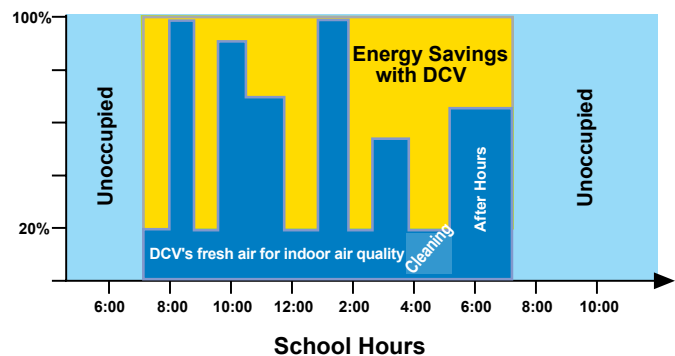

- **Occupancy Mode Operation:** Units can be programmed to operate only sparingly during unoccupied periods and at night to conserve energy.

Two-Stage Compressor

Air conditioning units are usually sized for worse case conditions. During high load requirement the unit will operate in high fan speed and high compressor capacity. Most of the time there is not a full load on the compressor. Operation in lower load will be at medium or low fan speeds which will be at the lower displacement compressor stage. The two stage compressor will remain at low speed until more cooling is required. With the two-stage compressor, the unit will run on lower fan speeds most of the time improving comfort through better humidity control and quieter operation, while minimizing issues with over-sizing.

Other units utilizing single stage compressors operate at full compressor capacity all of the time regardless of fan speed.

Easy To Maintain

Daikin Unit Ventilators are designed to provide easy access for maintenance and service personnel to all serviceable components. Most maintenance tasks are easily handled by a single person.

Modular Fan Deck

The entire fan deck is easily removed as a single unit. This provides ready access to fan wheels, motors, bearings and other components for service, cleaning or repair.

The fan deck's rotating element has one large, self-aligning end bearing and a permanently lubricated motor bearing for smooth operation. On most sizes the location of the fan shaft bearing is at the end of the shaft (out of the air stream). This enables easy access for oiling on units built with an oilable end bearing (some units built with permanently sealed end bearings).

Figure 7: Long-Life Bearings

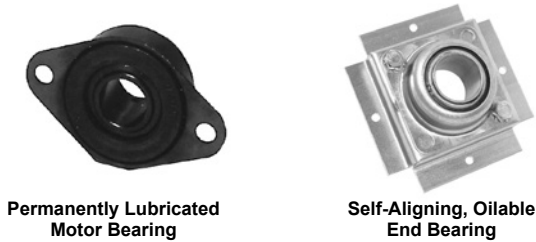

Heavy-Duty Discharge Grille

The discharge grille on the top of the unit is made from extra-strength steel bar stock, promoting long life (Figure 8). It can be removed to facilitate cleaning of fans and fan housings. A built-in 10-degree angle provides proper air throw to blanket the room for proper air circulation and comfort.

Figure 8: Heavy-Duty Steel Discharge Grille

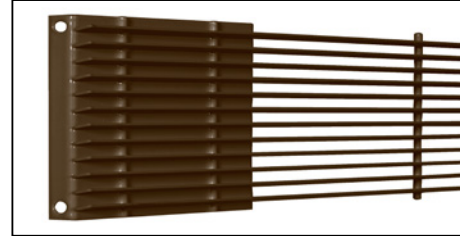

Easy Motor Removal

Unlike with many competitive models, the motor in Daikin unit ventilators is separate from the fan assembly and is located out of the airstream at the end of the fan shaft—away from the hot coil—for easier maintenance and removal. Locating the motor away from the coil (Figure 9) has the added benefit of extending motor life. Our direct-coupled motor and self-aligning motor mount facilitate motor change-out. The motor comes with a molex plug that fits all sizes and further simplifies removal.

Figure 9: Modular Design

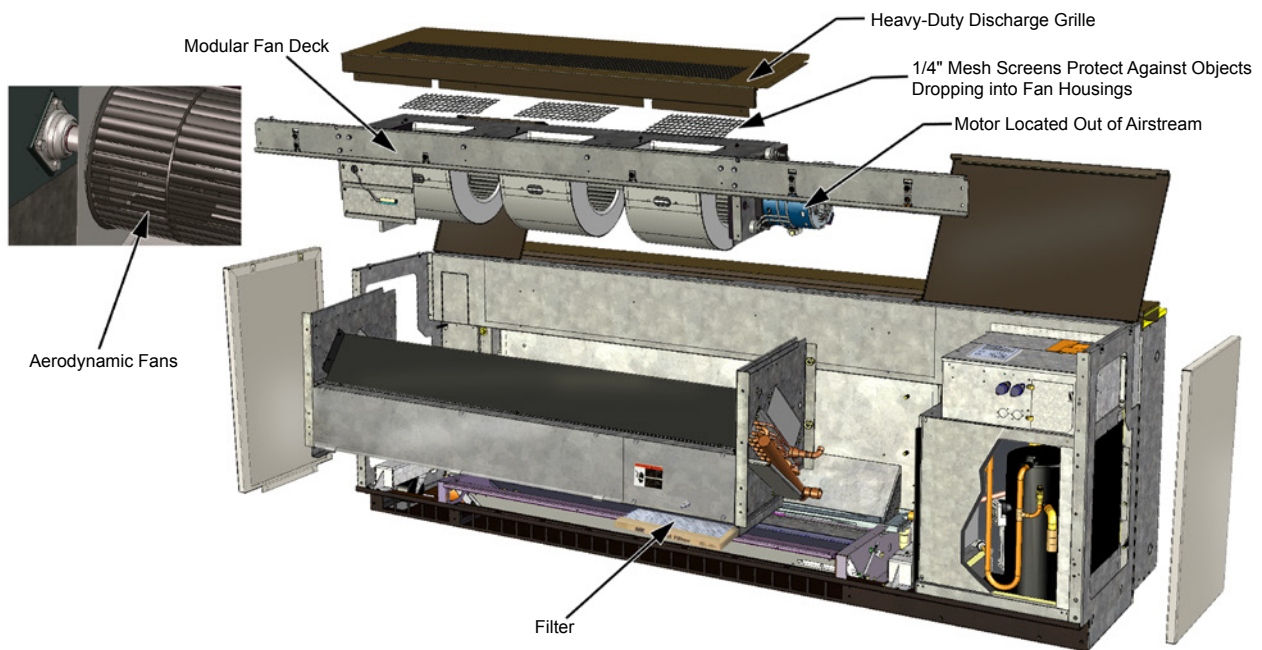

Tamper-Resistant Fasteners

Front panels and top access doors are held in place by tamper-resistant, positive-positioning fasteners. They are quickly removed or opened with the proper tool, but deter unauthorized access to the unit's interior (See Figure 11).

Sectionalized Access Panels and Doors

All units have three separate front panels and hinged top access doors, sized for convenient handling by a single person (See Figure 11). The result is easy, targeted access to the component that needs servicing:

- Two end panels provide easy access to piping, temperature control components and the fan switch. Unlike units with full-length front panels, these can be removed without disturbing the normal operation of the unit.
- Hinged top access doors provide easy access into the end compartments to facilitate convenient servicing of the motor, electrical, and refrigeration components.
- Center front panel provides easy access to the filter and the fan shaft bearing on unit sizes 044 and 054.

Filter

Three filter types are offered:

- Units come standard with a single-use filter which is designed to be used once and discarded.
- Optional, permanent metal filters are available and can be removed for cleaning and reused numerous times.
- Renewable media filters, which consist of a heavy-duty, painted-metal structural frame and renewable media.

Figure 10: Easy Access to Filter

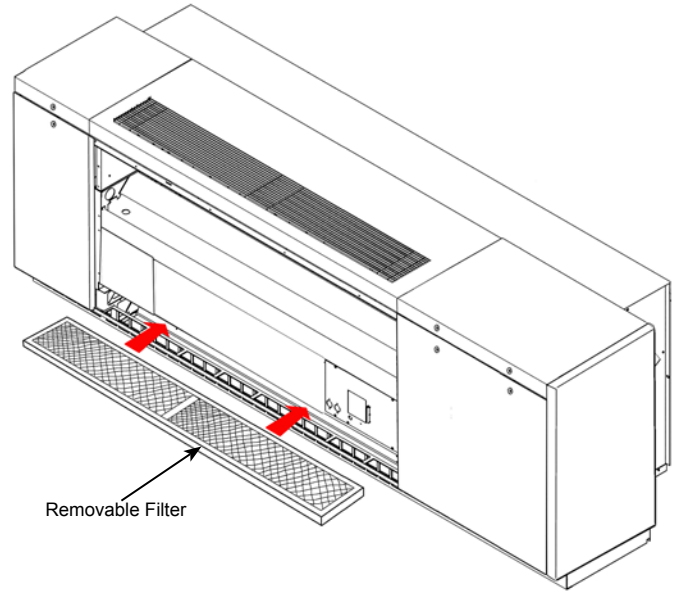
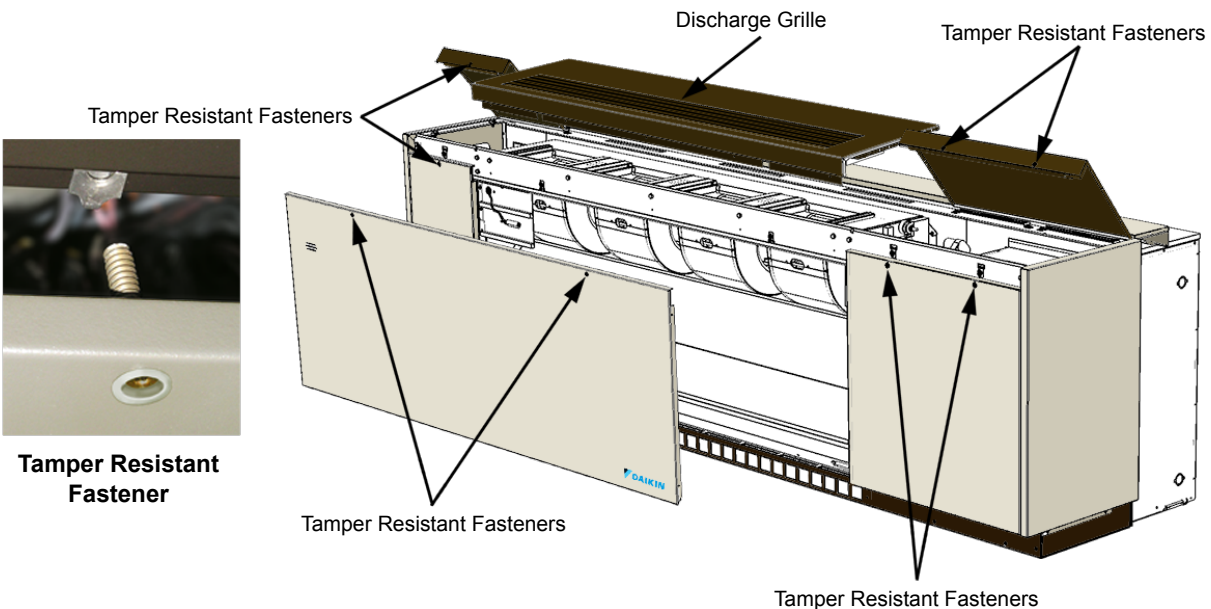

Figure 11: Easy Access with Tamper-Resistant Fasteners



Built To Last

Our industrial-strength design provides the durability to withstand the rigors of the classroom environment. Its solid construction and rugged finish promotes continued alignment, structural strength and long-lasting beauty decades after the unit is installed. In fact, many units installed over 30 years ago continue to provide quiet, reliable classroom comfort.

Heavy Duty Frame Construction

Daikin's exclusive, unitized frame (Figure 12) is far superior to the fastener-type construction used by other manufacturers. Loosened fasteners can cause vibration, rattles and sagging panels. With unitized construction, there are no fasteners (screws or bolts) to come loose.

Other design features that promote trouble-free operation and long life include:

- A corrosion-resistant, galvanized-steel frame.
- Extra-strength, steel-bar discharge grille.
- Heavy-gauge-metal cabinet access panels and doors.
- An extra-strength pipe tunnel that stiffens the structure while adding aerodynamic air flow within the unit.
- Hidden reinforcement that provides additional built-in support for the top section as well as better support for the fan deck assembly.
- A rigid exterior that is strong enough to support maintenance personnel without fear of damaging the unit.

Rugged Exterior Finish

The superior finish of the unit ventilator's cabinets fosters long-lasting beauty as well as resistance to abuse and corrosion. We apply the very highest standards at every step of the finishing process to provide lasting quality:

- High-quality furniture steel is carefully inspected before painting. Scratches and marks that might show through are removed.
- After fabrication, the metal undergoes a five-stage cleaning and phosphatizing process to provide a good bonding surface and reduce the possibility of peeling or corrosion.
- A specially formulated, environmentally friendly, thermosetting urethane powder is applied electrostatically to the exterior panels. This film is oven-cured to provide correct chemical cross-linking and to obtain maximum scuff- and mar-resistance.
- The top of the unit is finished with a textured, non-glare and scuff-resistant, charcoal bronze electrostatic paint. End and front panels are available in a pleasing array of architectural colors.
- The Oxford brown steel kickplate is coated and baked with a thermosetting urethane powder paint to blend with floor moldings and provide years of trouble-free service.
- Each unit is painstakingly inspected before boxing, then encapsulated in a clear plastic bag, surrounded by an extra-heavy-duty cardboard box and secured to a skid to help provide damage-free shipment.

Figure 12: Heavy-Duty, Welded Chassis

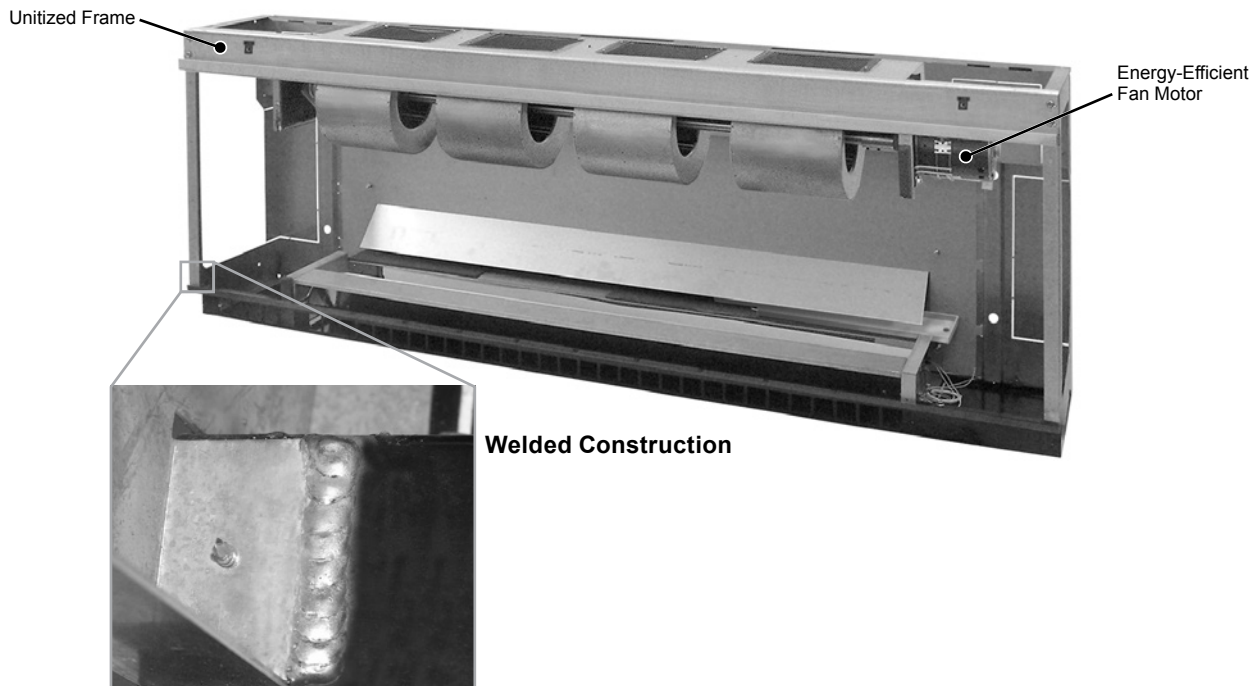

Durable, Energy Efficient Fan Motors

Daikin Applied unit ventilators are equipped with 115/60/1 NEMA motors that feature low operating current and wattage (Figure 13).

Figure 13: Energy-Efficient Fan Motor

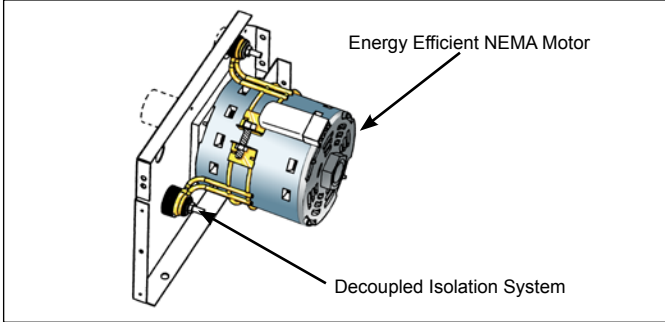

Additional features of these motors include:

- Split-capacitor (PSC) design with automatic reset and thermal-overload protection.
- No brushes, contacts or centrifugal starting switches the most common causes of motor failure.
- A built-in, decoupled isolation system to reduce transmission of vibrations for quieter operation.
- A multi-tap, auto-transformer (Figure 14) provides multiple fan motor speed control through the speed switch. The motor is independent of supply voltage, which allows stocking of one motor (school district-wide) for various voltage applications.

Figure 14: Multi-Tap Auto-Transformer



Electronically Commutated Motor (ECM)

The EC motor with almost no draw down of the unit's airflow (cfm) as static pressures increase. As a result, there is little need to oversize the unit to provide full air volume at high static pressures.

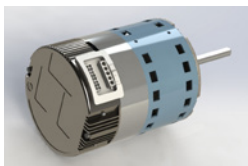

- Self adjusting for constant torque for part load efficiency.
- Available with 3-speed or variable airflow operation

Durable Damper Design

All dampers in Daikin Unit Ventilators use the turned-metal principle on their long closing edges (Figure 15). Positive sealing is provided by embedding the edge into wool mohair (no metal to metal contact). There are no plastic gaskets to become brittle with time, sag with heat or age, or require a difficult slot fit to seal. Nylon damper bearings foster quiet, maintenance-free operation.

Additional features include:

- Outdoor air dampers are made of galvanized steel to inhibit corrosion, with double-wall welded construction for rigidity and encapsulated insulation (Figure 15). Additional insulation is provided on the exterior of the outdoor air damper blade and on the outdoor air entry portion of the unit.

Figure 15: Outdoor Damper Seals Out Cold Weather

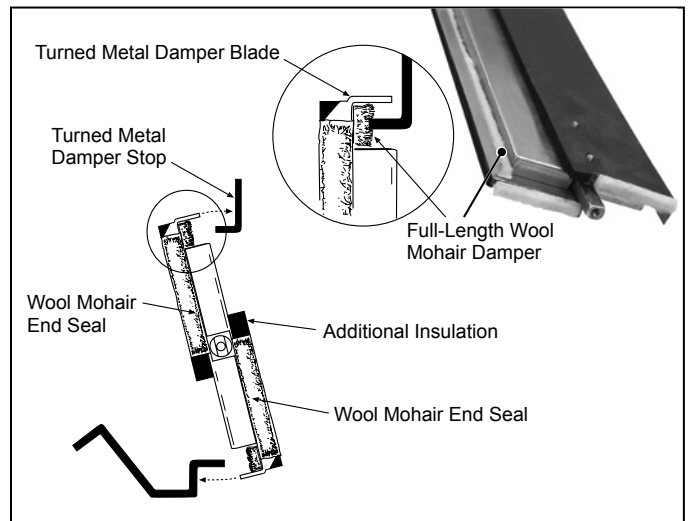

- Room air dampers are free-floating and designed to prevent intermittent gusts of cold air from blowing directly into the classroom on windy days (Figure 16). They are constructed of aluminum with built-in rigidity. The metal forming technique that is employed resists twisting and incorporates a full-length counter weight for easy rotation. The simple principle of an area exposed to a force is used to automatically close the damper, rather than open it, when gusts of cold air occur.

Figure 16: Room Air Damper Auto-Closed by Wind Gusts

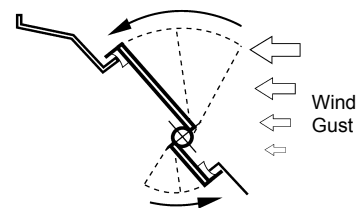

Nomenclature

U AEQ 9 024 H G 12 Z B1 AL 22 G I B 1
 1 2 3 4 5 6 7 8 9 10 11 12 13 14 15

Category	Code Item	Code Option	Code Designation & Description									
Product Category	1	1	U	Unit Ventilators								
Model Type	2	2-4	AEQ	Air Source Heat Pump								
Design Series	3	5	9	Design J								
			7	Design H (036, 044, 054)								
Nominal Capacity	4	6-8	024	24,000	044	44,000						
			036	36,000	054	54,000						
Voltage	5	9	C	208/60/1	H	230/60/3						
			G	230/60/1	K	460/60/3						
			D	208/60/3								
Coil Options	6	10	G	Direct Expansion	9	Direct Expansion with Stainless Steel Drain Pan						
			H	Direct Expansion with Refrigerant Relief Valve								
Heating Options	7	11-12	12	3 Element Low Cap. Electric Heat								
			13	6 Element Low Cap. Electric Heat								
Hand Orientation	8	13	Z	Not Available								
Controls CO ₂ = Return Air CO ₂ Sensor	9	14-15	##	MicroTech® Controls (see control code table below)								
			Control Features				Feature Selections					
			Open Protocol	BACnet / Stand-Alone	•		•		•	•		
				LONMARK		•		•			•	•
			DCV	CO ₂ Sensor			•	•		•		•
			Factory-Installed Keypad	LUI					•	•	•	•
							Control Code					
			Economizer Control	Basic	B1	B5	B9	BD	BH	BL	BP	BT
				Expanded	E1	E5	E9	ED	EH	EL	EP	ET
				Leading-Edge	L1	L5	L9	LD	LH	LL	LP	LT
44	Electromechanical w/2-Position OA Damper for Remote Thermostat											
Discharge	10	16-17	AL	16-5/8" Top Bar Grille								
Return Air/Outside Air	11	18-19	22	Return Air Bottom Front/ Outdoor Air Rear								
Power Connection	12	20	G	Box With Switch								
			J	Box w/switch, w/USB								
			K	Box w/switch, w/SD								
			M	Box w/switch, w/USB, w/SD								
Color	13	21	I	Antique Ivory	G	Soft Gray						
			W	Off White	C	Cupola White						
			B	Putty Beige								
SKU Type	14	22	B	Standard Delivery								
Product Style	15	23	1	1st Style Change								

Model Type

AEQ – Air Source Heat Pump

Model type AEQ units include a heat pump refrigeration circuit and supplemental electric heat. The full airflow is directed across the coils at all times. The refrigeration circuit is used as the primary source for cooling and heating. The electric heaters can be used to supplement the refrigeration heating output or provide all heat if compressor operation is not available. If the unit is equipped with a factory mounted humidity sensor or field connected humidistat the electric heat may also be used for reheat in a dehumidification mode.

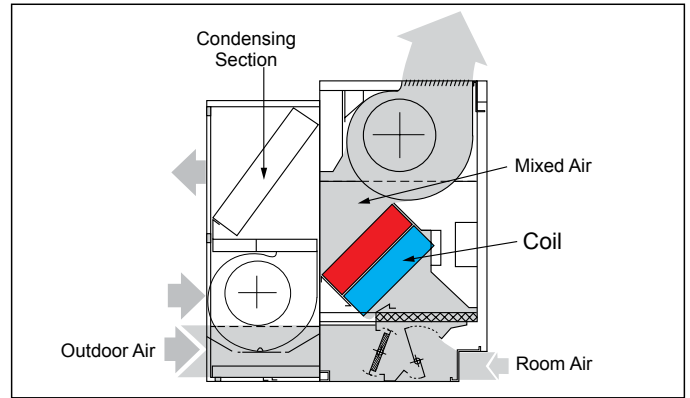

MicroTech® Controls



Daikin unit ventilators equipped with MicroTech controllers can provide superior performance and easy integration into your building automation system of choice. MicroTech benefits include:

- Factory integrated and tested controller, sensor, actuator and unit options promote quick, reliable start-up and minimize costly field commissioning.
- High-performance features and advanced control options can quickly pay for themselves in saved energy costs and more comfortable classrooms.
- Select from two control levels: stand-alone or network control.
- For network control applications, our Protocol Selectability feature provides easy, low-cost integration of Daikin unit ventilators into most building automation systems.
- Flexible BAS network communication options guard against controls obsolescence, keeping MicroTech controls viable for the life of your Daikin equipment.

Three Control Levels

MicroTech controllers provide the flexibility to operate Daikin unit ventilators on any of three levels:

- As stand-alone units, with control either at the unit or from a wall sensor.
- Controlled as part of a network using a centralized building automation system.
- In a-client-server relationship, where client units follow the server unit for some or all functions.

Stand-Alone Control

When operating in stand-alone mode, the MicroTech controller performs complete room temperature and ventilation control. Units can be operated in occupied, unoccupied, stand-by, or bypass (tenant override) modes. Occupied/unoccupied changeover can be accomplished:

- Automatically by an internal Daily Schedule (two occupied times and two unoccupied times for each of the seven days, and one holiday schedule)

- Using a field-wired occupancy sensor.

If a school has more than one zone, separate, internally-programmed schedules are used to regulate each zone.

Client-Server Control

Designate the server and client units and we will factory configure and install the controllers so they are set up for a local peer-to-peer network between units (leaving only the network wiring between these units to be field installed).

Client units can be field-configured to be dependent or independent as follows:

- Dependent client units follow the server unit completely. They are ideal for large spaces that have even loads across the space (such as some libraries).
- Independent client units (default) use server setpoints and client sensors. The client follows the server unit modes, such as heat or cool, but has the flexibility to provide the conditioning required for its area within the space. Independent client units perform better in spaces where loads vary from one area of the space to the other (such as stairwells or cafeterias).

Network Control

MicroTech unit controllers provide easy integration into your building automation system of choice. All factory-installed options are handled by the unit controller. This simplifies the transmission of monitoring and setpoint data to the building automation system.

MicroTech controls have on-board BACnet communication, with optional LONTALK, to communicate control and monitoring information to your BAS, without the need for costly gateways (see "[Communication Types](#)" on page 68).

Flexible network communication options via our Protocol Selectability feature help you avoid control obsolescence over the life of your Daikin equipment.

USB Interface

An optional USB-A port can be factory-configured. This option simplifies field access to the MicroTech controller. The USB interface can be used for downloading code, changing unit configuration, accessing external memory, or a field-connection to run the service tool. Technicians will have access to read all inputs, download code, setup/download trend data, and backup, restore, or change unit configuration.

SD Card

An optional SD card can be factory configured. The SD card allows storage of data trending and configuration parameters. For further details see [page 72](#).

Economizer Modes

Economizer operation is facilitated by the outdoor air damper, which automatically adjusts the above-minimum outside air position to provide free cooling when the outdoor air temperature is appropriate. Three levels of economizer control are available:

Basic Economizer Operation: The MicroTech controller compare the inside and outside temperatures. If the temperature comparison is satisfactory, then free- air economizer operation is used to cool the space. Reheat units also come configured with an indoor humidity sensor.

Expanded Economizer Operation: In addition to comparing inside and outside temperatures, outdoor relative humidity is measured to calculate outside air enthalpy. If the enthalpy set point is not exceeded, and the temperature comparison is satisfactory, then free economizer operation is used to cool the space. This helps to minimize the entrance of humid outside air.

Leading-Edge Economizer Operation: The MicroTech controller compare both indoor and outdoor temperatures and indoor and outdoor relative humidities. Then it calculates both inside and outside air enthalpy to determine if free economizer operation can cool the space with non-humid outside air. This is a true enthalpy economizer—a first for unit ventilators.

Demand Control Ventilation

The optional unit mounted, single beam absorption infrared gas sensor has a sensing range of 0 – 2000 ppm and voltage output of 0 to 10 VDC (100 ohm output impedance). The pitot tube sensing device is located in the unit ventilator's return air stream. The optional CO₂ sensor is used with the UVC's Demand Control Ventilation feature to vary the amount of outside air based on actual room occupancy. With network applications, the unit mounted sensor can be overridden by a remote sensor through the network.

Figure 17: Optional CO₂ Sensor



End Panels

Daikin end panels and sub-bases can be used to match up Daikin Applied unit ventilators with existing furniture or units, or with field-supplied storage, sink and bubbler cabinet offerings

One-inch end panels (Figure 18) are typically used to finish off stand-alone floor units. Six-inch end panels, with kick plates, can be used to provide extra space needed for piping (Figure 19). All end panels are individually wrapped in plastic and boxed to help prevent damage during construction.

Figure 18: 1" End Panel

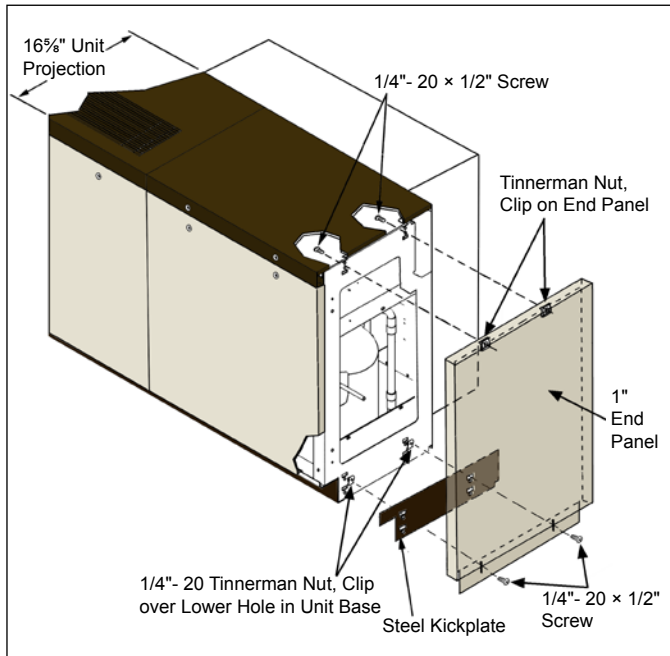
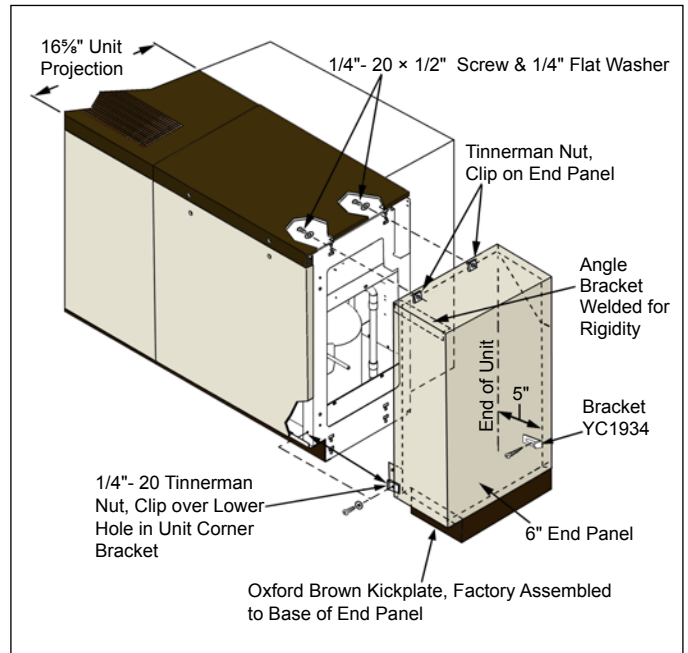
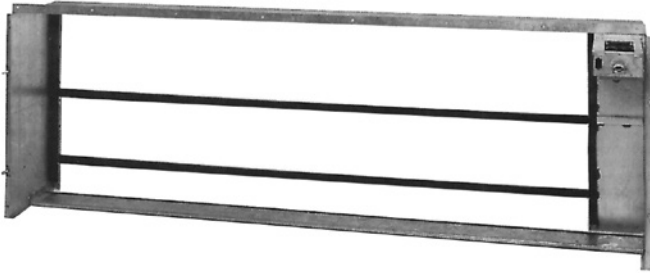

Figure 19: 6" End Panel



Wall Sleeves



The Daikin wall sleeve and louver design is based on a "wet sleeve" concept. In brief, this means the design accommodates the penetration of some moisture into the rear outdoor section of the AEQ unit with provisions for containment and disposal of this moisture to the outdoors. Therefore, proper Louver, Splitter and Wall Sleeve installation is critical.

The wall sleeve must be installed before the AE self-contained unit ventilator can be placed. The recessed portion of the wall sleeve measures approximately 84", 96" or 108" wide by 28" high and may be recessed into

the wall up to 11³/₈" in depth. Consult approved Daikin Applied submittal drawings for the job to determine the proper amount of recess, if any, and recommended wall opening size.

The AEQ unit chassis attaches to the wall sleeve threaded studs using 4-nuts and washers.

Table 1: Wall Sleeve Dimensions for Figure 20

Unit Size	Overall Length "L" (mm)	Sleeve Recess Length "Lr" (mm)
024	86 (2184)	84 (2145)
036	98 (2489)	96 (2450)
044, 054	110 (2794)	108 (2755)

Table 2: Recommended Rough-In Wall Opening

Unit Size	Recommended Wall Opening	
	Length (mm)	Height (mm)
024	84 ¹ / ₂ " (2146)	28 ¹ / ₂ " (724)
036	96 ¹ / ₂ " (2451)	
044, 054	108 ¹ / ₂ " (2756)	

Figure 20: Wall Sleeve Details (Recessed Type Shown)

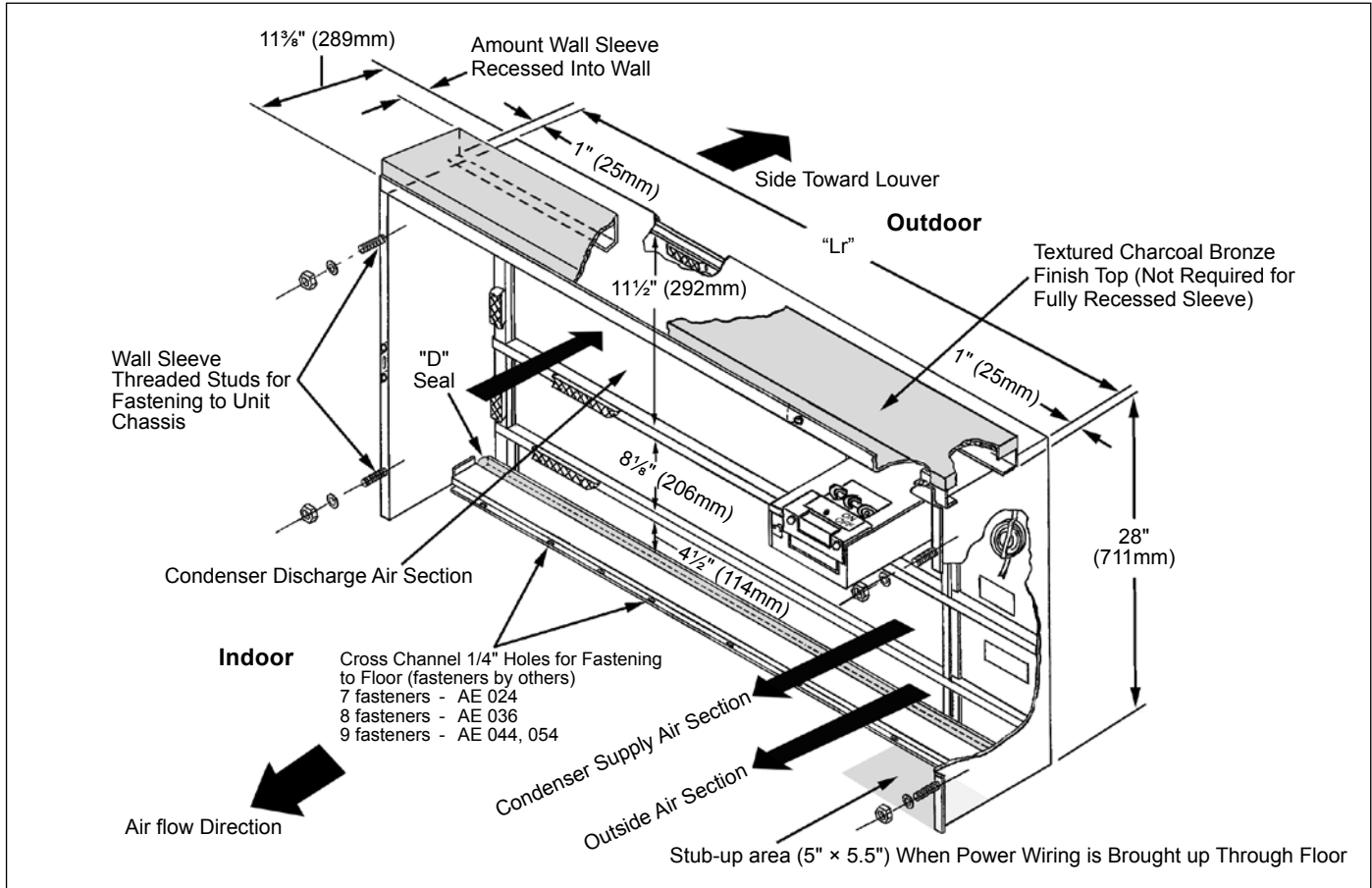

Wall Louvers & Grilles

The louver frame is divided in half horizontally, with make-up and discharge-air stream sections to reduce air recirculation within the vertical louver blade. The upper half of the louver has a blockoff on the exterior side to increase discharge air velocity and improve the throw of leaving air.

The vertical louver can be ordered with flanges that are attached on the outside of all four sides of the louver, resulting in a vertical dimension of 30" (762 mm). Weep holes exist behind the bottom flange of the louver. A diamond pattern expanded aluminum wire mesh (bird screen) is provided on the interior surface of the louver.

The vertical louver is fabricated from 6063-T5 aluminum. The single piece blade has a turned edge along the entering and leaving surface to reduce visibility of the outdoor coil and fan section, and adds rigidity to the blade. The 72-degree offset bend near the middle of the blade creates an air-path turn that minimizes moisture carryover, with a total blade depth of 2¼" (57 mm) in direction of airflow.

Figure 21: Typical Wall Louver and Grille

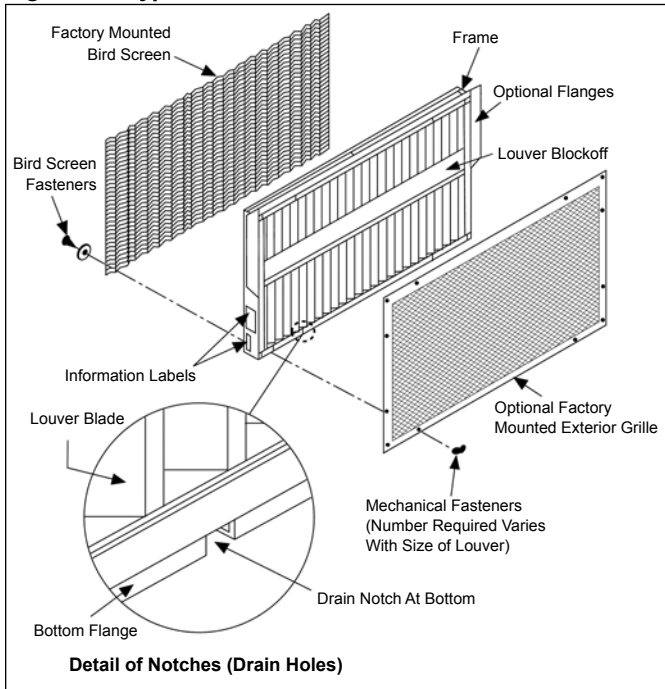

The louver is available in the following colors:

- Natural Aluminum finish (paintable 6063-T5 Aluminum)
- Autumn Brown - thermosetting urethane powder coat paint electrostatically applied and oven-cured to provide correct chemical cross-linking.
- Dark Bronze - thermosetting urethane powder coat paint electrostatically applied and oven-cured to provide correct chemical cross-linking.
- Clear Anodized Aluminum finish

Figure 22: Vertical Blade Louver Outside View, without Flange

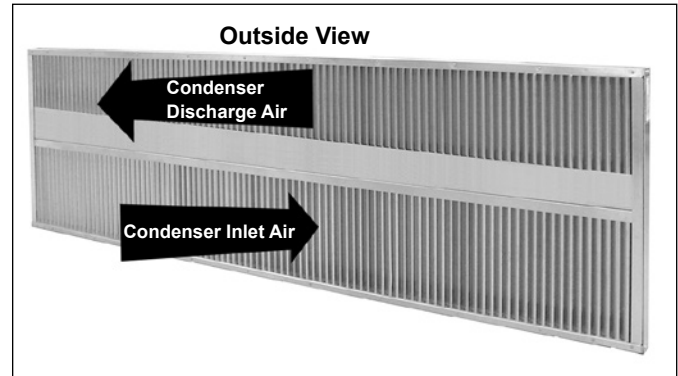
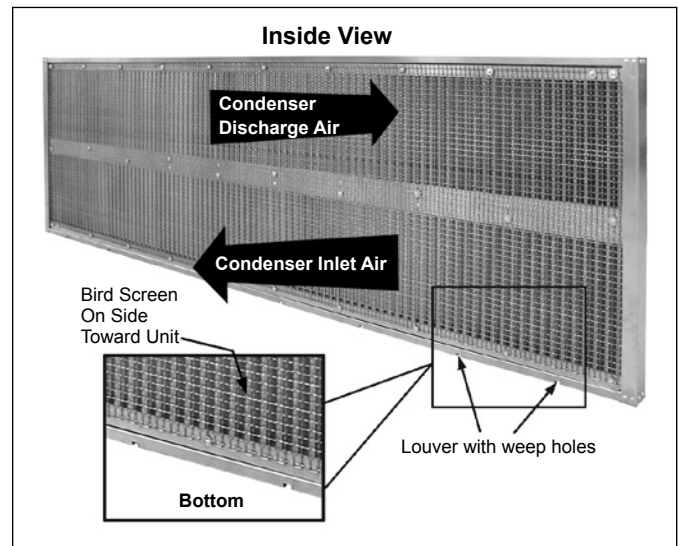

Figure 23: Vertical Blade Louver Inside View, without Flange



VentiMatic™ Shutter Room Exhaust Ventilation

Outdoor air introduced by the unit ventilator must leave the room in some way. In some states, exhaust vents are required by law or code to accomplish this. The VentiMatic Shutter is a more economical solution to the problem.

- The VentiMatic shutter is a continuously variable, gravity-actuated room exhaust vent (Figure 24). It operates in direct response to positive static air pressure created when ventilation air is brought into the room by the unit ventilator. It is a “one-way” shutter that opposes any flow of air into the room.

The VentiMatic Shutter’s ability to exhaust only the amount of air required results in considerable energy savings. In the heating mode, the unit ventilator will be able to bring in only the required percent minimum outdoor air. Unlike systems that rely on powered exhaust, no energy will be wasted heating excess outdoor air. In the cooling mode, the unit ventilator will be able to bring in 100% outdoor air for full natural or free cooling when it is energy effective.

Since it is not powered, VentiMatic Shutter operation is inherently silent. Unlike other non-powered vents, it opens at an extremely low positive pressure (0.005”). Its shutter flaps are made of temperature-resistant glass fabric impregnated with silicone rubber for flexibility and long life. This fabric retains its original properties down to -50°F.

Figure 24: VentiMatic Shutter

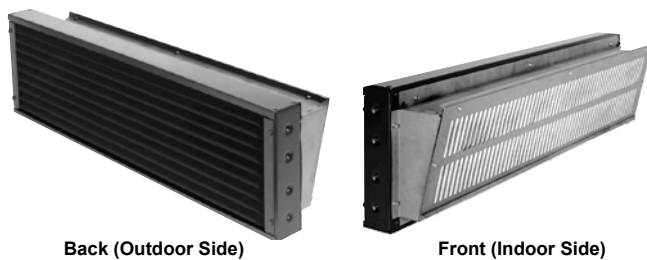

Physical Data

Table 3: AEQ General Data

			024	036	044	054
Fan Data	Nominal CFM (L/s)	High Speed	1000 (472)	1250 (590)	1500 (708)	1500 (708)
		Medium speed	750 (354)	1000 (472)	1150 (543)	1150 (543)
		Low Speed	650 (307)	800 (378)	950 (448)	950 (448)
	Number of Fans		3	4	4	4
	Size	Diameter - in (mm)	8.12 (206mm)	8.12 (206mm)	8.12 (206mm)	8.12 (206mm)
		Width- in (mm)	8.25 (210mm)	8.25 (210mm)	8.25 (210mm)	8.25 (210mm)
Fan Motors	Room Fan Motor Horsepower (Type)		1/4 (PSC)	1/4 (PSC)	1/4 (PSC)	1/3 (ECM)
	Outdoor Fan Horsepower (Type)		1/3 (PSC)	3/4 (ECM)	3/4 (ECM)	3/4 (ECM)
Filter Data	Nominal Size	Inches	10 × 48½ × 1	10 × 60½ × 1	(2) 10 × 36½ × 1	(2) 10 × 36½ × 1
		(mm)	254 × 1232 × 25	254 × 1537 × 25	(2) 254 × 927 × 25	(2) 254 × 927 × 25
	Area - Ft2 (m²)		3.37 (.31)	4.2 (.39)	5.08 (.47)	5.08 (.47)
	Quantity		1	1	2	2
Shipping Weight	Lb. (kg)		885 (402)	975 (442)	1075 (448)	1075 (448)
Refrigerant Charge	Oz.		146	158	166	142

Model AEQ Self-Contained Unit Dimensions – Size 024

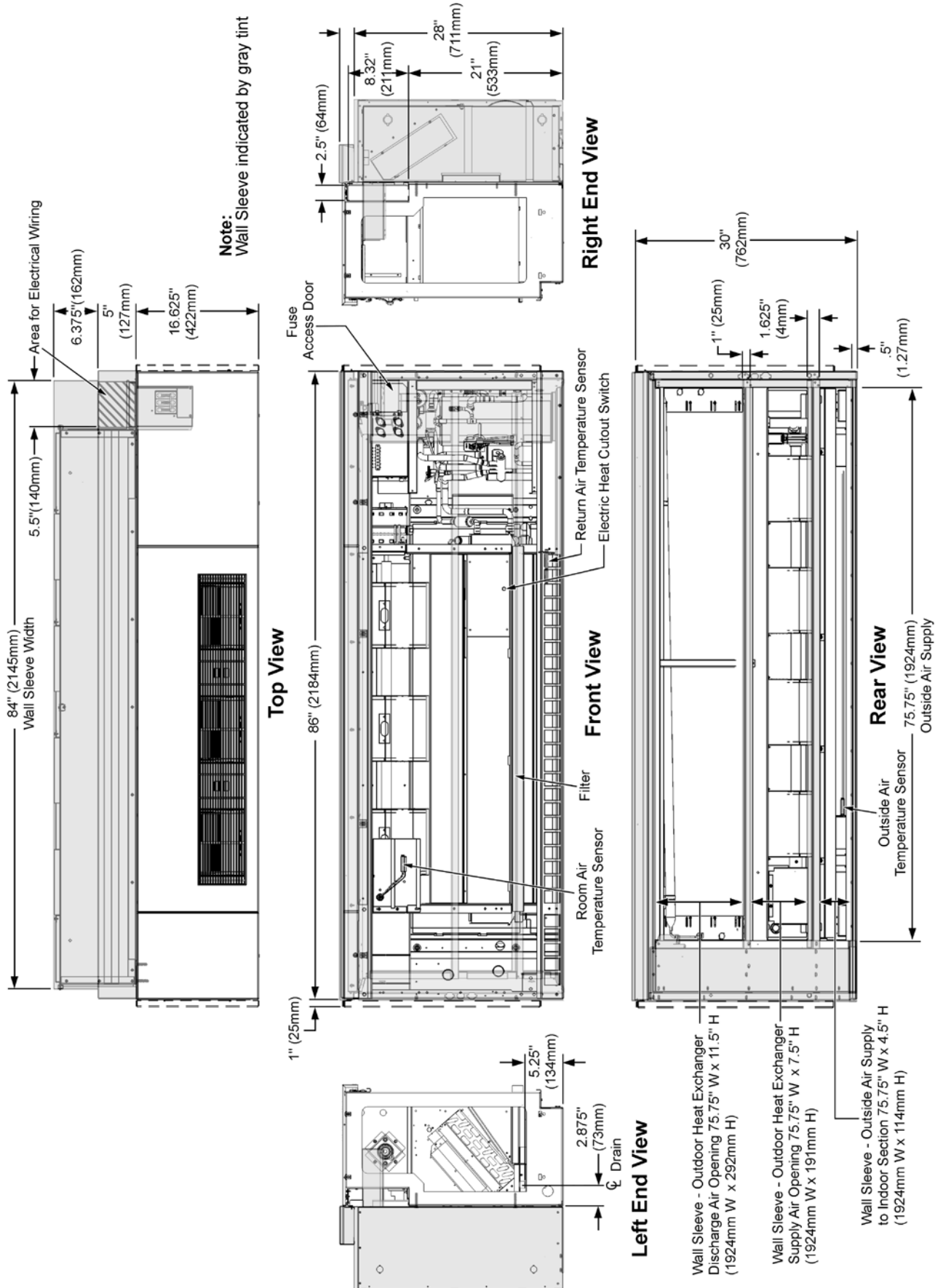

Model AEQ Self-Contained Unit Dimensions – Size 036

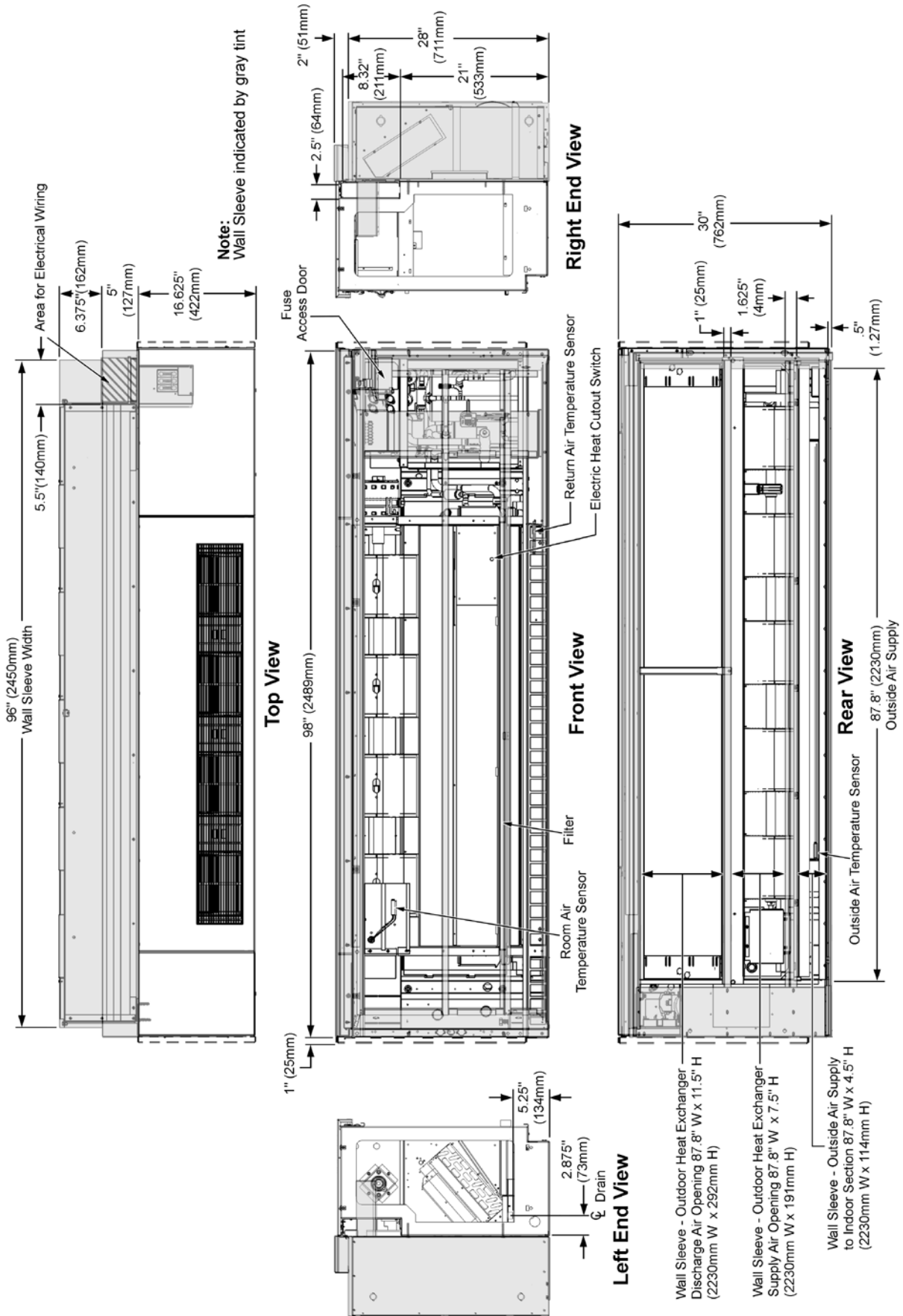

Model AEQ Self-Contained Unit Dimensions – Sizes 044, 054

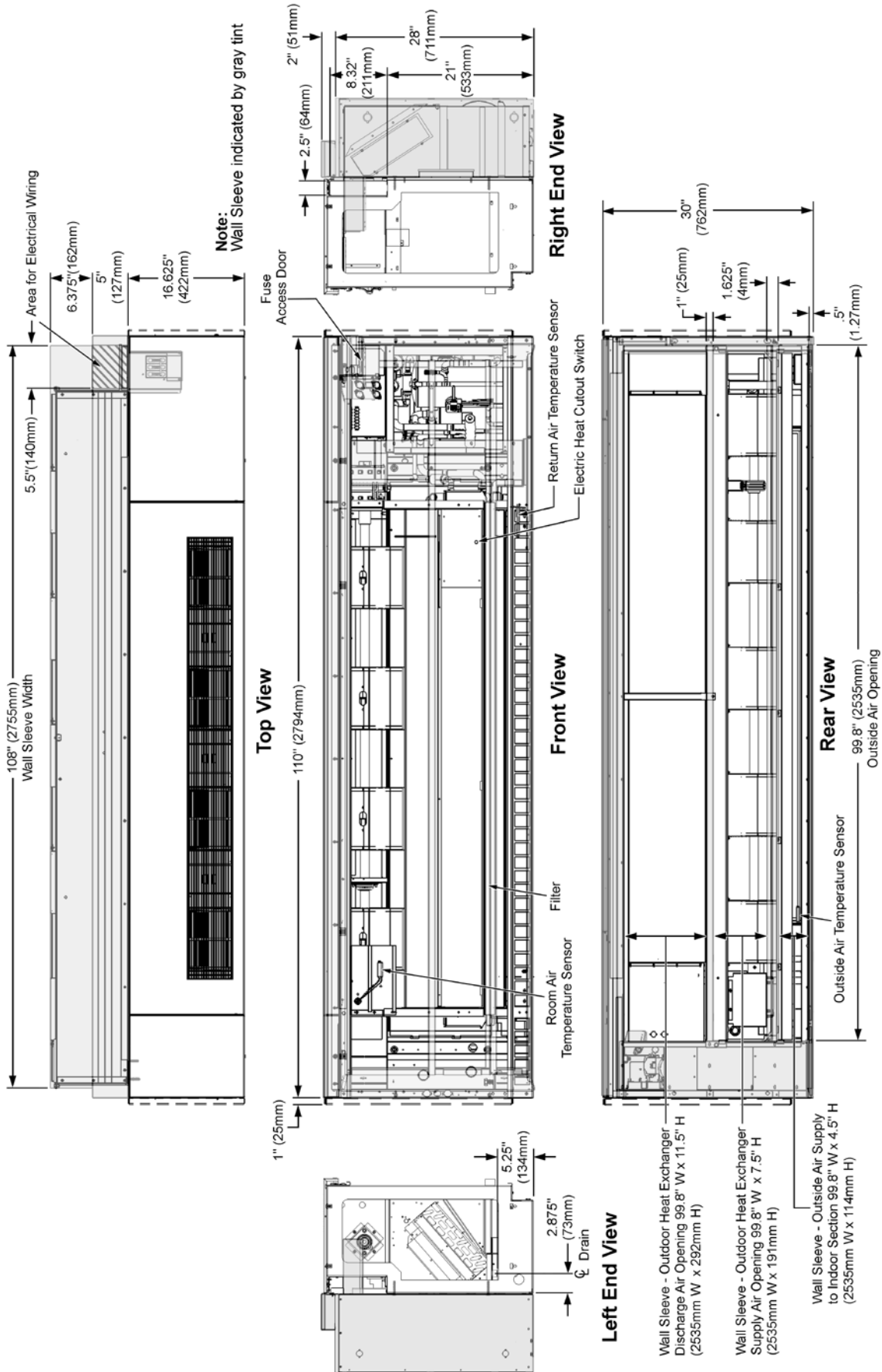

End Panels

Figure 25: 1" (25mm) End Panel Dimensions

All Dim. in inches	16 ⁵ / ₈ " (422mm) Deep End Panels	19 ⁵ / ₈ " (498mm) Deep End Panels	21 ⁷ / ₈ " (556mm) Deep End Panels	28" (711mm) Deep End Panels
Top View				
End View with No Cut-Out				

Figure 26: 6" (152mm) End Panel Dimensions

Top View				
End View with No Cut-Out				

Wall Intake Louvers & Grilles

Louvers are available with a vertical blade configuration, constructed of heavy-gauge (unpainted, painted, or clear anodized) aluminum.

- The louver is divided in half horizontally to prevent condenser air recirculation.
- A bird screen is provided on the leaving air side of the intake louver.
- Louvers can be supplied with or without flanges:
- Flanged louvers are typically used for a panel wall finish.
- Unflanged louvers are typically used for recessing into a masonry wall.
- An optional (factory-mounted) heavy-duty lattice exterior grille is available with horizontal and vertical lines that “line up” with the louver blades to present an aesthetic appearance.
- Louvers are available in both horizontal and vertical blade configurations:

Figure 27: Typical Wall Louver and Grille

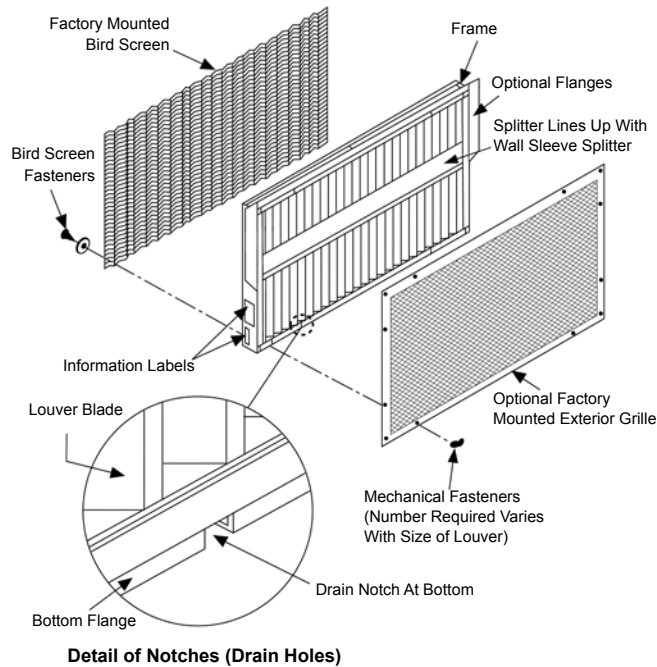

Figure 28: Vertical Blade Louver, Without Flange

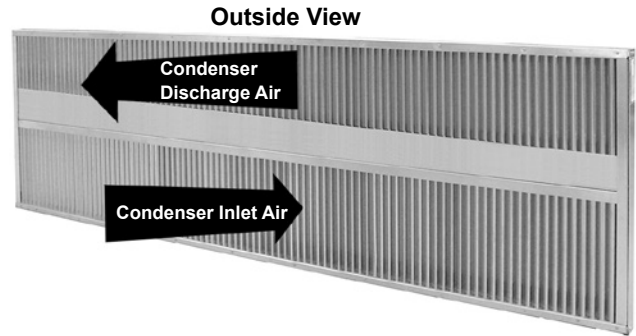

Figure 29: Grille Detail

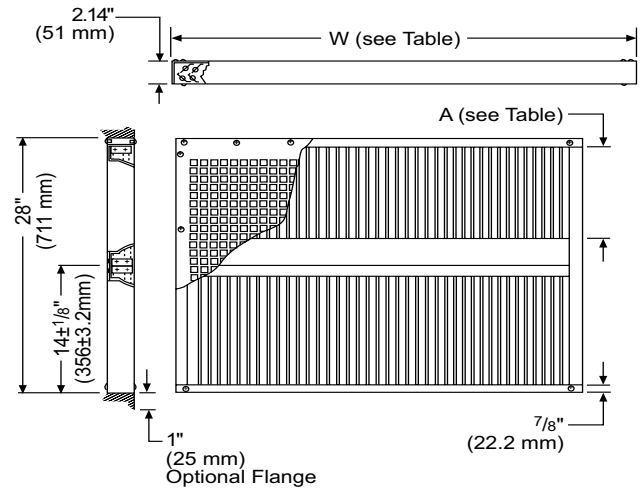
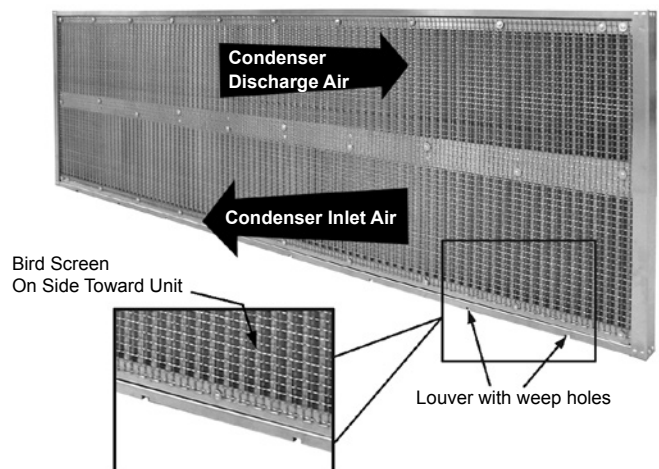

Table 4: Wall Louver Dimensions (W)

Unit Size	Louver Size (Height x W)	Discharge Air Opening (A)
024	28" × 84" (711 × 2134)	9" (229mm)
036	28" × 96" (711 × 2438)	9" (229mm)
044, 054	28" × 108" (711 × 2743)	7" (178mm)

Note: All dimensions are approximate and subject to change without notice. Refer to approved submittal prints for rough-in details and construction purposes, and for recommended wall opening size.

Figure 30: Vertical Blade Louver, without Flange
Inside View



VentiMatic Shutter Assembly

Notes:

- 1 Horizontal blade louver shown. Vertical blade louver also available with Ventimatic shutter.
- 2 Optional exterior grille matches unit ventilator louver in material and design. Mounted in wall louver.
- 3 Optional interior grille mounting hardware is not included.
- 4 Louver leaves seal against plate to prevent air infiltration.

Figure 31: VentiMatic Shutter Assembly with Optional Grille

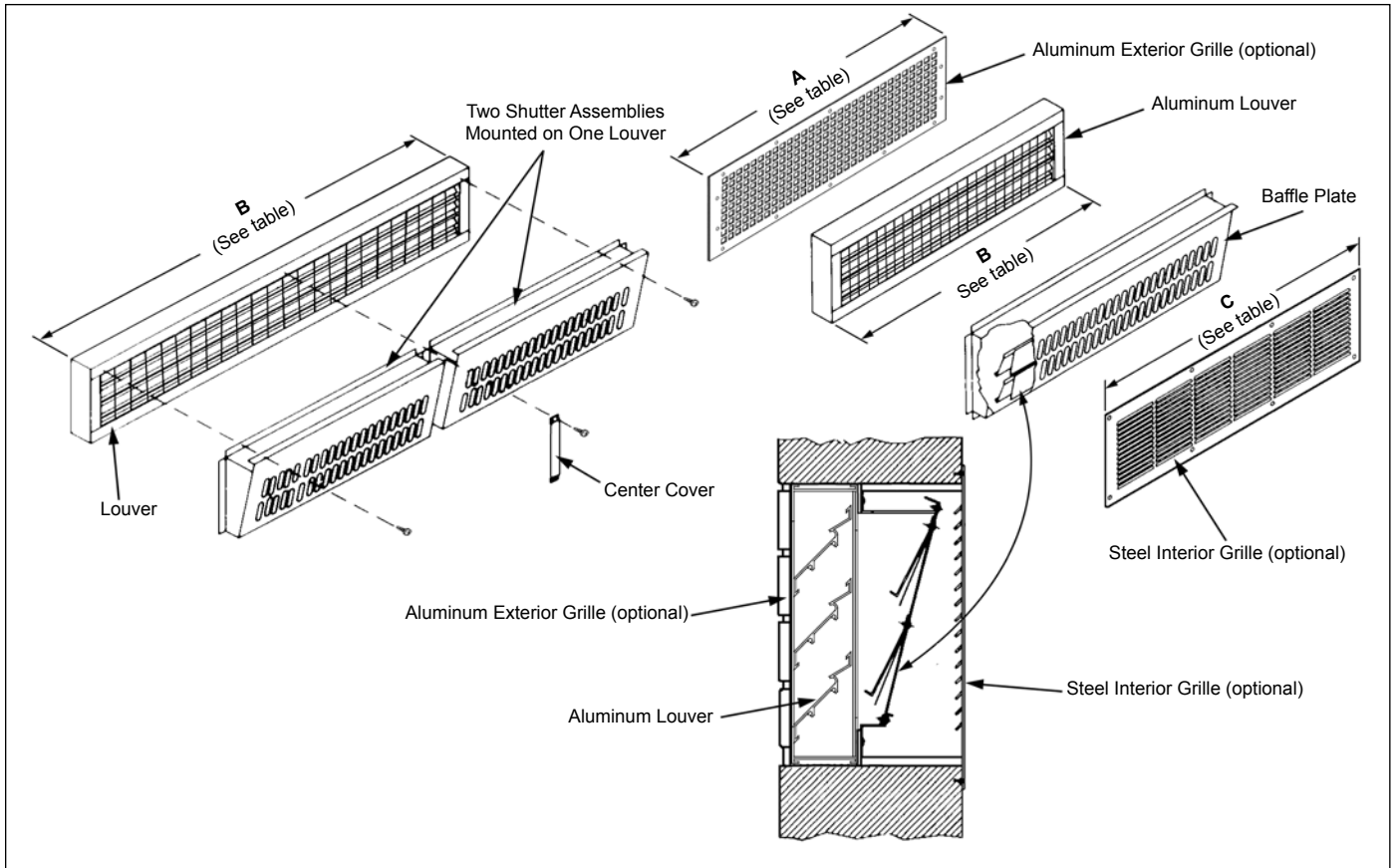

Table 5: VentiMatic Shutter Assembly Dimensions & Maximum Air Capacities

Exterior Grille "A"		Louver Width "B"		Interior Grille Width "C"		Recommended Wall Opening For Shutter				Max. Number of VentiMatic Shutters to Mount on Standard Louver		VentiMatic Shutter(s) Max. Air Capacity	
inches	mm	inches	mm	inches	mm	Length		Width		24" (610mm) Shutter	36" (914mm) Shutter	CFM	L/s
						inches	mm	inches	mm				
23¾	603	24	610	27	686	24¾	616	10½	267	1	0	500	236
36¾	933	36	914	39	991	36¾	921			0	1	750	354
47¾	1213	48	1219	51	1295	48¾	1225			2	0	1000	472
59¾	1518	60	1524	63	1600	60¾	1530			1	1	1250	590
71¾	1822	72	1829	75	1905	72¾	1835			0	2	1500	708

Quick Selection Procedure

The following procedure will provide you with a rough determination of unit capacity for cooling and/or heating based on the number of coil rows. Use capacity tables for final selection. Consult your local Daikin representative for details on the computer selection programs Daikin Applied provides for this purpose.

Table 6: Cooling Capacity Selection Table

Unit Size	Compressor Capacity	Fan Speed	Nominal Airflow		Total Capacity	Sensible Capacity	Efficiency	Outdoor Temp
			CFM	L/s	Btuh	Btuh	EER	DB / WB
024	Full	High	1000	472	21000	16400	9.7	95/75
	Part	Med	750	354	17300	12800	12.4	82/65
	Part	Low	650	307	16900	11800	12.7	82/65
036	Full	High	1250	590	40000	25900	10.4	95/75
	Part	Med	1000	472	30200	19500	12.3	82/65
	Part	Low	800	378	28600	17500	11.9	82/65
044	Full	High	1500	708	43500	29600	10.0	95/75
	Part	Med	1050	496	33300	22300	12.3	82/65
	Part	Low	850	378	31600	20100	11.5	82/65
054	Full	High	1500	708	52000	33800	10.2	95/75
	Part	Med	1050	496	33400	21900	11.5	82/65
	Part	Low	800	378	30200	18600	10.2	82/65

Note: Cooling Conditions: Indoor 80°F db/67°F wb

Table 7: Heating Capacity Selection Table

Unit Size	Compressor Capacity	Fan Speed	Nominal Airflow		Total Capacity	Efficiency	Outdoor Temp
			CFM	L/s	Btuh	COP	DB / WB
024	Full	High	1000	472	19500	3.0	47/43
	Part	Med	750	354	18000	3.5	62/56.5
	Part	Low	650	307	17700	3.4	62/56.5
036	Full	High	1250	590	36100	2.9	47/43
	Part	Med	1000	472	29100	2.7	62/56.5
	Part	Low	800	378	27700	2.5	62/56.5
044	Full	High	1500	708	42500	2.9	47/43
	Part	Med	1050	496	36400	3.0	62/56.5
	Part	Low	850	378	35400	2.8	62/56.5
054	Full	High	1500	708	52300	2.9	47/43
	Part	Med	1050	496	36100	2.7	62/56.5
	Part	Low	800	378	33700	2.3	62/56.5

Note: Heating Conditions: Indoor 80°F db/67°F wb

Selection Procedure

Step 1: Determine Design Conditions

Determine design indoor and outdoor air temperatures in accordance with established engineering practices, as outlined in the ASHRAE Guide or other authoritative source. Indoor temperatures of 80°F dry bulb, 67°F wet bulb for summer and 70°F dry bulb for winter usually are acceptable for design or peak load conditions, even though the expected operating conditions of the system may be somewhat different.

Step 2: Determine Heating and Cooling Loads

Calculate design winter heating losses and summer cooling loads in accordance with the procedures outlined by the ASHRAE Guide or other authoritative source. Perhaps the greatest consideration in calculating design loads is solar heat gain. August solar heat values might be used for summer cooling loads, but should not be used for ventilation air or “natural cooling” capacity calculations; since these cooling loads reach their maximum in the spring and autumn months. The natural cooling capacity is usually calculated for 55° or 60°F outdoor air temperature.

Table 8: Outdoor Air Ventilation Sensible Cooling Capacities Based On 75°F Room Temperature

Unit Series	Nominal CFM	Outdoor Air Temperature	
		55°F	60°F
024	1000	21.7 MBH	16.3 MBH
036	1250	27.1 MBH	20.3 MBH
044, 054	1500	32.6 MBH	24.4 MBH

Step 3: Determine Air Quantity Required

Air quantity for heating applications is determined from circulation of a definite number of room air volumes per hour. Table 9 gives the recommended number of room air changes per hour.

Table 9: Recommended Room Air Changes Per Hour

Type of Space	Recommended Number of Room Air Changes Per Hour
Classrooms, Offices	6 to 9
Laboratories, Shops	6 to 8
Cafeterias & Kitchens	4½ to 7

For rooms facing east, south or west, the higher values shown in the table should be used so adequate ventilation cooling will be available to prevent overheating during mild sunny weather. The following equation is helpful to determine the CFM air delivery for any given rate of circulation:

Equation 1: CFM For Given Rate Of Circulation

$$\frac{\text{Room Volume (cu ft)} \times \text{Room Changes per Hour}}{60} = \text{CFM}$$

In mechanical cooling applications, the total air quantity may be determined or verified by use of the sensible cooling load equation:

Equation 2: CFM Based On Sensible Cooling Load

$$\text{CFM} = \frac{Q \text{ sensible (space)}}{1.086 \times \text{TD}}$$

Q sensible is the maximum sensible room load and T.D. is the temperature difference between the room design dry bulb temperature and the final or leaving-air dry bulb temperature. For these calculations, a T.D. of 20°F is usually assumed to be desirable to avoid delivering air too cold for comfort. This figure may be varied one or two degrees for reasons of practicality.

Note: The sensible load used in the preceding equation is the space load and excludes the ventilation load.

Most areas have ventilation codes which govern the amount of ventilation air required for school applications. For other than school applications or areas not having codes, the ASHRAE Guide may be used for authoritative recommendations and discussion of the relation between odor control and outdoor air quantities.

The minimum outdoor air quantity recommended by ASHRAE for K-12 classrooms is 10 CFM per person plus 0.12 CFM/ft². Lower percent minimum outdoor air settings are more economical. In the interest of economy, it may be desirable to use lower percent minimums if there are no ventilation codes.

Step 4: Select Unit Size

The unit should be selected to meet or exceed the CFM delivery requirement previously determined. All model types are available with nominal capacities of 1000, 1250 and 1500 CFM. Unit sizes 024, 036, 044 and 054.

Cooling Capacity

Unit cooling capacity should be selected to equal or slightly exceed the sum of computed room sensible and latent heat gains (Room Total Capacity). When operating on the mechanical cooling cycle, the control system introduces a constant amount of outdoor air for ventilation. The latent and sensible heat gain from this outdoor ventilation air must be added to the room total cooling load before choosing the proper capacity unit.

Heating Capacity

Unit heating capacity should be selected to equal or slightly exceed the computed room heat loss. For units installed for 100% recirculation, it is good practice to increase the heating capacity by 15% to aid in quick room warm-up. This allowance is unnecessary for units delivering a minimum outdoor air of 20% or more, since the outdoor air damper remains closed until the room is up to temperature. The heat normally expended in heating the minimum-percent outdoor air up to room temperature is available for quick warm-up purposes.

The heating required to warm the outdoor ventilating air up to room temperature must also be calculated. The Total Capacity should be used in sizing, piping, boilers, etc.

Step 5: Freeze Protection

Constant pump operation is required whenever the outdoor air temperature is below 35°F. This will assist in providing protection against freeze up of the system water piping and coils.

Cooling Selection Example

Step 1: Determine Design Conditions

Assume the following design indoor and outdoor air temperatures are given:

- Outdoor design temperature = 96°F DB / 74°F WB
- Room design temperature = 76°F DB / 65°F WB

Step 2: Determine Cooling Loads

Assume the following cooling loads are given:

- Minimum total capacity (TC) = 37.8 MBH
- Minimum sensible capacity (SC) = 23.9 MBH
- Minimum outdoor air = 20%
- Room volume = 9,000 cubic feet
- Desired number of air changes per hour = 8

Step 3: Determine Air Quantity Required

"Equation 1: CFM For Given Rate Of Circulation" on page 30 indicates that to obtain eight room volumes per hour, a unit capable of delivering 1200 CFM standard air must be used, as follows:

$$\text{CFM} = \frac{(\text{Room Volume Ft}^3) \times (\text{Room Changes per Hour})}{80}$$

$$\text{CFM} = \frac{9000 \times 8}{60} = 1200$$

This indicates that a size 036 Unit Ventilator should be used, which delivers 1250 CFM.

Step 4: Select Unit Size

Determine the unit performance as follows:

Determine Entering Dry Bulb Temperature

The entering dry bulb (EDB) temperature is calculated using the following formula:

$$\text{EDB} = \text{Room DB} \times \frac{\% \text{RA}}{100} + \text{Outdoor DB} \times \frac{\% \text{OA}}{100}$$

$$\text{EDB} = 76(0.8) + (96)(0.2) = 80^\circ\text{F}$$

Determine Entering Wet Bulb Temperature

The entering wet bulb (EWB) temperature is determined by calculating the Enthalpy (H) at saturation, then looking up the corresponding EWB (Table 10 on page 32). Enthalpy (H) is calculated as follows:

$$\text{Enthalpy (H)} = \text{Room Enthalpy} \times \frac{\% \text{RA}}{100} + \text{Outdoor Enthalpy} \times \frac{\% \text{OA}}{100}$$

$$\text{Enthalpy (H)} = 30.06 (0.8) + 37.66 (0.2) = 31.58 \text{ btu/lb}$$

Referring to Table 10 on page 32, EWB for 31.58 btu/lb = 67°F

Look Up Capacities

Look up the Total and Sensible cooling capacity for a Size 036 unit at High Fan Speed from "Cooling Capacity Selection Table" on page 29. Interpolation between the values for Outdoor DB = 90°F and 100°F, at Entering Air Temperature DB/WB = 80/67, will yield the following results.

- 39.7 MBH (TC)
- 26.5 MBH (SC)

Leaving air temperatures dry bulb °F (LDB) and wet bulb °F (LWB) may be calculated as follows:

$$\text{LDB} = \text{EDB} - \frac{\text{SC(Btuh)}}{\text{CFM} \times 1.085} = 80 - \frac{26500}{1250 \times 1.085} = 60.4^\circ\text{F}$$

$$\text{LWBH} = \text{EWB} - \frac{\text{TC(Btuh)}}{\text{CFM} \times 4.5} = 31.62 - \frac{39700}{1250 \times 4.5} = 24.6$$

From "Cooling Capacity Selection Table" on page 29:

LWB at 24.6 H = 57.1°F.

Note: Interpolation within each table and between sets of tables for each unit series is permissible.

For conditions of performance beyond the scope of the catalog selection procedures, Daikin offers computer selection programs for cooling, hot water and steam coils. Consult your local Daikin representative for details.

Table 10: Enthalpy (H) at Saturation But Per Pound of Dry Air

Wet Bulb Temp. °F	Tenths of A Degree									
	0	0.1	0.2	0.3	0.4	0.5	0.6	0.7	0.8	0.9
50	20.3	20.36	20.41	20.47	20.52	20.58	20.64	20.69	20.75	20.8
51	20.86	20.92	20.97	21.03	21.09	21.15	21.2	21.26	21.32	21.38
52	21.44	21.5	21.56	21.62	21.67	21.73	21.79	21.85	21.91	21.97
53	22.02	22.08	22.14	22.2	22.26	22.32	22.38	22.44	22.5	22.56
54	22.62	22.68	22.74	22.8	22.86	22.92	22.98	23.04	23.1	23.16
55	23.22	23.28	23.34	23.41	23.47	23.53	23.59	23.65	23.72	23.78
56	23.84	23.9	23.97	24.03	24.1	24.16	24.22	24.29	24.35	24.42
57	24.48	24.54	24.61	24.67	24.74	24.8	24.86	24.93	24.99	25.06
58	25.12	25.19	25.25	25.32	25.38	25.45	25.52	25.58	26.65	25.71
59	25.78	25.85	25.92	25.98	26.05	26.12	26.19	26.26	26.32	26.39
60	26.46	26.53	26.6	26.67	26.74	26.81	26.87	26.94	27.01	27.08
61	27.15	27.22	27.29	27.36	27.43	27.5	27.57	27.64	27.71	27.78
62	27.85	27.92	27.99	28.07	28.14	28.21	28.28	28.35	28.43	28.5
63	28.57	28.64	28.72	28.79	28.87	28.94	29.01	29.09	29.16	29.24
64	29.31	29.39	29.46	29.54	29.61	29.69	29.76	29.84	29.91	29.99
65	30.06	30.14	30.21	30.29	30.37	30.45	30.52	30.6	30.68	30.78
66	30.83	30.91	30.99	31.07	31.15	31.23	31.3	31.38	31.46	31.54
67	31.62	31.7	31.78	31.86	31.94	32.02	32.1	32.18	32.26	32.34
68	32.42	32.5	32.59	32.67	32.75	32.84	32.92	33	33.08	33.17
69	33.25	33.33	33.42	33.5	33.59	33.67	33.75	33.84	33.92	34.01
70	34.09	34.18	34.26	34.35	34.43	34.52	34.61	34.69	34.78	34.86
71	34.95	35.04	35.13	35.21	35.3	35.39	35.48	35.57	35.65	35.74
72	35.83	35.92	36.01	36.1	36.19	36.29	36.38	36.47	36.56	36.65
73	36.74	36.83	36.92	37.02	37.11	37.2	37.29	37.38	37.48	37.57
74	37.66	37.76	37.85	37.95	38.04	38.14	38.23	38.33	38.42	38.52
75	38.61	38.71	38.8	38.9	38.99	39.09	39.19	39.28	39.38	39.47
76	39.57	39.67	39.77	39.87	39.97	40.07	40.17	40.27	40.37	40.47
77	40.57	40.67	40.77	40.87	40.97	41.08	41.18	41.28	41.38	41.48
78	41.58	41.68	41.79	41.89	42	42.1	42.2	42.31	42.41	42.52
79	42.62	42.73	42.83	42.94	43.05	43.16	43.26	43.37	43.48	43.58
80	43.69	43.8	43.91	44.02	44.13	44.24	44.34	44.45	44.56	44.67
81	44.78	44.89	45	45.12	45.23	45.34	45.45	45.56	45.68	45.79
82	45.9	46.01	46.13	46.24	46.36	46.47	46.58	46.7	46.81	46.93
83	47.04	47.16	47.28	47.39	47.51	47.63	47.75	47.87	47.98	48.1
84	48.22	48.34	48.46	48.58	48.7	48.83	48.95	49.07	49.19	49.31
85	49.43	49.55	49.68	49.8	49.92	50.05	50.17	50.29	50.41	50.54

Size 024 (1000 SCFM) – 2nd Stage High Fan

Entering Air Temperature Outdoor DB °F	Entering Air Temperature Indoor DB/WB °F	Cooling				Heating		
		Total Btuh	Sensible Btuh	Power Input kW	EER	Total Btuh	Power Input kW	COP
20	65/55	Operation Not Recommended				12400	1.707	2.13
	70/59					12100	1.786	1.99
	75/63					11800	1.865	1.85
	80/67					11600	1.943	1.75
	85/71					11300	2.022	1.64
30	65/55					15300	1.758	2.55
	70/59					15000	1.836	2.39
	75/63					14700	1.915	2.25
	80/67					14500	1.994	2.13
	85/71					14200	2.072	2.01
40	65/55	20700	15900	1.334	15.5	18000	1.807	2.92
	70/59	22200	16900	1.354	16.4	17700	1.886	2.75
	75/63	23800	17900	1.374	17.3	17500	1.965	2.61
	80/67	25300	18900	1.394	18.1	17200	2.043	2.47
	85/71	26800	19900	1.414	19.0	16900	2.122	2.33
50	65/55	21400	15700	1.424	15.0	20500	1.856	3.24
	70/59	23000	16700	1.445	15.9	20200	1.935	3.06
	75/63	24500	17700	1.465	16.7	20000	2.014	2.91
	80/67	26100	18700	1.485	17.6	19700	2.092	2.76
	85/71	27600	19600	1.505	18.3	19500	2.171	2.63
60	65/55	21500	15400	1.537	14.0	22800	1.904	3.51
	70/59	23100	16400	1.557	14.8	22600	1.983	3.34
	75/63	24600	17300	1.577	15.6	22300	2.062	3.17
	80/67	26100	18300	1.598	16.3	22100	2.140	3.03
	85/71	27700	19300	1.618	17.1	21800	2.219	2.88
70	65/55	20900	14900	1.672	12.5	25000	1.952	3.75
	70/59	22400	15900	1.692	13.2	24700	2.030	3.57
	75/63	24000	16900	1.712	14.0	24500	2.109	3.40
	80/67	25500	17900	1.733	14.7	24200	2.188	3.24
	85/71	27100	18900	1.753	15.5	23900	2.266	3.09
80	65/55	19600	14400	1.829	10.7	27000	1.998	3.96
	70/59	21200	15400	1.849	11.5	26700	2.077	3.77
	75/63	22700	16400	1.870	12.1	26400	2.155	3.59
	80/67	24200	17400	1.890	12.8	26200	2.234	3.44
	85/71	25800	18400	1.910	13.5	25900	2.313	3.28
90	65/55	17600	13800	2.009	8.8	28700	2.044	4.11
	70/59	19200	14800	2.029	9.5	28500	2.123	3.93
	75/63	20700	15800	2.049	10.1	28200	2.201	3.75
	80/67	22200	16800	2.069	10.7	28000	2.280	3.60
	85/71	23800	17700	2.089	11.4	27700	2.359	3.44

Size 024 (1000 SCFM) – 2nd Stage High Fan (Continued)

Entering Air Temperature Outdoor DB °F	Entering Air Temperature Indoor DB/WB °F	Cooling				Heating		
		Total Btuh	Sensible Btuh	Power Input kW	EER	Total Btuh	Power Input kW	COP
100	65/55	15000	13100	2.210	6.8	Operation Not Recommended		
	70/59	16500	14000	2.230	7.4			
	75/63	18000	15000	2.250	8.0			
	80/67	19600	16000	2.270	8.6			
	85/71	21100	17000	2.291	9.2			
110	65/55	11600	12200	2.434	4.8			
	70/59	13100	13200	2.454	5.3			
	75/63	14700	14200	2.474	5.9			
	80/67	16200	15200	2.494	6.5			
	85/71	17800	16200	2.514	7.1			
115	65/55	9700	11800	2.554	3.8			
	70/59	11200	12800	2.574	4.4			
	75/63	12700	13800	2.594	4.9			
	80/67	14300	14700	2.614	5.5			
	85/71	15800	15700	2.634	6.0			

Note: Capacity Data at Full Load

Legend: Btuh = British Thermal Units per Hour
 EER = Energy Efficiency Ratio
 kW = Kilowatt

DB = Dry Bulb
 WB = Wet Bulb

Size 024 (750 SCFM) – 1st Stage Medium Fan

Entering Air Temperature Outdoor DB °F	Entering Air Temperature Indoor DB/WB °F	Cooling				Heating		
		Total Btuh	Sensible Btuh	Power Input kW	EER	Total Btuh	Power Input kW	COP
20	65/55	Operation Not Recommended				9200	1.348	2.00
	70/59					9100	1.417	1.88
	75/63					8900	1.486	1.75
	80/67					8700	1.554	1.64
	85/71					8500	1.623	1.53
30	65/55					11700	1.379	2.49
	70/59					11500	1.447	2.33
	75/63					11300	1.516	2.18
	80/67					11200	1.584	2.07
	85/71					11000	1.653	1.95
40	65/55	18800	13500	1.012	18.6	13900	1.403	2.90
	70/59	19900	14300	1.000	19.9	13800	1.471	2.75
	75/63	21100	15100	0.987	21.4	13600	1.540	2.59
	80/67	22300	15900	0.974	22.9	13400	1.608	2.44
	85/71	23400	16700	0.962	24.3	13300	1.677	2.32
50	65/55	17700	12600	1.078	16.4	16000	1.421	3.30
	70/59	18800	13400	1.065	17.7	15800	1.490	3.11
	75/63	20000	14200	1.053	19.0	15600	1.559	2.93
	80/67	21200	15000	1.040	20.4	15500	1.627	2.79
	85/71	22300	15800	1.027	21.7	15300	1.696	2.64
60	65/55	16500	11800	1.165	14.2	17800	1.436	3.63
	70/59	17700	12600	1.152	15.4	17700	1.505	3.45
	75/63	18800	13400	1.140	16.5	17500	1.573	3.26
	80/67	20000	14200	1.127	17.7	17300	1.642	3.09
	85/71	21200	15000	1.114	19.0	17100	1.711	2.93
70	65/55	15300	11100	1.273	12.0	19500	1.447	3.95
	70/59	16500	11900	1.261	13.1	19300	1.516	3.73
	75/63	17600	12700	1.248	14.1	19100	1.584	3.53
	80/67	18800	13500	1.236	15.2	18900	1.653	3.35
	85/71	20000	14300	1.223	16.4	18800	1.722	3.20
80	65/55	14100	10500	1.403	10.0	20900	1.456	4.21
	70/59	15200	11300	1.391	10.9	20700	1.524	3.98
	75/63	16400	12100	1.378	11.9	20600	1.593	3.79
	80/67	17600	12900	1.365	12.9	20400	1.662	3.60
	85/71	18700	13700	1.353	13.8	20200	1.730	3.42
90	65/55	12700	10000	1.555	8.2	22100	1.463	4.43
	70/59	13900	10800	1.542	9.0	22000	1.531	4.21
	75/63	15100	11600	1.529	9.9	21800	1.600	3.99
	80/67	16200	12400	1.517	10.7	21600	1.669	3.79
	85/71	17400	13200	1.504	11.6	21400	1.737	3.61

Size 024 (750 SCFM) – 1st Stage Medium Fan (Continued)

Entering Air Temperature Outdoor DB °F	Entering Air Temperature Indoor DB/WB °F	Cooling				Heating		
		Total Btuh	Sensible Btuh	Power Input kW	EER	Total Btuh	Power Input kW	COP
100	65/55	11400	9500	1.727	6.6	Operation Not Recommended		
	70/59	12500	10300	1.715	7.3			
	75/63	13700	11200	1.702	8.0			
	80/67	14900	12000	1.689	8.8			
	85/71	16100	12800	1.677	9.6			
110	65/55	10000	9200	1.921	5.2			
	70/59	11100	10000	1.909	5.8			
	75/63	12300	10800	1.896	6.5			
	80/67	13500	11600	1.884	7.2			
	85/71	14600	12400	1.871	7.8			
115	65/55	9200	9100	2.026	4.5			
	70/59	10400	9900	2.014	5.2			
	75/63	11600	10700	2.001	5.8			
	80/67	12700	11500	1.989	6.4			
	85/71	13900	12300	1.976	7.0			

Note: Capacity Data at Full Load

Legend: Btuh = British Thermal Units per Hour
 EER = Energy Efficiency Ratio
 kW = Kilowatt

DB = Dry Bulb
 WB = Wet Bulb

Size 024 (650 SCFM) – 1st Stage Low Fan

Entering Air Temperature Outdoor DB °F	Entering Air Temperature Indoor DB/WB °F	Cooling				Heating		
		Total Btuh	Sensible Btuh	Power Input kW	EER	Total Btuh	Power Input kW	COP
20	65/55	Operation Not Recommended				9100	1.366	1.95
	70/59					8900	1.435	1.82
	75/63					8800	1.505	1.71
	80/67					8600	1.575	1.60
	85/71					8400	1.644	1.50
30	65/55					11500	1.396	2.41
	70/59					11300	1.466	2.26
	75/63					11200	1.535	2.14
	80/67					11000	1.605	2.01
	85/71					10800	1.675	1.89
40	65/55					18300	12500	0.967
	70/59	19500	13200	0.955	20.4	13600	1.490	2.67
	75/63	20600	13900	0.943	21.8	13400	1.560	2.52
	80/67	21700	14700	0.931	23.3	13200	1.629	2.37
	85/71	22900	15400	0.919	24.9	13100	1.699	2.26
50	65/55	17300	11600	1.030	16.8	15700	1.440	3.19
	70/59	18400	12400	1.018	18.1	15600	1.509	3.03
	75/63	19500	13100	1.006	19.4	15400	1.579	2.86
	80/67	20700	13900	0.994	20.8	15200	1.648	2.70
	85/71	21800	14600	0.982	22.2	15100	1.718	2.58
60	65/55	16100	10900	1.113	14.5	17600	1.455	3.54
	70/59	17300	11600	1.101	15.7	17400	1.524	3.35
	75/63	18400	12400	1.089	16.9	17200	1.594	3.16
	80/67	19600	13100	1.077	18.2	17100	1.663	3.01
	85/71	20700	13900	1.065	19.4	16900	1.733	2.86
70	65/55	15000	10200	1.217	12.3	19200	1.466	3.84
	70/59	16100	11000	1.205	13.4	19000	1.535	3.63
	75/63	17200	11700	1.193	14.4	18800	1.605	3.43
	80/67	18400	12500	1.181	15.6	18700	1.675	3.27
	85/71	19500	13200	1.169	16.7	18500	1.744	3.11
80	65/55	13700	9700	1.341	10.2	20600	1.475	4.09
	70/59	14900	10400	1.329	11.2	20400	1.544	3.87
	75/63	16000	11200	1.317	12.1	20200	1.614	3.67
	80/67	17200	11900	1.305	13.2	20100	1.683	3.50
	85/71	18300	12600	1.293	14.2	19900	1.753	3.33
90	65/55	12400	9200	1.486	8.3	21800	1.482	4.31
	70/59	13600	9900	1.473	9.2	21600	1.551	4.08
	75/63	14700	10700	1.461	10.1	21500	1.621	3.89
	80/67	15900	11400	1.449	11.0	21300	1.690	3.69
	85/71	17000	12200	1.437	11.8	21100	1.760	3.51

Size 024 (650 SCFM) – 1st Stage Low Fan (Continued)

Entering Air Temperature Outdoor DB °F	Entering Air Temperature Indoor DB/WB °F	Cooling				Heating		
		Total Btuh	Sensible Btuh	Power Input kW	EER	Total Btuh	Power Input kW	COP
100	65/55	11100	8800	1.651	6.7	Operation Not Recommended		
	70/59	12300	9500	1.639	7.5			
	75/63	13400	10300	1.626	8.2			
	80/67	14500	11000	1.614	9.0			
	85/71	15700	11800	1.602	9.8			
110	65/55	9700	8500	1.836	5.3			
	70/59	10900	9200	1.824	6.0			
	75/63	12000	10000	1.812	6.6			
	80/67	13200	10700	1.800	7.3			
	85/71	14300	11500	1.788	8.0			
115	65/55	9000	8400	1.937	4.6			
	70/59	10200	9100	1.924	5.3			
	75/63	11300	9900	1.912	5.9			
	80/67	12400	10600	1.900	6.5			
	85/71	13600	11400	1.888	7.2			

Note: Capacity Data at Full Load

Legend: Btuh = British Thermal Units per Hour

EER = Energy Efficiency Ratio

kW = Kilowatt

DB = Dry Bulb

WB = Wet Bulb

Size 036 (1250 SCFM) – 2nd Stage High Fan

Entering Air Temperature Outdoor DB °F	Entering Air Temperature Indoor DB/WB °F	Cooling				Heating		
		Total Btuh	Sensible Btuh	Power Input kW	EER	Total Btuh	Power Input kW	COP
20	65/55	Operation Not Recommended				25200	3.169	2.33
	70/59					24900	3.330	2.19
	75/63					24600	3.491	2.06
	80/67					24300	3.652	1.95
	85/71					24000	3.814	1.84
30	65/55					29700	3.294	2.64
	70/59					29400	3.455	2.49
	75/63					29100	3.616	2.36
	80/67					28800	3.777	2.23
	85/71					28500	3.938	2.12
40	65/55	40300	28800	1.954	20.6	33800	3.409	2.91
	70/59	44600	30300	1.890	23.6	33500	3.570	2.75
	75/63	48800	31800	1.826	26.7	33200	3.731	2.61
	80/67	53100	33200	1.761	30.2	32900	3.892	2.48
	85/71	57400	34700	1.697	33.8	32600	4.053	2.36
50	65/55	38400	27400	2.344	16.4	37500	3.516	3.12
	70/59	42600	28900	2.280	18.7	37200	3.677	2.96
	75/63	46900	30300	2.216	21.2	36900	3.838	2.82
	80/67	51200	31800	2.151	23.8	36600	3.999	2.68
	85/71	55500	33300	2.087	26.6	36300	4.160	2.56
60	65/55	36200	26000	2.731	13.3	40800	3.613	3.31
	70/59	40500	27500	2.667	15.2	40500	3.774	3.14
	75/63	44800	28900	2.602	17.2	40200	3.935	2.99
	80/67	49100	30400	2.538	19.3	39900	4.096	2.85
	85/71	53400	31900	2.474	21.6	39600	4.257	2.73
70	65/55	33900	24600	3.114	10.9	43700	3.702	3.46
	70/59	38200	26100	3.050	12.5	43400	3.863	3.29
	75/63	42500	27600	2.985	14.2	43100	4.024	3.14
	80/67	46800	29000	2.921	16.0	42800	4.185	3.00
	85/71	51000	30500	2.857	17.9	42500	4.346	2.87
80	65/55	31400	23400	3.494	9.0	46200	3.781	3.58
	70/59	35600	24800	3.429	10.4	46000	3.942	3.42
	75/63	39900	26300	3.365	11.9	45700	4.103	3.26
	80/67	44200	27700	3.301	13.4	45400	4.265	3.12
	85/71	48500	29200	3.236	15.0	45100	4.426	2.99
90	65/55	28600	22100	3.870	7.4	48400	3.852	3.68
	70/59	32900	23600	3.805	8.6	48100	4.013	3.51
	75/63	37200	25000	3.741	9.9	47800	4.174	3.36
	80/67	41500	26500	3.677	11.3	47500	4.335	3.21
	85/71	45700	28000	3.612	12.7	47200	4.496	3.08

Size 036 (1250 SCFM) – 2nd Stage High Fan (Continued)

Entering Air Temperature Outdoor DB °F	Entering Air Temperature Indoor DB/WB °F	Cooling				Heating		
		Total Btuh	Sensible Btuh	Power Input kW	EER	Total Btuh	Power Input kW	COP
100	65/55	25600	20900	4.242	6.0	Operation Not Recommended		
	70/59	29900	22400	4.178	7.2			
	75/63	34200	23800	4.114	8.3			
	80/67	38500	25300	4.049	9.5			
	85/71	42800	26800	3.985	10.7			
110	65/55	22500	19800	4.611	4.9			
	70/59	26700	21200	4.547	5.9			
	75/63	31000	22700	4.483	6.9			
	80/67	35300	24200	4.418	8.0			
115	85/71	39600	25600	4.354	9.1			
	65/55	20800	19200	4.795	4.3			
	70/59	25100	20700	4.730	5.3			
	75/63	29400	22200	4.666	6.3			
	80/67	33600	23600	4.602	7.3			
	85/71	37900	25100	4.537	8.4			

Note: Capacity Data at Full Load

Legend: Btuh = British Thermal Units per Hour
 EER = Energy Efficiency Ratio
 kW = Kilowatt

DB = Dry Bulb
 WB = Wet Bulb

Size 036 (1000 SCFM) – 1st Stage Medium Fan

Entering Air Temperature Outdoor DB °F	Entering Air Temperature Indoor DB/WB °F	Cooling				Heating		
		Total Btuh	Sensible Btuh	Power Input kW	EER	Total Btuh	Power Input kW	COP
20	65/55	Operation Not Recommended				13300	2.743	1.42
	70/59					13000	2.865	1.33
	75/63					12600	2.987	1.24
	80/67					12300	3.108	1.16
	85/71					11900	3.230	1.08
30	65/55					18000	2.846	1.85
	70/59					17600	2.968	1.74
	75/63					17300	3.090	1.64
	80/67					16900	3.212	1.54
	85/71					16600	3.334	1.46
40	65/55	32200	19800	0.654	49.2	22100	2.927	2.21
	70/59	35100	19700	0.637	55.1	21700	3.049	2.09
	75/63	36900	21600	0.628	58.8	21400	3.171	1.98
	80/67	39200	22500	0.615	63.7	21000	3.292	1.87
	85/71	41500	23500	0.602	68.9	20700	3.414	1.78
50	65/55	30300	19200	1.160	26.1	25700	2.988	2.52
	70/59	33200	19100	1.143	29.0	25400	3.110	2.39
	75/63	34900	21100	1.134	30.8	25000	3.231	2.27
	80/67	37300	22000	1.121	33.3	24700	3.353	2.16
	85/71	39600	22900	1.108	35.7	24300	3.475	2.05
60	65/55	28200	18600	1.624	17.4	28800	3.032	2.78
	70/59	31100	18500	1.607	19.4	28500	3.154	2.65
	75/63	32900	20400	1.598	20.6	28200	3.276	2.52
	80/67	35200	21300	1.585	22.2	27800	3.398	2.40
	85/71	37600	22200	1.572	23.9	27500	3.519	2.29
70	65/55	26000	17800	2.046	12.7	31500	3.063	3.01
	70/59	28900	17700	2.029	14.2	31100	3.185	2.86
	75/63	30700	19600	2.020	15.2	30800	3.307	2.73
	80/67	33000	20600	2.007	16.4	30400	3.429	2.60
	85/71	35400	21500	1.994	17.8	30100	3.551	2.48
80	65/55	23700	17000	2.426	9.8	33600	3.085	3.19
	70/59	26600	16900	2.409	11.0	33300	3.207	3.04
	75/63	28400	18800	2.400	11.8	32900	3.329	2.90
	80/67	30700	19700	2.387	12.9	32600	3.451	2.77
	85/71	33000	20600	2.374	13.9	32200	3.572	2.64
90	65/55	21200	16100	2.764	7.7	35300	3.101	3.34
	70/59	24100	16000	2.747	8.8	34900	3.222	3.17
	75/63	25900	17900	2.738	9.5	34600	3.344	3.03
	80/67	28200	18800	2.725	10.3	34200	3.466	2.89
	85/71	30600	19700	2.712	11.3	33900	3.588	2.77

Size 036 (1000 SCFM) – 1st Stage Medium Fan (Continued)

Entering Air Temperature Outdoor DB °F	Entering Air Temperature Indoor DB/WB °F	Cooling				Heating		
		Total Btuh	Sensible Btuh	Power Input kW	EER	Total Btuh	Power Input kW	COP
100	65/55	18600	15000	3.059	6.1	Operation Not Recommended		
	70/59	21500	14900	3.042	7.1			
	75/63	23300	16900	3.033	7.7			
	80/67	25600	17800	3.020	8.5			
	85/71	27900	18700	3.007	9.3			
110	65/55	15900	13900	3.313	4.8			
	70/59	18800	13800	3.295	5.7			
	75/63	20500	15700	3.287	6.2			
	80/67	22900	16700	3.274	7.0			
115	85/71	25200	17600	3.260	7.7			
	65/55	14400	13300	3.424	4.2			
	70/59	17300	13200	3.406	5.1			
	75/63	19100	15200	3.397	5.6			
	80/67	21400	16100	3.384	6.3			
	85/71	23800	17000	3.371	7.1			

Note: Capacity Data at Full Load

Legend: Btuh = British Thermal Units per Hour
 EER = Energy Efficiency Ratio
 kW = Kilowatt

DB = Dry Bulb
 WB = Wet Bulb

Size 036 (800 SCFM) – 1st Stage Low Fan

Entering Air Temperature Outdoor DB °F	Entering Air Temperature Indoor DB/WB °F	Cooling				Heating		
		Total Btuh	Sensible Btuh	Power Input kW	EER	Total Btuh	Power Input kW	COP
20	65/55	Operation Not Recommended				12700	2.816	1.32
	70/59					12400	2.941	1.24
	75/63					12000	3.067	1.15
	80/67					11700	3.192	1.07
	85/71					11400	3.317	1.01
30	65/55					17100	2.923	1.71
	70/59					16800	3.048	1.61
	75/63					16400	3.173	1.51
	80/67					16100	3.298	1.43
	85/71					15800	3.423	1.35
40	65/55					30400	17800	0.640
	70/59	32700	18600	0.627	52.2	20700	3.130	1.94
	75/63	34900	19400	0.615	56.7	20400	3.256	1.84
	80/67	37100	20200	0.602	61.6	20000	3.381	1.73
	85/71	39300	21000	0.589	66.7	19700	3.506	1.65
50	65/55	28600	17200	1.136	25.2	24500	3.068	2.34
	70/59	30800	18100	1.123	27.4	24200	3.193	2.22
	75/63	33100	18900	1.110	29.8	23800	3.318	2.10
	80/67	35300	19700	1.098	32.1	23500	3.443	2.00
	85/71	37500	20500	1.085	34.6	23200	3.568	1.91
60	65/55	26700	16700	1.590	16.8	27500	3.113	2.59
	70/59	28900	17500	1.577	18.3	27100	3.238	2.45
	75/63	31100	18300	1.565	19.9	26800	3.363	2.33
	80/67	33300	19100	1.552	21.5	26500	3.489	2.23
	85/71	35500	19900	1.539	23.1	26100	3.614	2.12
70	65/55	24600	16000	2.003	12.3	30000	3.146	2.79
	70/59	26800	16800	1.990	13.5	29600	3.271	2.65
	75/63	29000	17600	1.978	14.7	29300	3.396	2.53
	80/67	31200	18400	1.965	15.9	29000	3.521	2.41
	85/71	33400	19300	1.952	17.1	28700	3.646	2.31
80	65/55	22400	15200	2.375	9.4	32000	3.168	2.96
	70/59	24600	16000	2.362	10.4	31700	3.293	2.82
	75/63	26800	16900	2.349	11.4	31400	3.418	2.69
	80/67	29000	17700	2.337	12.4	31000	3.543	2.56
	85/71	31200	18500	2.324	13.4	30700	3.668	2.45
90	65/55	20100	14400	2.706	7.4	33600	3.184	3.09
	70/59	22300	15200	2.693	8.3	33300	3.309	2.95
	75/63	24500	16000	2.680	9.1	32900	3.434	2.81
	80/67	26700	16800	2.667	10.0	32600	3.559	2.68
	85/71	28900	17700	2.655	10.9	32300	3.684	2.57

Size 036 (800 SCFM) – 1st Stage Low Fan (Continued)

Entering Air Temperature Outdoor DB °F	Entering Air Temperature Indoor DB/WB °F	Cooling				Heating		
		Total Btuh	Sensible Btuh	Power Input kW	EER	Total Btuh	Power Input kW	COP
100	65/55	17600	13500	2.995	5.9	Operation Not Recommended		
	70/59	19800	14300	2.982	6.6			
	75/63	22000	15100	2.969	7.4			
	80/67	24200	15900	2.957	8.2			
	85/71	26400	16800	2.944	9.0			
110	65/55	15000	12500	3.243	4.6			
	70/59	17200	13300	3.230	5.3			
	75/63	19400	14100	3.217	6.0			
	80/67	21600	14900	3.205	6.7			
	85/71	23800	15800	3.192	7.5			
115	65/55	13600	12000	3.351	4.1			
	70/59	15900	12800	3.339	4.8			
	75/63	18100	13600	3.326	5.4			
	80/67	20300	14400	3.313	6.1			
	85/71	22500	15200	3.300	6.8			

Note: Capacity Data at Full Load

Legend: Btuh = British Thermal Units per Hour
 EER = Energy Efficiency Ratio
 kW = Kilowatt

DB = Dry Bulb
 WB = Wet Bulb

Size 044 (1500 SCFM) – 2nd Stage High Fan

Entering Air Temperature Outdoor DB °F	Entering Air Temperature Indoor DB/WB °F	Cooling				Heating		
		Total Btuh	Sensible Btuh	Power Input kW	EER	Total Btuh	Power Input kW	COP
20	65/55	Operation Not Recommended				27900	3.831	2.13
	70/59					27100	4.030	1.97
	75/63					26200	4.230	1.81
	80/67					25400	4.429	1.68
	85/71					24600	4.628	1.56
30	65/55					34000	3.926	2.54
	70/59					33200	4.125	2.36
	75/63					32400	4.325	2.19
	80/67					31600	4.524	2.05
	85/71					30800	4.723	1.91
40	65/55	44200	30700	2.994	14.8	39700	4.021	2.89
	70/59	47900	31900	3.027	15.8	38800	4.220	2.69
	75/63	51500	33000	3.060	16.8	38000	4.420	2.52
	80/67	55200	34100	3.092	17.9	37200	4.619	2.36
	85/71	58800	35300	3.125	18.8	36400	4.818	2.21
50	65/55	43100	30400	3.101	13.9	44700	4.116	3.18
	70/59	46700	31600	3.134	14.9	43900	4.315	2.98
	75/63	50400	32700	3.167	15.9	43100	4.515	2.80
	80/67	54000	33900	3.199	16.9	42300	4.714	2.63
	85/71	57600	35000	3.232	17.8	41500	4.913	2.47
60	65/55	41500	29900	3.261	12.7	49300	4.211	3.43
	70/59	45100	31100	3.293	13.7	48500	4.410	3.22
	75/63	48800	32200	3.326	14.7	47600	4.610	3.03
	80/67	52400	33400	3.359	15.6	46800	4.809	2.85
	85/71	56100	34500	3.392	16.5	46000	5.008	2.69
70	65/55	39500	29200	3.473	11.4	53300	4.306	3.63
	70/59	43100	30300	3.505	12.3	52500	4.505	3.41
	75/63	46800	31500	3.538	13.2	51700	4.705	3.22
	80/67	50400	32600	3.571	14.1	50800	4.904	3.04
	85/71	54000	33800	3.604	15.0	50000	5.103	2.87
80	65/55	37000	28200	3.737	9.9	56800	4.401	3.78
	70/59	40700	29300	3.770	10.8	56000	4.600	3.57
	75/63	44300	30500	3.802	11.7	55100	4.800	3.36
	80/67	47900	31600	3.835	12.5	54300	4.999	3.18
	85/71	51600	32800	3.868	13.3	53500	5.198	3.02
90	65/55	34100	26900	4.053	8.4	59700	4.496	3.89
	70/59	37800	28100	4.086	9.3	58900	4.695	3.68
	75/63	41400	29200	4.119	10.1	58100	4.894	3.48
	80/67	45100	30400	4.152	10.9	57300	5.094	3.30
	85/71	48700	31500	4.184	11.6	56500	5.293	3.13

Size 044 (1500 SCFM) – 2nd Stage High Fan (Continued)

Entering Air Temperature Outdoor DB °F	Entering Air Temperature Indoor DB/WB °F	Cooling				Heating		
		Total Btuh	Sensible Btuh	Power Input kW	EER	Total Btuh	Power Input kW	COP
100	65/55	30800	25400	4.422	7.0	Operation Not Recommended		
	70/59	34500	26600	4.455	7.7			
	75/63	38100	27700	4.488	8.5			
	80/67	41800	28900	4.521	9.2			
	85/71	45400	30000	4.553	10.0			
110	65/55	27100	23700	4.844	5.6			
	70/59	30700	24800	4.876	6.3			
	75/63	34400	26000	4.909	7.0			
	80/67	38000	27100	4.942	7.7			
	85/71	41700	28300	4.975	8.4			
115	65/55	25100	22700	5.074	4.9			
	70/59	28700	23900	5.107	5.6			
	75/63	32300	25000	5.139	6.3			
	80/67	36000	26100	5.172	7.0			
	85/71	39600	27300	5.205	7.6			

Note: Capacity Data at Full Load

Legend: Btuh = British Thermal Units per Hour
 EER = Energy Efficiency Ratio
 kW = Kilowatt

DB = Dry Bulb
 WB = Wet Bulb

Size 044 (1050 SCFM) – 1st Stage Medium Fan

Entering Air Temperature Outdoor DB °F	Entering Air Temperature Indoor DB/WB °F	Cooling				Heating		
		Total Btuh	Sensible Btuh	Power Input kW	EER	Total Btuh	Power Input kW	COP
20	65/55	Operation Not Recommended				20500	3.089	1.94
	70/59					20000	3.260	1.80
	75/63					19500	3.432	1.66
	80/67					19000	3.603	1.55
	85/71					18500	3.774	1.44
30	65/55					25100	3.172	2.32
	70/59					24600	3.343	2.16
	75/63					24100	3.514	2.01
	80/67					23600	3.686	1.88
	85/71					23100	3.857	1.75
40	65/55	33100	21300	2.015	16.4	29300	3.247	2.64
	70/59	35500	22200	1.990	17.8	28700	3.418	2.46
	75/63	37800	23100	1.966	19.2	28200	3.589	2.30
	80/67	40200	24000	1.941	20.7	27700	3.761	2.16
	85/71	42500	24800	1.917	22.2	27200	3.932	2.03
50	65/55	31900	21200	2.139	14.9	33000	3.315	2.92
	70/59	34300	22100	2.115	16.2	32500	3.486	2.73
	75/63	36600	23000	2.090	17.5	32000	3.657	2.56
	80/67	39000	23900	2.066	18.9	31500	3.828	2.41
	85/71	41300	24800	2.041	20.2	31000	4.000	2.27
60	65/55	30500	20900	2.299	13.3	36300	3.375	3.15
	70/59	32800	21800	2.275	14.4	35800	3.546	2.96
	75/63	35200	22700	2.250	15.6	35300	3.717	2.78
	80/67	37500	23600	2.226	16.8	34800	3.888	2.62
	85/71	39900	24500	2.201	18.1	34300	4.060	2.48
70	65/55	28800	20500	2.495	11.5	39100	3.427	3.34
	70/59	31100	21300	2.471	12.6	38600	3.599	3.14
	75/63	33400	22200	2.446	13.7	38100	3.770	2.96
	80/67	35800	23100	2.422	14.8	37600	3.941	2.80
	85/71	38100	24000	2.397	15.9	37100	4.112	2.64
80	65/55	26700	19800	2.727	9.8	41600	3.472	3.51
	70/59	29100	20700	2.702	10.8	41100	3.644	3.30
	75/63	31400	21500	2.678	11.7	40600	3.815	3.12
	80/67	33800	22400	2.653	12.7	40100	3.986	2.95
	85/71	36100	23300	2.629	13.7	39500	4.157	2.78
90	65/55	24400	18900	2.994	8.1	43600	3.510	3.64
	70/59	26800	19800	2.969	9.0	43000	3.681	3.42
	75/63	29100	20600	2.945	9.9	42500	3.853	3.23
	80/67	31500	21500	2.920	10.8	42000	4.024	3.06
	85/71	33800	22400	2.896	11.7	41500	4.195	2.90

Size 044 (1050 SCFM) – 1st Stage Medium Fan (Continued)

Entering Air Temperature Outdoor DB °F	Entering Air Temperature Indoor DB/WB °F	Cooling				Heating		
		Total Btuh	Sensible Btuh	Power Input kW	EER	Total Btuh	Power Input kW	COP
100	65/55	21800	17800	3.296	6.6	Operation Not Recommended		
	70/59	24200	18700	3.272	7.4			
	75/63	26500	19600	3.247	8.2			
	80/67	28900	20400	3.223	9.0			
	85/71	31200	21300	3.198	9.8			
110	65/55	18900	16500	3.634	5.2			
	70/59	21300	17400	3.610	5.9			
	75/63	23600	18300	3.585	6.6			
	80/67	26000	19100	3.561	7.3			
	85/71	28300	20000	3.537	8.0			
115	65/55	17400	15800	3.817	4.6			
	70/59	19700	16600	3.792	5.2			
	75/63	22100	17500	3.768	5.9			
	80/67	24400	18400	3.743	6.5			
	85/71	26800	19300	3.719	7.2			

Note: Capacity Data at Full Load

Legend: Btuh = British Thermal Units per Hour
 EER = Energy Efficiency Ratio
 kW = Kilowatt

DB = Dry Bulb
 WB = Wet Bulb

Size 044 (850 SCFM) – 1st Stage Low Fan

Entering Air Temperature Outdoor DB °F	Entering Air Temperature Indoor DB/WB °F	Cooling				Heating		
		Total Btuh	Sensible Btuh	Power Input kW	EER	Total Btuh	Power Input kW	COP
20	65/55	Operation Not Recommended				19900	3.215	1.81
	70/59					19500	3.393	1.68
	75/63					19000	3.571	1.56
	80/67					18500	3.749	1.45
	85/71					18000	3.927	1.34
30	65/55					24400	3.301	2.17
	70/59					23900	3.479	2.01
	75/63					23400	3.657	1.87
	80/67					23000	3.835	1.76
	85/71					22500	4.013	1.64
40	65/55	31400	20100	2.046	15.3	28500	3.379	2.47
	70/59	33600	21000	2.021	16.6	28000	3.557	2.31
	75/63	35800	21800	1.996	17.9	27500	3.735	2.16
	80/67	38100	22600	1.972	19.3	27000	3.913	2.02
	85/71	40300	23500	1.947	20.7	26500	4.092	1.90
50	65/55	30300	20000	2.173	13.9	32100	3.449	2.73
	70/59	32500	20900	2.148	15.1	31600	3.627	2.55
	75/63	34700	21700	2.123	16.3	31100	3.806	2.39
	80/67	36900	22500	2.098	17.6	30600	3.984	2.25
	85/71	39200	23400	2.073	18.9	30200	4.162	2.13
60	65/55	28900	19800	2.335	12.4	35300	3.512	2.94
	70/59	31100	20600	2.311	13.5	34800	3.690	2.76
	75/63	33300	21400	2.286	14.6	34400	3.868	2.61
	80/67	35600	22300	2.261	15.7	33900	4.046	2.45
	85/71	37800	23100	2.236	16.9	33400	4.225	2.32
70	65/55	27200	19300	2.534	10.7	38100	3.566	3.13
	70/59	29500	20100	2.509	11.8	37600	3.745	2.94
	75/63	31700	21000	2.485	12.8	37100	3.923	2.77
	80/67	33900	21800	2.460	13.8	36600	4.101	2.61
	85/71	36100	22700	2.435	14.8	36200	4.279	2.48
80	65/55	25300	18700	2.769	9.1	40500	3.613	3.28
	70/59	27600	19500	2.745	10.1	40000	3.792	3.09
	75/63	29800	20300	2.720	11.0	39500	3.970	2.92
	80/67	32000	21200	2.695	11.9	39000	4.148	2.75
	85/71	34200	22000	2.670	12.8	38500	4.326	2.61
90	65/55	23100	17800	3.041	7.6	42400	3.653	3.40
	70/59	25400	18700	3.016	8.4	41900	3.831	3.20
	75/63	27600	19500	2.991	9.2	41400	4.009	3.03
	80/67	29800	20300	2.966	10.0	40900	4.187	2.86
	85/71	32000	21200	2.941	10.9	40400	4.365	2.71

Size 044 (850 SCFM) – 1st Stage Low Fan (Continued)

Entering Air Temperature Outdoor DB °F	Entering Air Temperature Indoor DB/WB °F	Cooling				Heating		
		Total Btuh	Sensible Btuh	Power Input kW	EER	Total Btuh	Power Input kW	COP
100	65/55	20700	16800	3.348	6.2	Operation Not Recommended		
	70/59	22900	17600	3.323	6.9			
	75/63	25100	18500	3.298	7.6			
	80/67	27300	19300	3.273	8.3			
	85/71	29600	20100	3.249	9.1			
110	65/55	17900	15600	3.691	4.8			
	70/59	20100	16400	3.667	5.5			
	75/63	22400	17200	3.642	6.2			
	80/67	24600	18100	3.617	6.8			
	85/71	26800	18900	3.592	7.5			
115	65/55	16500	14900	3.877	4.3			
	70/59	18700	15700	3.852	4.9			
	75/63	20900	16600	3.827	5.5			
	80/67	23100	17400	3.802	6.1			
	85/71	25400	18200	3.777	6.7			

Note: Capacity Data at Full Load

Legend: Btuh = British Thermal Units per Hour
 EER = Energy Efficiency Ratio
 kW = Kilowatt

DB = Dry Bulb
 WB = Wet Bulb

Size 054 (1500 SCFM) – 2nd Stage High Fan

Entering Air Temperature Outdoor DB °F	Entering Air Temperature Indoor DB/WB °F	Cooling				Heating		
		Total Btuh	Sensible Btuh	Power Input kW	EER	Total Btuh	Power Input kW	COP
20	65/55	Operation Not Recommended				37400	4.690	2.34
	70/59					36600	4.939	2.17
	75/63					35800	5.188	2.02
	80/67					35000	5.437	1.89
	85/71					34200	5.685	1.76
30	65/55					43600	4.819	2.65
	70/59					42800	5.067	2.47
	75/63					42000	5.316	2.31
	80/67					41200	5.565	2.17
	85/71					40500	5.814	2.04
40	65/55	52700	36500	3.469	15.2	49400	4.947	2.93
	70/59	56700	37800	3.517	16.1	48600	5.196	2.74
	75/63	60600	39100	3.564	17.0	47800	5.444	2.57
	80/67	64600	40300	3.612	17.9	47000	5.693	2.42
	85/71	68500	41600	3.659	18.7	46200	5.942	2.28
50	65/55	51600	35600	3.589	14.4	54600	5.075	3.15
	70/59	55600	36900	3.636	15.3	53800	5.324	2.96
	75/63	59500	38200	3.684	16.2	53000	5.573	2.79
	80/67	63500	39400	3.731	17.0	52200	5.821	2.63
	85/71	67400	40700	3.779	17.8	51500	6.070	2.49
60	65/55	50000	34600	3.774	13.2	59400	5.203	3.35
	70/59	54000	35900	3.822	14.1	58600	5.452	3.15
	75/63	57900	37100	3.869	15.0	57800	5.701	2.97
	80/67	61900	38400	3.917	15.8	57000	5.950	2.81
	85/71	65800	39700	3.964	16.6	56200	6.198	2.66
70	65/55	47900	33400	4.026	11.9	63600	5.331	3.50
	70/59	51800	34700	4.074	12.7	62800	5.580	3.30
	75/63	55800	36000	4.121	13.5	62100	5.829	3.12
	80/67	59700	37200	4.169	14.3	61300	6.078	2.96
	85/71	63700	38500	4.216	15.1	60500	6.326	2.80
80	65/55	45200	32100	4.344	10.4	67400	5.460	3.62
	70/59	49100	33400	4.392	11.2	66600	5.708	3.42
	75/63	53100	34700	4.439	12.0	65800	5.957	3.24
	80/67	57000	35900	4.487	12.7	65000	6.206	3.07
	85/71	61000	37200	4.534	13.5	64300	6.455	2.92
90	65/55	42000	30700	4.729	8.9	70700	5.588	3.71
	70/59	45900	32000	4.776	9.6	69900	5.837	3.51
	75/63	49900	33300	4.824	10.3	69100	6.085	3.33
	80/67	53800	34500	4.871	11.0	68300	6.334	3.16
	85/71	57800	35800	4.919	11.8	67500	6.583	3.00

Size 054 (1500 SCFM) – 2nd Stage High Fan (Continued)

Entering Air Temperature Outdoor DB °F	Entering Air Temperature Indoor DB/WB °F	Cooling				Heating		
		Total Btuh	Sensible Btuh	Power Input kW	EER	Total Btuh	Power Input kW	COP
100	65/55	38300	29200	5.179	7.4	Operation Not Recommended		
	70/59	42200	30400	5.227	8.1			
	75/63	46200	31700	5.274	8.8			
	80/67	50100	33000	5.322	9.4			
	85/71	54100	34200	5.369	10.1			
110	65/55	34000	27500	5.696	6.0			
	70/59	38000	28800	5.744	6.6			
	75/63	41900	30000	5.791	7.2			
	80/67	45900	31300	5.839	7.9			
	85/71	49800	32600	5.886	8.5			
115	65/55	31700	26600	5.980	5.3			
	70/59	35600	27900	6.027	5.9			
	75/63	39600	29100	6.074	6.5			
	80/67	43500	30400	6.122	7.1			
	85/71	47500	31700	6.169	7.7			

Note: Capacity Data at Full Load

Legend: Btuh = British Thermal Units per Hour
 EER = Energy Efficiency Ratio
 kW = Kilowatt

DB = Dry Bulb
 WB = Wet Bulb

Size 054 (1050 SCFM) – 1st Stage Medium Fan

Entering Air Temperature Outdoor DB °F	Entering Air Temperature Indoor DB/WB °F	Cooling				Heating		
		Total Btuh	Sensible Btuh	Power Input kW	EER	Total Btuh	Power Input kW	COP
20	65/55	Operation Not Recommended				20800	2.994	2.04
	70/59					20200	3.164	1.87
	75/63					19600	3.333	1.72
	80/67					19000	3.503	1.59
	85/71					18400	3.672	1.47
30	65/55					25200	3.225	2.29
	70/59					24600	3.394	2.12
	75/63					24000	3.564	1.97
	80/67					23400	3.733	1.84
	85/71					22800	3.903	1.71
40	65/55	34100	22100	2.042	16.7	29300	3.423	2.51
	70/59	36300	22900	2.024	17.9	28700	3.592	2.34
	75/63	38500	23700	2.006	19.2	28000	3.762	2.18
	80/67	40700	24500	1.988	20.5	27400	3.931	2.04
	85/71	42900	25300	1.970	21.8	26800	4.101	1.91
50	65/55	32700	21800	2.209	14.8	32900	3.589	2.69
	70/59	35000	22600	2.191	16.0	32300	3.759	2.52
	75/63	37200	23300	2.173	17.1	31700	3.928	2.36
	80/67	39400	24100	2.156	18.3	31000	4.098	2.22
	85/71	41600	24900	2.138	19.5	30400	4.267	2.09
60	65/55	31100	21200	2.407	12.9	36100	3.723	2.84
	70/59	33300	22000	2.390	13.9	35500	3.893	2.67
	75/63	35500	22800	2.372	15.0	34900	4.062	2.52
	80/67	37800	23600	2.354	16.1	34200	4.232	2.37
	85/71	40000	24400	2.336	17.1	33600	4.401	2.24
70	65/55	29300	20500	2.637	11.1	38900	3.825	2.98
	70/59	31500	21300	2.619	12.0	38300	3.994	2.81
	75/63	33700	22100	2.601	13.0	37600	4.164	2.65
	80/67	35900	22900	2.583	13.9	37000	4.333	2.50
	85/71	38100	23700	2.566	14.8	36400	4.503	2.37
80	65/55	27200	19700	2.897	9.4	41200	3.895	3.10
	70/59	29400	20500	2.880	10.2	40600	4.064	2.93
	75/63	31600	21300	2.862	11.0	40000	4.234	2.77
	80/67	33800	22100	2.844	11.9	39400	4.403	2.62
	85/71	36000	22900	2.826	12.7	38800	4.573	2.49
90	65/55	24900	18700	3.189	7.8	43200	3.932	3.22
	70/59	27100	19500	3.171	8.5	42600	4.102	3.04
	75/63	29300	20300	3.153	9.3	42000	4.271	2.88
	80/67	31500	21100	3.136	10.0	41400	4.441	2.73
	85/71	33700	21900	3.118	10.8	40800	4.610	2.59

Size 054 (1050 SCFM) – 1st Stage Medium Fan (Continued)

Entering Air Temperature Outdoor DB °F	Entering Air Temperature Indoor DB/WB °F	Cooling				Heating		
		Total Btuh	Sensible Btuh	Power Input kW	EER	Total Btuh	Power Input kW	COP
100	65/55	22300	17600	3.512	6.3	Operation Not Recommended		
	70/59	24500	18400	3.494	7.0			
	75/63	26700	19200	3.476	7.7			
	80/67	28900	20000	3.458	8.4			
	85/71	31100	20800	3.440	9.0			
110	65/55	19500	16400	3.865	5.0			
	70/59	21700	17200	3.847	5.6			
	75/63	23900	17900	3.830	6.2			
	80/67	26100	18700	3.812	6.8			
	85/71	28300	19500	3.794	7.5			
115	65/55	18000	15700	4.054	4.4			
	70/59	20200	16500	4.036	5.0			
	75/63	22400	17300	4.018	5.6			
	80/67	24600	18000	4.000	6.2			
	85/71	26900	18800	3.983	6.8			

Note: Capacity Data at Full Load

Legend: *Btuh* = British Thermal Units per Hour

EER = Energy Efficiency Ratio

kW = Kilowatt

DB = Dry Bulb

WB = Wet Bulb

Size 054 (850 SCFM) – 1st Stage Low Fan

Entering Air Temperature Outdoor DB °F	Entering Air Temperature Indoor DB/WB °F	Cooling				Heating		
		Total Btuh	Sensible Btuh	Power Input kW	EER	Total Btuh	Power Input kW	COP
20	65/55	Operation Not Recommended				19500	3.286	1.74
	70/59					18900	3.472	1.59
	75/63					18300	3.658	1.47
	80/67					17800	3.844	1.36
	85/71					17200	4.030	1.25
30	65/55					23600	3.539	1.95
	70/59					23000	3.725	1.81
	75/63					22500	3.911	1.69
	80/67					21900	4.097	1.57
	85/71					21300	4.283	1.46
40	65/55	30900	18700	2.077	14.9	27400	3.756	2.14
	70/59	32900	19400	2.059	16.0	26800	3.942	1.99
	75/63	34900	20100	2.041	17.1	26200	4.128	1.86
	80/67	36900	20800	2.023	18.2	25700	4.314	1.75
	85/71	38900	21400	2.005	19.4	25100	4.500	1.63
50	65/55	29700	18400	2.248	13.2	30800	3.938	2.29
	70/59	31700	19100	2.230	14.2	30200	4.124	2.15
	75/63	33700	19800	2.211	15.2	29600	4.310	2.01
	80/67	35700	20400	2.193	16.3	29000	4.497	1.89
	85/71	37700	21100	2.175	17.3	28500	4.683	1.78
60	65/55	28200	18000	2.450	11.5	33800	4.085	2.42
	70/59	30200	18600	2.431	12.4	33200	4.272	2.28
	75/63	32200	19300	2.413	13.3	32600	4.458	2.14
	80/67	34200	20000	2.395	14.3	32000	4.644	2.02
	85/71	36200	20700	2.377	15.2	31500	4.830	1.91
70	65/55	26500	17400	2.683	9.9	36400	4.197	2.54
	70/59	28500	18100	2.665	10.7	35800	4.383	2.39
	75/63	30500	18700	2.647	11.5	35200	4.569	2.26
	80/67	32500	19400	2.629	12.4	34700	4.755	2.14
	85/71	34500	20100	2.611	13.2	34100	4.941	2.02
80	65/55	24600	16700	2.948	8.3	38600	4.274	2.65
	70/59	26600	17400	2.930	9.1	38000	4.460	2.50
	75/63	28600	18000	2.912	9.8	37400	4.646	2.36
	80/67	30600	18700	2.894	10.6	36900	4.832	2.24
	85/71	32600	19400	2.876	11.3	36300	5.018	2.12
90	65/55	22500	15900	3.245	6.9	40400	4.315	2.74
	70/59	24500	16500	3.227	7.6	39900	4.501	2.60
	75/63	26500	17200	3.209	8.3	39300	4.687	2.46
	80/67	28500	17900	3.191	8.9	38700	4.873	2.33
	85/71	30500	18600	3.173	9.6	38100	5.059	2.21

Size 054 (850 SCFM) – 1st Stage Low Fan (Continued)

Entering Air Temperature Outdoor DB °F	Entering Air Temperature Indoor DB/WB °F	Cooling				Heating		
		Total Btuh	Sensible Btuh	Power Input kW	EER	Total Btuh	Power Input kW	COP
100	65/55	20200	14900	3.573	5.7	Operation Not Recommended		
	70/59	22200	15600	3.555	6.2			
	75/63	24200	16300	3.537	6.8			
	80/67	26200	16900	3.519	7.4			
	85/71	28200	17600	3.501	8.1			
110	65/55	17700	13800	3.933	4.5			
	70/59	19700	14500	3.915	5.0			
	75/63	21700	15200	3.897	5.6			
	80/67	23700	15900	3.879	6.1			
	85/71	25700	16500	3.861	6.7			
115	65/55	16300	13300	4.125	4.0			
	70/59	18300	13900	4.107	4.5			
	75/63	20300	14600	4.089	5.0			
	80/67	22300	15300	4.071	5.5			
	85/71	24300	16000	4.053	6.0			

Note: Capacity Data at Full Load

Legend: Btuh = British Thermal Units per Hour
 EER = Energy Efficiency Ratio
 kW = Kilowatt

DB = Dry Bulb
 WB = Wet Bulb

AEQ – Size 024

Volt/Hz/Phase	Voltage Range		Room Fan FLA	Outdoor Fan FLA	Compressor		Heating Option			Power Supply		
	Min.	Max.			RLA	LRA	Heat Type	Heater kW	Rated Heater Amps	MCA	Maximum Fuse	
208/60/1	197	228	3.2	2.8	11.7	58.3	Elec. Heat ¹	Low (3 elem.)	8.0	38.5	70.25	80
			3.2	2.8	11.7	58.3		High (6 elem.)	16.0	76.9	118.25	125
230/60/1	207	253	3.2	2.8	11.7	58.3	Elec. Heat ¹	Low (3 elem.)	7.3	33.3	63.75	70
			3.2	2.8	11.7	58.3		High (6 elem.)	14.7	66.7	105.50	110
208/60/3	197	228	3.2	2.8	6.5	55.4	Elec. Heat ¹	Low (3 elem.)	8.0	22.2	43.38	45
			3.2	2.8	6.5	55.4		High (6 elem.)	16.0	44.4	71.13	80
230/60/3	207	253	3.2	2.8	6.5	55.4	Elec. Heat ¹	Low (3 elem.)	7.3	19.2	39.63	40
			3.2	2.8	6.5	55.4		High (6 elem.)	14.7	38.5	63.75	70
460/60/3	414	506	3.2	1.5	3.5	28.0	Elec. Heat ¹	Low (3 elem.)	7.3	9.6	22.25	25
			3.2	1.5	3.5	28.0		High (6 elem.)	14.7	19.2	34.25	35

¹ Electric Heat Options are with Compressor and Outdoor Fan.

AEQ – Size 036

Volt/Hz/Phase	Voltage Range		Room Fan FLA	Outdoor Fan FLA	Compressor		Heating Option			Power Supply		
	Min.	Max.			RLA	LRA	Heat Type	Heater kW	Rated Heater Amps	MCA	Maximum Fuse	
208/60/1	197	228	3.2	6.3	17.9	96.0	Elec. Heat ¹	Low (3 elem.)	10.0	48.1	94.38	100
			3.2	6.3	17.9	96.0		High (6 elem.)	20.0	96.2	154.50	175
230/60/1	207	253	3.2	5.7	17.9	96.0	Elec. Heat ¹	Low (3 elem.)	9.2	41.7	85.63	90
			3.2	5.7	17.9	96.0		High (6 elem.)	18.4	83.3	137.63	150
208/60/3	197	228	3.2	6.3	14.2	88.0	Elec. Heat ¹	Low (3 elem.)	10.0	27.8	64.38	70
			3.2	6.3	14.2	88.0		High (6 elem.)	20.0	55.5	99.00	100
230/60/3	207	253	3.2	5.7	14.2	88.0	Elec. Heat ¹	Low (3 elem.)	9.2	24.1	59.00	60
			3.2	5.7	14.2	88.0		High (6 elem.)	18.4	48.1	89.00	90
460/60/3	414	506	3.2	3.1	6.2	44.0	Elec. Heat ¹	Low (3 elem.)	9.2	12.0	30.63	35
			3.2	3.1	6.2	44.0		High (6 elem.)	18.4	24.1	45.75	50

¹ Electric Heat Options are with Compressor and Outdoor Fan.

AEQ – Size 044

Volt/Hz/Phase	Voltage Range		Room Fan FLA	Outdoor Fan FLA	Compressor		Heating Option			Power Supply		
	Min.	Max.			RLA	LRA	Heat Type	Heater kW	Rated Heater Amps	MCA	Maximum Fuse	
208/60/1	197	228	3.2	6.3	21.2	104.0	Elec. Heat ¹	Low (3 elem.)	12.0	57.7	110.50	125
			3.2	6.3	21.2	104.0		High (6 elem.)	24.0	115.4	182.63	200
230/60/1	207	253	3.2	5.7	21.2	104.0	Elec. Heat ¹	Low (3 elem.)	11.0	50.0	100.13	110
			3.2	5.7	21.2	104.0		High (6 elem.)	22.0	100.0	162.63	175
208/60/3	197	228	3.2	6.3	14.0	83.1	Elec. Heat ¹	Low (3 elem.)	12.0	33.3	71.00	80
			3.2	6.3	14.0	83.1		High (6 elem.)	24.0	66.6	112.63	125
230/60/3	207	253	3.2	5.7	14.0	83.1	Elec. Heat ¹	Low (3 elem.)	11.0	28.9	64.75	70
			3.2	5.7	14.0	83.1		High (6 elem.)	22.0	57.7	100.75	110
460/60/3	414	506	3.2	3.1	6.4	41.0	Elec. Heat ¹	Low (3 elem.)	11.0	14.4	33.88	35
			3.2	3.1	6.4	41.0		High (6 elem.)	22.0	28.9	52.00	60

¹ Electric Heat Options are with Compressor and Outdoor Fan.

FLA = Full Load Amps

RLA = Rated Load Amps

LRA = Locked Rotor Amps

MCA = Minimum Circuit Ampacity

AEQ – Size 054

Volt/Hz/Phase	Voltage Range		Room Fan FLA	Outdoor Fan FLA	Compressor		Heating Option				Power Supply	
	Min.	Max.			RLA	LRA	Heat Type		Heater kW	Rated Heater Amps	MCA	Maximum Fuse
208/60/1	197	228	3.0	6.3	27.1	152.9	Elec. Heat ¹	Low (3 elem.)	12.0	57.7	117.60	125
			3.0	6.3	27.1	152.9		High (6 elem.)	24.0	115.4	189.80	200
230/60/1	207	253	2.8	5.7	27.1	152.9	Elec. Heat ¹	Low (3 elem.)	11.0	50.0	107.00	110
			2.8	5.7	27.1	152.9		High (6 elem.)	22.0	100.0	169.50	175
208/60/3	197	228	3.0	6.3	16.5	110.0	Elec. Heat ¹	Low (3 elem.)	12.0	33.6	73.90	80
			3.0	6.3	16.5	110.0		High (6 elem.)	24.0	66.6	115.50	125
230/60/3	207	253	2.8	5.7	16.5	110.0	Elec. Heat ¹	Low (3 elem.)	11.0	28.9	67.40	70
			2.8	5.7	16.5	110.0		High (6 elem.)	22.0	57.7	103.40	110
460/60/3	414	506	2.8	3.1	7.2	52.0	Elec. Heat ¹	Low (3 elem.)	11.0	14.4	34.40	35
			2.8	3.1	7.2	52.0		High (6 elem.)	22.0	28.9	52.50	60

¹ Electric Heat Options are with Compressor and Outdoor Fan.
FLA = Full Load Amps

RLA = Rated Load Amps

LRA = Locked Rotor Amps

MCA = Minimum Circuit Ampacity

Table 11: Wiring Diagram Legend for Figure 32 on page 59 and Figure 33

Symbol	Description	Symbol	Description	Symbol	Description
A1	Actuator- Outdoor Air	ICT	Sensor - Indoor DX Coil Temperature	R28	Relay - Outdoor Motor Air
A2	Actuator- Face & Bypass	IH	Sensor - Indoor Humidity	RV	Reversing Valve
C1	Compressor Contactor	MCB	Main Control Board	RAT	Sensor - Room Air Temperature
CAP1	Capacitor Run	NTWK	Network Connection	T6	Thermostat - Freeze Stat
CEH1-3	Electric Heat Contactor	OAT	Sensor - Outdoor Air Temperature	TB1	Terminal Block - 24VAC+
CO2	Sensor - Indoor Air CO2	OCT	Sensor - Outdoor DX Coil Temperature	TB2	Terminal Block - 24VAC Gnd
DAT	Sensor - Discharge Air Temperature	OH	Sensor - Outdoor Humidity	TB3	(A, B) Terminal Block - Main Power
DCS	Switch - Unit Power	OH1	Thermostat - Overheat	TBE	Terminal Block - Electric Heat
DF	Dead Front Switch	OH2	Thermostat - Overheat	TR1	Transformer - Motor Speed
EH1-6	Heater - Electric	OHM	E.H. Man Reset - Overheat Stat	TR3	Transformer - 208 / 230V-24V, 75VA
EH10	Heater - Outdoor Drain Pan	PL1	LED Occupancy / Fault Status	TR4	Transformer - 460V-230V
F1A/F1B	Fuse - Compressor	R1-R3	Relay Electric Heat (Backup)	TR5	Transformer - 208 / 230V-24V
F2A/F3C	Fuse - Electric Heat	R10-R12	Relay - Electric Heat	V1	Valve - Heat EOC (Accessory)
FA/FB	Fuse- Control, Load	R4H	Relay - Fan High Speed	V2	Valve - Cool EOC (Accessory)
FC/FD	Fuse- Control, Transformer	R4M	Relay- Fan Medium Speed	VH	Valve - Heat (Accessory)
FMI	Motor - Room Fan	R4L	Relay- Fan Low Speed	VC	Valve - Cool (Accessory)
FMO	Motor Outdoor Air	R32	Relay - Drain Pan Heater		
HP	High Pressure Switch				

- Notes:**
- All electrical installation must be in accordance with national and local electrical codes and job wiring schematic.
 - External wiring options - see IM for the different configured options, wiring to be minimum 18 gauge, 90°C.
 - EC motors are factory programmed for specified air flow. Contact Daikin Applied for replacement.
 - Cap extra wire. Switch wire 42A to red wire for 208V operation.
 - Switch wire 509 to terminal 2 for 208V operation.
 - Devices in legend may or may not be on unit.

Typical MicroTech Wiring Diagram – 208V / 60Hz / 1Ph

Figure 32: MicroTech Controls Wiring Diagram – 208V / 60Hz / 1Ph

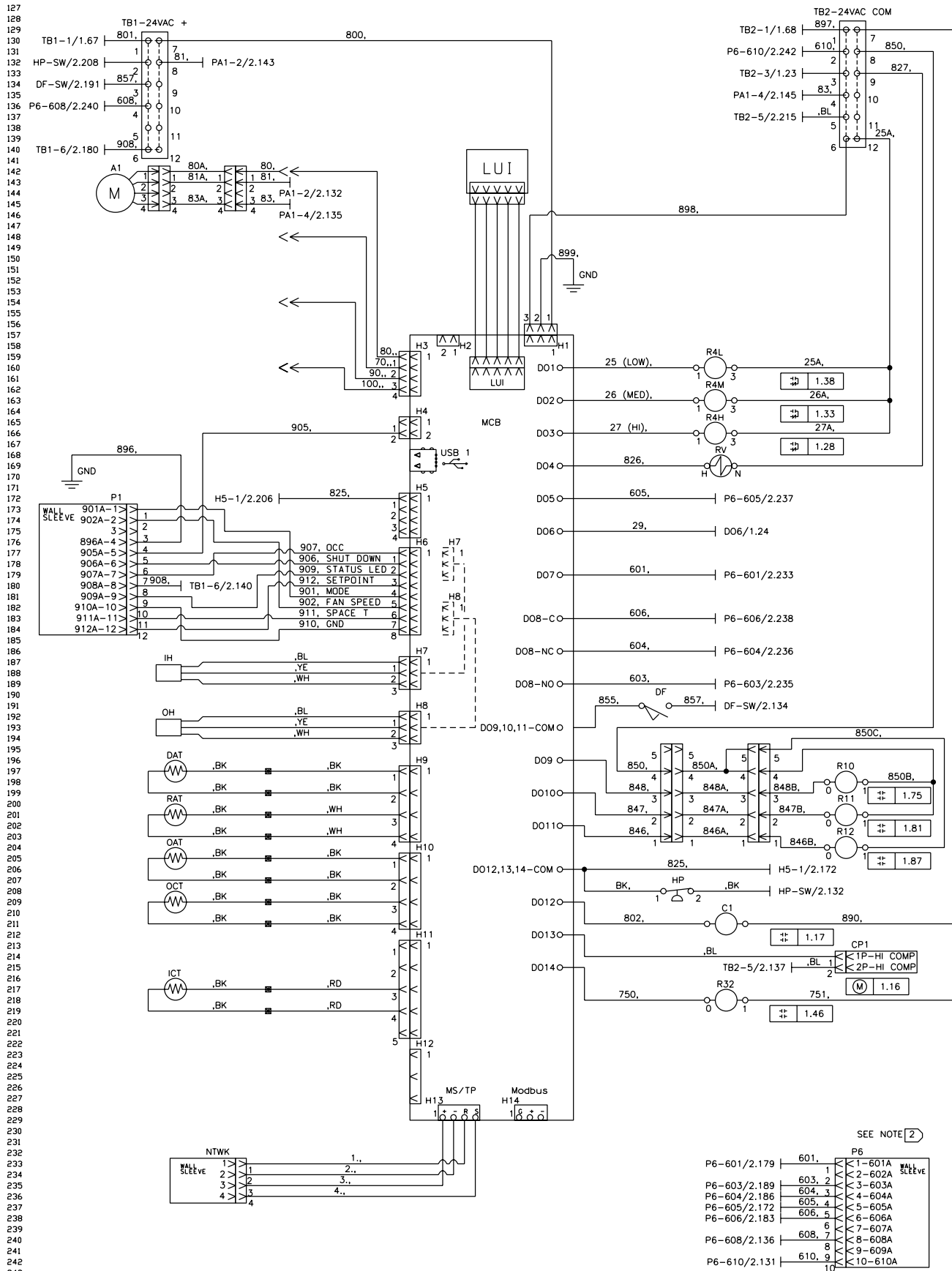

Note: See Figure 33 on page 60 for typical MicroTech service and disconnect wiring and wiring schematic legend.

Typical MicroTech Wiring Diagram – Service and Disconnect 208V / 60Hz / 1Ph

Figure 33: Typical MicroTech Wiring Diagram – Service and Disconnect – 208V / 60Hz / 1Ph

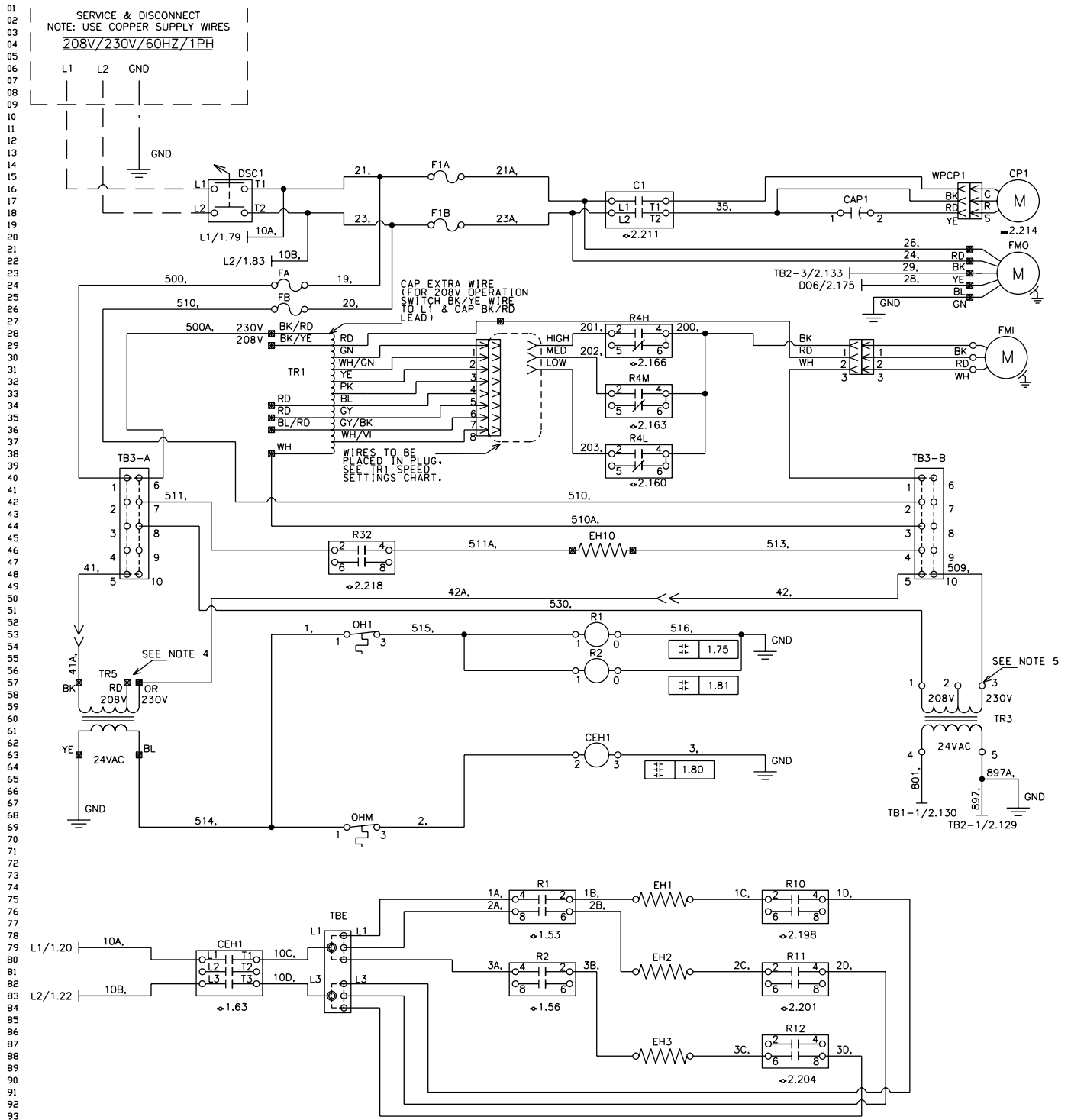

Legend - Symbols	
---	Accessory or field mounted component
⏏	Ground
⊗	Wire nut / splice
●	Overlap point - common potential wires
L1/1.20	Wire link (wire link ID / page # . line #)

TR1 Speed Settings		
	044	036
High	GN	GN
Med	YE	PK
Low	PK	GY

Typical Wall Sensors Diagram

Figure 34: Wall-Mounted Temperature Sensor Wiring for Wall Sensor

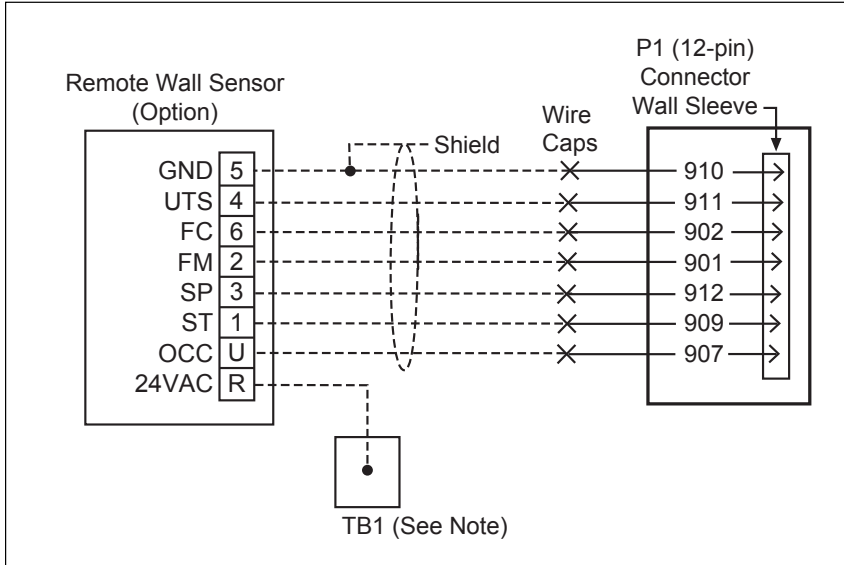

Note: The "R" terminal is used only with sensor part numbers 910247458 (6-button) and 910247448 (4-button).

Power & Control Field Wiring

Figure 35: External Input Wiring Examples with or without Daisy Chaining of Units

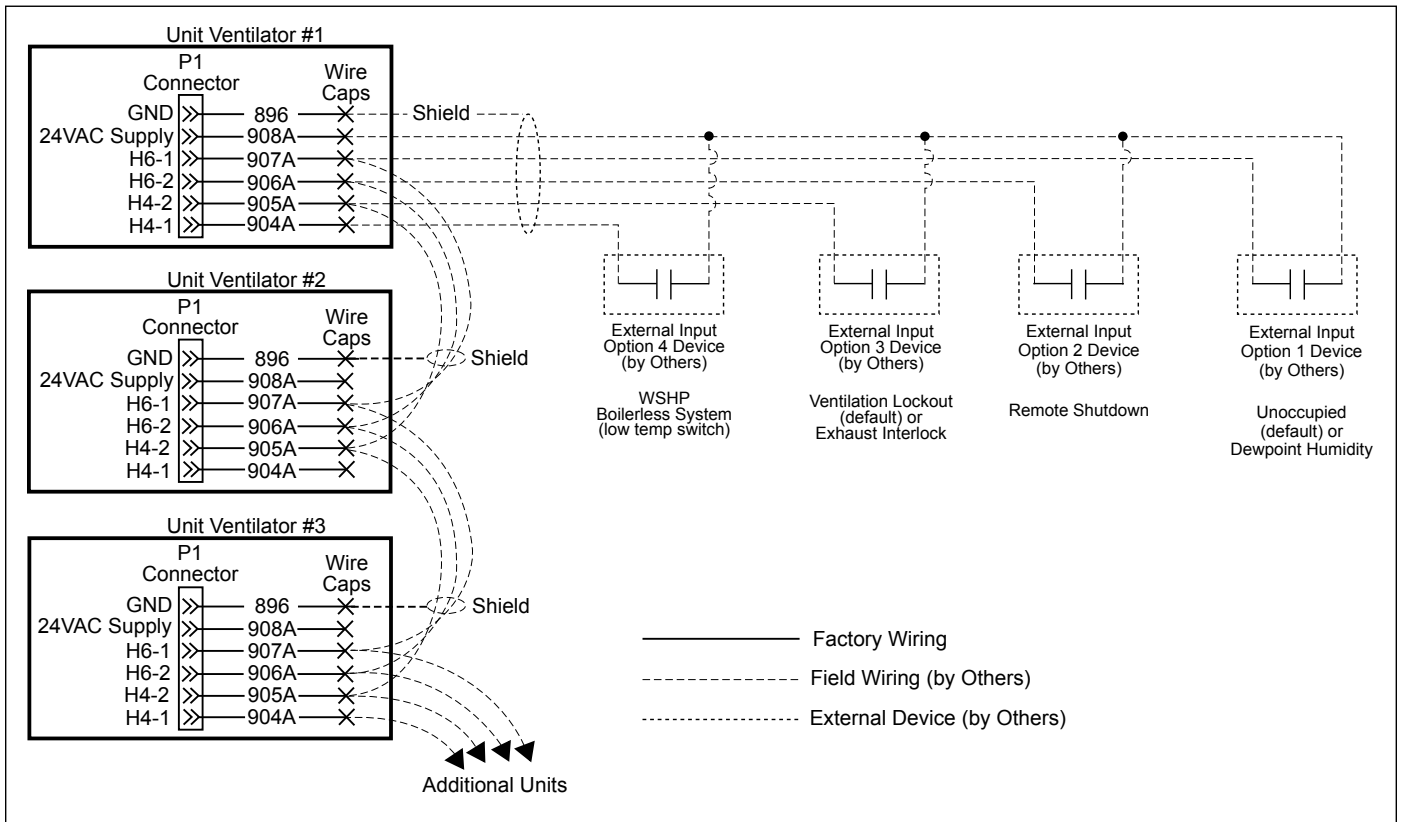

Figure 36: External Output Wiring - Single Unit

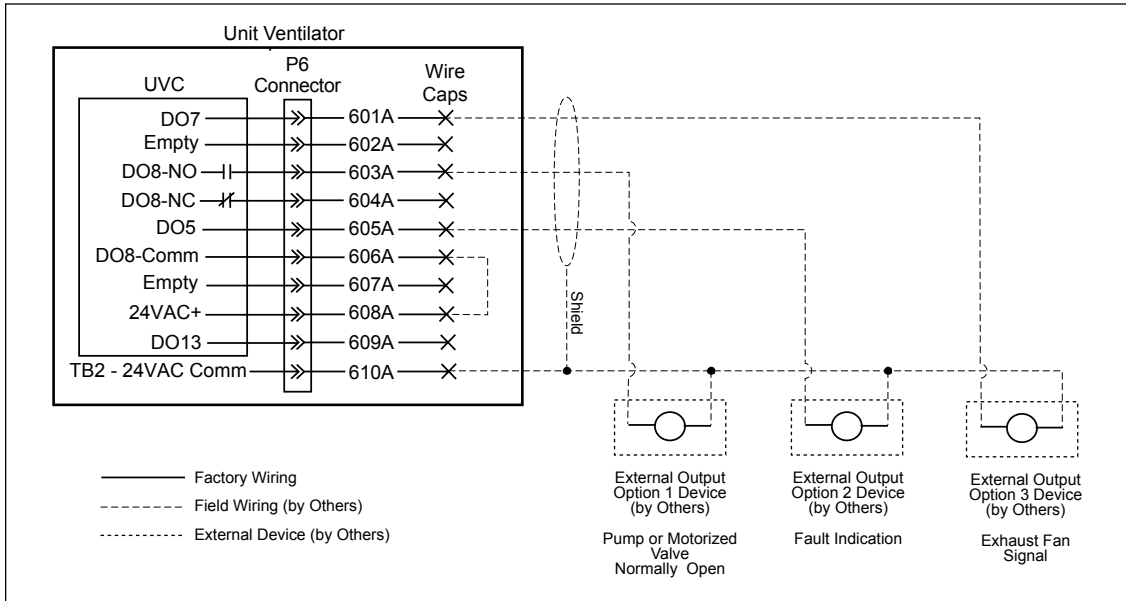
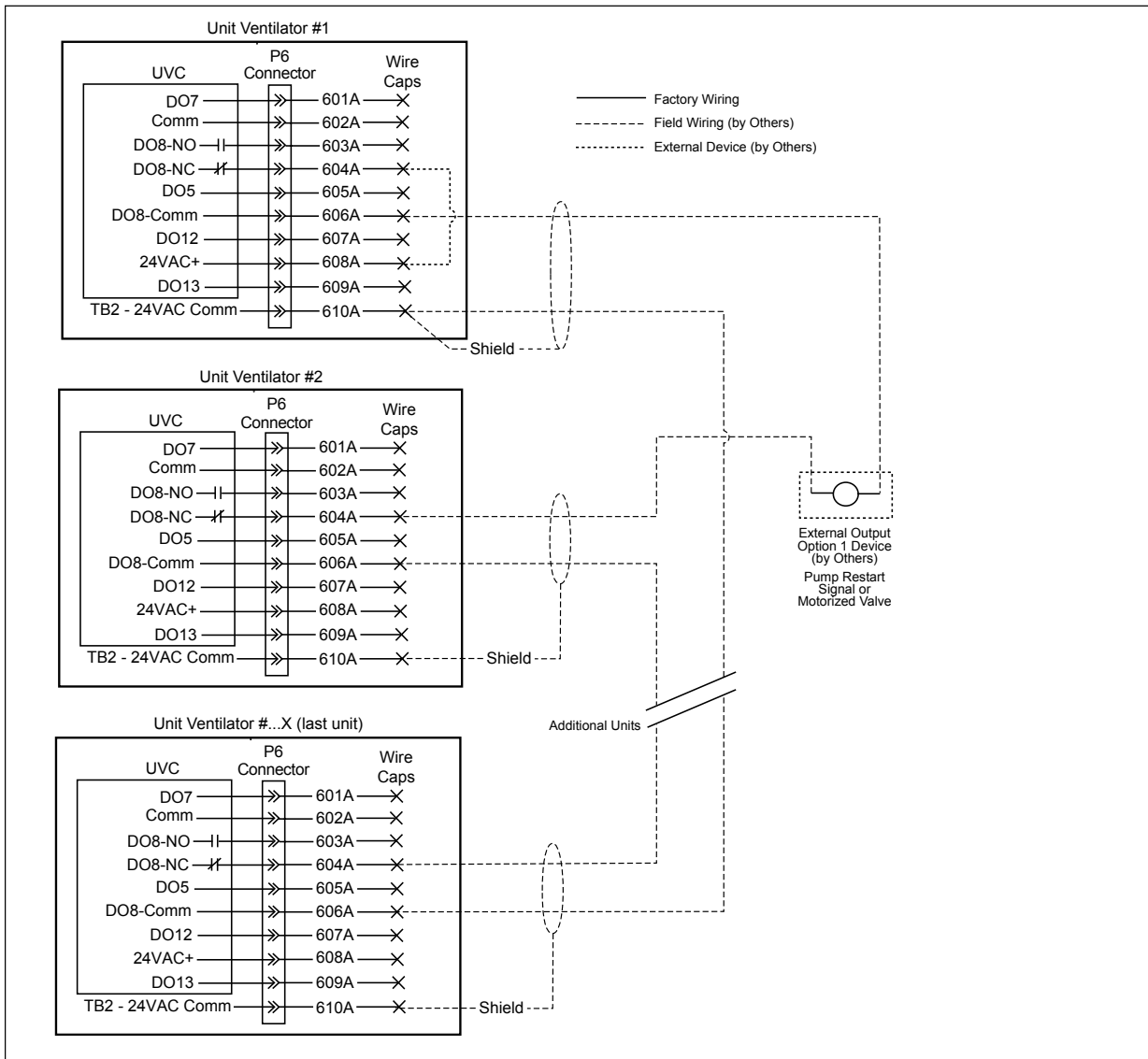
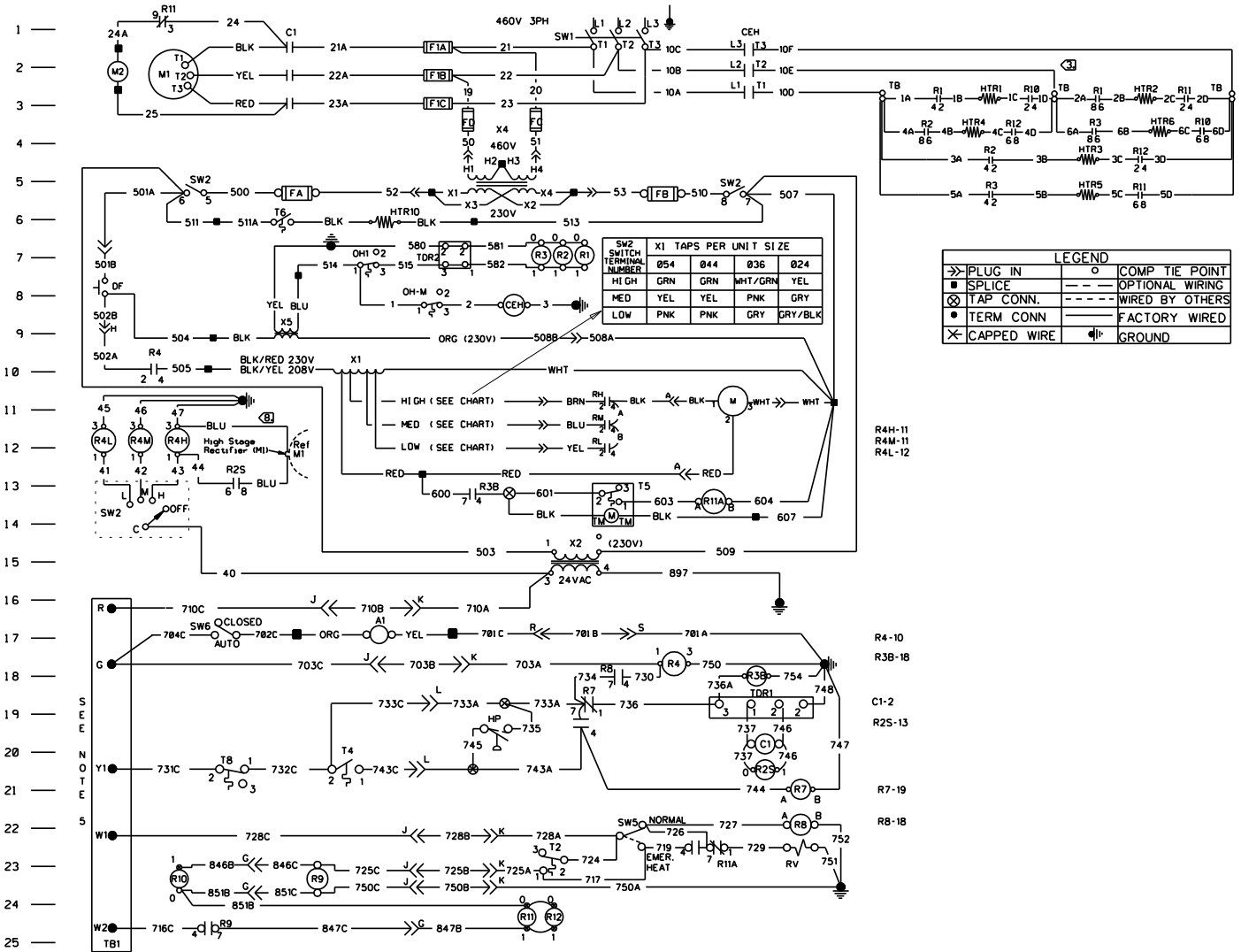

Figure 37: External Output Wiring - Multiple Units Shown



Electromechanical Control

Figure 38: AEQ Electromechanical Control



Note: For troubleshooting, refer to unit-mounted schematic. See Table 12 on page 64 for wiring diagram legend and notes.

Table 12: Wiring Diagram Legend for Figure 38 on page 63

Symbol	Description	Line No.	Symbol	Description	Line No.
A1	Actuator- Outdoor Air	20	R4M	Relay- Medium Fan Speed (Coil 24 VAC)	12
C1	Contacto- Compressor	20	R4L	Relay- Low Fan Speed (Coil 24 VAC)	12
CEH	Contacto- Electric Heat	10	R10/12	Relay- Main Electric Heat	24
DF	Dead Front Switch	12	R11A	Relay- Defrost	13
FA/FB	Fuse- Control	9	RV	Reversing Valve	23
F1A/F1C	Fuse- Compressor	2.5	SW1	Switch- Disconnect	2
HP	Switch- High Pressure (600 psi)	20	SW2	Switch- ON-OFF, Fan Speeds	9
HTR1/6	Heater- Electric Heat	4	SW5	Switch- Emergency Heat	22
HTR10	Heater- Drain Pan	6	SW6	Switch- Ventilation Opt	17
M	Motor - Room Fan	12	TB1	Terminal Board- Control	20
M1	Compressor (2 Stage)	3	TDR1	Relay- Time Delay Compressor (20.5V)	19
M2	Condensing Motor	3	TDR2	Relay- Time Delay Electric Heat (20.5V)	9
OH1	Overheat Electric Heat	9	T2	Thermostat- Electric Heat Relay OA Temp > 20°	23
OH-M	Overheat Electric Heat Manual Reset	11	T4	Thermostat Low Temp (28°F)	21
R1/3	Relay- Backup Electric Heat	9	T5	Thermostat- Defrost	13
R2S	Relay High (2nd) Stage Compressor	18	T6	Thermostat- Low Limit	12
R3B	Relay- Defrost / Electric Heat Coil 24VAC	18	T8	Thermostat- Cooling Lockout 59°	20
R7	Relay Compressor Lockout	21	X1	Transformer- Motor	12
R8	Relay- Changeover Coil 24VAC	22	X2	Transformer- Control 50VA	15
R9	Relay- Emergency Heat	23	X4	Transformer- 460/120V	6
R4	Relay- Fan (Coil 24 VAC)	17	X5	Transformer- 40VA Backup Relays	11
R4H	Relay- High Fan Speed (Coil 24 VAC)	12			

- Notes:**
- All electrical installation must be in accordance with national and local electrical codes and job wiring schematic.
 - NEC Class 1 wiring factory mounted night controls connect to Blk & Wht wires. When remote night controls are used, they must be connected to Blk & Wht wires shown capped, and the Blk & Wht wires in the main control box must be disconnected and individually capped.
 - Terminal block (TB) furnished when total electric heat load is less than 48 amps.
 - Numbers along right side of schematic designate the location of the contacts by line number.
 - See control and thermostat drawing for additional controls.
 - SW2 contact 5, 6 and 7, **8 open only when SW2 is in OFF position.**
 - SW2 contacts H, M and L.
 - High (2nd Stage) compressor rectifier energized when compressor is ON and fan speed is on HIGH.

Control Modes and Functions

Daikin unit ventilators equipped with MicroTech controls can be programmed to operate in a variety of modes based on the current situation in the room and the status of the unit ventilator. Changes in mode can be triggered manually, via network signals, by sensor readings, or by date and time. External inputs and outputs can be used to change modes, communicate data to network controls or change the functional operation of the unit.

Occupancy Modes

MicroTech controls can be set up to change modes based on room occupancy. Four different occupancy modes are provided, as described below.

Occupied Mode

This is the normal daytime operation mode. The controller maintains a room set point using the outside air capability and other functions.

Note: For non-school applications, the unit can also be configured to cycle the fan in response to the room load. In this case, the fan would normally be in the Off Mode until heating or cooling is required. The outside air damper is always closed when the fan is off. When the fan starts, the outside air damper opens to the required position, usually minimum position.

Unoccupied Mode

This is the night setback operating mode, in which the unit responds to a new room set point and cycles to maintain the condition. The fan comes on when heating or cooling is needed and runs until the load is satisfied. The outdoor air damper is closed during this mode. When a cooling load is satisfied by a refrigerant system, the compressor is de-energized and the unit ventilator indoor fan continues to run for a fixed period of time to remove coldness from the evaporator coil.

Stand By Mode

In this mode, the unit maintains the occupied mode set point temperature with the outdoor air damper closed. The fan runs continuously unless it is configured to cycle in response to the load.

Bypass Mode

This is a tenant override operating mode initiated by using the optional LUI or by depressing the tenant override switch on the optional room sensor. The unit is placed back into occupied mode for a predetermined time (default 120 minutes). This time can be set in 1-minute increments from 1 minute to 240 minutes through the unit ventilator service tool or a network.

Economizer Modes

Economizer operation is facilitated by the outdoor air damper, which automatically adjusts the above-minimum outside air position to provide free cooling when the outdoor air temperature is appropriate. Three levels of economizer control are available:

Basic Economizer Operation

The MicroTech controller compares the inside and outside temperatures. If the temperature comparison is satisfactory, then free-air economizer operation is used to cool the space. Reheat units also come configured with an indoor humidity sensor.

Expanded Economizer Operation

In addition to comparing inside and outside temperatures, outdoor relative humidity is measured to calculate outside air enthalpy. Free economizer operation is used to cool the space. This helps to minimize the entrance of humid outside air.

Leading-Edge Economizer Operation

The MicroTech controller compares both indoor and outdoor temperatures and indoor and outdoor relative humidities to determine if free economizer operation can cool the space with non-humid outside air. This is a true enthalpy economizer.

Night Purge Mode

Under this mode, the unit is configured to purge the room space for one hour for various reasons (odor or fume removal, drying, etc.). During Night Purge the outside air damper is open full and the fan is run on high speed. No "normal" heating or cooling takes place (the emergency heat set point is maintained) and the exhaust fan, if the room is so equipped, is signaled to turn on.

Freeze Prevention Mode

This mode helps protect the unit ventilator from freezing air conditions. Control functions vary depending on the type of temperature control used by the unit, as follows:

Emergency Heat Mode

If the unit is left in a mode that does not normally allow heating (such as Off, Fan Only, Cool, or Night Purge) and the room temperature falls below 55°F, the unit will heat the space to above 55°F and then return to the previously set mode of operation. This mode of operation can be field configured and/or be disabled.

External Input Functions

The unit ventilator controller is provided with four (4) binary inputs that allow a single set of dry contacts to be used as a signal to it, and two (2) binary inputs that allow a 24VAC signal. Input signal choices are described below. Multiple units can be connected to a single set of dry contacts.

Note: *Not all of the functions listed can be used at the same time. The unit ventilator controller is provided with configuration parameters that can be adjusted to select which function will be used for these inputs where multiple functions are indicated below.*

Unoccupied Input Signal

This input signals the unit ventilator controller to go into unoccupied or occupied mode. When the contacts close, the unit ventilator controller goes into unoccupied mode; when the contacts open, it goes into occupied mode. Additional variables can affect occupancy mode and override this binary input. See "[Occupancy Modes](#)" on [page 65](#).

Remote Shutdown Input Signal

This input signals the unit ventilator controller to go into shutdown mode. When the contacts close, the controller goes into shutdown mode; when the contacts open, it returns to normal operation.

Ventilation Lockout Input Signal

This input signals the unit ventilator controller to close the outdoor air damper. When the contacts close (ventilation lockout signal) the controller closes the outdoor damper; when the contacts open, it returns to normal outdoor damper operation.

Exhaust Interlock Input Signal

This input signals the unit ventilator controller that an exhaust fan within the space has been energized. The controller then repositions the outdoor air damper to a user-adjustable minimum position. When the contacts close (exhaust fan on signal) the controller uses the value defined by the Exhaust Interlock OA Damper Min Position Setpoint as the new minimum outdoor air damper position regardless of the indoor air fan speed. When the contacts open, it returns to normal outdoor damper operation.

External Output Functions

The unit ventilator controller is provided with three (3) binary outputs to perform the functions described below. These are relay type outputs that supply 24VAC.

Note: *Not all of the functions listed can be used at the same time. The unit ventilator controller is provided with configuration parameters that can be adjusted to select which function will be used for these outputs when multiple functions are indicated below.*

Fault Signal

This relay output provides one set of Normally Open (NO) (reversible through keypad/software) 24VAC contacts that can be used to signal a fault condition. When a fault exists, the unit ventilator controller energizes this relay output. When the fault or faults are cleared, it de-energizes this relay output.

Exhaust Fan On/Off Signal

This relay output provides one set of Normally Open (NO) (reversible through keypad/software) 24VAC contacts that can be used to signal the operation of an exhaust fan. When the outdoor air damper opens more than the Energize Exhaust Fan OA Damper Setpoint, the relay output will signal the exhaust fan on (contacts closed). When the outdoor damper closes below this setpoint, the relay output will signal the exhaust fan off (contacts open).

Auxiliary Heat Signal

This relay output provides one set of Normally Open (NO) (reversible through keypad/software) 24VAC contacts that can be used to operate an auxiliary heat device. The unit ventilator controller by default is configured to operate a NO auxiliary heat device (de-energize when heat is required) such as a wet heat valve actuator with a spring setup to open upon power failure. However, the Auxiliary Heat Configuration variable can be used to set the controller to use an NC auxiliary heat device (energize when heat is required) such as electric heat.

Advanced Control Options

MicroTech controls make possible a number of advanced control options that can quickly pay for themselves in saved energy costs and more comfortable classrooms, as described below.

Part Load Variable Air Control

Part Load Variable Air control can be used to automatically adjust the unit ventilator fan speed based upon the room load and the room-temperature PI control loop. This MicroTech control option provides higher latent cooling capabilities and quieter operation during non-peak load periods by basing indoor fan speed upon room load.

During low-load or normal operation (about 60% of the time) the fan will operate on low speed. When the load increases to an intermediate demand, the fan will automatically shift to the medium-speed setting. Under near-design or design-load conditions, the fan will operate on high speed. A built-in, 10-minute delay helps minimize awareness of fan speed changes. Low-speed fan operation under normal operating conditions, in conjunction with our GentleFlo fan technology contributes to a very quiet classroom environment.

Demand-Controlled Ventilation (Optional)

Daikin unit ventilators can be equipped to use input from a CO₂ controller to ventilate the space based on actual occupancy instead of a fixed design occupancy. This Demand Controlled Ventilation (DCV) system monitors the amount of CO₂ produced by students and teachers so that enough fresh outdoor air is introduced to maintain good air quality. The system is designed to achieve a target ventilation rate (e.g., 15 cfm/person) based on actual occupancy.

By using DCV to monitor the actual occupancy pattern in a room, the system can allow code-specific levels of outdoor air to be delivered when needed. Unnecessary over-ventilation is avoided during periods of low or intermittent occupancy.

With DCV you can be confident that your school is meeting ventilation standards for Indoor Air Quality and that your students are receiving adequate air to be attentive to instruction. At the same time, you are saving money in early morning hours, in between classes, or after hours when classrooms are heated and cooled but not always fully occupied.

Acceptance by Codes and Standards

ASHRAE Standard 62-2004 Ventilation for Indoor Air Quality recognizes CO₂ based DCV as a means of controlling ventilation based on occupancy. The ASHRAE standard has been referenced or adopted by most regional and local building codes. This standard references ventilation on a per-person basis.

Using CO₂ control will sometimes lower the absolute amount of outside air delivered into a room but will maintain the per-person rate. For example, if a classroom is designed for 30 students, the ventilation rate is 450 cfm (30 students × 15 cfm/student). However, when there are only ten students in the classroom, the CO₂ control will adjust ventilation to 150 cfm (10 students × 15 cfm/student). A minimum base ventilation rate (typically 20% of design levels) is provided when in the occupied mode. This provides outdoor air to offset any interior source contamination while allowing for proper space pressurization.

DX System Control

The unit ventilator controller is configured to operate the compressor as secondary (mechanical) cooling when economizer cooling is available, and as primary cooling when economizer cooling is not available. Additional DX control features include:

Compressor Cooling Lockout

The unit ventilator controller is configured to lock out compressor cooling when the outdoor air temperature falls below the compressor cooling lock out setpoint. Below this temperature setpoint only economizer cooling will be available.

Minimum On and Off Time

The unit ventilator controller is provided with minimum-on and minimum-off timers to prevent adverse compressor cycling (3-minutes default).

Compressor Start Delay Variable

This variable is intended to be adjusted as part of the start-up procedure for each unit. It is used to prevent multiple unit compressors from starting at the same time after a power failure or after an unoccupied-to-occupied changeover. Each unit should be configured at start-up with a slightly different (random) delay, or groups of units should be provided with different delays.

System Components

The main components of the MicroTech system are:

- A Unit Ventilator Controller (UVC) with on-board BACnet MS/TP communication
- Optional Local User Interface (LUI)
- Optional LON plug-in network communication module
- In addition, unit ventilators equipped with MicroTech controllers feature factory-mounted sensors and actuators for system control and feedback.

Unit Ventilator Controller

The MicroTech UVC is a DDC, microprocessor-based controller designed to provide sophisticated comfort control of an economizer-equipped Daikin unit ventilator. In addition to normal operating control, it provides alarm monitoring and alarm-specific component shutdown if critical system conditions occur. Each UVC is factory wired, factory programmed and factory run-tested for the specific unit ventilator model and configuration ordered by the customer.

Figure 18: MicroTech Control Board

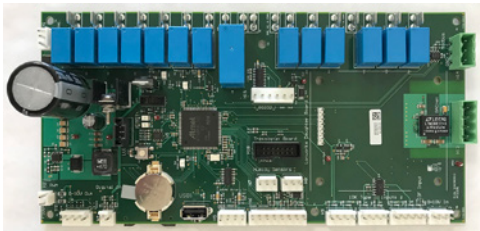

Local User Interface (Optional)

An optional built-in LUI touch pad with digital LED Display is located in the right hand compartment below the top right access door. The LUI features a 4 x 20 OLED digital display, 4 keys, and 2 individual LED indicators. In addition to the operating mode states and fan functions, the touch pad will digitally display:

- The room set point temperature.
- The current room temperature.
- Any fault code for quick diagnostics at the unit.

Figure 19: User Interface Touch Pad



The User Interface has individual touch-sensitive printed circuit board mounted buttons, and comes with a built-in menu structure (Password Protected) to change many of the common operating variables.

Four Operating Mode States

Four different user operating mode states can be chosen on the LUI:

Heat: Heating and economizer operation only.

Cool: Cooling and economizer operation only.

Fan Only: Fan only operation.

Auto: The unit automatically switches between heating, cooling and economizer operation to satisfy the room load conditions. The current unit state is also displayed.

Four Fan States

Four fan states are provided on all units: high, medium low and Auto speed modulation. The Auto speed function (part load, variable air) varies the fan speed automatically to meet the room load whether the unit is in heating, cooling or economizer mode.

All this is accomplished with a standard, single-speed NEMA frame motor. A built-in 10-minute delay helps minimize awareness of speed changes. During low-load or normal operation (about 60% of the time) the fan will operate at low speed. The low speed operation, along with GentleFlo fan technology, contributes to a very quiet classroom environment.

When the load increases to an intermediate demand, the fan automatically shifts to the medium speed setting. At near-design or design-load conditions the fan will operate on high speed.

With four fan states and GentleFlo fan technology, there is no need to oversize units or worry about uncomfortable conditions.

Communication Types

On-board BACnet communication or an optional LON communication module provide control and monitoring information to your building automation system without the need for costly gateways.

MicroTech Controller with BACnet MS/TP

The MicroTech® controller allows the UVC to inter-operate with systems that use the BACnet (MS/TP) protocol with a conformance level of 3. It meets the requirements of the ANSI/ASHRAE 135-2008 standard for BACnet systems.

LONWORKS SCC Communication Module

This module supports the LONWORKS SCC (Space Comfort Communication) profile number 8500-10. Unit controllers are LONMARK certified with this optional LONWORKS communication module.

MicroTech Control Sensor and Component Locations

Figure 39: MicroTech Control Sensor and Component Locations

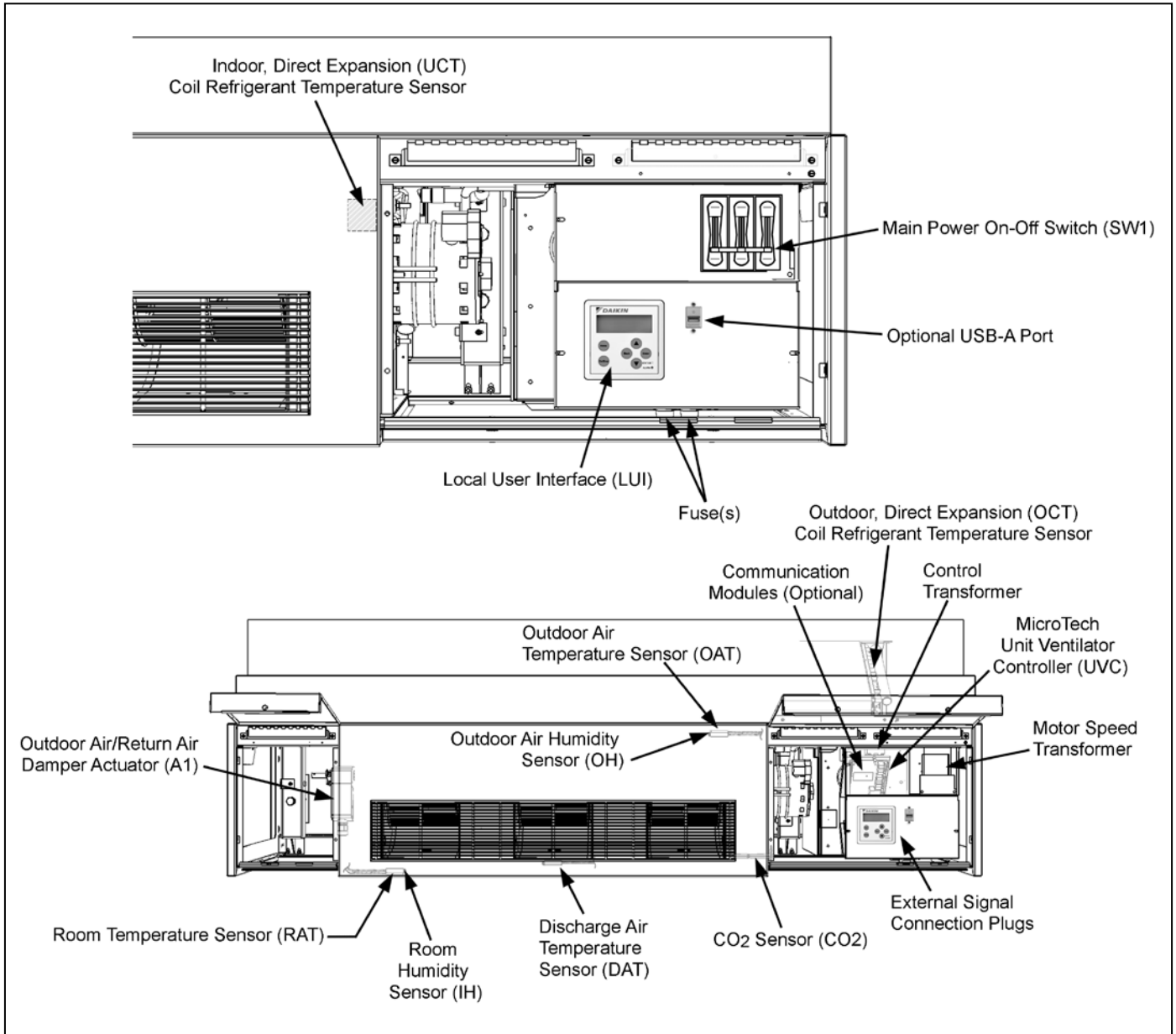

CO2 Sensor for Demand Controlled Ventilation

On units equipped for Demand Controlled Ventilation (DCV), the UVC is configured to use a 0-2000 PPM, 0-10 VDC, single beam absorption infrared gas sensor. CO2 sensors are available as unit mounted only. An air collection probe (pitot tube and filter) is installed in the return air of the unit (Figure 40).



Figure 40: CO2 Sensor For Demand Control Ventilation



Room Temperature Sensors used with MicroTech Unit Controls

Digitally Adjustable Display Sensor – 910247458

The display sensor is used in conjunction with MicroTech equipped units. This digitally adjustable sensor displays room temperature, fan speed (AUTO/HIGH/MEDIUM/LOW), system mode (HEAT/COOL/AUTO/OFF), ALARM, override and occupancy.

Digitally Adjustable Display Sensor – 910247448

The display sensor is used in conjunction with MicroTech equipped units. The sensor has a digital display for temperature, occupancy, alarm, setpoint and status indication. Controls include four buttons for setpoint, occupied/unoccupied request, and override reset.





Basic Room Sensor With Cool to Warm – 910247453

The basic room sensor with adjustment (cool to warm) is used in conjunction with MicroTech equipped units. The sensor has an output for temperature, and LED status indication and includes an override reset button.

Basic Room Sensor – 910247450

The basic room sensor is used in conjunction with MicroTech equipped units. The sensor has an output for temperature, and LED status indication and includes an override reset button.

Table 13: Room Temperature Sensors for BAS Operation

Room Temperature Sensors used with Unit Ventilator – Building Automated System (BAS) Operation		Digitally Adjustable Display Sensor	Digitally Adjustable Display Sensor	Basic Room Sensor With Cool to Warm Adjust	Basic Room Sensor
					
		Part No. 910247458	Part No. 910247448	Part No. 910247453	Part No. 910247450
Feature					
Setpoint Adjustment		Digitally Adjustable	Digitally Adjustable	Cool to Warm	None
Display	Room Temperature & Setpoint	●	●		
Operating Modes	System	Heat-Cool-Auto-Off-			
	Fan	Auto-High-Medium-Low			
	Occupancy	LCD Display of Occupied-Unoccupied Icon	LCD Display of Occupied-Unoccupied Icon		
Annunciation	Status LED	LCD Display of Unit Status	LCD Display of Unit Status	●	●
	LCD Alarm Display	●	●		
Reset	Alarm	●	●	●	●
	Setback Override	●	●	●	●

Actuators

Face & Bypass Damper Actuator

On units equipped with face & bypass damper control, the UVC is configured to operate a proportional, direct-coupled, face & bypass damper actuator. To increase accuracy, the controller has an overdrive feature for the 0% and 100% positions and a periodic (12-hour) auto-zero PI control loop for each modulating actuator.

Figure 41: Face & Bypass Actuator



Outdoor Air/Return Air Damper (OAD) Actuator

The UVC is configured to operate a proportional, direct-coupled actuator for the outdoor air damper. This actuator provides spring-return operation upon loss of power for positive close-off of the outdoor air damper. To increase actuator positioning accuracy, the UVC is provided with an overdrive feature for the 0% and 100% positions and a periodic (12- hour) auto-zero PI control loop for each modulating actuator.

Figure 42: Outdoor Air Damper Actuator



2-Position End-of-Cycle Valve Actuators (Optional)

On units equipped with 2-way or 3-way, end-of-cycle (EOC) valves, the UVC is configured to operate 2-position End-Of-Cycle (EOC) valve actuators (Figure 43). Spring return actuators are used for all End of Cycle (EOC) valves. All wet heat and heat/ cool EOC valves are normally open, and all cooling EOC valves are normally closed.

Figure 43: End of Cycle Valve Actuator



Modulating Valve Actuators (Optional)

On units equipped with modulating valves, the UVC is configured to operate proportional actuators for modulating 2-way and 3-way valves (Figure 44).

Figure 44: Modulating Valve Actuators



A Wide Variety of Input, Output & Alarm Data Points Available

A wide variety of data is available from Daikin Applied unit ventilators when equipped with MicroTech unit controllers in a network situation. They provide a clear

picture of just what's happening in each classroom and notify your building automation system of alarm conditions regardless of the protocol you select. [Table 14](#) below shows a list of inputs, outputs and alarm functions available.

Table 14: Network Operation -Typical Data Points¹

Read/Write Attributes	Read Only Attributes	Read/Write Setpoint Attributes	Typical Alarms
<ul style="list-style-type: none"> • Application Mode • Compressor Enable • Emergency Override • Energy Hold Off • Heat/Cool Mode • Occupancy Override • Outdoor Air Humidity • Outdoor Air Temperature • Reset Alarm • Reset Filter Alarm • Source (Water In) Temperature • Space CO₂ • Space Humidity • Space Temperature • Economizer Enable • Heating Setpoint Shift • Cooling Setpoint Shift 	<ul style="list-style-type: none"> • Binary Input Status • Binary Output Status • UV Software Application Version • Compressor Run Time • Chiller Water Valve Position • Discharge Air Temperature • Discharge Air Temperature Setpoint • Effective Setpoint • Fan Speed • F & BP Damper Position • Outdoor Air Damper Position • Space Fan Runtime • Unit Ventilator Controller State • Water-Out Temperature • WH or CW/HW Valve Position • OA Minimum Position 	<ul style="list-style-type: none"> • Econ. IA/OA Enthalpy Differential Setpoint • Econ. IA/OA Temp. Differential. Setpoint • Econ. Outdoor Air Enthalpy Setpoint • OAD Min. Position Low-Speed Setpoint • OAD Min. Position Med.-Speed Setpoint • Occupied Cooling Setpoint • Occupied Heating Setpoint • Space CO₂ Setpoint • Space Humidity Setpoint • Standby Cooling Setpoint • Unoccupied Cooling Setpoint • Unoccupied Heating Setpoint 	<ul style="list-style-type: none"> • Indoor Air Temperature Sensor Failure • DX Pressure Fault • Indoor Air Coil DX Temperature Sensor Failure • Outdoor Air Temperature Sensor Failure • Discharge Air Temperature Sensor Failure • Outdoor Air Coil DX Temperature Sensor Failure (or) • Water Coil DX Temperature Sensor Failure • Water-Out Temperature Sensor Failure (or) • Water-In Temperature Sensor Failure • Space Humidity Sensor Failure • Outdoor Humidity Sensor Failure • Space CO₂ Sensor Failure • Source Temperature (Water-In) Inadequate Indication • Change Filter Indication

¹ Not all data points or alarms listed will be available in all unit ventilator configurations. Humidity and CO₂ points require the use of optional sensors.

ServiceTools™

ServiceTools for MicroTech Unit Ventilators is software for operation on a personal computer. This software provides representation of the sequence of operation and enables the service technician to:

- Monitor equipment operation
- Configure network communications
- Diagnose unit operating problems
- Download application code and configure the unit

This software is a purchased tool for service technicians and will run on PCs with Microsoft Windows, Windows 7 and newer operating systems.

This tool provides more capabilities than the unit's user interface touch pad and is highly recommended for startup and servicing. (It may be required for startup and/or servicing, depending upon unit integration and other requirements.) It does not replace BAS functions, such as system wide scheduling or sequencing, and it cannot serve as a Work Station Monitoring package. ServiceTools interfaces with the MicroTech controller using serial communications through a USB type A connector.

Setpoints and Configuration Parameters

The UVC can save a snapshot of all setpoints and configuration parameters in the controller. Those configurations and setpoints can be saved onto a SD flash memory card, ensuring the controller can be reverted to those settings at a later date. Additionally, the settings saved to a SD can be taken to another UVC and loaded into it. Certain parameters, such as BACnet addressing and location, can be optionally restored to prevent duplication.

Data Trending

Data can be written to an optional SD card inserted into the control unit. The parameters that can be trended through MicroTech can be found in OM 732. Six options for trending frequency are available:

- None
- 10 Minutes
- Occupancy Change
- Hourly
- 1 Minute
- Daily

A separate trend file will be created of each day. If a "Daily" trend is selected, the trend file will contain a header and 1 line of data. If an "Hourly" trend is selected, the trend file will contain a header and 24 lines of data. The last 3 alarms in the Alarm History are always recorded.

Why Classrooms Overheat

Overheated classrooms occur every day in schools in every area of the country. The most serious result is their detrimental effect on students' ability to concentrate and learn. Research has determined that the ability to learn and retain knowledge decreases rapidly as the temperature exceeds recommendations. Overheated rooms also represent wasted fuel, resulting in excessive operating costs.

Correcting an overheating problem in an existing building is very difficult and expensive. It calls for redesign and alteration of the heating and ventilating system, necessitating considerable renovation. This potential problem should be recognized, understood and planned for when heating and ventilating systems are designed for new and existing buildings.

Schools Have Special Needs

Schools have unique heating and ventilating needs, in large part because of their variable occupancy and usage patterns. Fewer cubic feet of space is provided per student in a school building than in any other type of commercial or public building. School classrooms are typically occupied only six hours a day, five days a week, for only three-fourths of the year, with time out for vacations. All in all, this represents approximately 15% of the hours in a year that a classroom is occupied.

To understand the overheating problem in schools, one must first realize that the excess heat comes from what is commonly termed "uncontrolled heat sources." To gain some perspective on how this affects heating and cooling decisions, let's take a look at a typical classroom in the northern section of the mid western United States.

Suppose we have a classroom that is 24 by 38 feet with 10-foot ceilings and 100 square feet of window area along the outside wall. At an outside temperature of 0°F and a desired room temperature of 72°F, let's assume the normal amount of heat loss from the room to the outside is 55,000 BTUs per hour.

As the outside temperature changes, so does the amount of heat that the room loses. This is represented in Figure 45 by Room Heat Loss Line A, which ranges from 55,000 BTUs per hour at 0°F outside air temperature to zero BTUs at 70°F. Obviously, if the heating system were the only source of heat in the classroom, the solution would be simple: The room thermostat would cause the heating system to supply exactly the amount of heat required to maintain the room at the thermostat temperature setting. In reality, the introduction of excess heat from a variety of uncontrolled sources makes the challenge considerably more complex.

Figure 45: Heat Gain Vs. Heat Loss In Occupied Classrooms

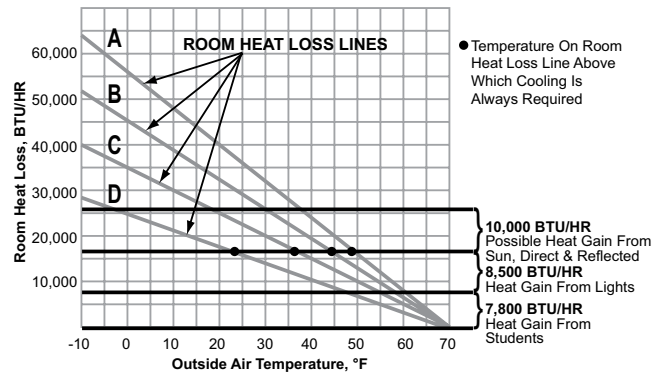

As Figure 45 illustrates, even in very cold weather an occupied classroom is more likely to require cooling than heating.

Heat From Students

Body heat generated by students in a classroom is one of the three primary sources of uncontrolled heat. In a typical classroom of 30 students, the amount of heat given off at all times will vary according to factors such as age, activity, gender, etc. A conservative estimate is 260 BTUs per hour per pupil. Multiply this by 30 and you get a total of 7,800 BTUs per hour added to the room by the students alone. This excess heat is noted in Figure 45 as "Heat Gain from Students."

Heat Gain From Lights

Heat emitted by the lighting system constitutes a second uncontrolled heat source. Artificial lighting is needed in most classrooms even during daylight hours to prevent unbalanced lighting and eye strain. A typical classroom requires approximately 2,500 watts of supplemental lighting to provide properly balanced lighting. Fluorescent lights add heat to the room at the rate of 3.4 BTU per watt per hour, or a total of 8,500 BTU per hour. This extra heat is represented in Figure 45 as "Heat Gain from Lights."

Add the heat gain from lighting to the 7,800 BTUs introduced by student body heat and we now have an extra 16,300 BTU/HR being introduced into the classroom by uncontrolled sources. This heat gain remains constant regardless of the outdoor air temperature.

Solar Heat Gain

The sun is a third uncontrolled source of heat. And, because it is neither positive nor constant, calculating its contribution to the overall heat gain is difficult. Solar heat gain can be the worst offender of the three in classrooms with large windows. Indirect or reflected solar radiation is substantial even on cloudy days, even in rooms with north exposure, as a result of what is termed "skyshine."

To get an idea of the potential effect of the sun, let's assume that the solar heat gain in our hypothetical classroom will peak at 240 BTU/HR per square foot of glass area. If we then assume a glass area of 100 square feet and at least 100 BTU/HR per square foot of glass for solar heat gain, we can calculate a very conservative estimate of 10,000 BTU/HR heat gain through windows. If we add this to the heat from the lights and body heat, total heat gain adds up to 26,300 BTU/HR from sources other than the heating and ventilating system. This is indicated in [Figure 45 on page 73](#) by the top horizontal line, which intersects Room Heat Loss Line A at approximately 37°F. This is a reasonable estimate of the maximum uncontrolled heat gain that can be received in the typical classroom from these common heat sources.

The Analysis

From [Figure 45 on page 73](#) it is evident that, at an outside temperature of 48°F or higher, the heat given off by 30 students and classroom lighting is sufficient to cause overheating. This is true even if the classroom is occupied at night when solar heat gain is not a factor. But, since classrooms are occupied during the day, solar addition provides heat in varying amounts even in classrooms with north exposures. Consequently, the heating and ventilating system in our typical classroom must provide cooling at all times when the outdoor temperature is above 48°F and at any time during colder weather when the solar heat gain exceeds room heat loss.

If we assume an average winter temperature of approximately 33°F in the region where our typical classroom is located, we know that, half of the time, both night and day, the outside temperature will be above 33°F. However, since it is generally warmer during the day, when school is in session, the heating and ventilating system will be required to provide cooling for this classroom during much of the time that the room is occupied.

In this example, we've assumed that our classroom had a room heat loss of 55,000 BTU/HR at a design outdoor air temperature of 0°F (Room Heat Loss Line "A"). Bear in mind, however, that the recent trend in "energy-saving" building design often results in rooms with lower room heat loss, as indicated by Room Heat Loss Lines "B," "C" and "D." At 0°F design outdoor air temperature:

- Room "B" has a room heat loss of 45,000 BTU/HR,
- Room "C" has a room heat loss of 35,000 BTU/HR,
- Room "D" has a room heat loss of 25,000 BTU/HR.

Note the lowering of the temperature above which cooling will always be required as the room heat loss decreases.

We've noted that cooling is always required in Classroom "A" when outdoor air temperatures exceed 48°F. In Classroom "B," "C," and "D" cooling is always required when outdoor temperatures exceed 44°, 36° and 23°F, respectively ([Figure 45 on page 73](#)).

Now that we understand the reason for classrooms overheating, the solution is simple: The heating and ventilating system must provide cooling to take care of the heat given off in the classroom by uncontrolled heat sources.

Cooling The Classroom

The Daikin Unit Ventilator has become a standard for heating and ventilating systems in schools because it provides the solution for overheating classrooms. The unit ventilator cools as well as heats. During the heating season the outdoor air temperature is nearly always below the desired room temperature. It stands to reason then that the outside air should be used to provide the cooling necessary to keep classrooms down to thermostat temperature.

The classroom unit ventilator does just that. By incorporating an automatically controlled outdoor air damper, a variable quantity of outdoor air is introduced in the classroom, metered exactly to counteract overheating. Since our problem is more one of cooling than of heating, it is evident that more than just the room heat loss must be determined to design a good heating and ventilating system. The cooling requirements should be assessed as well, and the free-cooling capacity of the equipment specified along with the heating capacity required. If this is done, the optimum learning temperature can be maintained in each classroom.

Meeting IAQ Requirements

Good indoor air quality (IAQ), which is important in the home and at work, is no less important to students and faculty in schools. For the past several years, efforts to reduce energy costs in new school buildings have seen the use of tighter construction, sealed windows and heavier insulation. While these construction techniques have helped reduce energy costs, tightly sealed buildings, or envelopes, when combined with increased use of recirculated air, have led to a condition known as sick building syndrome.

In a poorly ventilated school building, fumes and vapors from plastics and other synthetics are often not properly exhausted, while mold, fungus, and bacteria are able to flourish. These conditions can cause various ailments, including nausea, smarting eyes, and coughing, as well as increased student absenteeism and diminished productivity.

For these reasons, the American Society of Heating, Refrigeration and Air Conditioning Engineers (ASHRAE) now has recommendations for minimum ventilations rates for various types of classrooms and no longer endorses the practice of little or no usage of outdoor air.

Following ASHRAE Control Cycle II

ASHRAE Cycle II is a very economical sequence of control because only minimum amounts of outdoor air are heated and free outdoor air—natural cooling—is available to offset the large internal heat gain associated with the dense occupancy of classrooms.

Daikin unit ventilators are normally controlled according to ASHRAE Control Cycle II. ASHRAE control cycles apply only to heating, heating-and-ventilating and free-cooling operation. (For more information on the ASHRAE Control Cycle II sequence, see Figure 42 on page 33.)

Under ASHRAE Cycle II, the outdoor air damper is closed during warmup of the room. As the room temperature approaches the thermostat setting, the outdoor air damper opens to a predetermined minimum percentage of outside air. The heating coil capacity controller then modulates to maintain the thermostat setting.

If the room temperature rises above the thermostat setting, the heating coil is turned off and the outdoor air damper opens beyond the minimum position to maintain the thermostat setting.

EXAMPLE: For a 60°F entering air mixture temperature and 70°F room temperature, with 30°F outdoor air temperature, 25% outdoor air will produce the 60°F mixture air temperature. When the outdoor air temperature drops to 10°F, 12.5% outdoor air will produce the 60°F mixture air temperature.

Night Setback

Substantial fuel savings can be realized by operating the unit ventilator system at a reduced room setting at night and during other unoccupied periods, such as weekends and holidays. If the space temperature falls below the setting of the unoccupied thermostat, the unit fans will be brought on to provide additional heat. Units with electric heat coils do not provide convective heat. The electric coil and the unit fans will be brought on to maintain the thermostat setting.

Typical Temperature Control Components

In general, unit ventilators require the following basic DDC electrical components in order to operate on any of the standard unit ventilator ASHRAE cycles of control. The control components listed in this section are for familiarization purposes only and should not be construed as a bill of material.

Outdoor Air Damper Actuator

This is a modulating device under the control of the room and discharge sensors. It positions the outdoor air damper to admit the amount of outdoor air required at any given point in the control cycle. The room air damper is mechanically linked to the outdoor air damper, which permits the use of a single actuator. Electric actuators should be of the spring-return type so that the outdoor air damper closes whenever the electric power supply to the unit is interrupted.

Discharge Airstream Sensor

This device overrides the room sensor and modulates the outdoor air damper toward the closed position when the unit discharge air falls to a potentially uncomfortable temperature.

Electric Heat Step Control

A modulating step controller, under control of the room sensor, steps individual electric heating elements on and off as required. Staging relays are sometimes used in lieu of a step controller.

Additional Components

Additional components may be required depending on the specific application. They include:

Room Temperature Sensor Chamber:

When the Room Temperature Sensor is to be mounted within the unit ventilator rather than on the wall, it is located behind a series of holes in the unit front panel with the sensing element sealed within the room temperature chamber. The room temperature chamber is a standard feature with units furnished with MicroTech controls. All units come with a factory mounted room temperature sensor.

DX Cooling Low Ambient Lockout:

This lockout must be used on DX systems to lock out the condensing unit when the outdoor air temperature is below 64°F (17.5°C). This device must be integrated into the control system so that the unit has full ventilation cooling capability during the lockout period.

DX Low Temperature Limit:

This limit must be used on DX cooling units to de-energize the compressor when the refrigerant falls below freezing. DX units with MicroTech controls have a factory-installed sensor on the return bend of the DX coil that provides a sample of the coil's temperature.

Two Stage Compressors

Our self-contained units with the two-stage compressor will run on lower fan speeds up to 70% of the time, improving comfort through better humidity control and quieter operation, while minimizing issues with over sizing. The unit is designed to operate in low compression mode while in medium and low fan speed. The reduced cooling capacity in the medium and low fan speed will allow the system to run longer at moderate and low load conditions providing better humidity control. When the high capacity is needed the high speed will provide high compression and full capacity cooling.

Coil Selection

All coils have their own unshared fin surfaces (some manufacturers use a continuous fin surface, sacrificing proper heat transfer). The result is maximum efficiency of heat transfer, which promotes comfort and reduces operating costs.

An air break between coils in all Daikin units is used to enhance decoupling of heat transfer surfaces—providing full capacity output, comfort and reduced operating costs.

Direct expansion (DX) coils are constructed of aluminum fins with a formed, integral spacing collar. The fins are mechanically bonded to the seamless copper tubes by expansion of the tubes after assembly. Fins are rippled or embossed for strength and increased heat transfer surface.

Long Lasting Electric Heating Coils

With our draw-thru design, electric coils are directly exposed to the air stream. They come with a built-in switch to de-energize the coil when the center front panel is removed. A unit-mounted disconnect switch is included. A continuous electric sensory element for high temperature is not required because the air is drawn smoothly and evenly across the coils, prolonging life. (Blow-thru designs use cal rods inserted into the tube of a fin tube coil that results in reduced heat transfer. The constant movement of the electric heating cal rod within the tube shortens life.)

ASHRAE Cycle II

We strongly recommend that ASHRAE Cycle II be implemented with all unit ventilators using controls by others. ASHRAE Cycle II is a very economical sequence since only the minimum amount of outside air is conditioned and free natural cooling is available.

During warm-up (any classroom temperature 3°F or more below heating setpoint), the outdoor air damper is closed and the unit conditions only room air. As room temperature approaches the heating setpoint the outdoor air damper opens to a position that permits a predetermined minimum amount of outside air to be drawn in. Unit capacity is then controlled as needed to maintain room setpoints. If room temperature rises above room cooling setpoint, and the outside air is adequate for economizer cooling, then the outdoor air damper may open above the minimum position to provide economizer cooling.

ASHRAE Cycle II requires that a minimum of three temperature measurements be made:

1. Classroom temperature.
2. Unit discharge air temperature.
3. Outdoor air temperature.

Additionally, the control sequence should incorporate a Discharge Air Low Limit function which requires a discharge air temperature sensor and can override classroom temperature control in order to maintain a discharge air temperature setpoint of 55°F.

When the discharge air temperature drops below 55°F, the discharge-air low-limit function will disable cooling (if enabled) and modulate the unit's heating capability as needed to maintain the 55°F discharge-air setpoint regardless of room temperature.

If the unit's heating capability reaches 100%, then the discharge air low-limit function will modulate the outdoor air damper toward closed to maintain the 55°F discharge air setpoint. Outdoor air temperature is used to determine when to use economizer as a first stage of cooling, and when to use mechanical or hydronic cooling as the first stage of cooling.

Figure 46: ASHRAE Cycle II Operation

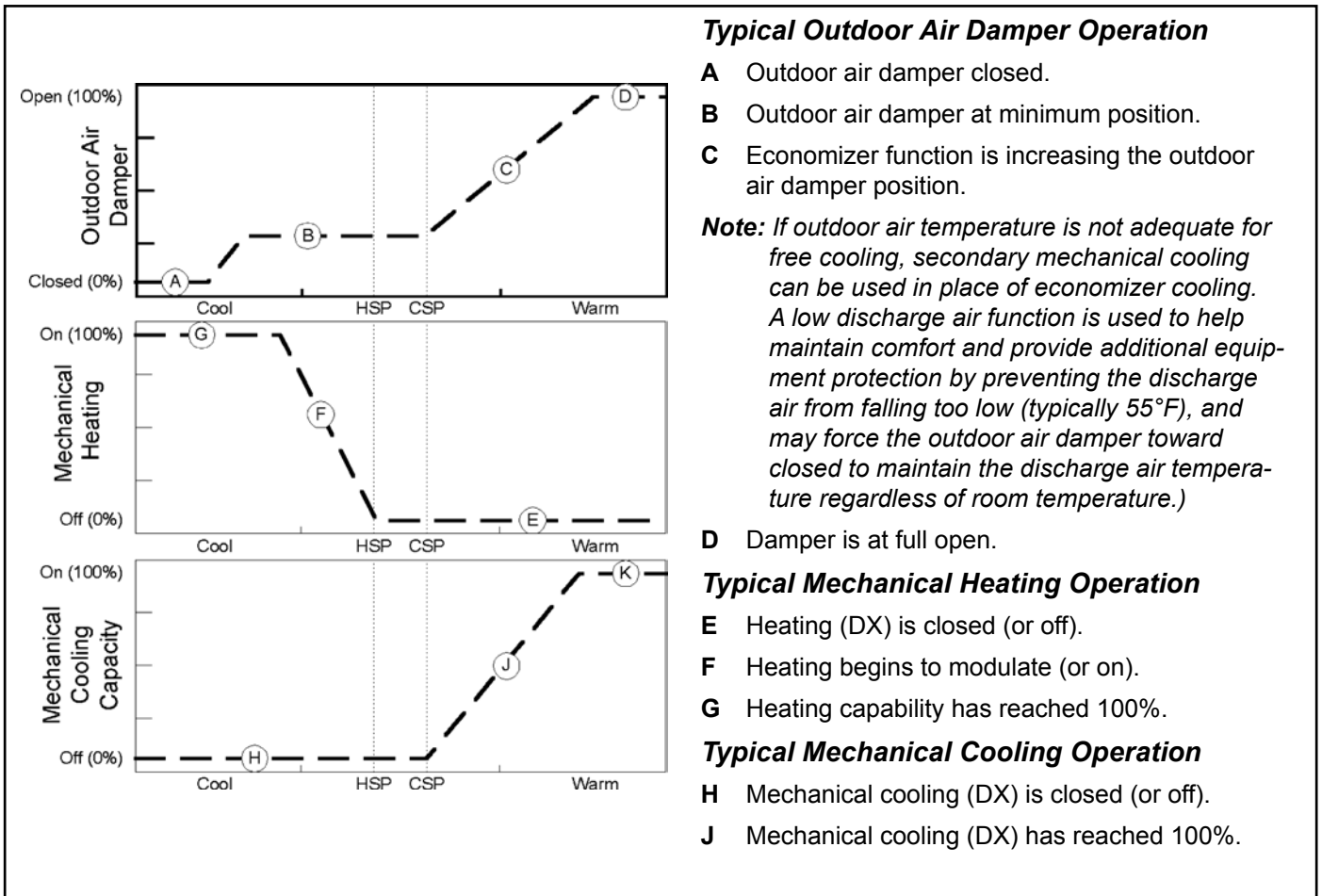

Unit Installation

Carefully arrange the location and installation of each model AEQ unit to provide convenient service access for maintenance and, if necessary, removal of the unit. The installation consists of four basic elements in the following order:

1. Louver
2. Galvanized Wall Sleeve
3. Horizontal Air Splitters by others (if required)
4. AEQ Self-contained Unit Ventilator

The louver brings in outdoor air for the condenser fan section and ventilation air to the classroom while providing a path for heated condenser air to exit.

The Wall Sleeve secures the unit, provides a watertight and air tight seal to the building and brings in electrical and control wiring (if required). It contains the unit main power disconnect switch which is located in the wall sleeve junction box. All field electrical connections are made inside this box.

Horizontal Air Splitters provide proper air paths and minimize air recirculation.

The AEQ self-contained unit ventilator provides comfort cooling and heating for the space. The Model AEQ unit is designed to be installed into or up against an exterior wall. The louver, air splitters (if required) and wall sleeve are installed before the AEQ unit is installed.

On many jobs, the louver and wall sleeve are shipped ahead of the unit itself. Installation instructions for these components are shipped with the individual components included in this publication.

The following are general instructions for suggested applications. In all cases, good engineering practices and local codes must be followed.

Figure 47: Typical Self-Contained Unit Ventilator Installation

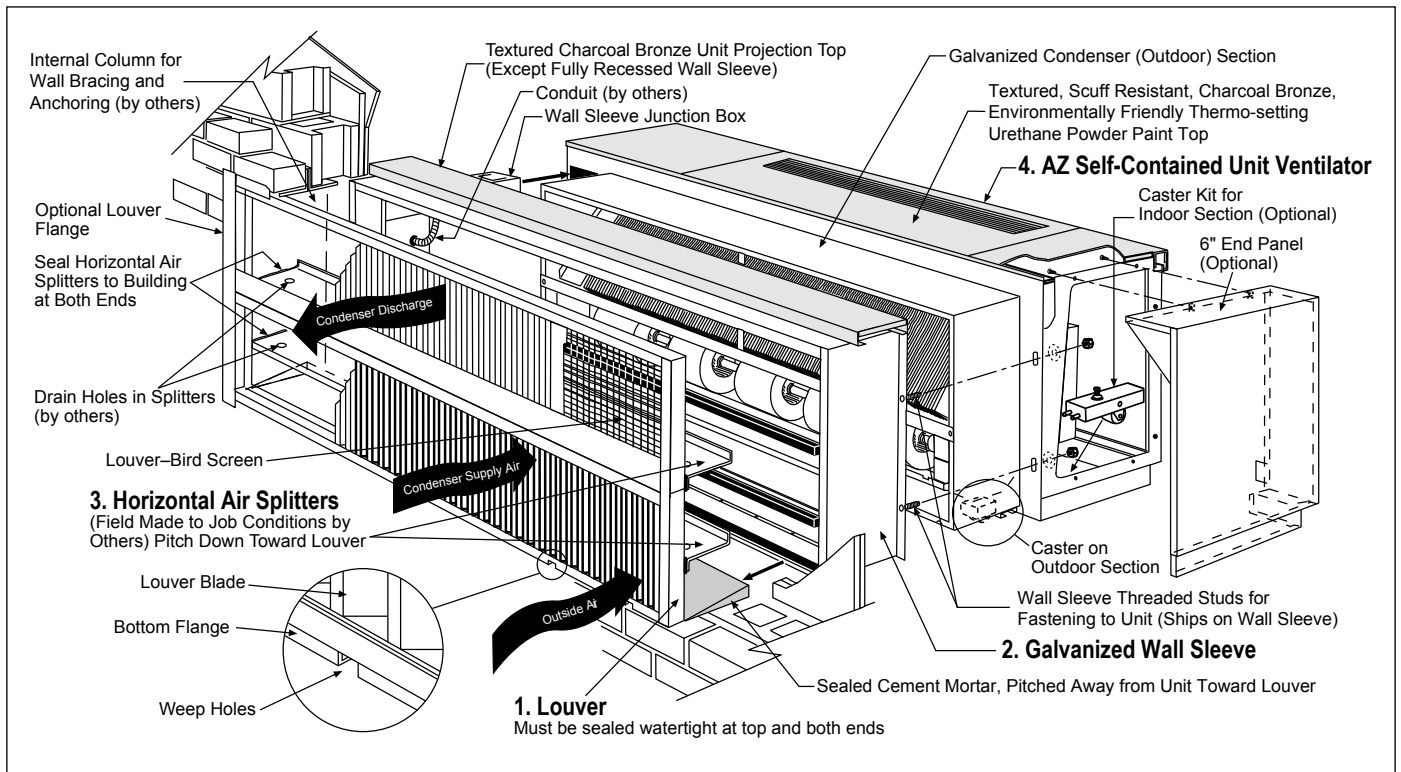

Wall Louvers

The outdoor air wall louver is usually set directly back of the unit ventilator. The position of the wall louver is determined in general by the building construction. The top of the lower channel of the louver frame should be at least 1/2" below the level of the inlet to the unit ventilator.

However, if a high intake opening is necessary, the top of this opening should be not more than 28" above the surface upon which the unit ventilator will set.

Figure 44: Wall Penetrations Detail

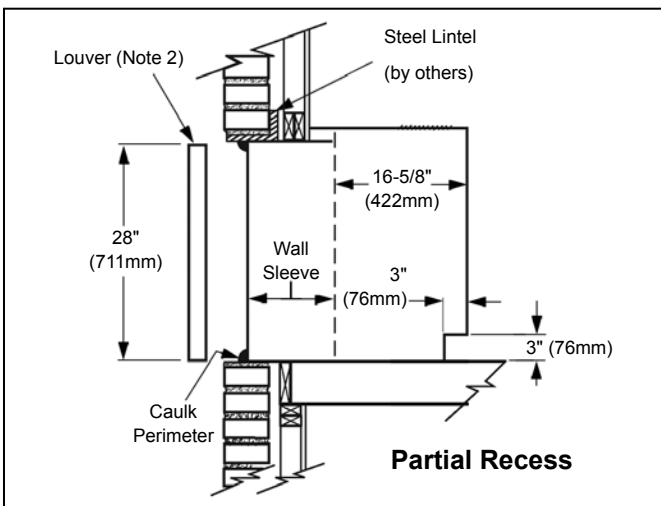
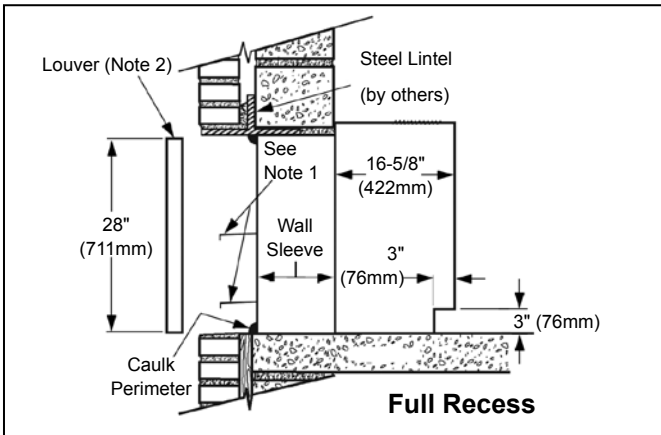

Notes:

1. Horizontal splitter (by others) must be installed whenever there is any space between the wall sleeve and the louver. It is necessary to seal the ends of the wall opening.
2. The top and two sides of the louver must be caulked water tight. The bottom edge of the louver must not be caulked, to allow for drainage.
3. Louvers may be recessed a maximum of 2" (51mm) from the exterior face of the wall.

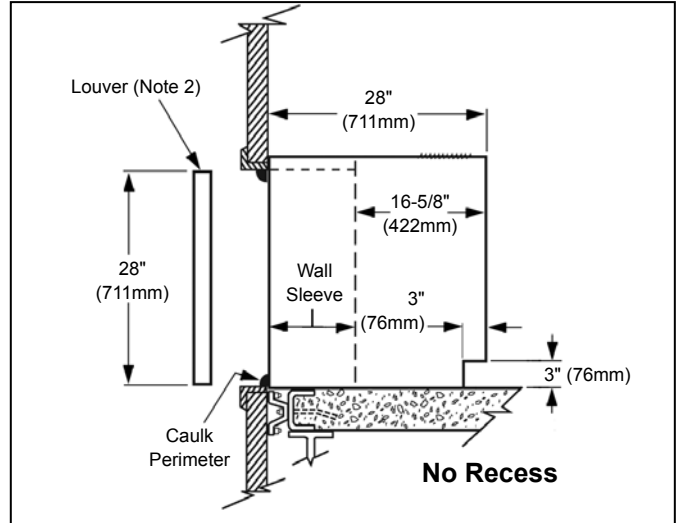

4. Drain must be flush with floor to allow unit installation and removal. Unit drain tube is 7/8" (22mm) O.D. copper.
5. A field-supplied air seal should be applied to the exterior perimeter of the wall sleeve when unit is installed with no recess.

Lintels

When brickwork is built up to the top of the intake, lintels must be used above the wall louvers. While the wall is still wet, finish the brick on the top, bottom and both sides of the intake opening with 1/2" cement mortar. With the standard location of the wall louver, the bottom of the intake opening must slope from the louver frame up toward the intake opening to a point 1" above the finished base of the unit.

If a metal sleeve connection is to be used between the unit ventilator and the wall louver, this sleeve must be installed after the unit ventilator is set, making a weather-tight connection to the unit ventilator cabinet. Turn the sleeve over the edge of the louver frame by proper peening before the louver is finally installed.

Figure 45: Typical Wall Opening with Lintels

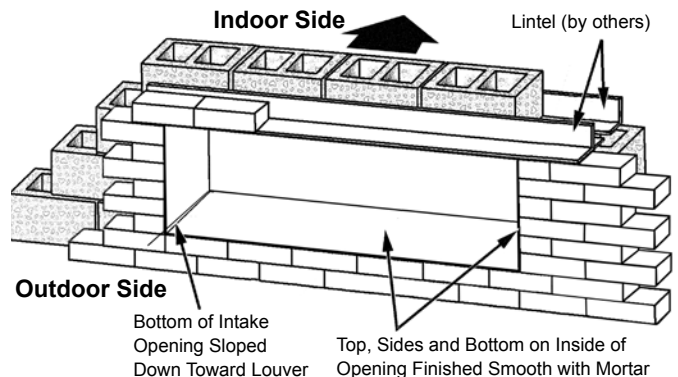

Horizontal Splitters & Unit Recess Details

Horizontal splitter (by others) must be installed whenever there is space between the wall sleeve and the louver. Seal the ends of the wall opening to prevent water penetration and air leakage. Pitch the splitters toward the louver for water drainage

Figure 48: 16-5/8" Room Projection or Full Recess

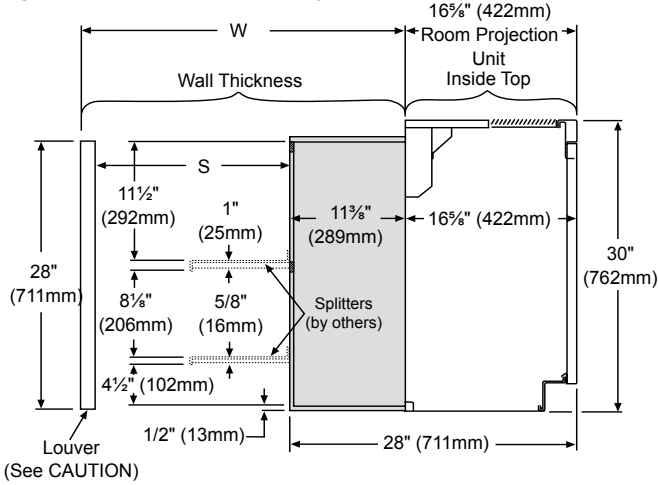

Note: Shading indicates portion of unit wall sleeve recessed into wall opening

Figure 49: 19-5/8" Room Projection

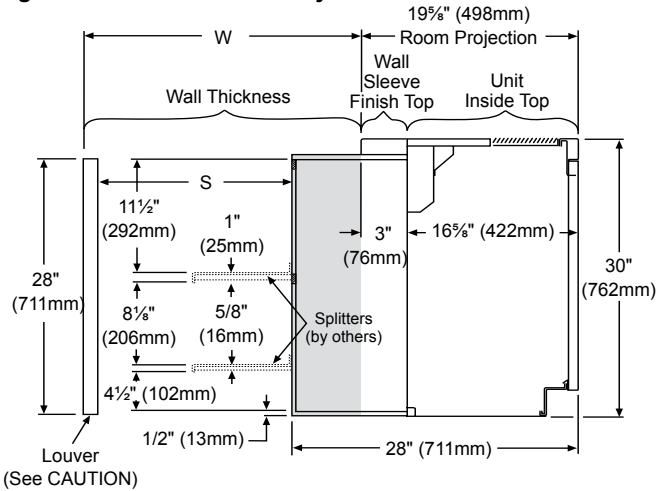

Note: Shading indicates portion of unit wall sleeve recessed into wall opening

CAUTION

Horizontal splitter (by others) must be installed whenever there is space between the wall sleeve and the louver. Seal the ends of the wall opening to prevent water penetration and air leakage. Pitch the splitters toward the louver for water drainage

Figure 50: 21-7/8" Room Projection

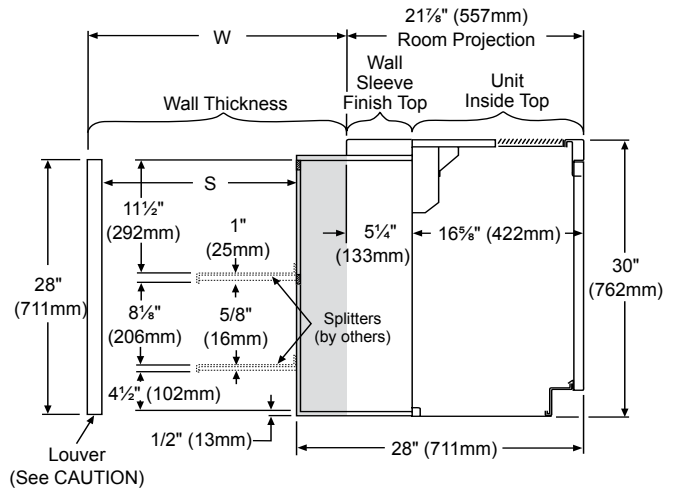

Note: Shading indicates portion of unit wall sleeve recessed into wall opening

Figure 51: 28" Room Projection

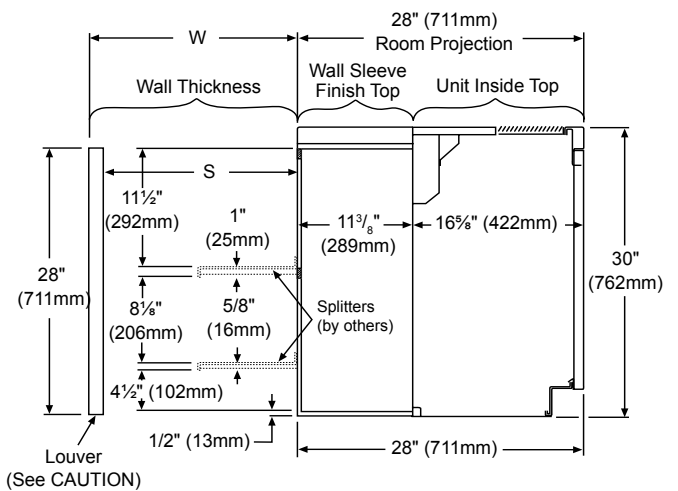

Table 15: Wall Thickness, Unit Projection Into Room

Wall Thickness "W"	Louver	Unit Projection into Room and Wall Sleeve Type			
		28"	21 7/8"	19 5/8"	16 5/8"
		Figure 51	Figure 50	Figure 49	Figure 48
Splitter Length from Wall Sleeve to Louver "S"					
2 1/2"		0"			
4"		1 1/2"			
6"		3 1/2"			
8"		5 1/2"			
8 5/8"		6 5/8"	0"		
10"		7 1/2"	1 5/8"		
10 7/8"	2 1/2"	8 3/8"	2 1/4"	0"	
12"		9 1/2"	3 3/8"	1 5/8"	
13 7/8"				3"	0"
14"				3 5/8"	1/8"
16"					2 5/8"
18"					4 1/8"
24"					10 5/8"

Note: All dimensions are approximate and subject to change without notice. Actual building dimensions may vary.

Interior Considerations

The interior wall surface behind the unit ventilator must be smooth and level. A wall that is slightly out of plumb can cause major problems with outside air leakage into the room and unit. This could cause drafts and potentially freeze coils.

Be certain that no gap is left between the unit and the outside air louver opening. Otherwise, outside air can leak into the room.

A rubberized, self-adhering membrane around the outside air opening can be used to seal any air or water leaks that might result from construction. Provide a seal under the unit to prevent air infiltration. In addition, seal the unit top and side perimeters to prevent unnecessary air infiltration due to uneven walls.

Indoor Air Exhaust Considerations

All outdoor air introduced by the unit ventilator must leave the room in some way. In some states, exhaust vents are required by law. In states where vents are not required by law, a decision must be made about how best to handle this problem.

The venting system chosen should have the ability to exhaust varying amounts of air equal to the amount of outside air introduced by the floor unit ventilator. A constant volume system, such as a powered exhaust, is unable to respond to changing conditions. It will either exhaust too much air, resulting in a negative pressure, which draws in more outdoor air than desired. Or, it will exhaust too little air, resulting in increased positive pressure, which restricts the amount of outside air being brought into the room.

The Daikin Ventimatic shutter is a more economical solution to the problem. See "Accessories" on page 21 for information on this system and its proper installation.

Wall Sleeve Arrangements

Figure 52: Recessed Wall Sleeve with Horizontal Air Splitters

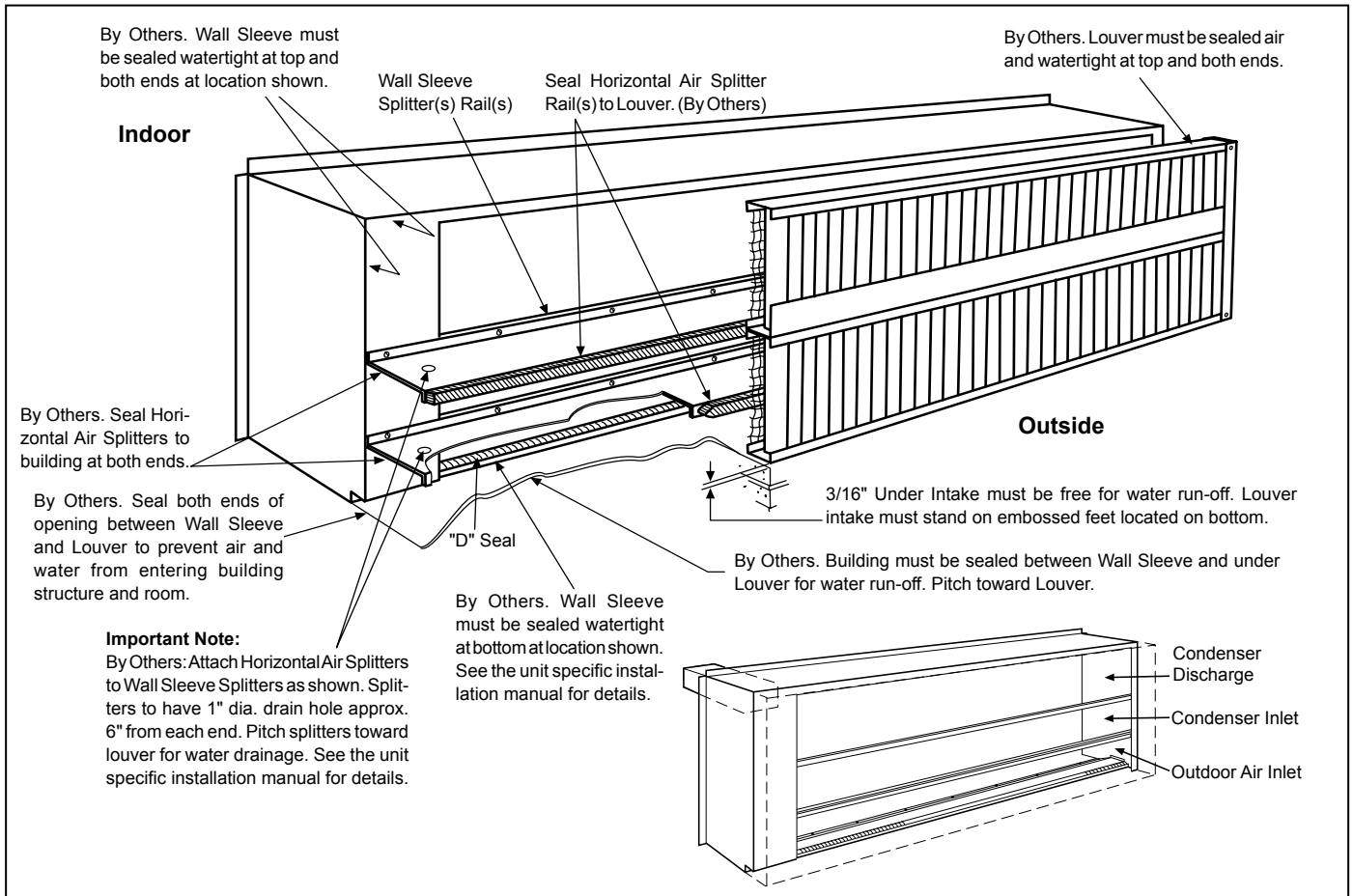

Figure 53: Sealing Full Projection Wall Sleeve and Horizontal Air Splitters

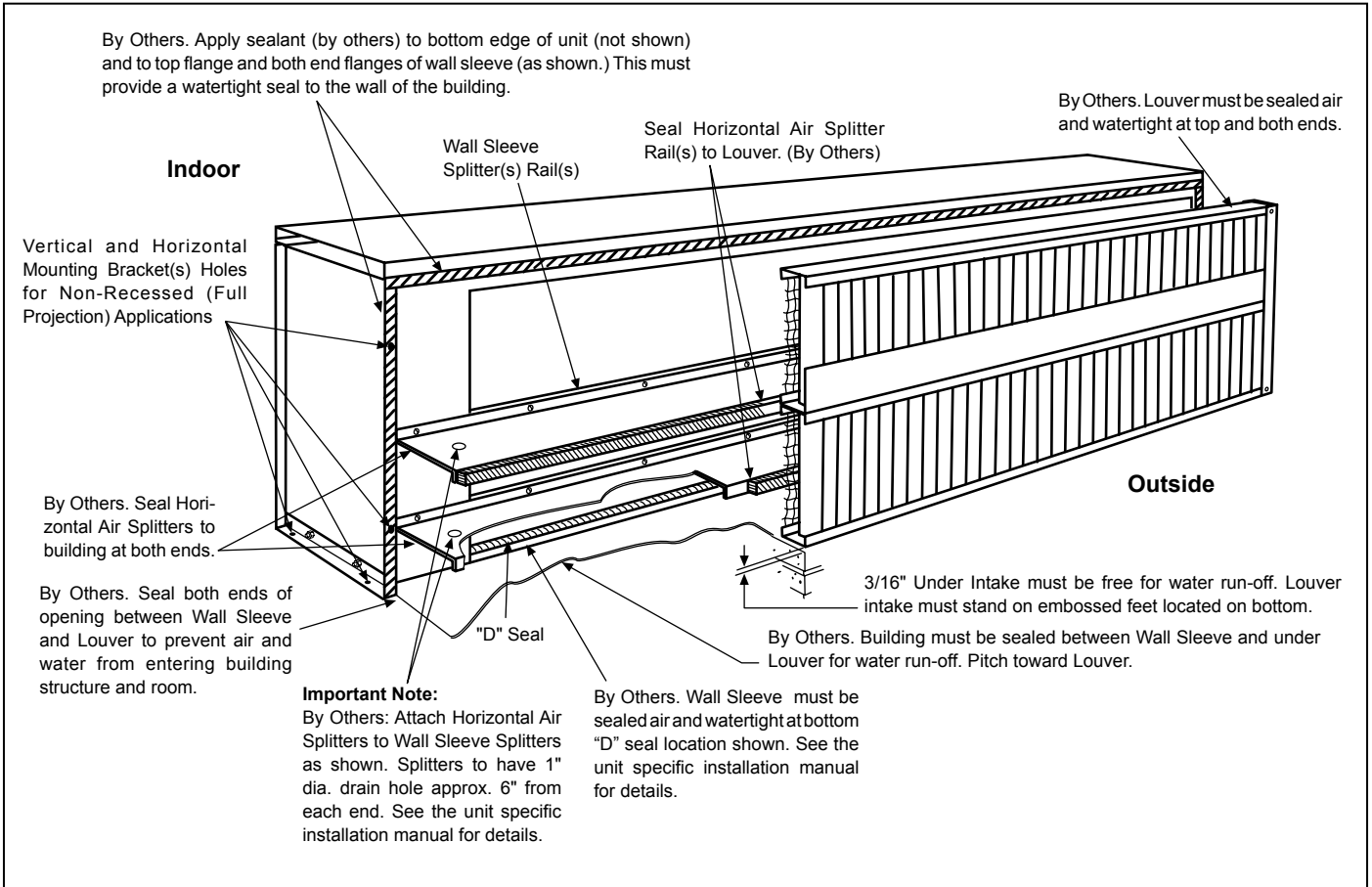

Figure 54: Recessed Wall Sleeve - Direct Sealing Wall Sleeve to Louver

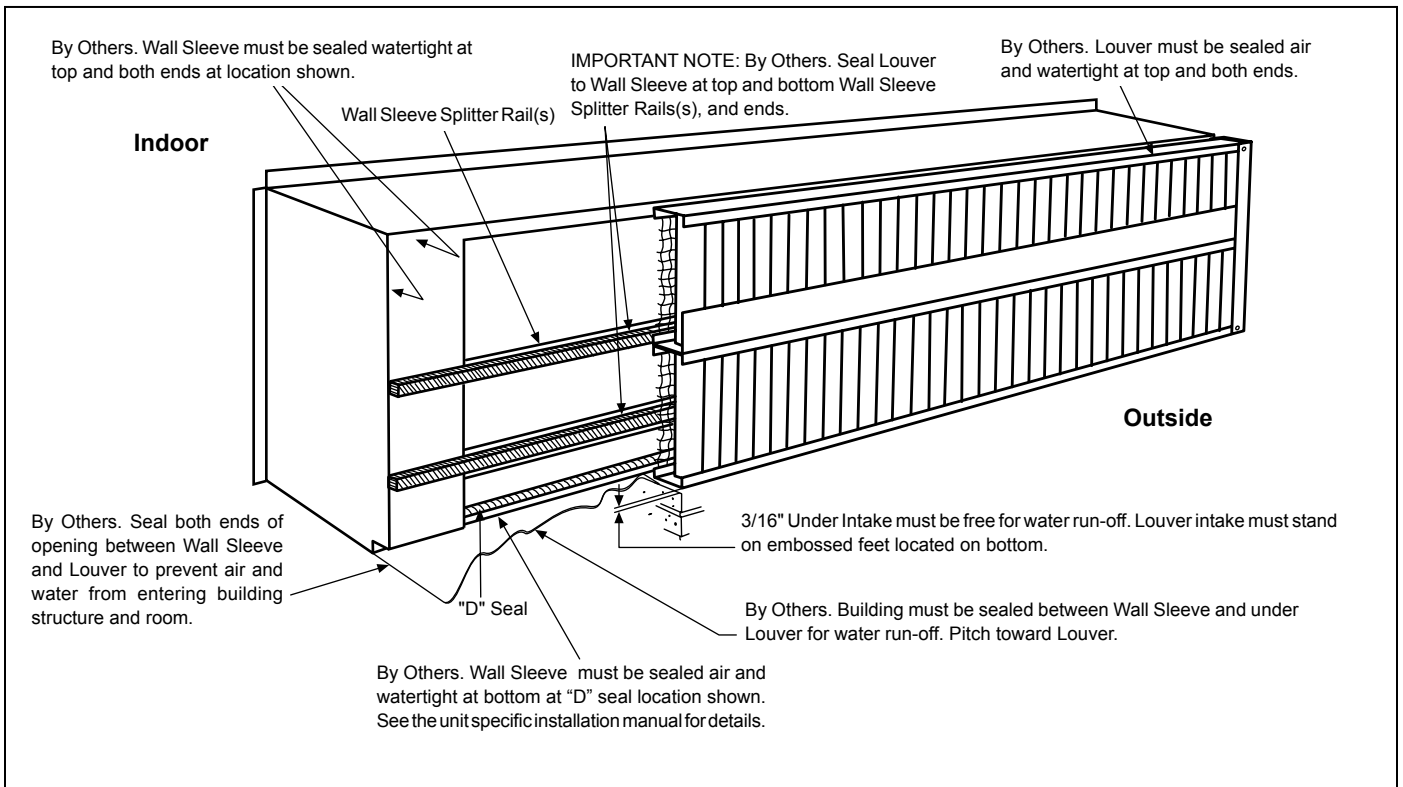

Figure 55: Sealing Full Projection Wall Sleeve to Louver Intake Without Horizontal Air Splitters

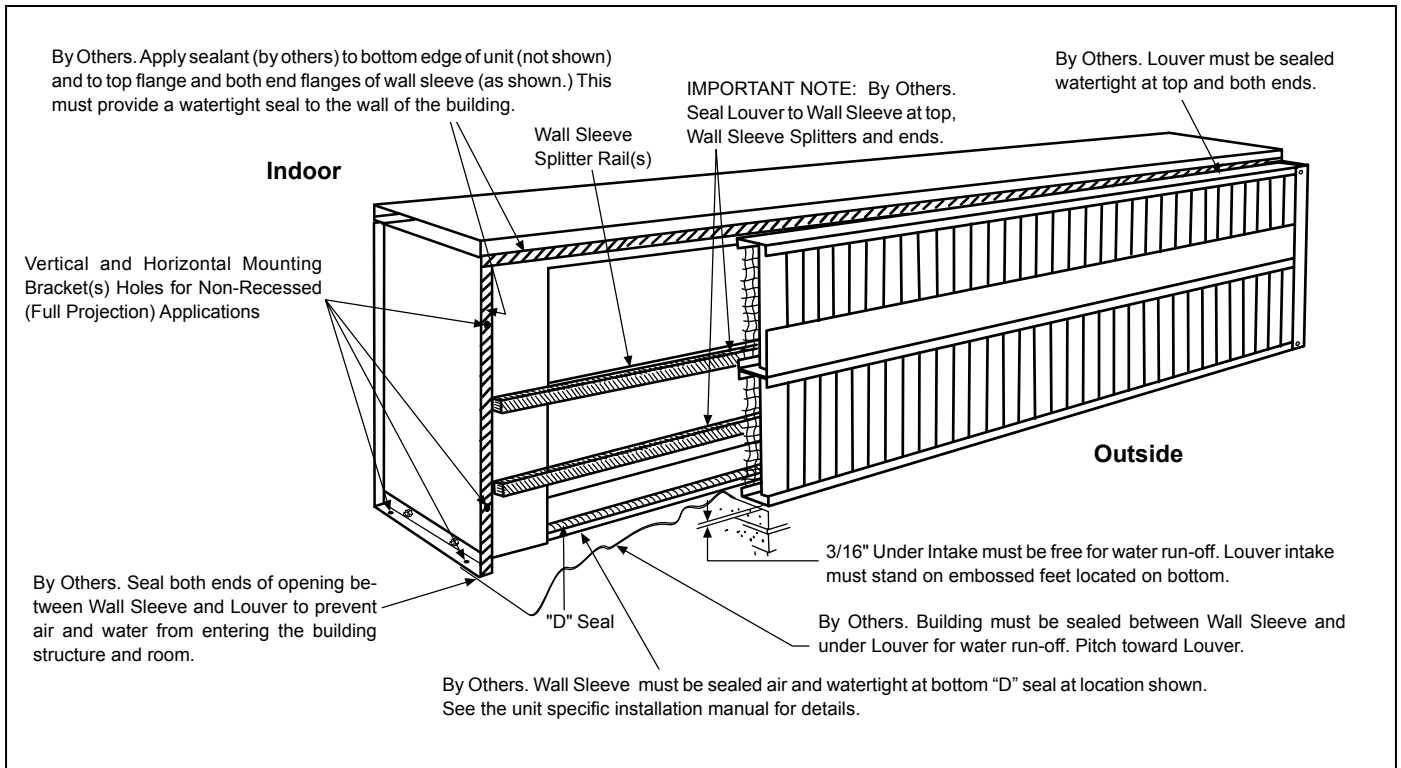
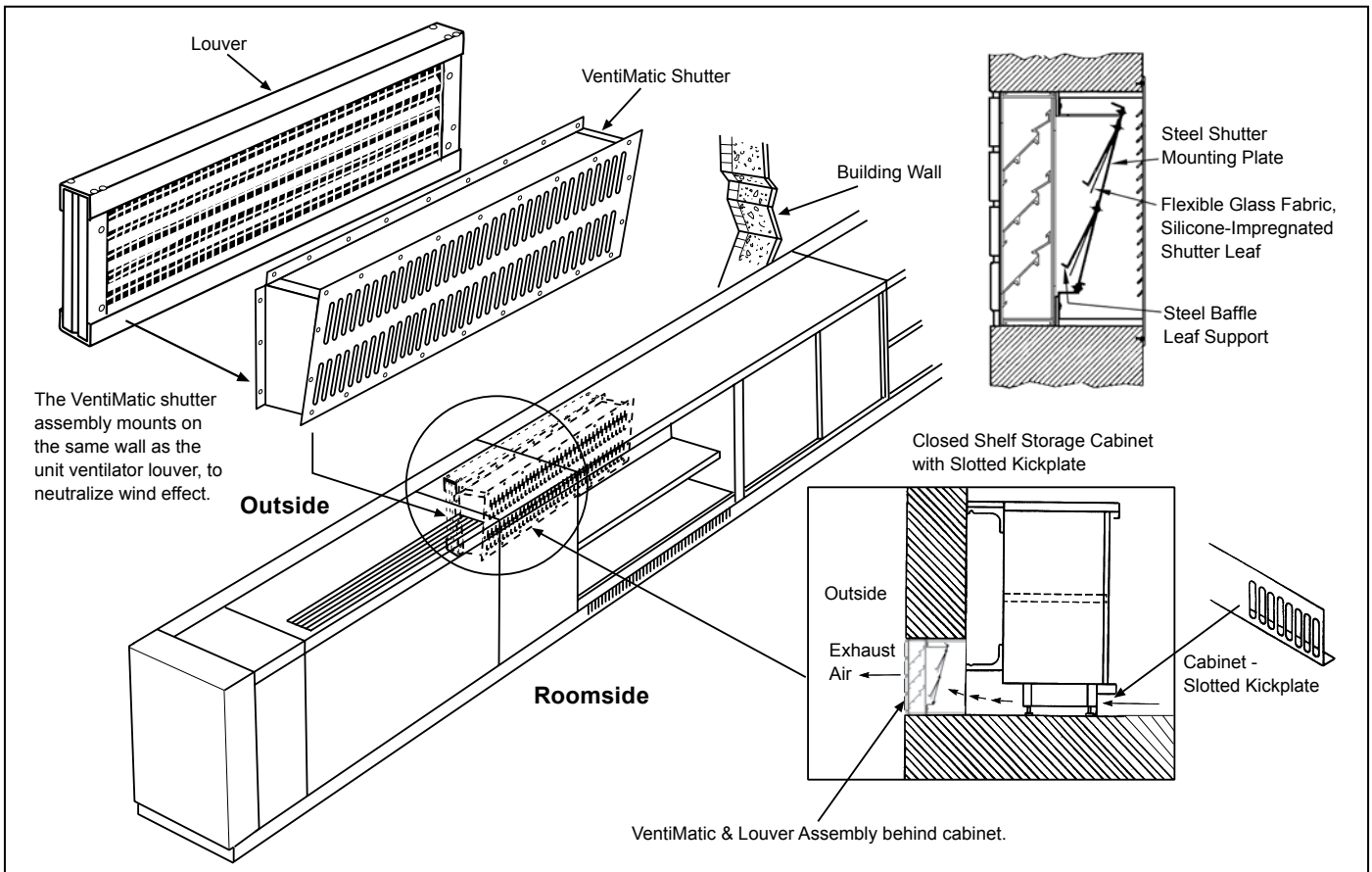

Figure 56: VentiMatic Shutter Installation



Model AEQ Air Source Heat Pump Self-Contained Unit Ventilator

General

Furnish and install where shown on plans, a complete self-contained, air cooled, heating and cooling unit ventilator. This unit shall meet capacities, airflow and configuration as shown on unit schedule.

Each standard unit must be listed by Underwriters Laboratories Inc. (U.L.) as complying with all safety standards.

The units shall ship fully assembled with the exception of the end panels which shall be packaged separately to allow easy access for piping and electrical rough-in. (Option: Wall sleeves shall be shipped in advance of unit for rough-in.)

Unit Construction

All internal sheet metal parts subject to corrosion must be made of galvanized steel. The entire frame must be welded construction to provide strength and rigidity. Frames assembled with sheet metal fasteners are not acceptable. Blow-thru design is not acceptable.

Cabinets

Exterior cabinet panels shall be constructed of heavy-gauge steel and every exposed corner must be welded and ground smooth for appearance and durability. All surfaces shall be cleaned and phosphatized, then painted with an oven baked powder paint. Top surface shall be Charcoal Bronze textured powder paint to resist scratching and hide fingerprints. Front access panels and top access door shall be supplied with tamper resistant fasteners.

Removable discharge grille shall be constructed of continuous, round edged, steel bars to provide a 10-degree vertical deflection.

Adjustable side deflection vanes shall be provided beneath the discharge grille to give optimal lateral air distribution. (Option: A 1/4" (6mm) mesh screen shall be provided beneath the discharge grille to protect against objects being dropped through the discharge grille.)

Room Air Fans and Motor

The motor and fan assembly shall be low speed design and shall be double inlet, forward curved centrifugal type with maximum fan speed of 1100 rpm. Fan wheels shall be constructed of dark, high density, injection molded polypropylene having high impact strength, chemical resistance and thermal stability. Assembly shall be direct drive type and shall be statically and dynamically balanced. Motor shall be permanent split capacitor (PSC) plug-in type (unit sizes 024, 036, 044), located out of the airstream and have an internal thermal overload device (auto-reset). Unit size 054 shall have an Electronically Commutated (EC) type. Fan speeds shall be controlled by High-Med-Low-Off switch. Fan/coil arrangement shall be draw-thru design for uniform coil face velocity and discharge air temperature. Fan motors and controls shall have each hot line protected by factory installed cartridge type fuse(s)

All components of the fan/motor assembly shall be removable from the front of the unit. The motor and fan shaft shall have sleeve type bearings with precision tolerances. Motors shall have permanently lubricated bearings. Fan shaft may have sleeve type bearing that requires oiling no more than once annually. Units requiring oiling will have an oil cap accessed from the left-side end compartment (or on the middle of the fan shaft on size 44MBH and larger). Some units are built with permanently sealed bearings that do not require oiling. Check for oil cap to determine which bearing type is present.

Condenser Fans and Motors

The fan board and fan housings shall be constructed of galvanized steel. The fan motor and fan shaft shall have permanently lubricated ball bearings. Motor for size 024 shall be a Permanent Split Capacitor (PSC) plug-in type. Unit sizes 036, 044, and 054 shall be an Electronically Commutated (EC) type. Fan wheels shall be forward curved centrifugal type.

Outdoor/Room Air Dampers

Each unit shall be provided with separate room air and outdoor air dampers. The room air damper shall be constructed of aluminum and counterbalanced against back pressure. Outdoor air damper shall be two-piece, double wall construction with 1/2" (13mm) thick, 1.5 lbs. (.68 kg) density fiberglass insulation sandwiched between welded galvanized steel blades. Outdoor air damper shall have additional foam insulation on the exterior of the blades and end partitions. Dampers shall be fitted with blended mohair seals along all sealing edges. Damper bearings shall be made of nylon or other material which does not require lubrication.

Drain Pan

All units shall have a drain pan constructed of galvanized steel.

[Option: Drain pan shall be constructed of stainless steel.]

Refrigeration System

The refrigeration section shall be constructed of galvanized steel and shall include a factory sealed, factory piped assembly consisting of a hermetically sealed compressor, a condenser coil, condenser fan and motor, and an evaporator coil. The equipment manufacturer is to be fully responsible for the integrity of the refrigerant piping and the entire refrigeration circuit, including compressor. Condenser and evaporator coils shall be fully assembled and tested prior to shipment. The motor compressor unit shall be vibration isolated internally and externally and shall be connected in such a manner as to prevent transmission of vibration to other components within the section.

Single-phase only: Single-phase units shall have permanent split capacitor (PSC) compressor motor with compressor start relay.

Units with three-phase power: Shall utilize three-phase compressors for balanced electrical compressor loads.

The condenser coil shall be constructed of copper tubes mechanically expanded to embossed aluminum plate fins. The unit shall be so designed as to allow access to the entering side of the condenser coil for cleaning without opening the sealed refrigeration circuit. The evaporator coil shall be constructed of copper tubing having embossed aluminum plate fins mechanically bonded thereto and shall be positioned above a galvanized steel drain pan.

Refrigerant shall be metered by a thermostatic expansion valve in lieu of capillary tubing to achieve evaporator performance and to protect the compressor from floodback of liquid refrigerant. The refrigerant section shall be adequately insulated to prevent "sweating."

The unit shall be furnished and wired with compressor thermal/current overload and high pressure cutout. Gauge ports shall be provided to allow reading of refrigerant pressures at the suction and discharge of the compressor. Compressor shall be equipped with internal pressure relief valve to protect against excessive pressure buildup.

(Optional) Electric Coils

Heating elements shall be of the open wire type. Electric heat shall be controlled in [three] stages. A capillary type high limit thermostat shall be provided to disconnect the heating elements through backup contactors if an overheat condition is detected. A front panel interlock switch shall be furnished to de-energize the electric resistance heating element when center front panel is opened.

Filter

Filter shall be one-piece type. Throwaway filter shall be factory furnished initially installed in the unit.

[Option: Furnish _____ extra set(s) of throw-away filters.]

[Option: Furnish one set of wire mesh permanent filters as final filter.]

[Option: Furnish one set of renewable (metal frame with glass fiber media) filters as final filter.]

[Option: Furnish _____ roll(s) of renewable filter media.]

Acoustical Features

The compressor shall be mounted on compressor isolators for external vibration isolation. Compressor enclosure panels shall be 16-gauge minimum. Complete interior of compressor compartment shall be lined with a multi-functional material that serves as a sound barrier, an absorber of sound and also must act as a decoupler to the compressor enclosure. This multi-functional material shall have a mylar coating on the face to act as a sound reflector and to increase the strength of the material. Damping material shall be textured foam type.

The exterior of the compressor compartment shall be coated with a high density damping material to eliminate impact noise and vibration. The right-hand front panel and the hinged top access door shall be coated with a high density material to minimize noise and vibration.

VentiMatic™ Shutter (Room Exhaust)

Where indicated, the unit ventilator manufacturer shall provide an “in-room” air relief VentiMatic shutter mounted on a separate wall intake louver to prevent excessive static pressure build-up in the room. The VentiMatic shutter shall be constructed of galvanized steel with shutter dampers of woven glass fabric impregnated with silicone rubber.

Temperature Controls

Each unit ventilator shall be furnished with a factory installed and wired, microprocessor based DDC Unit Ventilator Controller (UVC), by the manufacturer of the unit ventilator, which is pre-programmed, factory pretested prior to shipment and capable of complete, standalone unit control, or incorporation into a building-wide network using on-board BACnet MS/TP or an optional LONWORKS plug-in communication module.

The UVC shall support up to 16 analog inputs, 8 binary inputs, 4 analog outputs, 2 PWM outputs, and 14 binary outputs.

Units that are capable of providing up to 100% outside air shall provide a microprocessor-based Direct Digital Control (DDC) that can monitor conditions and automatically adjust unit operations to maintain these requirements. This DDC control shall have the following tenant adjustments: (1) room temperature setpoint, (2) minimum percent outdoor air setting, and (3) unoccupied setpoint (offset).

Network System

1. The unit control system shall perform all unit control functions, unit diagnostics and safeties. The unit shall operate in the standalone or network capable mode of operation. Standalone units to have on-board BACnet MS/TP communication built in. Field furnished and installed controls shall not be allowed. When network capable, network communication module shall be factory installed, tested and able to communicate via plug-in communication module that connect directly to the UVC using:
 - a. BACnet Client-Server/Token Passing (MS/TP) allowing the UVC to inter-operate with systems that use the BACnet (MS/TP) protocol with a conformance level of 3 meeting the requirements of ANSI/ASHRAE 135- 2008 standard for BACnet systems.
 - b. LONMARK space comfort control that supports the LONMARK SCC profile number 8500-10 allowing LONWORKS network communication capability to the UVC.
2. Unit controls shall allow for monitoring and adjustment via Daikin ServiceTools using a PC with Windows® 7 or newer operating systems. When using this PC and software, the unit shall be capable of reacting to commands for changes in control sequence and set points.

Room Temperature Sensor

Unit-Mounted

All units shall come equipped with a factory mounted room temperature sensor located in a sampling chamber (front, center panel) where room air is continuously drawn through for fast response to temperature changes in the room. When using a remote wall-mounted temperature sensor the ability shall exist to simply disconnect the unit-mounted temperature sensor using the provided quick disconnect plug. The room temperature sensor and override switch shall (SELECT one):

- a. be unit-mounted.
- b. be an optional wall-mounted temperature sensor, with integral tenant override capability

Sensor with Tenant Override and Setpoint Adjustment

Wall-Mounted

A sensor with integral tenant override and status LED shall be furnished with the unit ventilators. This sensor shall also contain a manually adjustable temperature setting allowing the controller setpoint to be increased or decreased by 5°F (2.8°C).

(Optional) Night Control

Night set-back/set-up control shall be provided by (SELECT one):

- a. A factory mounted and wired digital time clock (optional for standalone operation) which shall cycle the unit ventilator through occupied and unoccupied modes in accordance with one of twenty (20) user programmed time schedules.
- b. A remote mounted time clock as described in the temperature control specification and provided by the automatic temperature controls contractor. The unit in standalone mode shall have a single set of dry-contacts to signal unoccupied or occupied mode.
- c. The network DDC control system.

Wall Sleeve

The galvanized steel, one-piece wall sleeve shall be set in a wall opening and butted up directly against the intake louver. Where it is not possible to butt the wall sleeve against the wall intake louver, the contractor shall fabricate and install horizontal air splitters between the louver and wall sleeve to provide an airtight separation between condenser discharge and return air. The wall sleeve is to be permanently fastened in place and shall be suitably sealed, caulked or grouted by the contractor around the entire perimeter to prevent air leakage.

The wall sleeve shall be fitted with an electrical junction box containing a main "on-off" switch. All field wiring connections shall be made in this wall sleeve junction box.

(It shall be the installing contractor's responsibility to make the final load side power wiring connections between the wall sleeve junction box and the unit terminal block (including the wiring going to the electric heating elements. The wall sleeve shall be cartoned separately and shipped to the jobsite preceding the unit ventilator. Junction box shall ship separately for field installation.)

Wall Intake Louver

The louver shall be supplied by the unit manufacturer and shall be of heavy-gauge (unpainted, painted, or clear anodized) 6063-T5 aluminum construction. The louver shall be of the vertical blade type and shall be divided in half horizontally across the louver to prevent condenser air recirculation. A diamond pattern mesh bird screen shall be provided on the backside of the wall intake louver. All louvers shall be 28" (711mm) high by 2-1/2" (57mm) thick and suitable for both masonry and panel wall construction. The frame of the louver shall have weep holes along the bottom. Lintels shall be provided by the contractor above the louver opening.

Optional: Heavy-duty lattice grille horizontal and vertical lines shall "line up" with the louver blades to present an aesthetic appearance. Grille shall be fabricated from mill finish aluminum.

Agency Listing

Unit ventilators shall be listed by Underwriters Laboratories Inc. (U.L.) for the United States and Canada. Motors shall conform to the latest applicable requirements of NEMA, IEEE, ANSI, and NEC standards



Daikin Applied Training and Development

Now that you have made an investment in modern, efficient Daikin equipment, its care should be a high priority. For training information on all Daikin HVAC products, please visit us at www.DaikinApplied.com and click on Training, or call 540-248-9646 and ask for the Training Department.

Warranty

All Daikin equipment is sold pursuant to its standard terms and conditions of sale, including Limited Product Warranty. Consult your local Daikin Applied representative for warranty details. Refer to Form 933-430285Y. To find your local Daikin Applied representative, go to www.DaikinApplied.com.

Aftermarket Services

To find your local parts office, visit www.DaikinApplied.com or call 800-37PARTS (800-377-2787). To find your local service office, visit www.DaikinApplied.com or call 800-432-1342.

This document contains the most current product information as of this printing. For the most up-to-date product information, please go to www.DaikinApplied.com.

Products manufactured in an ISO Certified Facility.