



**Catalog 1620-8**

## **Daikin Classroom Unit Ventilators**

**Model AZQ, AZR, AZU Self-Contained Floor Units  
Size 024 (2 Ton) to 054 (4.5 Ton)**

**MicroTech® Control ("J" Vintage)**



**Model AZ**

<b>Introduction</b> . . . . .	<b>3</b>	Size 036 (1250 SCFM) – 2nd Stage High Fan . . . . .	52
Daikin Classroom Unit Ventilators . . . . .	3	Size 036 (1000 SCFM) – 1st Stage Medium Fan . . . . .	53
AHRI Performance Data – AZ . . . . .	4	Size 036 (800 SCFM) – 1st Stage Low Fan . . . . .	54
<b>Features &amp; Benefits</b> . . . . .	<b>5</b>	Size 044 (1500 SCFM) – 2nd Stage High Fan . . . . .	55
The Model AZ Floor Unit . . . . .	5	Size 044 (1050 SCFM) – 1st Stage Medium Fan . . . . .	56
The Right Amount of Fresh Air and Cooling . . . . .	7	Size 044 (850 SCFM) – 1st Stage Low Fan . . . . .	57
Precise Temperature and Dehumidification Control . . . . .	8	Size 054 (1500 SCFM) – 2nd Stage High Fan . . . . .	58
Draw-Thru Design For Even Discharge Temperatures . . . . .	8	Size 054 (1050 SCFM) – 1st Stage Medium Fan . . . . .	59
Low Installation Costs . . . . .	9	Size 054 (850 SCFM) – 1st Stage Low Fan . . . . .	60
Low Operating Costs . . . . .	9	<b>Electrical Data</b> . . . . .	<b>61</b>
Easy To Maintain . . . . .	10	AZU & AZQ – Size 024 . . . . .	61
Built To Last . . . . .	12	AZR – Size 024 . . . . .	61
<b>General Data</b> . . . . .	<b>15</b>	AZU & AZQ – Size 036 . . . . .	62
Nomenclature . . . . .	15	AZR – Size 036 . . . . .	62
Model Types . . . . .	16	AZU & AZQ – Size 044 . . . . .	63
MicroTech® Controls . . . . .	17	AZR – Size 044 . . . . .	63
<b>Accessories</b> . . . . .	<b>19</b>	AZU & AZQ – Size 054 . . . . .	64
End Panels . . . . .	19	AZR – Size 054 . . . . .	64
Wall Sleeves . . . . .	20	<b>Wiring Diagrams</b> . . . . .	<b>65</b>
Wall Louvers & Grilles . . . . .	21	Typical MicroTech Wiring Diagram – 208V / 60Hz / 1Ph . . . . .	65
Wall Intake Louvers & Grilles . . . . .	22	Typical MicroTech Wiring Diagram – Service & Disconnect 208V / 60Hz / 1Ph . . . . .	66
VentiMatic Shutter Room Exhaust Ventilation . . . . .	23	Typical Wall Sensors Diagram . . . . .	67
VentiMatic Shutter Assembly . . . . .	24	Power & Control Field Wiring . . . . .	67
Physical Data . . . . .	25	ElectroMechanical Control . . . . .	69
<b>Details &amp; Dimensions</b> . . . . .	<b>26</b>	<b>MicroTech Controls</b> . . . . .	<b>71</b>
Model AZ Self-Contained – Size 024 . . . . .	26	Control Modes and Functions . . . . .	71
Model AZ Self-Contained – Size 036 . . . . .	27	External Input Functions . . . . .	72
Model AZ Self-Contained – Sizes 044, 054 . . . . .	28	External Output Functions . . . . .	72
AZU and AZQ Hot Water Coil Connection Locations . . . . .	29	Advanced Control Options . . . . .	73
AZR Hot Water Coil Connection Locations . . . . .	30	System Components . . . . .	74
AZU, AZR, and AZQ Steam Coil Connection Locations . . . . .	31	MicroTech Sensor and Component Locations . . . . .	76
End Panels . . . . .	32	Room Temperature Sensors used with MicroTech Unit Controls . . . . .	77
<b>Valves</b> . . . . .	<b>33</b>	Actuators . . . . .	78
Face & Bypass End of Cycle Valves . . . . .	33	<b>Application Considerations</b> . . . . .	<b>80</b>
Modulating Valves . . . . .	34	Why Classrooms Overheat . . . . .	80
2-Way Modulating Valve (Steam) - 1/2" . . . . .	36	Meeting IAQ Requirements . . . . .	82
2-Way Modulating Valve (Steam) - 3/4" . . . . .	38	Face & Bypass Temperature Control . . . . .	84
3-Way Modulating Hot Water Valve . . . . .	40	Modulating Valve Temperature Control . . . . .	86
<b>Performance &amp; Selection</b> . . . . .	<b>42</b>	Coil Selection . . . . .	87
Quick Selection Procedure . . . . .	42	ASHRAE Cycle II . . . . .	88
Hot Water Heating Selection . . . . .	47	Unit Installation . . . . .	90
Steam Heating Selection . . . . .	48	Wall Louvers . . . . .	91
Electric Heating Selection . . . . .	48	Lintels . . . . .	91
<b>Capacity Data</b> . . . . .	<b>49</b>	Wall Sleeve Arrangements . . . . .	93
Size 024 (1000 SCFM) – 2nd Stage High Fan . . . . .	49	Valve Selection . . . . .	96
Size 024 (750 SCFM) – 1st Stage Medium Fan . . . . .	50	<b>Guide Specifications</b> . . . . .	<b>100</b>
Size 024 (650 SCFM) – 1st Stage Low Fan . . . . .	51		

## Daikin Classroom Unit Ventilators



For nearly a century schools have relied on unit ventilators to keep classrooms comfortable.

Students learn more readily in a quiet, well-ventilated environment. That is why Herman Nelson invented the unit ventilator in 1917. Daikin Applied continues to set the industry standard for performance, features and quality. Today Daikin remains committed to continuing the Herman Nelson-AAF-McQuay legacy as the industry leader and meeting the changing requirements of schools with the highest quality unit ventilator products available.

We realize that keeping expenditures down is a high priority for school administrators and school boards.

Daikin unit ventilators are inexpensive to install and operate, and they are designed and built to provide years of trouble-free service.

### Quiet Operation

Daikin unit ventilators are engineered and manufactured to deliver quiet, continuous comfort. We developed our GentleFlo™ air moving system to minimize operating sound levels—even as demands for more fresh air require units to operate longer and work harder.

#### *The Right Amount of Fresh Air and Cooling*

Daikin unit ventilators deliver required amounts of fresh air to meet ventilation requirements, and added cooling capacity to maintain consistent comfort for students and teachers. Our Economizer Operation, Demand Control Ventilation (DCV) and Part Load, Variable Air options allow you to closely match comfort requirements and reduce operating costs.

#### *Precise Temperature and Dehumidification Control*

Daikin unit ventilators feature precise temperature and dehumidification control to keep students and teachers comfortable while making maximum use of “free” outdoor-air cooling to reduce operating costs. They utilize a draw-thru air design that contributes to even heat transfer and uniform discharge air temperatures into the classroom. Coupled with our MicroTech® active dehumidification control strategy, they provide precise control of temperature and humidity levels.

### Low Installation Costs

New construction installations are easily accomplished with Daikin unit ventilators because they avoid the added cost and space required for expensive ductwork. Retrofit installations are also economical because new units fit the same space occupied by existing ones. Factory installed MicroTech® controls with Protocol Selectability™ provide easy, low cost integration into the building automation system of your choice.

### Low Operating Costs

Daikin unit ventilators minimize energy usage by utilizing a two-stage compressor and multi-speed fan to better match changing room loads. They take maximum advantage of “free” cooling opportunities to reduce operating costs. During unoccupied periods and at night, units operate sparingly to conserve energy.

### Easy To Maintain, Modular Design

Daikin Unit Ventilators are designed to provide easy access for maintenance and service personnel to all serviceable components. Most tasks are easily handled by a single person.

### Built To Last

Our proven institutional design can withstand the rigors of the classroom environment. It features an extra-sturdy chassis and double-wall damper on the inside; scuff-resistant finishes and tamper prevention features on the outside. In fact, many units installed over 30 years ago continue to provide quiet, reliable classroom comfort.

### MicroTech® Control For Superior Performance, Easy Integration

Daikin unit ventilators can be equipped with MicroTech unit controllers for superior performance. Factory integrated and tested controller, sensor, actuator and unit options promote quick, reliable start-up and minimize costly field commissioning. Our Protocol Selectability feature provides easy, low-cost integration into most building automation systems. Daikin's MicroTech UV controller has on-board BACnet communications, with optional LoNTALK®, allowing users to communicate control and monitoring information to your BAS, without the need for costly gateways.

## AHRI Performance Data – AZ

Unit Size	Compressor Capacity	Fan Speed	Nominal Airflow	Cooling Performance	
				Total Capacity	Efficiency
			CFM	Btuh	EER
024	Full	High	1000	20700	9.7
036	Full	High	1250	38100	10.6
044	Full	High	1500	44900	10.4
054	Full	High	1500	53500	10.4

**Notes:** Full load cooling conditions: Indoor 80°F db/67°F wb-Outdoor; 95°F db/75°F wb and high-speed fan.



*Since 1917*



*... and setting the standard today*

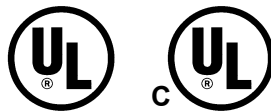

## The Model AZ Floor Unit

Our Model AZ is a vertical, floor-standing unit that utilizes refrigerant for cooling, and hot water, steam or electric heat for heating. The Model AZ also can be supplied as a cooling/ventilating only unit.

The Model AZ is just right for new construction and for retrofit applications. Older buildings with baseboard radiant heat or other hydronic heating systems can be easily adapted to work efficiently with Model AZ units.

The major features of this model are shown below and described in more detail on the following pages.

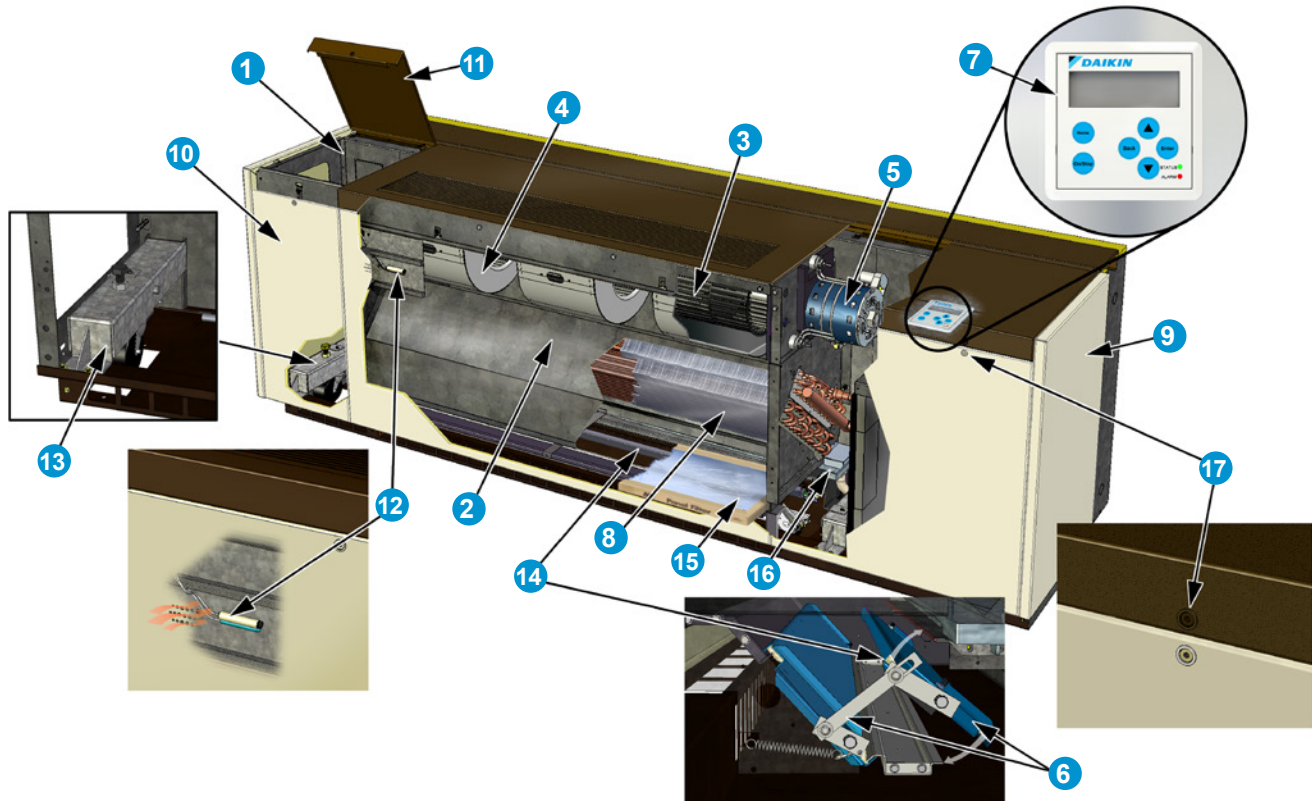

- |   |  |   |
|---|--|---|
| <p><b>1 Welded one-piece chassis</b></p> <ul style="list-style-type: none"> <li>• offers superior strength, durability, and vibration reduction</li> </ul> <p><b>2 Unique draw-thru design</b></p> <ul style="list-style-type: none"> <li>• provides uniform air distribution across the coil for even discharge air temperatures</li> </ul> <p><b>3 Quiet, aerodynamic fans</b></p> <ul style="list-style-type: none"> <li>• utilize GentleFlo technology for exceptionally quiet unit operation</li> </ul> <p><b>4 Modular fan section</b></p> <ul style="list-style-type: none"> <li>• improves balance, alignment and simplifies maintenance</li> </ul> <p><b>5 Fan motor</b></p> <ul style="list-style-type: none"> <li>• located out of air stream and away from heating coil reduces heat exposure to prolong life</li> </ul> <p><b>6 Outside air/return air dampers &amp; linkage</b></p> <ul style="list-style-type: none"> <li>• provides superior mixture of outdoor air and room air for precise temperature control</li> </ul> | <p><b>7 MicroTech controls (optional)</b></p> <ul style="list-style-type: none"> <li>• provide superior comfort control and easy integration into the building automation system of your choice</li> </ul> <p><b>8 Advanced heat transfer coil</b></p> <ul style="list-style-type: none"> <li>• design provides extra capacity</li> </ul> <p><b>9 Sturdy cabinet construction</b></p> <ul style="list-style-type: none"> <li>• includes hidden reinforcement, a non-glare textured surface, and a tough, scuff- and mar-resistant finish to stand up to the abuses of a classroom environment</li> </ul> <p><b>10 Sectionalized front access panels</b></p> <ul style="list-style-type: none"> <li>• provide easy access to unit interior. Panels are easily removed by a single person. Front side panels can be removed while unit is running</li> </ul> | <p><b>11 Two hinged top access doors</b></p> <ul style="list-style-type: none"> <li>• provide easy access to the motor, electrical, and refrigeration components</li> </ul> <p><b>12 Sampling chamber for unit-mounted sensor</b></p> <ul style="list-style-type: none"> <li>• provides accurate sensing of room temperature</li> </ul> <p><b>13 Optional adjustable caster</b></p> <ul style="list-style-type: none"> <li>• (Left and right ends)</li> </ul> <p><b>14 Insulated double-wall outdoor air damper</b></p> <ul style="list-style-type: none"> <li>• seals tightly without twisting</li> </ul> <p><b>15 Full-length air filter</b></p> <ul style="list-style-type: none"> <li>• is efficient and easy to replace. All air delivered to classroom is filtered.</li> </ul> <p><b>16 Galvanized steel drain pan or optional stainless steel</b></p> <p><b>17 Tamper resistant fasteners on access panels</b></p> |
|---|--|---|

## GentleFlo Delivery

Daikin unit ventilators are engineered and manufactured to deliver quiet, continuous comfort. We developed our GentleFlo™ air moving system to minimize operating sound levels – even as demands for more fresh air require units to operate longer and work harder.

GentleFlo features include:

- Fan wheels are large, wide and rotate at a low speed to reduce fan sound levels. They are impact-resistant and carefully balanced to provide consistent performance.
- Offset, aerodynamic fan wheel blades move air efficiently (Figure 1).
- Precision tolerances help reduce flow and pressure turbulence, resulting in lower sound levels.

Figure 1: GentleFlo Fan Technology

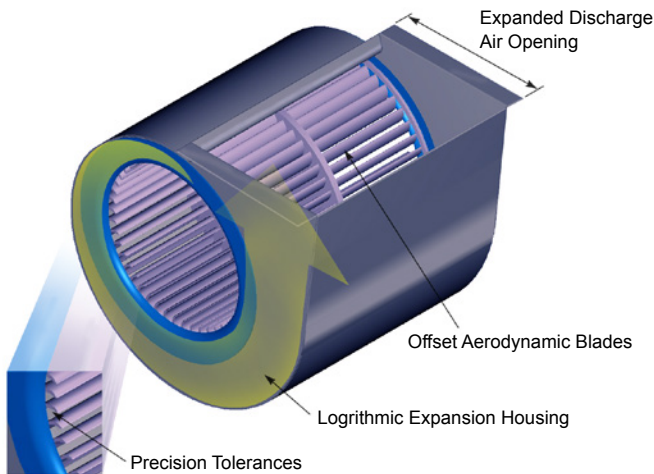

- Fan housings incorporate the latest logarithmic-expansion technology for smoother, quieter air flow (Figure 2).
- A large, expanded discharge opening minimizes air resistance, further lowering sound levels.
- Modular fan construction contributes to equal outlet velocities and promotes quiet operation.
- Fan shafts are of ground and polished steel to minimize deflections and provide consistent, long-term operation.
- Fan assemblies are balanced before unit assembly, then tested after assembly (and rebalanced if necessary) to provide stable, quiet operation.

Figure 2: GentleFlo Reduces Turbulence

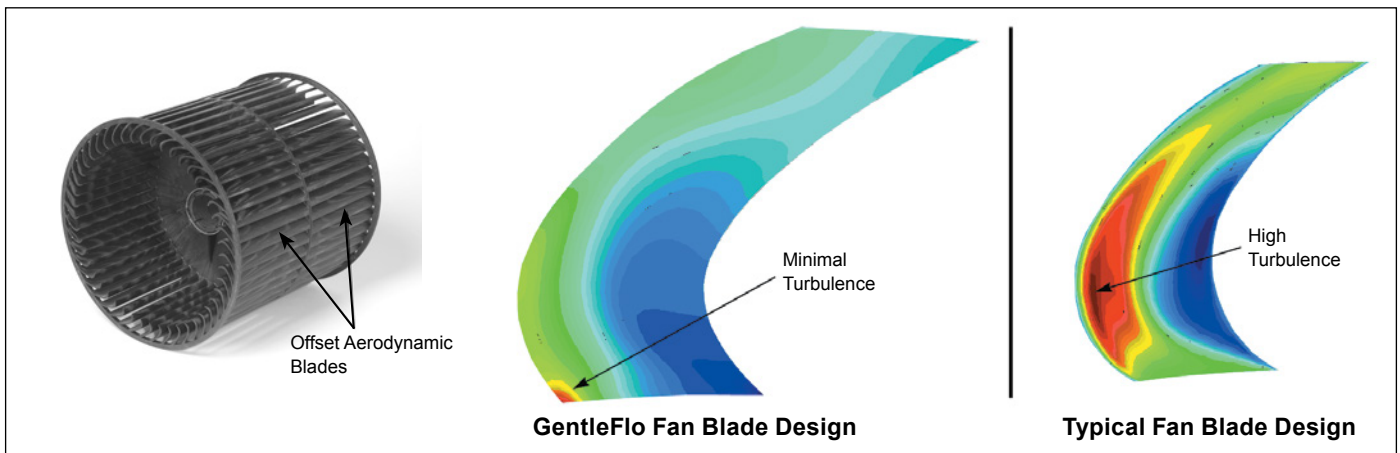

## The Right Amount of Fresh Air and Cooling

Daikin unit ventilators deliver required amounts of fresh air to meet ventilation requirements and added cooling capacity to maintain consistent comfort for students and teachers. Our Economizer Operation, Demand Control Ventilation (DCV) and Part Load, Variable Air options allow you to match classroom comfort requirements even more closely, and reduce operating costs.

This means that you can be confident that your school is meeting ventilation standards for Indoor Air Quality and that your students are receiving adequate air to be attentive to instruction. At the same time, you are saving money in early morning hours, between classes or after hours when classrooms are heated and cooled but not always fully occupied.

### Economizer Operation

It is well recognized that cooling, not heating, is the main thermal challenge in school classrooms. The typical classroom is cooled by outdoor air over half the time, even in cold climates. It is therefore essential that unit ventilators efficiently deliver outdoor air when classroom conditions call for “free” or economizer cooling.

With Daikin unit ventilators, you can have outdoor air whenever it is needed. Economizer operation is facilitated by the outdoor air damper, which automatically adjusts the above-minimum outside air position to provide free cooling when the outdoor air temperature is appropriate (Figure 3). On units equipped with MicroTech controls, three levels of economizer control are available.

**Figure 3: Full Economizer Mode**

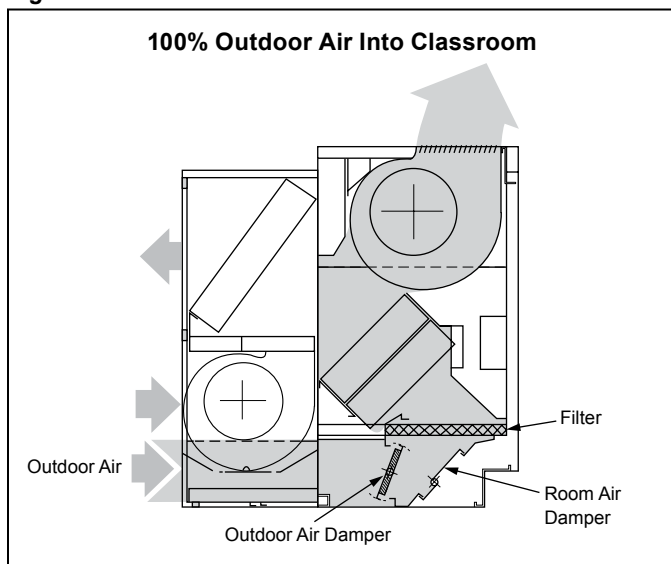

### Part-Load Variable Air Control

Part Load Variable Air control can be used to automatically adjust the unit ventilator fan speed based upon the room load and the room temperature. This MicroTech control option provides higher latent cooling capabilities and quieter operation during non-peak load periods by basing indoor fan speed upon room load.

Lower fan speeds in conjunction with our GentleFlo fan technology contributes to a very quiet classroom environment.

Room-temperature PI control loops determine the speed of the fan, which varies according to the room load. It also provides a built-in delay to prevent overshooting for better comfort control. The outdoor air damper’s minimum-air position is adjusted with the fan speed to bring in a constant amount of fresh air.

### Demand Control Ventilation

Daikin unit ventilators can be equipped to use input from a CO<sub>2</sub> controller to ventilate the space based on actual occupancy instead of a fixed design occupancy. This Demand Controlled Ventilation (DCV) system monitors the amount of CO<sub>2</sub> so enough fresh outdoor air is introduced to maintain good air quality. The system is designed to achieve a target ventilation rate (e.g., 15 CFM/person) based on actual occupancy.

By using DCV to monitor the actual occupancy pattern in a room, the system can allow code-specific levels of outdoor air to be delivered when needed. Unnecessary over-ventilation is avoided during periods of low or intermittent occupancy, leading to improved energy efficiencies and cost savings.

## Precise Temperature and Dehumidification Control

Daikin unit ventilators provide precise temperature and dehumidification control to keep students and teachers comfortable while making maximum use of “free” outdoor-air cooling to reduce operating costs. They utilize a draw-thru fan design that contributes to even heat transfer and provides uniform discharge air temperatures into the classroom. MicroTech control strategies and 2-stage compressor operation, provide precise control of temperature and humidity levels under both part-load and full-load conditions.

## Draw-Thru Design For Even Discharge Temperatures

The Daikin Draw-Thru design sets our unit ventilators apart from most competitive models. With this system, fans draw air through the entire heat transfer element (Figure 4) rather than blowing it through highly concentrated areas of the coil element. The result is more uniform discharge air temperatures into the classroom and more efficient unit ventilator operation.

Figure 4: Draw-Thru Design Provides Even Discharge Air

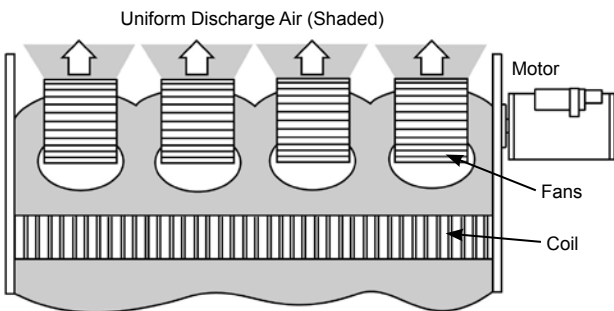
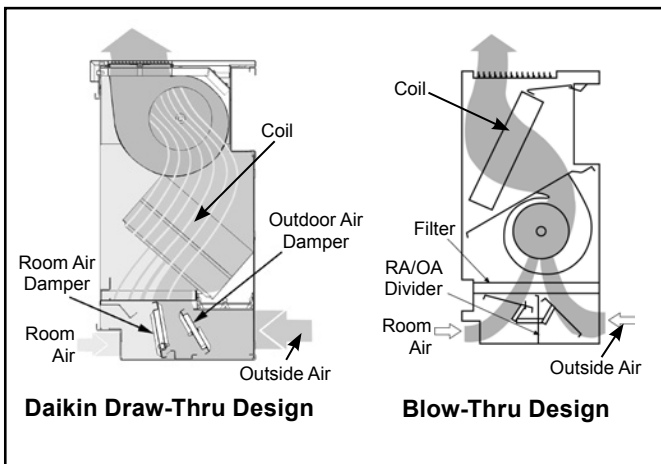

Figure 5: Draw-Thru Vs. Blow-Thru Design



## Active Dehumidification (Reheat)

In high-humidity applications where valve-controlled, reheat units are used, the Active Dehumidification Control (ADC) sequence should be considered. During excessive humidity conditions, a humidity sensor directs the unit to continue cooling past the room setpoint to remove excess moisture. Hydronic heat or electric heat is then used to reheat the discharge air to maintain acceptable room temperatures.

MicroTech controls minimize the amount of reheat needed to maintain relative humidity below a preset limit. Reheat is used only when required and in the most energy-efficient manner possible. See "Active Dehumidification Control (Reheat)" on page 74 for more information.

## Increased Coil Freeze Protection

Daikin units equipped with face and bypass damper control provide extra protection from coil freeze-up, because there is a constant flow of hot water through the coil, and water that is flowing typically does not freeze. Additionally, all Daikin Applied units feature a double-walled, insulated outdoor air damper with airtight mohair seals to prevent unwanted coil air from entering the unit.

Furthermore, a low-temperature freezestat is factory installed on all units with hydronic coils. Its serpentine capillary tube senses temperatures across the leaving air side of the coil, allowing the unit controller to react quickly to low-temperature conditions.

Figure 6: Freezestat

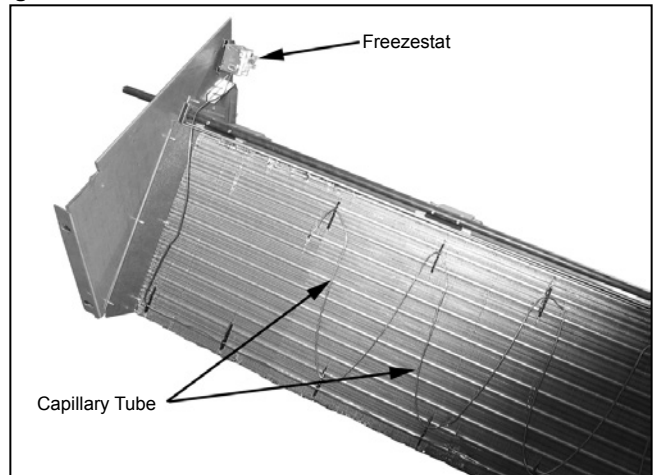



## Low Installation Costs

Daikin unit ventilators have many features that make them economical to purchase and to install in both new construction and retrofit applications. It is this attention to detail and understanding of school applications that make them the system of choice.

## Perfect For Both New & Retrofit Applications

New construction installations are easily accomplished with Daikin unit ventilators because they avoid the added cost and space required for expensive ductwork. Further savings can be realized because piping installations use less space than duct systems.

This is important in existing buildings and also in new construction where floor-to-floor heights can be reduced, saving on overall building costs.

Retrofit installations are economical because new units typically fit the same space occupied by existing ones, resulting in lower project cost and shorter project schedules.

## Controls Flexibility

Multiple control options—including MicroTech controls with our Protocol Selectability feature—provide easy, low cost integration of Daikin unit ventilators into the building automation system of your choice (See "[Communication Types](#)" on page 75).

MicroTech controls come with on-board BACnet MS/TP communications, with optional LON<sup>TALK</sup>, to communicate control and monitoring information to your BAS, without the need for costly gateways.

## Low Operating Costs

Schools consume more than 10% of the total energy expended in the United States for comfort heating and cooling of buildings. As energy costs increase, educators are placed in a difficult position: caught between rising costs, lower budgets and the requirements to raise educational standards.

Fortunately, the technology and the system exists for schools to take control of their energy expenditures while providing a comfortable environment for learning. And that system is the Daikin unit ventilator.

Consider these realities of school environments:

- Most heating energy in schools is expended to heat unoccupied spaces. Because lights, computers and students give off considerable heat, occupied spaces require little supplemental heat.
- The removal of heat is usually required in occupied classrooms, even when outside temperatures are moderately cold (i.e., 35 to 40°F).
- Then consider how Daikin unit ventilators, located in each classroom, take advantage of these realities to lower operating costs:
- They provide individual classroom control and comfort.
- They can be cycled on when the room is occupied and cycled off when it is not.
- They bring in fresh air from directly outside the classroom for high indoor air quality.
- During most of the school year, they use outdoor air to keep classrooms comfortable without the expense of mechanical cooling.

## MicroTech® Control Options Further Reduce Operating Costs

Many of the MicroTech control options available with Daikin unit ventilators can further reduce operating costs. For example:

- **Economizer Operation:** Economizer operation automatically adjusts the above-minimum outside air position to provide free cooling when the outdoor air temperature is appropriate.
- **Demand Control Ventilation:** By using CO<sub>2</sub> levels to monitor the actual occupancy pattern in a room, the system can allow code-specific levels of outdoor air to be delivered when needed without costly over-ventilation during periods of low or intermittent occupancy (Figure 7).

Figure 7: Energy Savings with Demand Control Ventilation

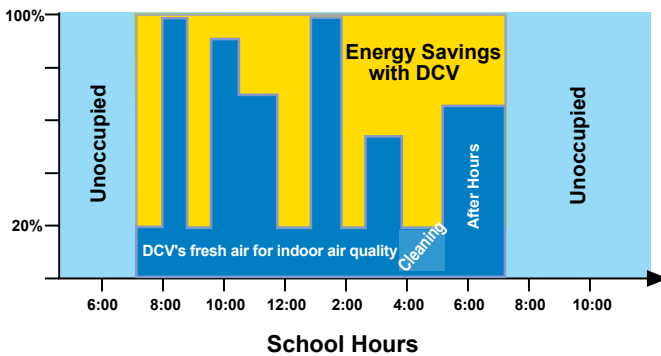

- **Occupancy Mode Operation:** Units can be programmed to operate only sparingly during unoccupied periods and at night to conserve energy.

## Two-Stage Compressor

Air conditioning units are usually sized for worse case conditions. During high load requirement the unit will operate in high fan speed and high compressor capacity. Most of the time there is not a full load on the compressor. Operation in lower load will be at medium or low fan speeds which will be at the lower displacement compressor stage. The two stage compressor will remain at low speed until more cooling is required. With the two-stage compressor, the unit will run on lower fan speeds most of the time improving comfort through better humidity control and quieter operation, while minimizing issues with over-sizing.

Other units utilizing single stage compressors operate at full compressor capacity all of the time regardless of fan speed.

## Easy To Maintain

Daikin Unit Ventilators are designed to provide easy access for maintenance and service personnel to all serviceable components. Most maintenance tasks are easily handled by a single person.

### Modular Fan Deck

The entire fan deck is easily removed as a single unit. This provides ready access to fan wheels, motors, bearings and other components for service, cleaning or repair.

The fan deck's rotating element has one large, self-aligning end bearing and a permanently lubricated motor bearing for smooth operation. On most sizes the location of the fan shaft bearing is at the end of the shaft (out of the air stream). This enables easy access for oiling on units built with an oilable end bearing (some units built with permanently sealed end bearings).

Figure 8: Long-Life Bearings



Permanently Lubricated Motor Bearing

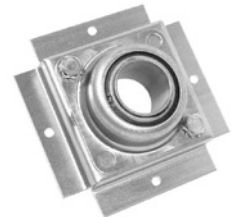

Self-Aligning, Oilable End Bearing

## Heavy-Duty Discharge Grille

The discharge grille on the top of the unit is made from extra-strength steel bar stock, promoting long life (Figure 9). It can be removed to facilitate cleaning of fans and fan housings. A built-in 10-degree angle provides proper air throw to blanket the room for proper air circulation and comfort.

Figure 9: Heavy-Duty Steel Discharge Grille

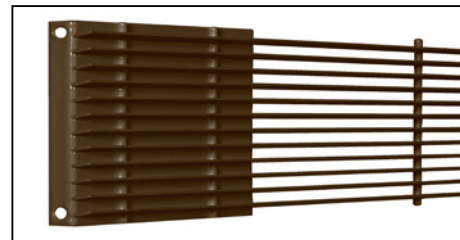

## Easy Motor Removal

Unlike with many competitive models, the motor in Daikin unit ventilators is separate from the fan assembly and is located out of the airstream at the end of the fan shaft—away from the hot coil—for easier maintenance and removal. Locating the motor away from the coil (Figure 10 on page 11) has the added benefit of extending motor life. Our direct-coupled motor and self-aligning motor mount facilitate motor change-out. The motor comes with a molex plug that fits all sizes and further simplifies removal.

**Figure 10: Modular Design**

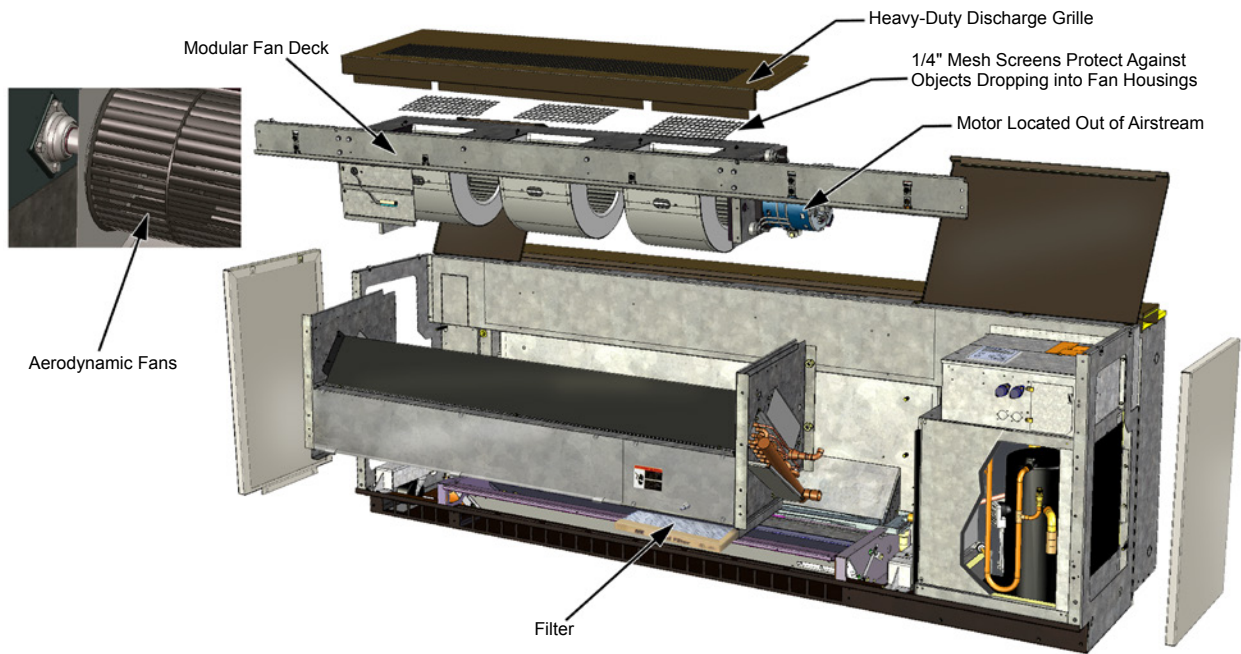

**Tamper-Resistant Fasteners**

Front panels and top access doors are held in place by tamper-resistant, positive-positioning fasteners. They are quickly removed or opened with the proper tool, but deter unauthorized access to the unit’s interior (See [Figure 12 on page 12](#)).

**Sectionalized Access Panels and Doors**

All units have three separate front panels and hinged top access doors, sized for convenient handling by a single person (See [Figure 12 on page 12](#)). The result is easy, targeted access to the component that needs servicing:

- Two end panels provide easy access to piping, temperature control components and the fan switch. Unlike units with full-length front panels, these can be removed without disturbing the normal operation of the unit.
- Hinged top access doors provide easy access into the end compartments to facilitate convenient servicing of the motor, electrical, and refrigeration components.
- Center front panel provides easy access to the filter and the fan shaft bearing on unit sizes 044 and 054.

**Filter**

Three filter types are offered:

- Units come standard with a single-use filter which is designed to be used once and discarded.
- Optional, permanent metal filters are available and can be removed for cleaning and reused numerous times.
- Renewable media filters, which consist of a heavy-duty, painted-metal structural frame and renewable media.

**Figure 11: Easy Access to Filter**

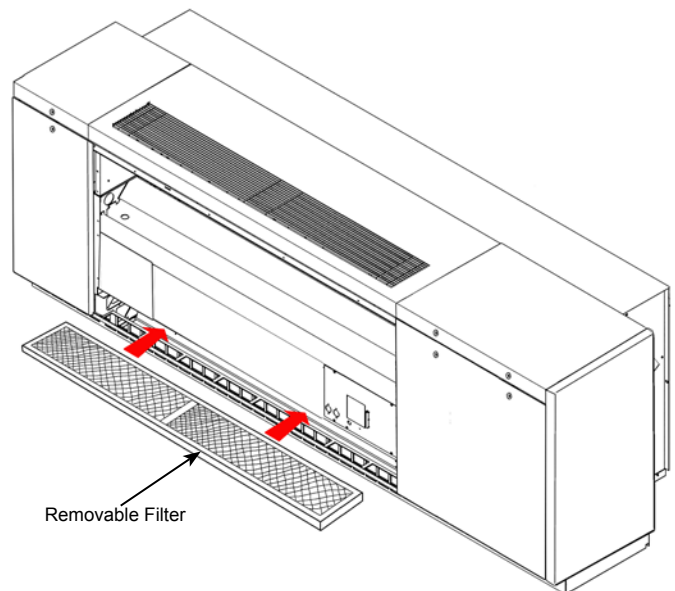
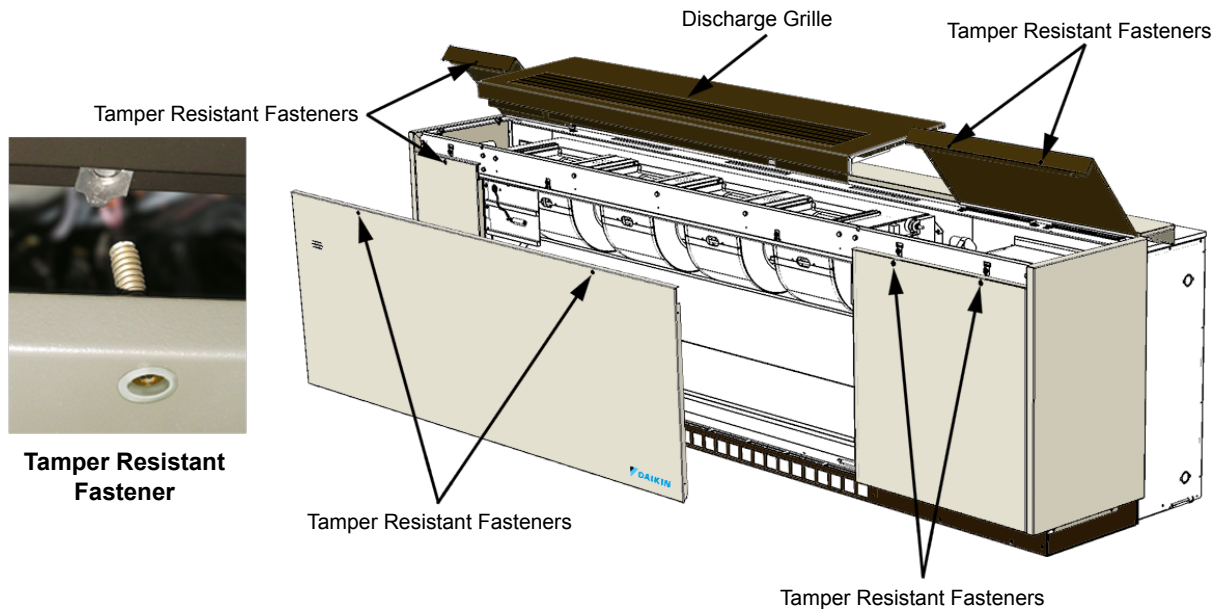

Figure 12: Easy Access with Tamper-Resistant Fasteners



## Built To Last

Our industrial-strength design provides the durability to withstand the rigors of the classroom environment. Its solid construction and rugged finish promotes continued alignment, structural strength and long-lasting beauty decades after the unit is installed. In fact, many units installed over 30 years ago continue to provide quiet, reliable classroom comfort.

## Heavy Duty Frame Construction

Daikin's exclusive, unitized frame (Figure 13 on page 13) is far superior to the fastener-type construction used by other manufacturers. Loosened fasteners can cause vibration, rattles and sagging panels. With unitized construction, there are no fasteners (screws or bolts) to come loose.

Other design features that promote trouble-free operation and long life include:

- A corrosion-resistant, galvanized-steel frame.
- Extra-strength, steel-bar discharge grille.
- Heavy-gauge-metal cabinet access panels and doors.
- An extra-strength pipe tunnel that stiffens the structure while adding aerodynamic air flow within the unit.
- Hidden reinforcement that provides additional built-in support for the top section as well as better support for the fan deck assembly.
- A rigid exterior that is strong enough to support maintenance personnel without fear of damaging the unit.

## Rugged Exterior Finish

The superior finish of the unit ventilator's cabinets fosters long-lasting beauty as well as resistance to abuse and corrosion. We apply the very highest standards at every step of the finishing process to provide lasting quality:

- High-quality furniture steel is carefully inspected before painting. Scratches and marks that might show through are removed.
- After fabrication, the metal undergoes a five-stage cleaning and phosphatizing process to provide a good bonding surface and reduce the possibility of peeling or corrosion.
- A specially formulated, environmentally friendly, thermosetting urethane powder is applied electrostatically to the exterior panels. This film is oven-cured to provide correct chemical cross-linking and to obtain maximum scuff- and mar-resistance.
- The top of the unit is finished with a textured, non-glare and scuff-resistant, charcoal bronze electrostatic paint. End and front panels are available in a pleasing array of architectural colors.
- The Oxford brown steel kickplate is coated and baked with a thermosetting urethane powder paint to blend with floor moldings and provide years of trouble-free service.
- Each unit is painstakingly inspected before boxing, then encapsulated in a clear plastic bag, surrounded by an extra-heavy-duty cardboard box and secured to a skid to help provide damage-free shipment.

**Figure 13: Heavy-Duty, Welded Chassis**

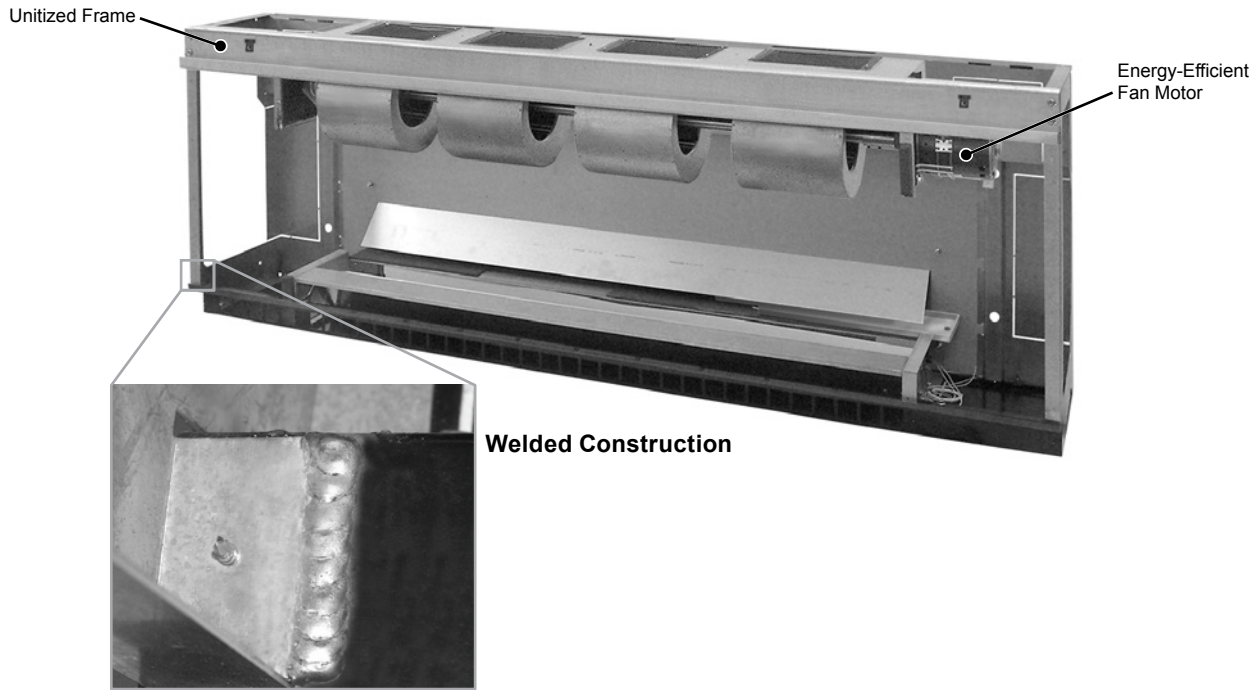

**Durable, Energy Efficient Fan Motors**

Daikin Applied unit ventilators are equipped with 115/60/1 NEMA motors that feature low operating current and wattage (Figure 14).

**Figure 14: Energy-Efficient Fan Motor**

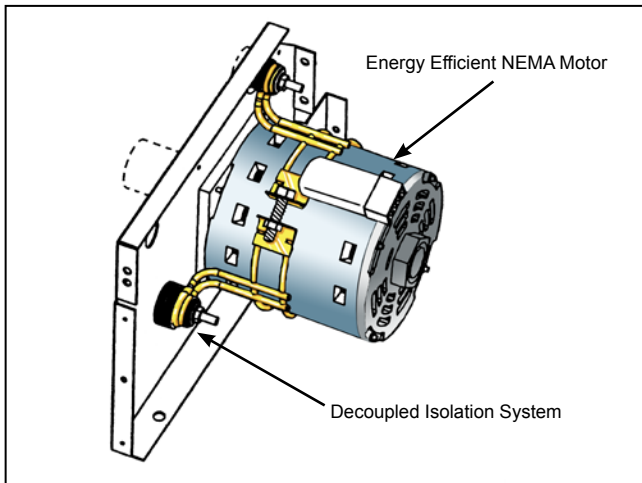

Additional features of these motors include:

- Split-capacitor (PSC) design with automatic reset and thermal-overload protection.
- No brushes, contacts or centrifugal starting switches the most common causes of motor failure.
- A built-in, decoupled isolation system to reduce transmission of vibrations for quieter operation.
- A multi-tap, auto-transformer (Figure 15) provides multiple fan motor speed control through the speed switch. The motor is independent of supply voltage, which allows stocking of one motor (school district-wide) for various voltage applications.

**Figure 15: Multi-Tap Auto-Transformer**

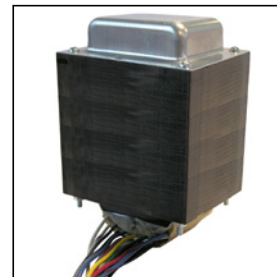

### Durable Damper Design

All dampers in Daikin Unit Ventilators use the turned-metal principle on their long closing edges (Figure 16). Positive sealing is provided by embedding the edge into wool mohair (no metal to metal contact). There are no plastic gaskets to become brittle with time, sag with heat or age, or require a difficult slot fit to seal. Nylon damper bearings foster quiet, maintenance-free operation.

**Additional features include:**

- Outdoor air dampers are made of galvanized steel to inhibit corrosion, with double-wall welded construction for rigidity and encapsulated insulation (Figure 16). Additional insulation is provided on the exterior of the outdoor air damper blade and on the outdoor air entry portion of the unit.

**Figure 16: Outdoor Damper Seals Out Cold Weather**

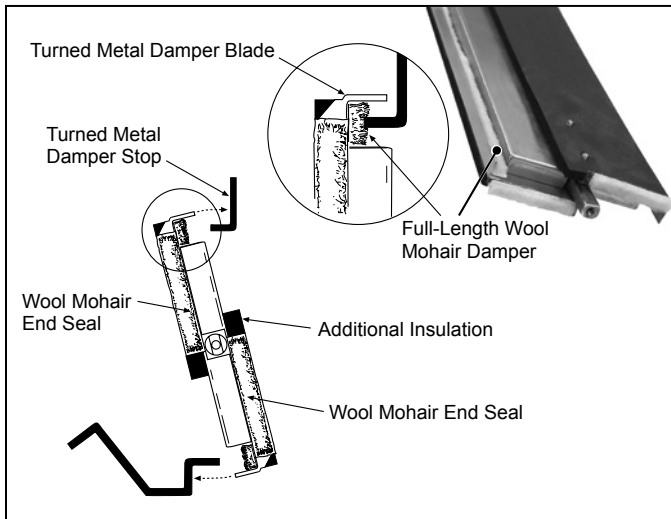

- Room air dampers are free-floating and designed to prevent intermittent gusts of cold air from blowing directly into the classroom on windy days (Figure 17). They are constructed of aluminum with built-in rigidity. The metal forming technique that is employed resists twisting and incorporates a full-length counter weight for easy rotation. The simple principle of an area exposed to a force is used to automatically close the damper, rather than open it, when gusts of cold air occur.

**Figure 17: Room Air Damper Auto-Closed by Wind Gusts**

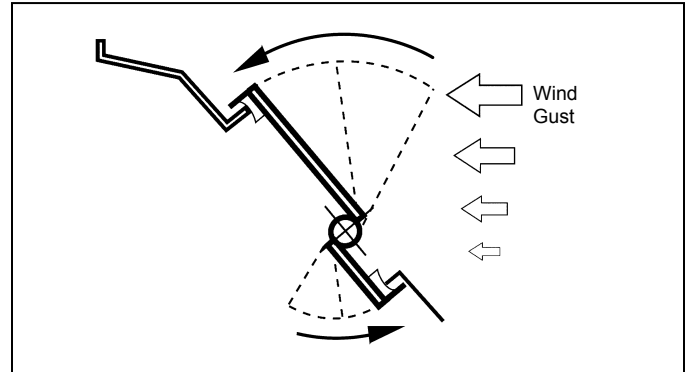

# Nomenclature

**U AZR 9 024 H G 12 Z B1 AL 22 G I B 1**  
 1 2 3 4 5 6 7 8 9 10 11 12 13 14 15

Category	Code Item	Code Option	Code Designation & Description									
<b>Product Category</b>	1	1	U	Unit Ventilators								
<b>Model Type</b>	2	2-4	AZU	Air Source DX, Valve Heating			AZQ	Air Source DX, Face & Bypass Heating				
			AZR	Air Source DX, Valve Reheat								
<b>Design Series</b>	3	5	9	Design J								
<b>Nominal Capacity</b>	4	6-8	024	24,000		044	44,000					
			036	36,000		054	54,000					
<b>Voltage</b>	5	9	C	208/60/1		D	208/60/3					
			G	230/60/1		H	230/60/3					
						K	460/60/3					
<b>Coil Options</b>	6	10	G	Direct Expansion		9	Direct Expansion with Stainless Steel Drain Pan					
			H	Direct Expansion with Refrigerant Relief Valve								
<b>Heating Options</b>	7	11-12	12	3 Element Low Cap. Electric Heat		68	Steam Low Cap.					
			13	6 Element Low Cap. Electric Heat		69	Steam High Cap.					
			65	1 Row HW		00	None					
			66	2 Row HW								
<b>Hand Orientation</b>	8	13	Z	Not Available								
<b>Controls</b> CO <sub>2</sub> = Return Air CO <sub>2</sub> Sensor	9	14-15	##	MicroTech Controls (see control code table below)								
			<b>Control Features</b>			<b>Feature Selections</b>						
			Open Protocol	BACnet / Stand-Alone	•		•		•	•		
				LONMARK		•		•			•	•
			DCV	CO <sub>2</sub> Sensor			•	•		•		•
			Factory-Installed Keypad	LUI					•	•	•	•
						<b>Control Code</b>						
			Economizer Control	Basic	B1	B5	B9	BD	BH	BL	BP	BT
				Expanded	E1	E5	E9	ED	EH	EL	EP	ET
				Leading-Edge	L1	L5	L9	LD	LH	LL	LP	LT
44	Electromechanical w/2-Position OA Damper for Remote Thermostat											
<b>Discharge</b>	10	16-17	AL	16-5/8" Top Bar Grille								
<b>Return Air/Outside Air</b>	11	18-19	22	Return Air Bottom Front/ Outdoor Air Rear								
<b>Power Connection</b>	12	20	G	Box With Switch								
			J	Box w/switch, w/USB								
			K	Box w/switch, w/SD								
			M	Box w/switch, w/USB, w/SD								
<b>Color</b>	13	21	I	Antique Ivory		G	Soft Gray					
			W	Off White		C	Cupola White					
			B	Putty Beige								
<b>SKU Type</b>	14	22	B	Standard Delivery								
<b>Product Style</b>	15	23	1	1st Style Change								

## Model Types

### AZU – Valve Control

On model type AZU units the full airflow is directed across the coil(s) at all times. In the heating mode the discharge air temperature is controlled modulating the heating valve. In units with heat the heating coil will be positioned before the cooling coil. The exception to this rule is on units with electric heat or a steam coil, which are always installed after the cooling coil.

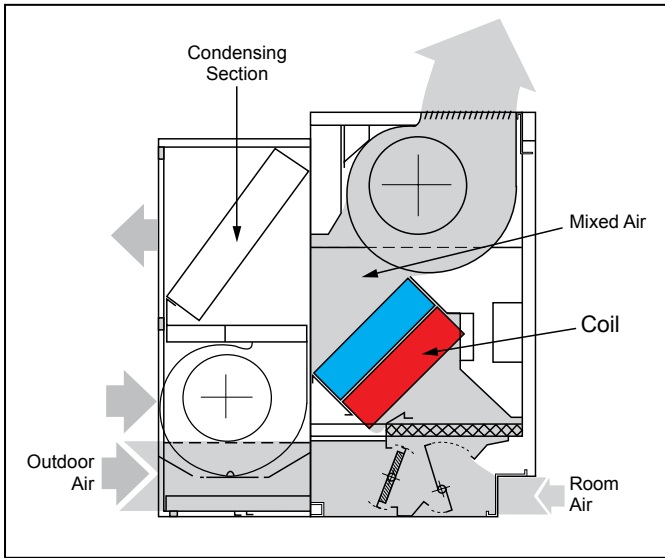

### AZQ – Face & Bypass

The model type AZQ units include a face and bypass damper. In the heating mode the discharge air temperature is controlled by varying the portion of the airflow going across the active coil. By modulating the damper position a portion of the airflow is bypassed around the heating coil. In the cooling mode that damper will be positioned to provide full airflow across the coil. The AZQ models are available with hot water or steam heating coils.

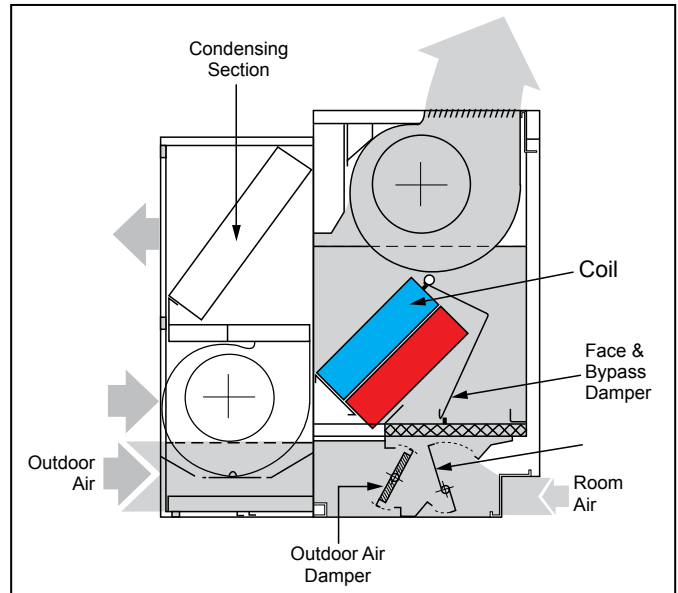

### AZR – Valve Control, Reheat

On model type AZR units the full airflow is directed across the coil(s) at all times. In the heating mode the discharge air temperature is controlled by modulating the heating valve. Model AZR units will always have a heating coil positioned after the cooling coil to allow for dehumidification with reheat capability. Units with factory installed controls will include a return air humidity sensor.

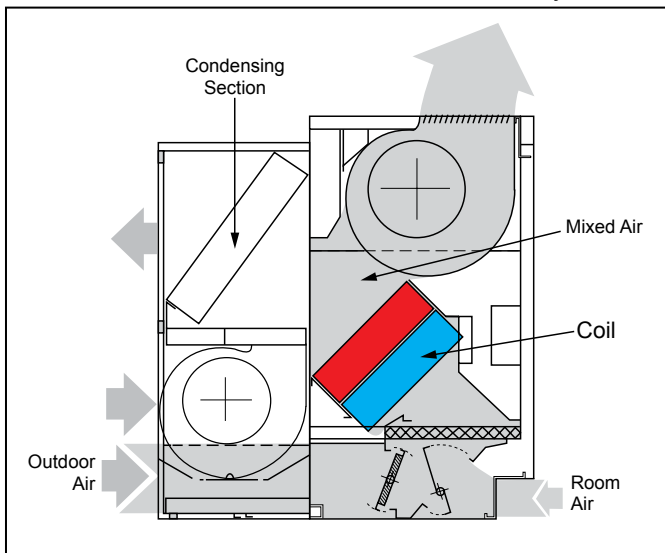



## MicroTech® Controls

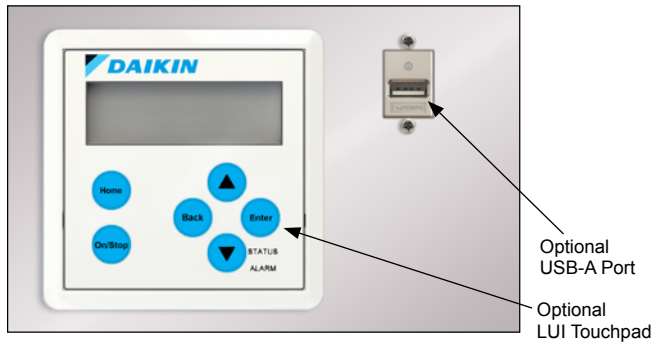

Daikin unit ventilators equipped with MicroTech unit control can provide superior performance and easy integration into your building automation system of choice. MicroTech benefits include:

- Factory integrated and tested controller, sensor, actuator and unit options promote quick, reliable start-up and minimize costly field commissioning.
- High-performance features and advanced control options can quickly pay for themselves in saved energy costs and more comfortable classrooms.
- Select from three control levels: stand-alone, client-server or network control.
- For network control applications, our Protocol Selectability feature provides easy, low-cost integration of Daikin unit ventilators into most building automation systems.
- Flexible BAS network communication options guard against controls obsolescence, keeping MicroTech controls viable for the life of your Daikin equipment.

### Three Control Levels

MicroTech unit controllers provide the flexibility to operate Daikin unit ventilators on any of two levels:

- As stand-alone units, with control either at the unit or from a wall sensor.
- Controlled as part of a network using a centralized building automation system.
- In a client-server relationship, where client units follow the server unit for some or all functions.

### Stand-Alone Control

When operating in stand-alone mode, the MicroTech controller performs complete room temperature and ventilation control. Units can be operated in occupied, unoccupied, stand-by, or bypass (tenant override) modes. Occupied/unoccupied changeover can be accomplished:

- Automatically by an internal daily schedule (two occupied times and two unoccupied times for each of the seven days, and one holiday schedule)
- Using a field-wired occupancy sensor.

If a school has more than one zone, separate, internally-programmed schedules are used to regulate each zone.

### Client-Server Control

Designate the server and client units and we will factory configure and install the controllers so they are set up for a local peer-to-peer network between units (leaving only the network wiring between these units to be field installed).

Client units can be field-configured to be dependent or independent as follows:

- Dependent client units follow the server unit completely. They are ideal for large spaces that have even loads across the space (such as some libraries).
- Independent client units (default) use server setpoints and client sensors. The client follows the server unit modes, such as heat or cool, but has the flexibility to provide the conditioning required for its area within the space. Independent client units perform better in spaces where loads vary from one area of the space to the other (such as stairwells or cafeterias).

### Network Control

MicroTech unit controllers provide easy integration into your building automation system of choice. All factory-installed options are handled by the unit controller. This simplifies the transmission of monitoring and setpoint data to the building automation system.

MicroTech controls have on-board BACnet communication, with optional LONTALK, to communicate control and monitoring information to your BAS, without the need for costly gateways (see "[Communication Types](#)" on page 75).

Flexible network communication options via our Protocol Selectability feature help you avoid control obsolescence over the life of your Daikin equipment.

### USB Interface

An optional USB-A port can be factory-configured. This option simplifies field access to the MicroTech controller. The USB interface can be used for downloading code, changing unit configuration, accessing external memory, or a field-connection to run the service tool. Technicians will have access to read all inputs, download code, setup/download trend data, and backup, restore, or change unit configuration.

### SD Card

An optional SD card can be factory configured. The SD card allows storage of data trending and configuration parameters. For further details see [page 79](#).

## Economizer Modes

Economizer operation is facilitated by the outdoor air damper, which automatically adjusts the above-minimum outside air position to provide free cooling when the outdoor air temperature is appropriate. Three levels of economizer control are available:

**Basic Economizer Operation:** The MicroTech controller compare the inside and outside temperatures. If the temperature comparison is satisfactory, then free- air economizer operation is used to cool the space. Reheat units also come configured with an indoor humidity sensor.

**Expanded Economizer Operation:** In addition to comparing inside and outside temperatures, outdoor relative humidity is measured to calculate outside air enthalpy. If the enthalpy set point is not exceeded, and the temperature comparison is satisfactory, then free economizer operation is used to cool the space. This helps to minimize the entrance of humid outside air.

**Leading-Edge Economizer Operation:** The MicroTech controller compare both indoor and outdoor temperatures and indoor and outdoor relative humidities. Then it calculates both inside and outside air enthalpy to determine if free economizer operation can cool the space with non-humid outside air. This is a true enthalpy economizer—a first for unit ventilators.

## Demand Control Ventilation

The optional unit mounted, single beam absorption infrared gas sensor has a sensing range of 0 – 2000 ppm and voltage output of 0 to 10 VDC (100 ohm output impedance). The pitot tube sensing device is located in the unit ventilator's return air stream. The optional CO<sub>2</sub> sensor is used with the UVC's Demand Control Ventilation feature to vary the amount of outside air based on actual room occupancy. With network applications, the unit mounted sensor can be overridden by a remote sensor through the network.

**Figure 18: Optional CO<sub>2</sub> Sensor**



## End Panels

Daikin end panels can be used to match up Daikin Applied unit ventilators with existing furniture or units, or with field-supplied storage, sink and bubbler cabinet offerings

One-inch end panels (Figure 19) are typically used to finish off stand-alone floor units. Six-inch end panels, with kick plates, can be used to provide extra space needed for piping (Figure 20). All end panels are individually wrapped in plastic and boxed to help prevent damage during construction.

Figure 19: 1" End Panel

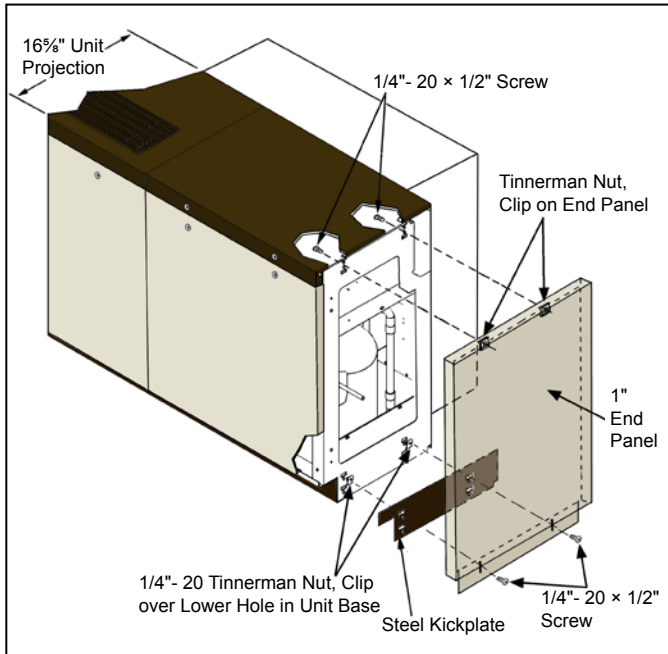
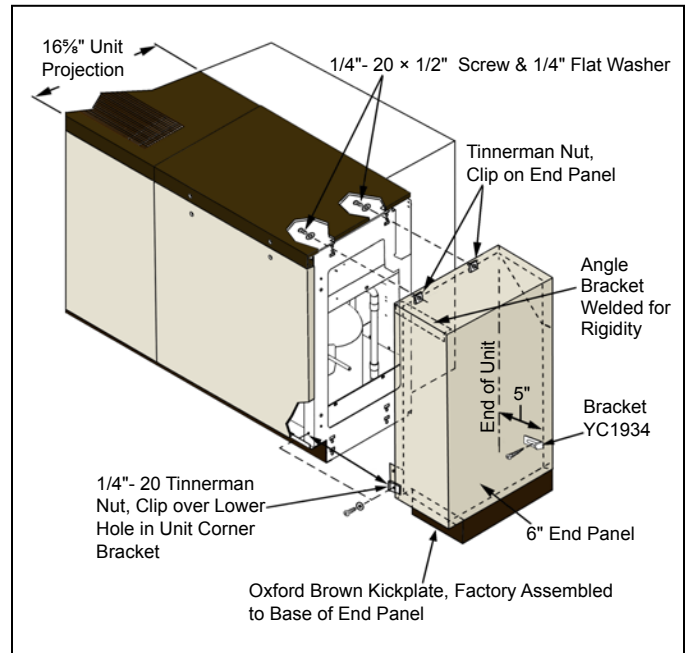
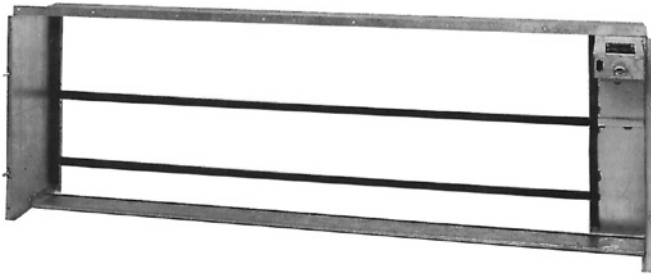

Figure 20: 6" End Panel



# Wall Sleeves



The Daikin wall sleeve and louver design is based on a "wet sleeve" concept. In brief, this means the design accommodates the penetration of some moisture into the rear outdoor section of the AZ unit with provisions for containment and disposal of this moisture to the outdoors. Therefore, proper Louver, Splitter and Wall Sleeve installation is critical.

The wall sleeve must be installed before the AZ self-contained unit ventilator can be placed. The recessed portion of the wall sleeve measures approximately 84", 96" or 108" wide by 28" high and may be recessed into

the wall up to 11<sup>3</sup>/<sub>8</sub>" in depth. Consult approved Daikin Applied submittal drawings for the job to determine the proper amount of recess, if any, and recommended wall opening size.

The AZ unit chassis attaches to the wall sleeve threaded studs using 4-nuts and washers.

**Table 1: Wall Sleeve Dimensions for Figure 21**

Unit Size	Overall Length "L" (mm)	Sleeve Recess Length "Lr" (mm)
024	86 (2184)	84 (2145)
036	98 (2489)	96 (2450)
044, 054	110 (2794)	108 (2755)

**Table 2: Recommended Rough-In Wall Opening**

Unit Size	Recommended Wall Opening	
	Length (mm)	Height (mm)
024	84 <sup>1</sup> / <sub>2</sub> " (2146)	28 <sup>1</sup> / <sub>2</sub> " (724)
036	96 <sup>1</sup> / <sub>2</sub> " (2451)	
044, 054	108 <sup>1</sup> / <sub>2</sub> " (2756)	

**Figure 21: Wall Sleeve Details (Recessed Type Shown)**

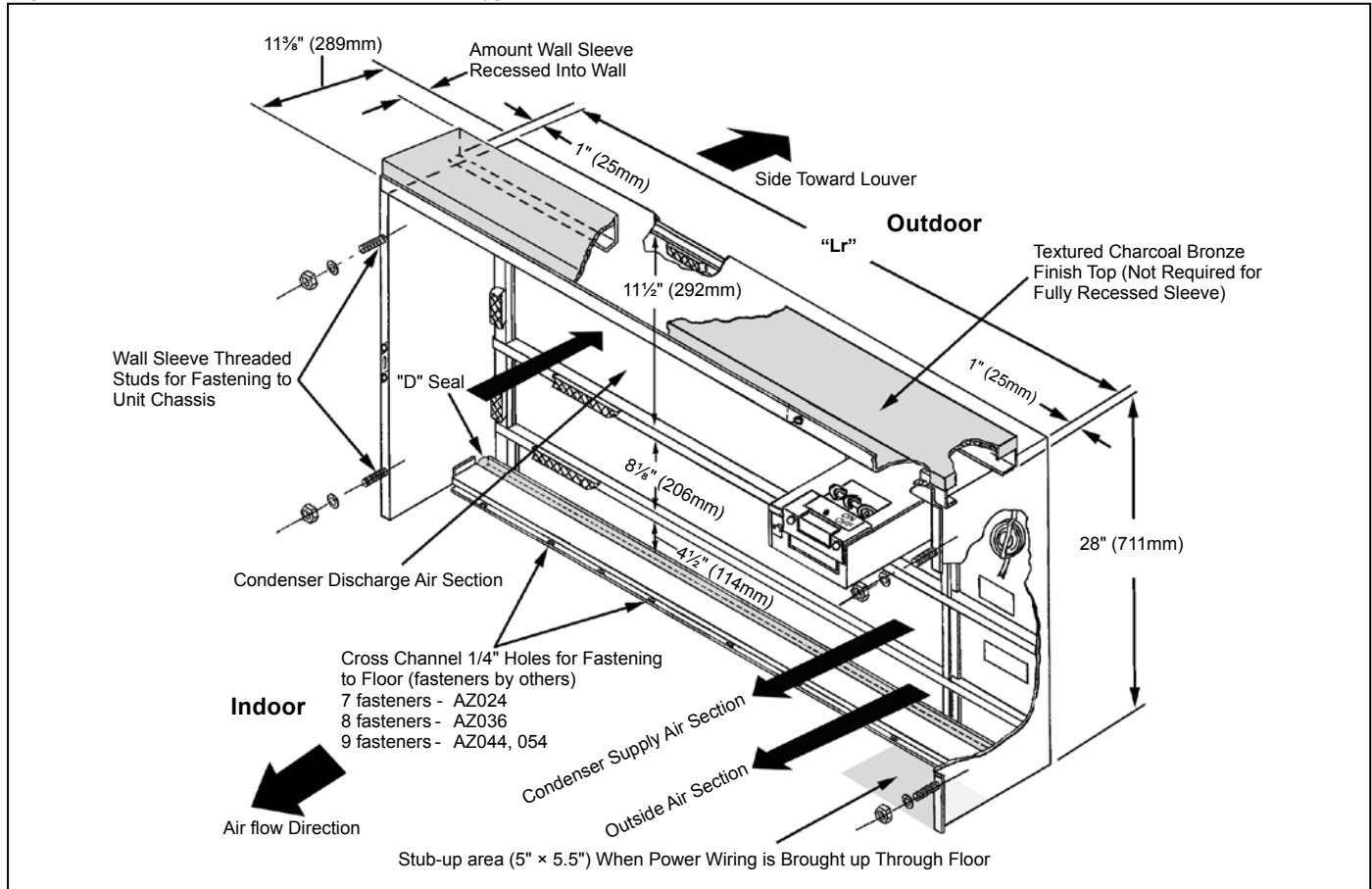

## Wall Louvers & Grilles

The standard aluminum louver frame is divided in half horizontally, with make-up and discharge-air stream sections to reduce air recirculation within the vertical louver blade. The upper half of the louver has a blockoff on the exterior side to increase discharge air velocity and improve the throw of leaving air.

The vertical louver can be ordered with flanges that are attached on the outside of all four sides of the louver, resulting in a vertical dimension of 30" (762 mm). Weep holes exist behind the bottom flange of the louver. A diamond pattern expanded aluminum wire mesh (bird screen) is provided on the interior surface of the louver.

The vertical louver is fabricated from extruded 6063-T5 aluminum. The single piece blade has a turned edge along the entering and leaving surface to reduce visibility of the outdoor coil and fan section, and adds rigidity to the blade. The 72-degree offset bend near the middle of the blade creates an air-path turn that minimizes moisture carryover, with a total blade depth of 2¼" (57 mm) in direction of airflow.

**Figure 22: Typical Wall Louver and Grille**

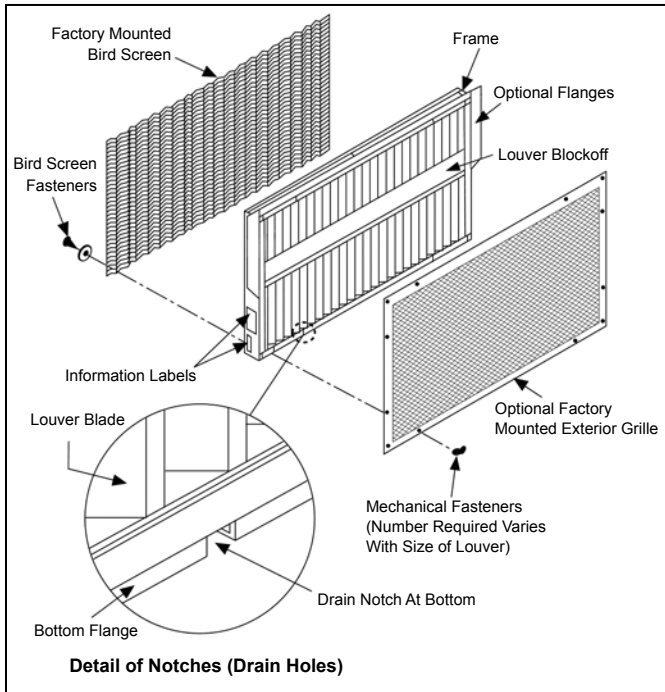

The louver is available in the following colors:

- Natural Aluminum finish (paintable 6063-T5 Aluminum)
- Autumn Brown - thermosetting urethane powder coat paint electrostatically applied and oven-cured to provide correct chemical cross-linking.
- Dark Bronze - thermosetting urethane powder coat paint electrostatically applied and oven-cured to provide correct chemical cross-linking.
- Clear Anodized Aluminum finish

**Figure 23: Vertical Blade Louver Outside View, without Flange**

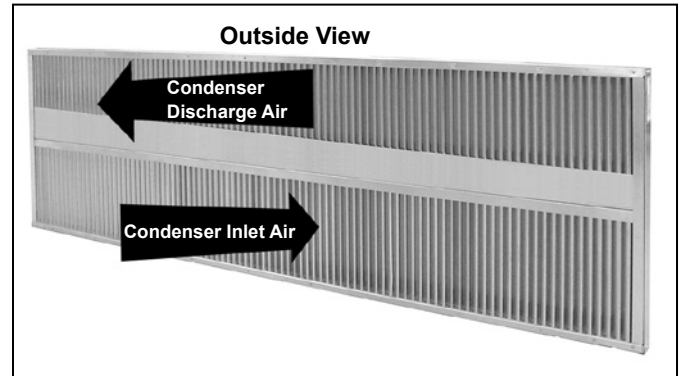

**Figure 24: Vertical Blade Louver Inside View, without Flange**

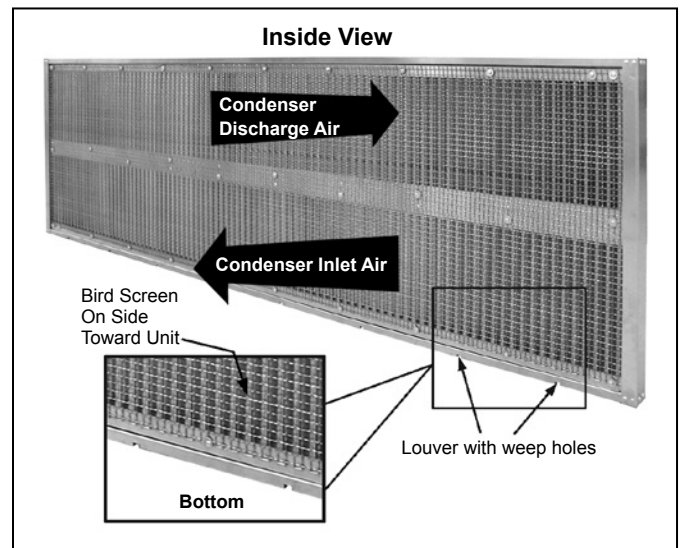

## Wall Intake Louvers & Grilles

Louvers are available with a vertical blade configuration, constructed of heavy-gauge (unpainted, painted, or clear anodized) aluminum.

- The louver is divided in half horizontally to prevent condenser air recirculation.
- A bird screen is provided on the leaving air side of the intake louver.
- Louvers can be supplied with or without flanges:
- Flanged louvers are typically used for a panel wall finish.
- Unflanged louvers are typically used for recessing into a masonry wall.
- An optional (factory-mounted) heavy-duty lattice exterior grille is available with horizontal and vertical lines that “line up” with the louver blades to present an aesthetic appearance.
- Louvers are available in both horizontal and vertical blade configurations:

Figure 25: Typical Wall Louver and Grille

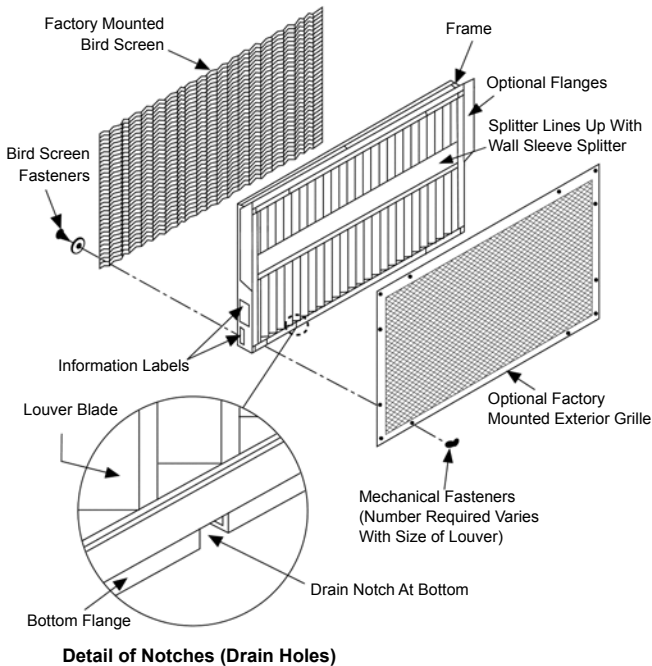

Figure 26: Vertical Blade Louver, Without Flange

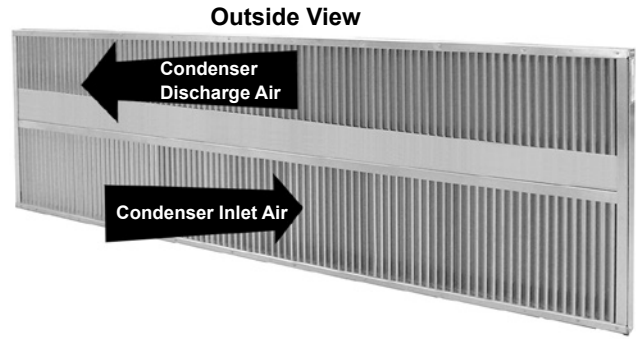

Figure 27: Grille Detail

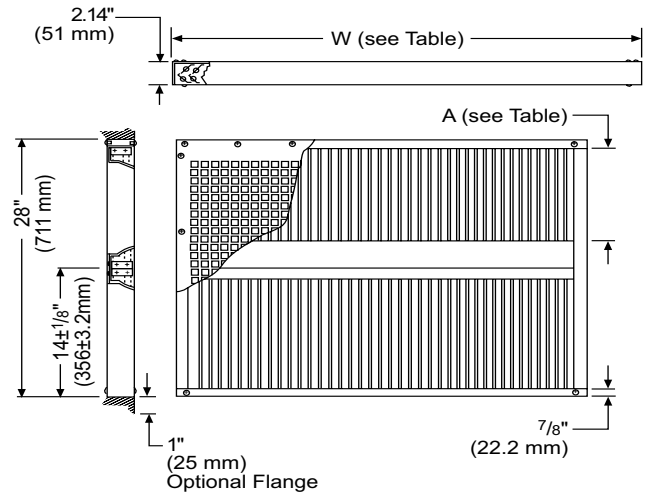
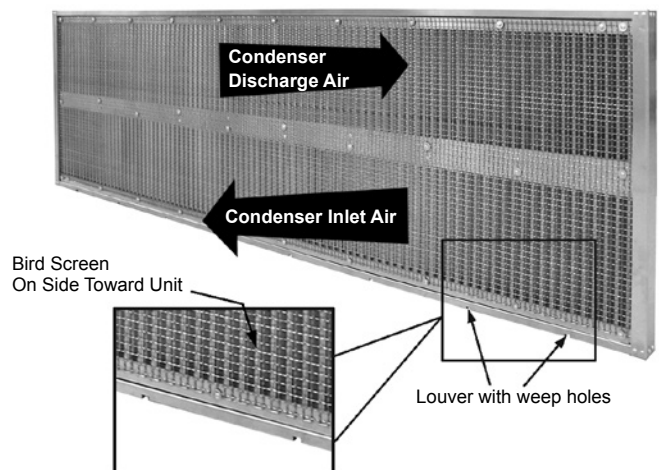

Table 3: Wall Louver Dimensions (W)

Unit Size	Louver Size (Height x W)	Discharge Air Opening (A)
024	28" × 84" (711 × 2134)	9" (229mm)
036	28" × 96" (711 × 2438)	9" (229mm)
044, 054	28" × 108" (711 × 2743)	7" (178mm)

**Note:** All dimensions are approximate and subject to change without notice. Refer to approved submittal prints for rough-in details and construction purposes, and for recommended wall opening size.

Figure 28: Vertical Blade Louver, without Flange Inside View



## VentiMatic Shutter Room Exhaust Ventilation

Outdoor air introduced by the unit ventilator must leave the room in some way. In some states, exhaust vents are required by law or code to accomplish this. The VentiMatic Shutter is a more economical solution to the problem.

- The VentiMatic shutter is a continuously variable, gravity-actuated room exhaust vent (Figure 29). It operates in direct response to positive static air pressure created when ventilation air is brought into the room by the unit ventilator. It is a “one-way” shutter that opposes any flow of air into the room.

**Figure 29: VentiMatic Shutter**

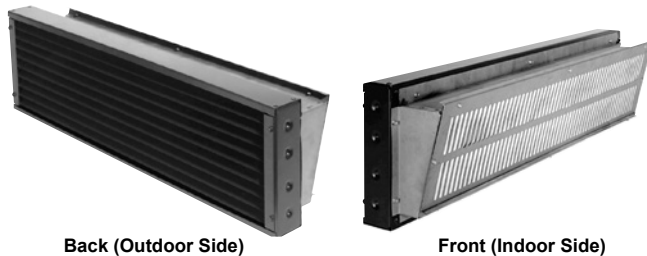

The VentiMatic Shutter's ability to exhaust only the amount of air required results in considerable energy savings. In the heating mode, the unit ventilator will be able to bring in only the required percent minimum outdoor air. Unlike systems that rely on powered exhaust, no energy will be wasted heating excess outdoor air. In the cooling mode, the unit ventilator will be able to bring in 100% outdoor air for full natural or free cooling when it is energy effective.

Since it is not powered, VentiMatic Shutter operation is inherently silent. Unlike other non-powered vents, it opens at an extremely low positive pressure (0.005"). Its shutter flaps are made of temperature-resistant glass fabric impregnated with silicone rubber for flexibility and long life. This fabric retains its original properties down to -50°F.

# VentiMatic Shutter Assembly

**Notes:**

- 1 Horizontal blade louver shown. Vertical blade louver also available with VentiMatic shutter.
- 2 Optional exterior grille matches unit ventilator louver in material and design. Mounted in wall louver.
- 3 Optional interior grille mounting hardware is not included.
- 4 Louver leaves seal against plate to prevent air infiltration.

**Figure 30: VentiMatic Shutter Assembly with Optional Grille**

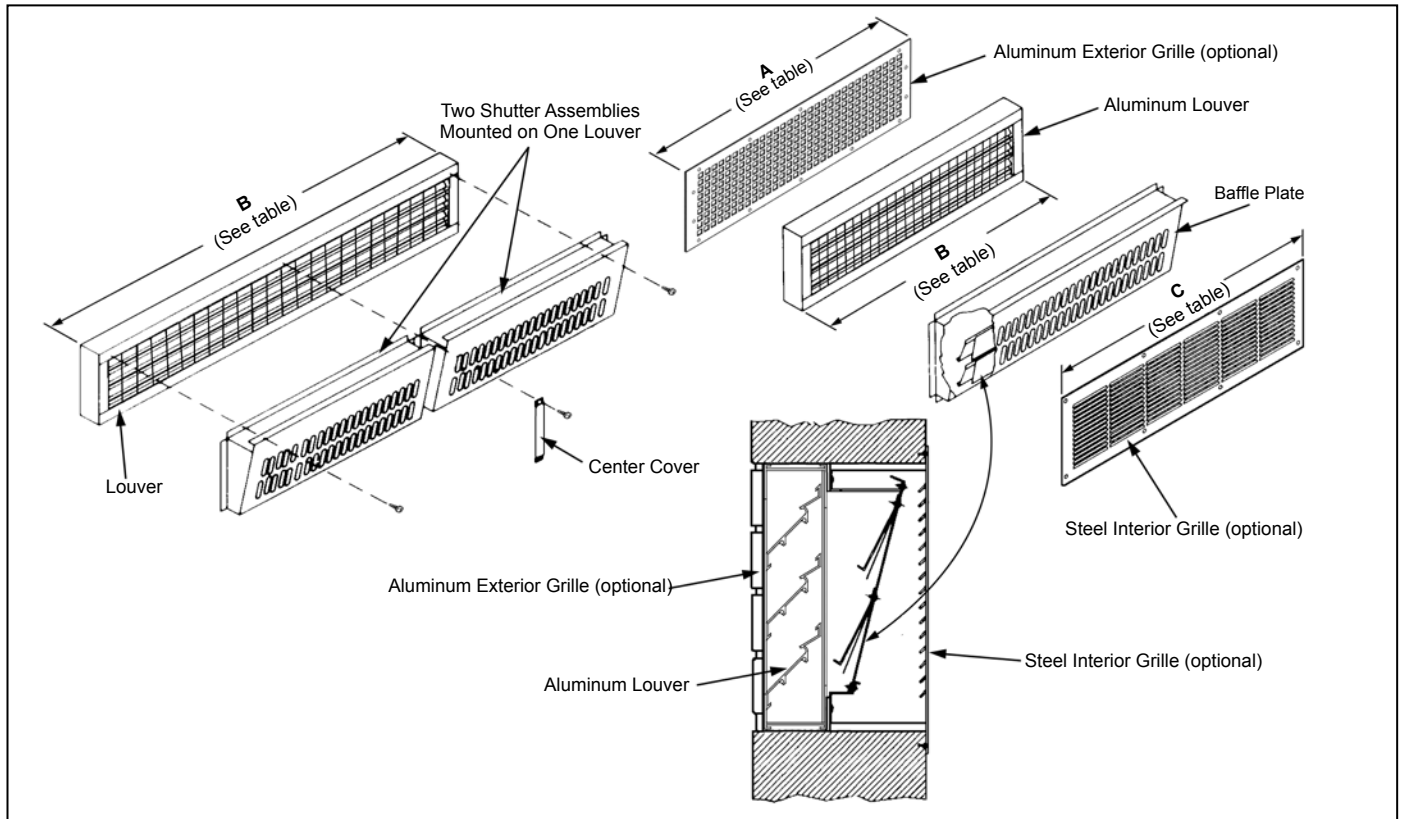

**Table 4: VentiMatic Shutter Assembly Dimensions & Maximum Air Capacities**

Exterior Grille "A"		Louver Width "B"		Interior Grille Width "C"		Recommended Wall Opening For Shutter				Max. Number of VentiMatic Shutters to Mount on Standard Louver		VentiMatic Shutter(s) Max. Air Capacity	
inches	mm	inches	mm	inches	mm	Length		Width		24" (610mm) Shutter	36" (914mm) Shutter	CFM	L/s
						inches	mm	inches	mm				
23¾	603	24	610	27	686	24¾	616	10½	267	1	0	500	236
36¾	933	36	914	39	991	36¾	921			0	1	750	354
47¾	1213	48	1219	51	1295	48¾	1225			2	0	1000	472
59¾	1518	60	1524	63	1600	60¾	1530			1	1	1250	590
71¾	1822	72	1829	75	1905	72¾	1835			0	2	1500	708



# Physical Data

**Table 5: AZ General Data**

			024	036	044	054
Fan Data	Nominal CFM (L/s)	High Speed	1000 (472)	1250 (590)	1500 (708)	1500 (708)
		Medium speed	750 (354)	1000 (472)	1150 (543)	1150 (543)
		Low Speed	650 (307)	800 (378)	950 (448)	950 (448)
	Number of Fans		3	4	4	4
	Size	Diameter - in (mm)	8.12 (206mm)	8.12 (206mm)	8.12 (206mm)	8.12 (206mm)
		Width- in (mm)	8.25 (210mm)	8.25 (210mm)	8.25 (210mm)	8.25 (210mm)
Room Fan Motor Horsepower			1/4	1/4	1/4	1/4
Outdoor Fan Motor Horsepower			1/3	1/3	3/4	3/4
Filter Data	Nominal Size	in	10 × 48½ × 1	10 × 60½ × 1	(2) 10 × 36½ × 1	(2) 10 × 36½ × 1
		(mm)	254 × 1232 × 25	254 × 1537 × 25	(2) 254 × 927 × 25	(2) 254 × 927 × 25
	Area - Ft2 (m2):		3.37 (.31)	4.2 (.39)	5.08 (.47)	5.08 (.47)
	Quantity		1	1	2	2
Shipping Weight	lb (kg)		885 (402)	975 (442)	1075 (448)	1075 (448)
Refrigerant Charge	oz		124	135	145	147
Coil Water Volume Gallons (Liters)	1 Row Coil		0.25 (0.95)	0.31 (1.17)	0.38 (1.44)	0.44 (1.67)
	2 Row Coil		0.45 (1.70)	0.57 (2.16)	0.69 (2.61)	0.82 (3.10)

# Model AZ Self-Contained – Size 024

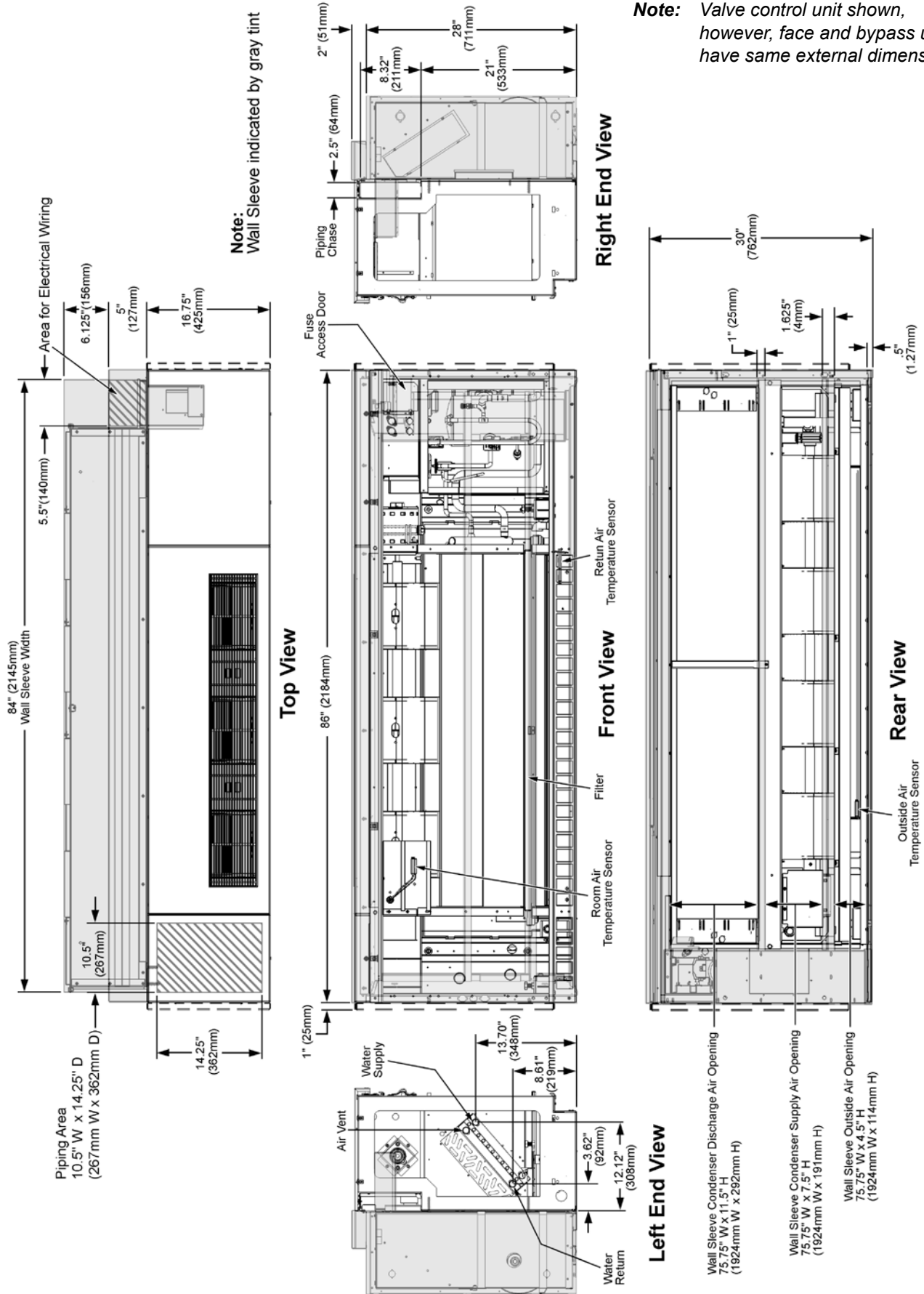

Model AZ Self-Contained – Size 036

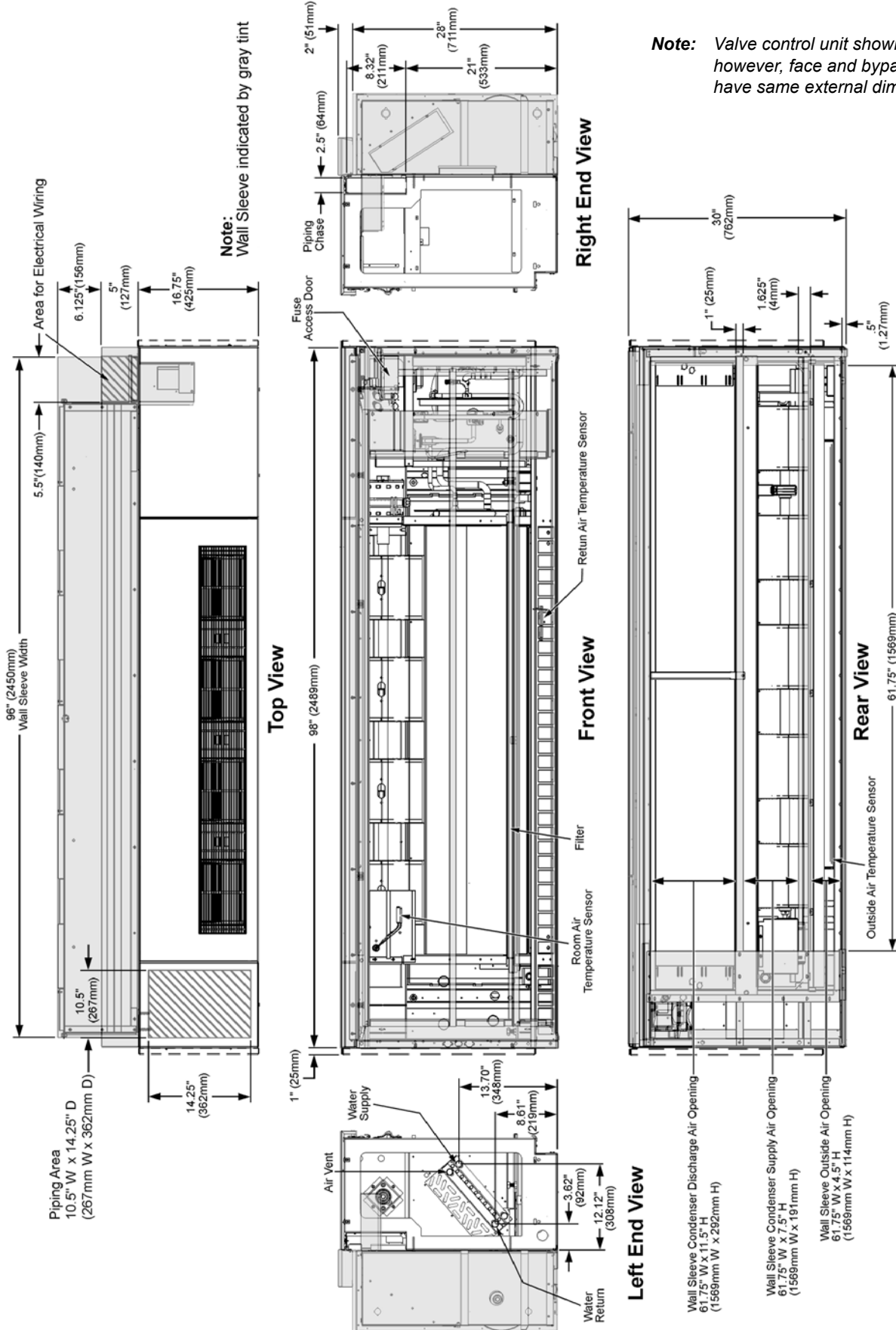

Note: Valve control unit shown, however, face and bypass units have same external dimensions.

# Model AZ Self-Contained – Sizes 044, 054

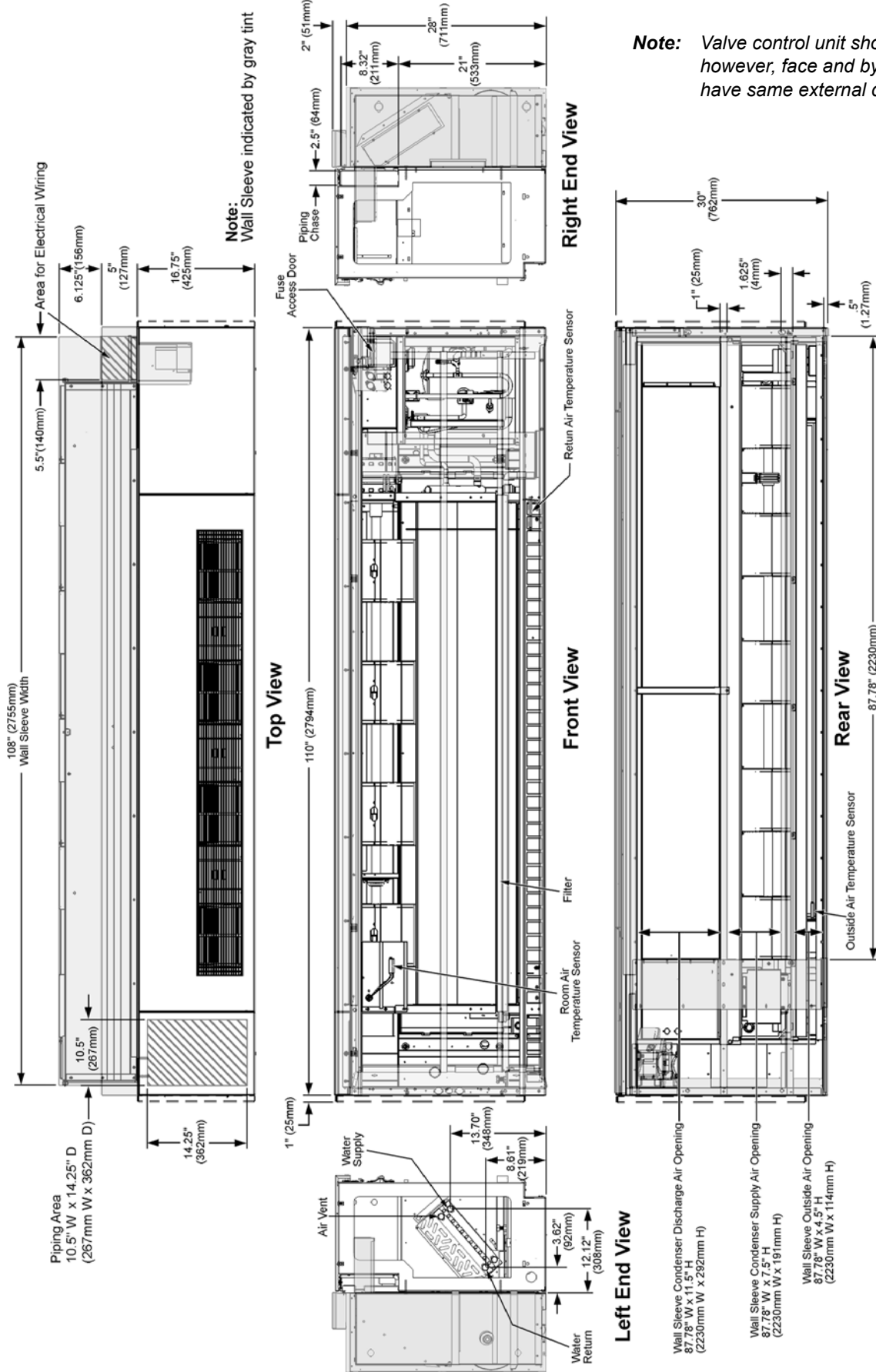

**Note:** Valve control unit shown, however, face and bypass units have same external dimensions.

# AZU and AZQ Hot Water Coil Connection Locations

The following notes apply to hot water coil units:

- 1 All coils have same-end supply and return connections.
- 2 All coils have the supply and return connections in the left hand compartment.
- 3 Hot Water connections are on the left end.
- 4 Coil connections are 7/8" I.D. (female) and terminate 9" (229mm) from the end of the unit.
- 5 Shading indicates portion of unit wall sleeve recessed into wall opening.
- 6 All dimensions are approximate.

## Left End Views

### Heating Coils

65 = 1-Row Hot Water Coil

66 = 2-Row Hot Water Coil

S = Supply

R = Return

Figure 31: Hot Water Coil Connections – 28" Type

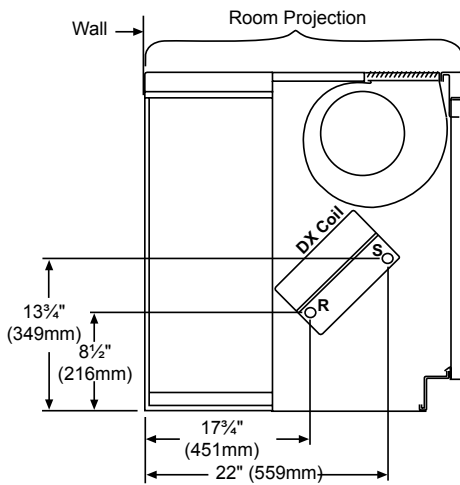

Figure 32: Hot Water Coil Connections – 21 7/8" Type

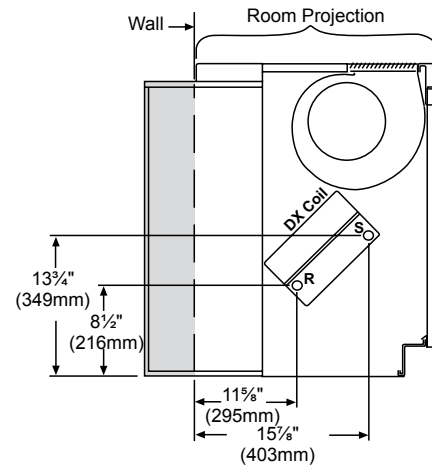

Figure 33: Hot Water Coil Connections – 19 5/8" Type

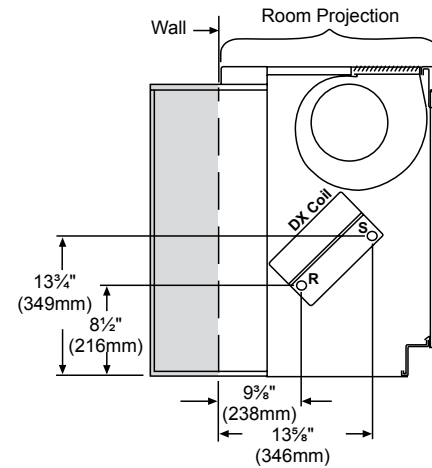
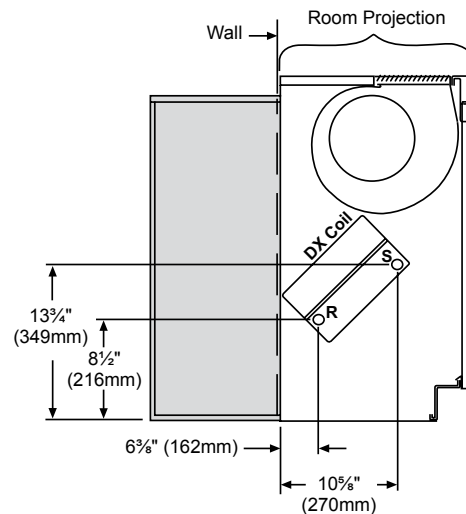

Figure 34: Hot Water Coil Connections – 16 5/8" Type



# AZR Hot Water Coil Connection Locations

The following notes apply to hot water coil units:

- 1 All coils have same-end supply and return connections.
- 2 All coils have the supply and return connections in the left hand compartment.
- 3 Hot Water connections are on the left end.
- 4 Coil connections are 7/8" I.D. (female) and terminate 9" (229mm) from the end of the unit.
- 5 Shading indicates portion of unit wall sleeve recessed into wall opening.
- 6 All dimensions are approximate.

## Left End Views

### Heating Coils

65 = 1-Row Hot Water Coil

66 = 2-Row Hot Water Coil

S = Supply

R = Return

Figure 35: Hot Water Coil Connections – 28" Type

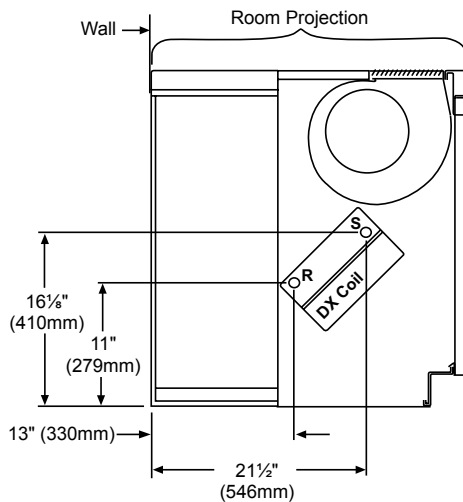

Figure 36: Hot Water Coil Connections – 21 1/8" Type

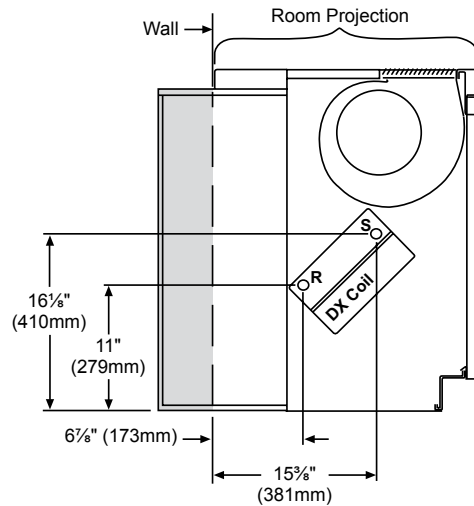

Figure 37: Hot Water Coil Connections – 19 5/8" Type

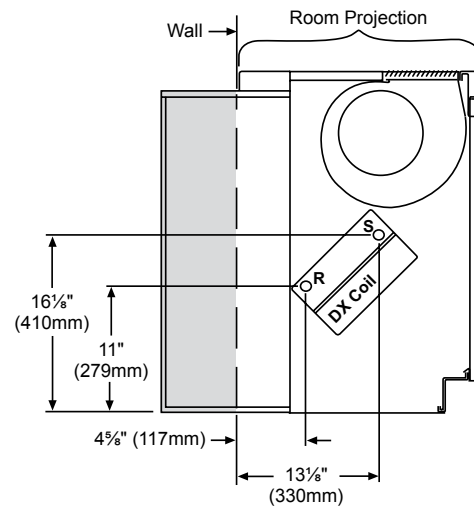
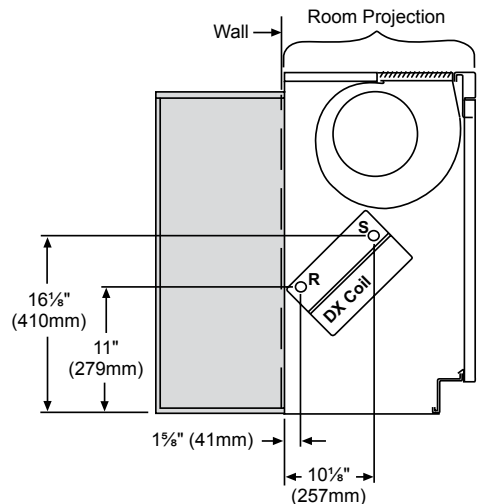

Figure 38: Hot Water Coil Connections – 16 5/8" Type



## AZU, AZR, and AZQ Steam Coil Connection Locations

The following notes apply to steam coil units:

- 1 All coils have same-end supply and return connections.
- 2 Steam coils have the supply and drain to steam trap connections in the left hand compartment.
- 3 Steam coils have a factory-installed pressure equalizing valve and a 24" (610mm) long pressure equalizing line which terminates in a 1/2" M.P.T. fitting.
- 4 Steam coils are 1-1/8" female (sweat) connections and terminate 9" (229mm) from the end of the unit.
- 5 Shading indicates portion of unit wall sleeve recessed into wall opening.
- 6 All dimensions are approximate.

### Left End Views

#### Heating Coils

68 = Low Capacity Steam Coil

69 = High Capacity Steam Coil

S = Supply

Figure 39: Steam Coil Connections – 28" Type

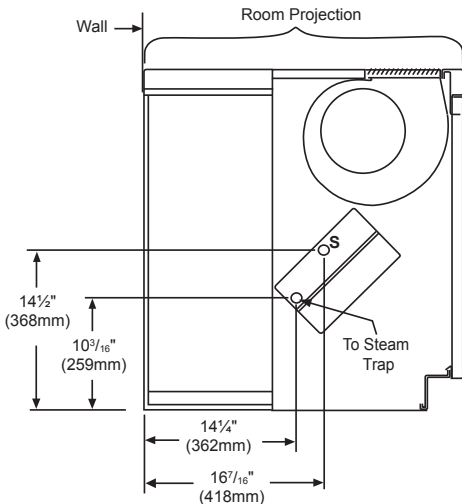

Figure 40: Steam Coil Connections – 21 7/8" Type

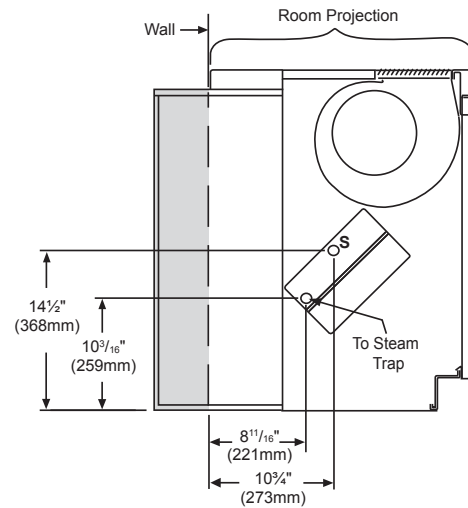

Figure 41: Steam Coil Connections – 19 5/8" Type

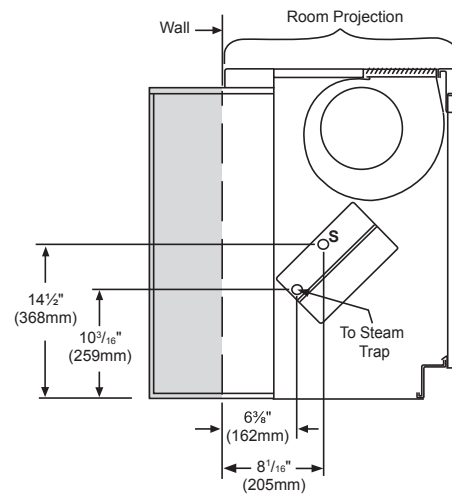
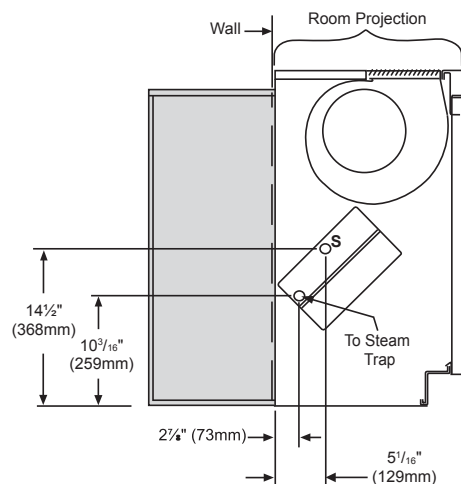

Figure 42: Steam Coil Connections – 16 5/8" Type



## End Panels

Figure 43: 1" (25mm) End Panel Dimensions

All Dim. in inches	16 <sup>5</sup> / <sub>8</sub> " (422mm) Deep End Panels	19 <sup>5</sup> / <sub>8</sub> " (498mm) Deep End Panels	21 <sup>7</sup> / <sub>8</sub> " (556mm) Deep End Panels	28" (711mm) Deep End Panels
Top View				
End View with No Cut-Out				

Figure 44: 6" (152mm) End Panel Dimensions

Top View				
End View with No Cut-Out				



## Face & Bypass End of Cycle Valves

### 2-Way End of Cycle Valve



When piping the 2-Way End of Cycle valve, refer to label to determine the direction of flow. The valve should be installed so that there is a 2" (51mm) minimum clearance to remove the actuator from the valve body. Provide unions for removal of unit coil and/or control valve as a future service consideration. Hot water connections may be same end as cooling coil connections, but are recommended to be opposite end to facilitate piping.

When using MicroTech® controls, they must be opposite end. The End of Cycle valve accessory must be field installed on the unit for which it was selected.

Figure 45: 2-Way EOC Valve Dimensions

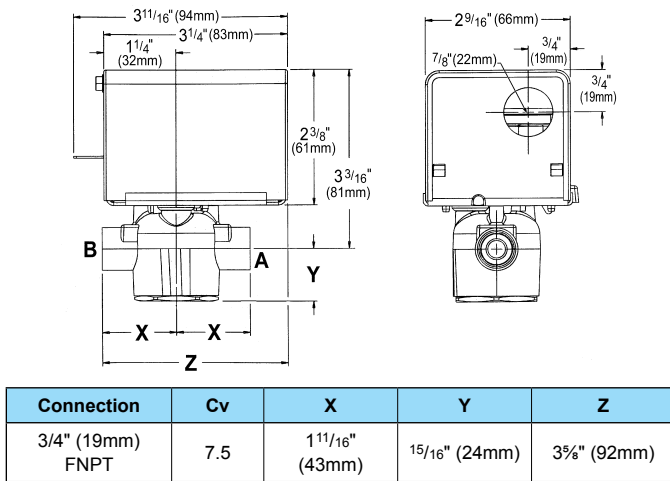

### 3-Way End of Cycle Valve



When piping the 3-Way End of Cycle valve, refer to label to determine the direction of flow. The valve should be installed so that there is a 2" (51mm) minimum clearance to remove the actuator from the valve body. Provide unions for removal of unit coil and/or control valve as

a future service consideration. Hot water connections may be same end as cooling coil connections, but are recommended to be opposite end to facilitate piping.

When using MicroTech® controls, they must be opposite end. The End of Cycle valve accessory must be field installed on the unit for which it was selected.

Figure 46: 3-Way EOC Valve Dimensions

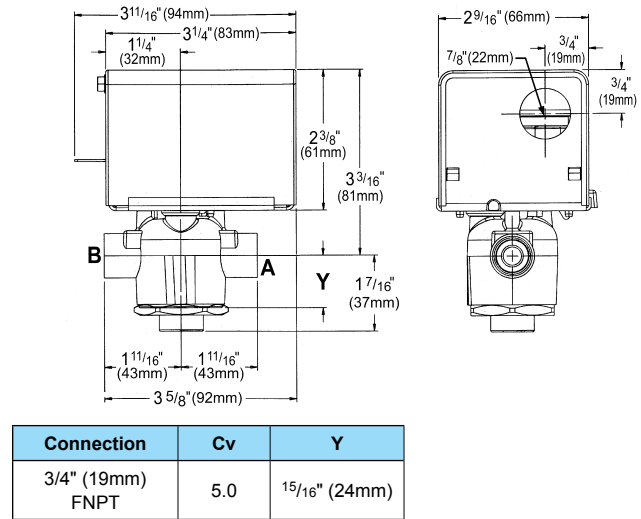

Figure 47: 2-Way EOC Steam Valve Dimensions

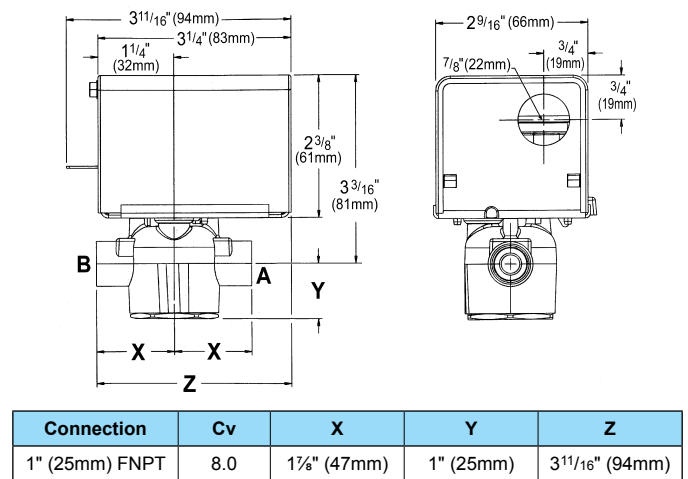

Table 6: EOC Actuator Specifications

Control	2 Position
Electrical	24 VAC, 50/60 Hz
Stroke	Power Stroke 9 to 11 seconds Spring return 4 to 5 seconds
Ambient	32°F to 125°F (0°C to 52°C)

Table 7: F&BP EOC Valve Body Specifications

	2-Way Valve	3-Way Valve
Connections	3/4" FNPT, 1" FNPT	3/4" FNPT
Static Pressure	300 psi (2100 kPa)	300 psi (2100 kPa)
Close-Off Pressure	13 & 15 psi (90 & 103 kPa)	13 psi (90 kPa)
Temperature	32°F to 200°F (0°C to 93°C)	32°F to 200°F (0°C to 93°C)

## Modulating Valves

### 2-Way Modulating Valve Hot Water Valve



Two-way modulating control valves for MicroTech are designed to regulate the flow of hot water. They consist of a nickel plated brass body and stainless steel ball valve and stem, with a spring return proportional actuator. The optional valve accessory is shipped separate from the unit ventilator for field installation to prevent shipping damage and to provide flexibility in making the field piping connection.

**Table 8: 2-Way Actuator Specifications (HW)**

Power Supply	24 VAC, ±20%, 50/60 Hz, 24 VDC, ±10%
Power Consumption Running	2 W
Power Consumption Holding	1 W
Transformer Sizing	4 VA (class 2 power source)
Electrical Connection	3ft [1m], 18 GA plenum cable with 1/2" conduit connector
Overload Protection	electronic throughout 0° to 95° rotation
Operating Range Y	2 to 10 VDC, 4 to 20 mA w/ ZG-R01 (500 Ω, 1/4 W resistor)
Input Impedance	100 k Ω for 2 to 10 VDC (0.1 mA), 500 Ω for 4 to 20 mA
Feedback Output U	2 to 10 VDC, 0.5 mA max
Angle of Rotation	Max. 95°, 90°
Direction of Rotation (Motor)	reversible with built-in switch
Direction of Rotation (Fail-Safe)	reversible with CW/CCW mounting
Position Indication	visual indicator, 0° to 95° (0° is full spring return position)
Running Time (Motor)	95 sec
Running Time (Fail-Safe)	<25 sec
Ambient Humidity	max. 95% RH non-condensing
Ambient Temperature Range	-22°F to 122°F [-30°C to 50°C]
Storage Temperature Range	-40°F to 176°F [-40°C to 80°C]
Housing	NEMA 2, IP42, UL Enclosure Type 2
Housing Material	UL94-5VA
Agency Listings <sup>1</sup>	cULus acc. to UL60730-1A/-2-14, CAN/CSA E60730-1:02, CE acc. to 2004/108/EC and 2006/95/EC
Noise Level (Motor)	<35 dB (A)
Noise Level (Fail-Safe)	<62 dB (A)
Servicing	maintenance free
Quality Standard	ISO 9001

**Note:** <sup>1</sup> Rated Impulse Voltage 800V, Type of action 1.AA, Control Pollution Degree 3TFRB24

**Table 9: 2-Way Valve Body Specifications (HW)**

Service	hot water, up to 60% glycol
Flow Characteristic	equal percentage
Controllable Flow Range	75°
Size [mm]	0.5" [15]
End Fitting	NPT female ends
Body	forged brass, nickel plated
Ball	stainless steel
Stem	stainless steel
Stem Packing	EPDM (lubricated)
Seat	Teflon® PTFE
Seat O-ring	EPDM (lubricated)
Characterized Disc	TEFZEL®
Body Pressure Rating [psi]	600
Media Temperature Range (Water)	0°F to 250°F [-18°C to 120°C]
Max Differential Pressure (Water)	50 psi (345 kPa)
Close-Off Pressure	200 psi
Leakage	0% for A to AB
Servicing	maintenance free

## 2-Way Modulating Hot Water Valve Specifications

### Modulating Valve Selection

The unit ventilator control valve is expected to be able to vary the quantity of water that flows through the coil in a modulating fashion. Any movement of the valve stem should produce some change in the amount of water that flows through the coil. Oversized control valves cannot do this. For example, assume that when the control valve is fully open, the pressure drop through the coil is twice as great as the drop through the valve. In this case, the control valve must travel to approximately 50% closed before it can begin to have any influence on the water flow through the coil. The control system, no matter how sophisticated,

cannot overcome this. Oversized control valves can also result in “hunting” which will shorten the life of the valve and actuator and possibly damage the coil.

To correctly select the proper Hot Water Modulating Valve:

1. Determine the flow of water and the corresponding pressure drop through the coil.
2. Obtain the pressure difference between the supply and return mains.
3. Select a valve size (Cv) from [Table 11](#), on the basis of taking 50% of the available pressure difference (at design flow) between the supply and return mains at the valve location. The valve should have a pressure drop greater than that of the coil.

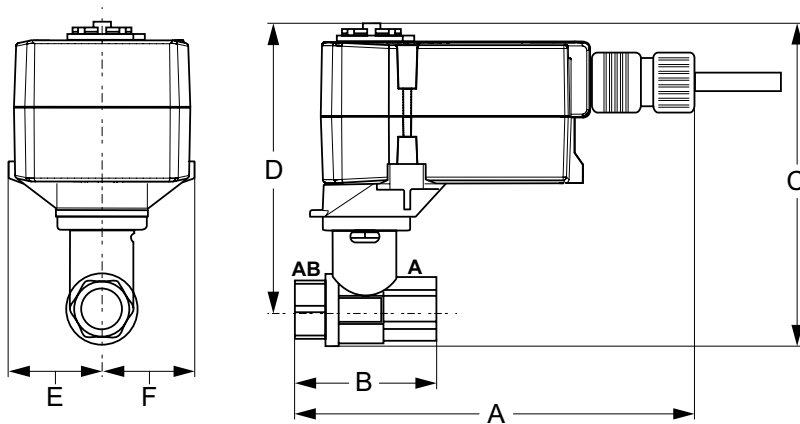

**Figure 48: Formula Equation to Calculate Cv**

Q = Capacity in gallons per minute

Cv = Valve sizing coefficient determined experimentally for each style and size of valve, using water at standard conditions as the test fluid

ΔP = Pressure differential in psi

G = Specific gravity of fluid (water at 60°F = 1.0000)

$$Cv = Q \sqrt{\frac{G}{\Delta P}}$$

**Table 10: 2-Way Modulating Valve Dimensions (HW)**

Valve Part No.	Cv	Connection Size (inches)	A	B	C	D	E	F	Weight	
									Valve Body	Actuator
B209	0.8	1/2"	6.59" (167mm)	2.38" (60mm)	4.9" (124mm)	4.32" (110mm)	1.53" (38mm)		0.4 lb (0.2 kg)	1.8 lb (0.8 kg)
B210	1.2									
B211	1.9									
B212	3.0									
B213	4.7									
B214	7.4									
			6.59" (167mm)	2.38" (60mm)	5.48" (139mm)	4.71" (120mm)	1.53" (38mm)		0.7 lb. (0.3 kg)	

**Note:** See "Table 8: 2-Way Actuator Specifications (HW)" on page 34" and "Table 9: 2-Way Valve Body Specifications (HW)" on page 34.

**Table 11: 2-Way Modulating Water Valve – Pressure Drop (HW)**

2-Way CCV Part No.	Cv Maximum Rating	Connection Size	Pressure Drop Across the Valve									
			1 PSI	2 PSI	3 PSI	4 PSI	5 PSI	6 PSI	7 PSI	8 PSI	9 PSI	10 PSI
B209	0.8	1/2"	0.8	1.1	1.4	1.6	1.8	2.0	2.1	2.3	2.4	2.5
B210	1.2		1.2	1.7	2.1	2.4	2.8	2.9	3.2	3.4	3.6	3.8
B211	1.9		1.9	2.7	3.3	3.8	4.2	4.7	5.0	5.4	5.7	6.0
B212	3.0		3.0	4.2	5.2	6.0	6.8	7.3	7.9	8.5	9.0	9.5
B213	4.7		4.7	6.6	8.1	9.4	11	12	12	13	14	15
B214	7.4		7.4	10	13	15	17	18	20	21	22	23

## 2-Way Modulating Valve (Steam) - 1/2"



Two-way modulating control valves for MicroTech are designed to regulate the flow of steam. They consist of a nickel plated brass body and stainless steel ball valve and stem, with a spring return, proportional actuator. The optional valve accessory is shipped separate from the unit ventilator for field installation to prevent shipping damage and to provide flexibility in making the field piping connection.

**Table 12: 2-Way Actuator Specifications (Steam)**

Power Supply	24 VAC ± 20%, 50/60 Hz, 24 VDC ± 10%
Power Consumption Running	2 W
Power Consumption Holding	1 W
Transformer Sizing	4 VA (class 2 power source)
Electrical Connection	3ft [1m], 18 GA plenum cable with 1/2" conduit connector"
Overload Protection	electronic throughout 0° to 95° rotation
Operating Range Y	2 to 10 VDC, 4 to 20 mA w/ ZG-R01 (500 Ω, 1/4 W resistor)
Input Impedance	100 k Ω for 2 to 10 VDC (0.1 mA), 500 Ω for 4 to 20 mA
Feedback Output U	2 to 10 VDC, 0.5 mA max
Angle of Rotation	Max. 95°, 90°
Direction of Rotation (Motor)	reversible with built-in switch
Direction of Rotation (Fail-Safe)	reversible with CW/CCW mounting
Position Indication	visual indicator, 0° to 95° (0° is full spring return position)
Running Time (Motor)	95 sec
Running Time (Fail-Safe)	<25 sec
Ambient Humidity	max. 95% RH non-condensing
Ambient Temperature Range	-22°F to 122°F [-30°C to 50°C]
Storage Temperature Range	-40°F to 176°F [-40°C to 80°C]
Housing	NEMA 2, IP42, UL enclosure type 2
Housing Material	UL94-5VA
Agency Listings <sup>1</sup>	cULus acc. to UL60730-1A/-2-14, CAN/CSA E60730-1:02, CE acc. to 2004/108/EC and 2006/95/EC
Noise Level (Motor)	<35 dB (A)
Noise Level (Fail-Safe)	<62 dB (A)
Servicing	maintenance free
Quality Standard	ISO 9001

**Note:** <sup>1</sup> Rated Impulse Voltage 800V, Type of action 1.AA, Control Pollution Degree 3

**Table 13: Valve Body Specifications (Steam)**

Service	high temperature hot water/low pressure steam, up to 60% glycol
Flow Characteristic	A-port equal percentage
Controllable Flow Range	75°
Size [mm]	0.5" [15]
End Fitting	NPT female ends
Body	nickel plated brass (DZR) P-CuZn35Pb2
Ball	stainless steel
Stem	stainless steel
Stem Packing	Viton O-ring
Seat	ETFE
Seat O-ring	EPDM (lubricated)
Characterized Disc	ETFE
Body Pressure Rating [psi]	600
Max Inlet Pressure (Steam)	15 psi
Media Temperature Range (Water)	60°F to 266°F [16°C to 130°C]
Media Temperature Range (Steam)	250°F [120°C]
Maximum Differential Pressure (Steam)	15 psi
Max Differential Pressure (Water)	60 psi partially open ball, 116 psi full open
Close-Off Pressure	200 psi
Leakage	0%
Servicing	maintenance free

## 2-Way Modulating Steam Valve Specifications

### Modulating Steam Valve Selection

The steam modulating control valve is expected to vary the quantity of steam through the coil. Any movement of the valve stem should produce some change in the steam flow rate. To select a modulating steam valve:

1. Obtain the supply steam inlet pressure.
2. Determine the actual heat requirement of the space to be heated.

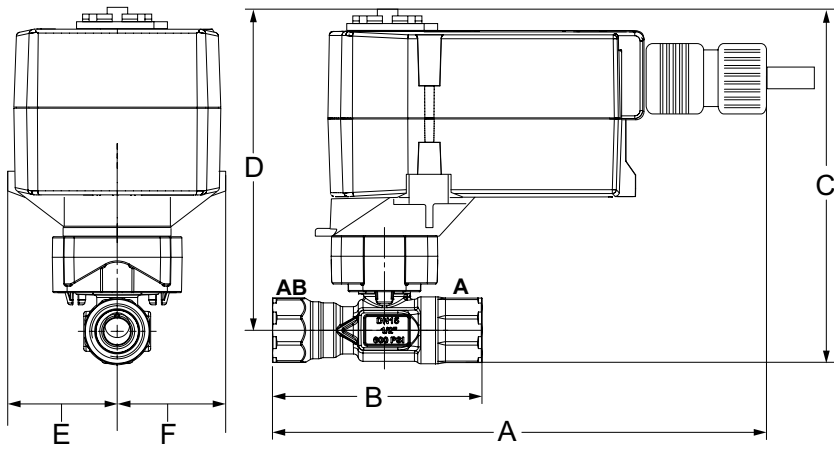

**Table 14: 2-Way Modulating Steam Valve 1/2" – Dimensions**

Valve Part No.	Cv	Connection Size (inches)	A	B	C	D	E	F	Weight	
									Valve Body	Actuator
B215HT073	0.73	1/2"	7.32" (186mm)	3.33" (85mm)	5.8" (147mm)	5.3" (135mm)	1.52" (39mm)	1.52" (38.5mm)	0.7 lb [0.3 kg]	1.8 lb [0.8 kg]
B215HT186	1.86									
B215HT455	4.55									

**Note:** See "Table 12: 2-Way Actuator Specifications (Steam)" on page 36" and "Table 13: Valve Body Specifications (Steam)" on page 36.

**Table 15: 2-Way Modulating Steam Valve 1/2" – Pressure Drop**

2-Way CCV Part No.	Cv Maximum Rating	Connection Size	Pressure Drop Across the Valve					
			2 PSI	3 PSI	4 PSI	5 PSI	10 PSI	15 PSI
B215HT073	0.73	1/2"	10.99	13.71	16.11	18.33	28.03	36.74
B215HT186	1.86		22.34	34.93	41.06	46.70	71.42	93.60
B215HT455	4.55		54.65	85.44	100.43	114.24	174.72	228.97

## 2-Way Modulating Valve (Steam) - 3/4"

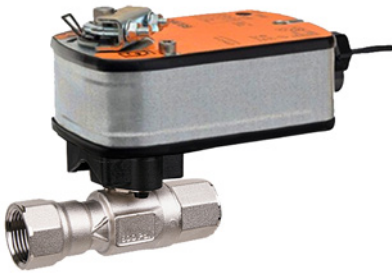

The modulating control valves for MicroTech are designed to regulate the flow of steam. They consist of a nickel plated brass body and stainless steel ball valve and stem, with a spring return, proportional actuator. The optional valve accessory is shipped separate from the unit ventilator for field installation to prevent shipping damage and to provide flexibility in making the field piping connection.

**Table 16: Actuator Specifications**

Power Supply	24 VAC ± 20%, 50/60 Hz, 24 VDC ± 10%
Power Consumption Running	2.5 W
Power Consumption Holding	1 W
Transformer Sizing	5 VA (class 2 power source)
Electrical Connection	3ft [1m], 18 GA plenum cable with 1/2" conduit connector
Overload Protection	electronic throughout 0° to 95° rotation
Operating Range Y	2 to 10 VDC, 4 to 20 mA w/ ZG-R01 (500 Ω, 1/4 W resistor)
Input Impedance	100 k Ω for 2 to 10 VDC (0.1 mA), 500 Ω for 4 to 20 mA
Feedback Output U	2 to 10 VDC (max 0.7 mA) for 95°
Angle of Rotation	90°
Direction of Rotation (Motor)	reversible with built-in switch
Direction of Rotation (Fail-Safe)	reversible with CW/CCW mounting
Position Indication	visual indicator, 0° to 95° (0° is full spring return position)
Running Time (Motor)	150 sec constant, independent of load
Running Time (Fail-Safe)	<25 sec @ -4°F to 122°F [-20°C to 50°C], < 60 sec @ -22°F [-30°C]"
Ambient Temperature Range	-22°F to 122°F [-30°C to 50°C]
Storage Temperature Range	-40°F to 176°F [-40°C to 80°C]
Housing	NEMA 2, IP54
Agency Listings <sup>1</sup>	cULus acc. To UL 873 and CAN/CSA C22.2 No. 24-93"
Noise Level (Motor)	<50 dB (A)
Noise Level (Fail-Safe)	<62 dB (A)
Servicing	maintenance free
Quality Standard	ISO 9001

**Note:** <sup>1</sup> Rated Impulse Voltage 800V, Type of action 1.AA, Control Pollution Degree 3

**Table 17: Valve Body Specifications**

Service	high temperature hot water/low pressure steam, up to 60% glycol
Flow Characteristic	A-port equal percentage
Controllable Flow Range	75°
Size [mm]	0.75" [20]
End Fitting	NPT female ends
Body	nickel plated brass (DZR) P-CuZn35Pb2
Ball	stainless steel
Stem	stainless steel
Stem Packing	Viton O-ring
Seat	ETFE
Seat O-ring	EPDM (lubricated)
Characterized Disc	ETFE
Body Pressure Rating [psi]	600
Max Inlet Pressure (Steam)	15 psi
Media Temperature Range (Water)	60°F to 266°F [16°C to 130°C]
Media Temperature Range (Steam)	250°F [120°C]
Maximum Differential Pressure (Steam)	15 psi
Max Differential Pressure (Water)	60 psi partially open ball, 116 psi full open
Close-Off Pressure	200 psi
Leakage	0%
Servicing	maintenance free

## 2-Way Modulating Steam Valve Specifications

### Modulating Steam Valve Selection

The steam modulating control valve is expected to vary the quantity of steam through the coil. Any movement of the valve stem should produce some change in the steam flow rate. To select a modulating steam valve:

1. Obtain the supply steam inlet pressure.
2. Determine the actual heat requirement of the space to be heated.

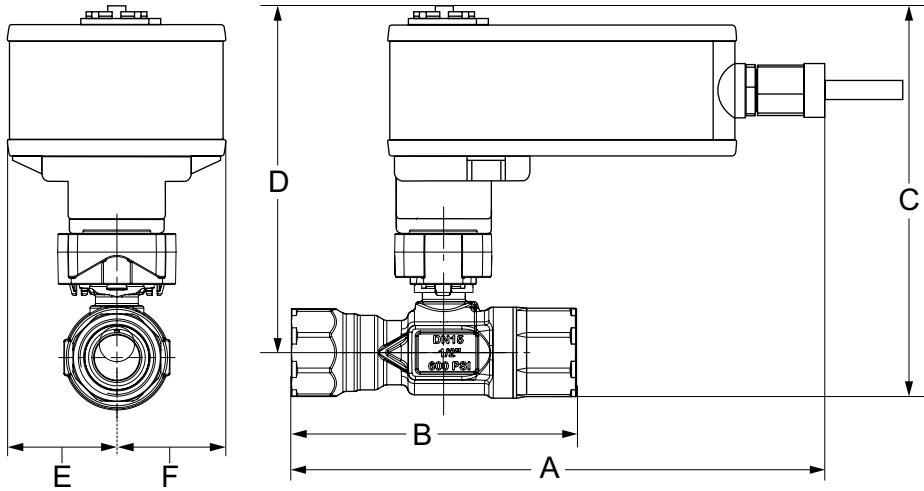

**Table 18: 2-Way Modulating Valve 3/4" – Dimensions**

Valve Part No.	Cv	Connection Size (inches)	A	B	C	D	E	F	Weight	
									Valve Body	Actuator
B220HT731	7.31	3/4 inch	8.70" (221mm)	3.96" (101mm)	6.74" (171mm)	6.07" (154mm)	1.89" (48mm)	1.89" (48mm)	0.9 lb. (0.4 kg)	1.8 lb. (0.8 kg)

**Note:** See "Table 16: Actuator Specifications" on page 38" and "Table 17: Valve Body Specifications" on page 38.

**Table 19: 2-Way Modulating Steam Valve 3/4" – Pressure Drop**

2-Way CCV Part No.	Cv Maximum Rating	Connection Size	Pressure Drop Across the Valve					
			2 PSI	3 PSI	4 PSI	5 PSI	10 PSI	15 PSI
B220HT731	7.31	3/4 inch	110.02	137.27	161.36	183.54	280.70	367.86

### 3-Way Modulating Hot Water Valve



Three-way modulating control valves for MicroTech are designed to regulate the flow of hot water. They consist of a nickel plated brass body and stem with chrome plated brass ball valve, with a spring return, proportional actuator. The optional valve accessory is shipped separate from the unit ventilator for field installation to prevent shipping damage and to provide flexibility in making the field piping connection.

**Table 20: 3-Way Actuator Specifications (HW)**

Power Supply	24 VAC, ±20%, 50/60 Hz, 24 VDC, ±10%
Power Consumption Running	2 W
Power Consumption Holding	1 W
Transformer Sizing	4 VA (class 2 power source)
Electrical Connection	3ft [1m], 18 GA plenum cable with 1/2" conduit connector
Overload Protection	electronic throughout 0° to 95° rotation
Operating Range Y	2 to 10 VDC, 4 to 20 mA w/ ZG-R01 (500 Ω, 1/4 W resistor)
Input Impedance	100 k Ω for 2 to 10 VDC (0.1 mA), 500 Ω for 4 to 20 mA
Feedback Output U	2 to 10 VDC, 0.5 mA max
Angle of Rotation	Max. 95°, 90°
Direction of Rotation (Motor)	reversible with built-in switch
Direction of Rotation (Fail-Safe)	reversible with CW/CCW mounting
Position Indication	visual indicator, 0° to 95° (0° is full spring return position)
Running Time (Motor)	95 sec
Running Time (Fail-Safe)	<25 sec
Ambient Humidity	max. 95% RH non-condensing
Ambient Temperature Range	-22°F to 122°F [-30°C to 50°C]
Storage Temperature Range	-40°F to 176°F [-40°C to 80°C]
Housing	NEMA 2, IP42, UL Enclosure Type 2
Housing Material	UL94-5VA
Agency Listings <sup>1</sup>	cULus acc. to UL60730-1A/-2-14, CAN/CSA E60730-1:02, CE acc. to 2004/108/EC and 2006/95/EC
Noise Level (Motor)	<35 dB (A)
Noise Level (Fail-Safe)	<62 dB (A)
Servicing	maintenance free
Quality Standard	ISO 9001

**Note:** <sup>1</sup> Rated Impulse Voltage 800V, Type of action 1.AA, Control Pollution Degree 3

**Table 21: 3-Way Valve Body Specifications (HW)**

Service	hot water, up to 60% glycol
Flow Characteristic	A-port Equal percentage; B-port modified linear for constant flow
Controllable Flow Range	75°
Size [mm]	0.5" [15]
End Fitting	npt female ends
Body	forged brass, nickel plated
Ball	chrome plated brass
Stem	nickel plated brass
Stem Packing	EPDM (lubricated)
Seat	Teflon® PTFE
Seat O-ring	EPDM (lubricated)
Characterized Disc	TEFZEL®
Body Pressure Rating [psi]	600
Media Temperature Range (Water)	0°F to 250°F [-18°C to 120°C]
Max Differential Pressure (Water)	50 psi (345 kPa)
Close-Off Pressure	200 psi
Leakage	0% for A to AB, <2.0% for B to AB
Servicing	maintenance free



### 3-Way Modulating Valve Specifications

#### Hot Water Modulating Valve Selection

The unit ventilator control valve is expected to be able to vary the quantity of water that flows through the coil in a modulating fashion. Any movement of the valve stem should produce some change in the amount of water that flows through the coil. Oversized control valves cannot do this. For example, assume that when the control valve is fully open, the pressure drop through the coil is twice as great as the drop through the valve.

In this case, the control valve must travel to approximately 50% closed before it can begin to have any influence on the water flow through the coil. The control system, no matter how sophisticated, cannot

overcome this. Oversized control valves can also result in “hunting” which will shorten the life of the valve and actuator and possibly damage the coil.

To correctly select the proper Hot Water Modulating Valve:

1. Determine the flow of water and the corresponding pressure drop through the coil.
2. Obtain the pressure difference between the supply and return mains.
3. Select a valve size (Cv) from [Table 23](#), on the basis of taking 50% of the available pressure difference (at design flow) between the supply and return mains at the valve location. The valve should have a pressure drop greater than that of the coil.

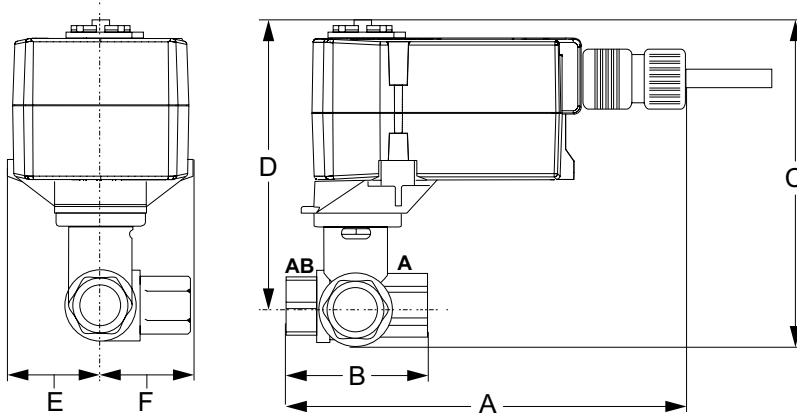

Figure 49: Formula Equation to Calculate Cv

Q = Capacity in gallons per minute

Cv = Valve sizing coefficient determined experimentally for each style and size of valve, using water at standard conditions as the test fluid

ΔP = Pressure differential in psi

G = Specific gravity of fluid (water at 60°F = 1.0000)

$$Cv = Q \sqrt{\frac{G}{\Delta P}}$$

Table 22: 3-Way Modulating Valve 1/2" – Dimensions

Valve Part No.	Cv	Connection Size (inches)	A	B	C	D	E	F	Weight	
									Valve Body	Actuator
B309(B)	0.8	1/2"	6.59" (167mm)	2.38" (60mm)	4.9" (124mm)	4.32" (110mm)	1.53" (38mm)	1.2" (31mm)	.07 lb. (.03 kg)	1.8 lb. (.08 kg)
B310(B)	1.2			2.38" (60mm)	4.9" (124mm)	4.71" (120mm)	1.53" (38mm)	1.29" (33mm)		
B311(B)	1.9									
B312(B)	3.0		6.59" (167mm)	2.73" (69mm)	5.5" (140mm)	4.8" (122mm)	1.53" (38mm)	1.47" (37mm)	.09 lb. (.04 kg)	
B313(B)	4.7			2.73" (69mm)	5.5" (140mm)	4.8" (122mm)	1.53" (38mm)	1.47" (37mm)		
B318(B)	7.4									

Note: See "Table 20: 3-Way Actuator Specifications (HW)" on page 40" and "Table 21: 3-Way Valve Body Specifications (HW)" on page 40.

Table 23: Modulating 3-Way Hot Water Valve 1/2" – Pressure Drop

2-Way CCV Part No.	Cv Maximum Rating	Connection Size	Pressure Drop Across the Valve									
			1 PSI	2 PSI	3 PSI	4 PSI	5 PSI	6 PSI	7 PSI	8 PSI	9 PSI	10 PSI
B309(B)	0.8	1/2"	0.8	1.	1.4	1.6	1.8	2.0	2.	2.3	2.4	2.5
B310(B)	1.2		1.2	1.7	2.	2.4	2.8	2.9	3.2	3.4	3.6	3.8
B311(B)	1.9		1.9	2.7	3.3	3.8	4.2	4.7	5.0	5.4	5.7	6.0
B312(B)	3.0		3.0	4.2	5.2	6.0	6.8	7.3	7.9	8.5	9.0	9.5
B313(B)	4.7		4.7	6.6	8.1	9.4	11	12	12	13	14	15
B318(B)	7.4		7.4	10	13	15	17	18	20	21	22	23

## Quick Selection Procedure

The following procedure will provide you with a rough determination of unit capacity for cooling and/or heating based on the number of coil rows. Use capacity tables for final selection. Consult your local Daikin representative for details on the computer selection programs Daikin Applied provides for this purpose.

**Table 24: Hot Water Heating Capacity Btuh**

Rows	60°F Entering Air Temperature; 160°F Entering Water Temperature; 6 GPM Water Flow		
	024	036	044, 054
1	49,500	57,000	66,000
2	62,000	74,100	97,200

**Table 25: Quick Selection Table**

Unit Size	Compressor Capacity	Fan Speed	Nominal Airflow	Cooling		Outdoor Temp.
				Total Capacity	Efficiency	
			CFM	Btuh	EER	DB / WB
024	Full	High	1000	20700	9.7	95 / 75
	Part	Med	750	16700	12.2	82 / 65
	Part	Low	650	16200	12.2	82 / 65
036	Full	High	1250	38100	10.6	95 / 75
	Part	Med	1000	29800	13.5	82 / 65
	Part	Low	800	28500	13.2	82 / 65
044	Full	High	1500	44900	10.4	95 / 75
	Part	Med	1050	35400	12.5	82 / 65
	Part	Low	850	33800	12.1	82 / 65
054	Full	High	1500	53500	10.4	95 / 75
	Part	Med	1050	40700	12.2	82 / 65
	Part	Low	850	38800	11.8	82 / 65

**Note:** Cooling Conditions: Indoor 80°F db/67°F wb (26.7°C/19.4°C)

## Selection Procedure

### Step 1: Determine Design Conditions

Determine design indoor and outdoor air temperatures in accordance with established engineering practices, as outlined in the ASHRAE Guide or other authoritative source. Indoor temperatures of 80°F dry bulb, 67°F wet bulb for summer and 70°F dry bulb for winter usually are acceptable for design or peak load conditions, even though the expected operating conditions of the system may be somewhat different.

### Step 2: Determine Heating and Cooling Loads

Calculate design winter heating losses and summer cooling loads in accordance with the procedures outlined by the ASHRAE Guide or other authoritative source. Perhaps the greatest consideration in calculating design loads is solar heat gain. August solar heat values might be used for summer cooling loads, but should not be used for ventilation air or “natural cooling” capacity calculations; since these cooling loads reach their maximum in the spring and autumn months. The natural cooling capacity is usually calculated for 55° or 60°F outdoor air temperature.

**Table 26: Outdoor Air Ventilation Sensible Cooling Capacities Based On 75°F Room Temperature**

Unit Series	Nominal CFM	Outdoor Air Temperature	
		55°F	60°F
024	1000	21.7 MBH	16.3 MBH
036	1250	27.1 MBH	20.3 MBH
044, 054	1500	32.6 MBH	24.4 MBH

### Step 3: Determine Air Quantity Required

Air quantity for heating applications is determined from circulation of a definite number of room air volumes per hour. Table 27 gives the recommended number of room air changes per hour.

**Table 27: Recommended Room Air Changes Per Hour**

Type of Space	Recommended Number of Room Air Changes Per Hour
Classrooms, Offices	6 to 9
Laboratories, Shops	6 to 8
Cafeterias & Kitchens	4½ to 7

For rooms facing east, south or west, the higher values shown in the table should be used so adequate ventilation cooling will be available to prevent overheating during mild sunny weather. The following equation is helpful to determine the CFM air delivery for any given rate of circulation:

### Equation 1: CFM For Given Rate Of Circulation

$$\frac{\text{Room Volume (cu ft)} \times \text{Room Changes per Hour}}{60} = \text{CFM}$$

In mechanical cooling applications, the total air quantity may be determined or verified by use of the sensible cooling load equation:

### Equation 2: CFM Based On Sensible Cooling Load

$$\text{CFM} = \frac{Q \text{ sensible (space)}}{1.086 \times \text{TD}}$$

Q sensible is the maximum sensible room load and T.D. is the temperature difference between the room design dry bulb temperature and the final or leaving-air dry bulb temperature. For these calculations, a T.D. of 20°F is usually assumed to be desirable to avoid delivering air too cold for comfort. This figure may be varied one or two degrees for reasons of practicality.

**Note:** The sensible load used in the preceding equation is the space load and excludes the ventilation load.

Most areas have ventilation codes which govern the amount of ventilation air required for school applications. For other than school applications or areas not having codes, the ASHRAE Guide may be used for authoritative recommendations and discussion of the relation between odor control and outdoor air quantities.

The minimum outdoor air quantity recommended by ASHRAE for K-12 classrooms is 10 CFM per person plus 0.12 CFM/ft<sup>2</sup>. Lower percent minimum outdoor air settings are more economical. In the interest of economy, it may be desirable to use lower percent minimums if there are no ventilation codes.

### Step 4: Select Unit Size

The unit should be selected to meet or exceed the CFM delivery requirement previously determined. All model types are available with nominal capacities of 1000, 1250 and 1500 CFM. Unit sizes 024, 036, 044 and 054.

## Cooling Capacity

Unit cooling capacity should be selected to equal or slightly exceed the sum of computed room sensible and latent heat gains (Room Total Capacity). When operating on the mechanical cooling cycle, the control system introduces a constant amount of outdoor air for ventilation. The latent and sensible heat gain from this outdoor ventilation air must be added to the room total cooling load before choosing the proper capacity unit.

## Heating Capacity

Unit heating capacity should be selected to equal or slightly exceed the computed room heat loss. For units installed for 100% recirculation, it is good practice to increase the heating capacity by 15% to aid in quick room warm-up. This allowance is unnecessary for units delivering a minimum outdoor air of 20% or more, since the outdoor air damper remains closed until the room is up to temperature. The heat normally expended in heating the minimum-percent outdoor air up to room temperature is available for quick warm-up purposes.

The heating required to warm the outdoor ventilating air up to room temperature must also be calculated. The Total Capacity should be used in sizing, piping, boilers, etc.

### Step 5: Freeze Protection

**Constant pump operation is required whenever the outdoor air temperature is below 35°F.** This will assist in providing protection against freeze up of the system water piping and coils. To reduce the possibility of water coil freeze up on valve-controlled units, the valve must be selected properly to provide adequate water flow. See "Application Considerations" on page 97. One of the steps below should be followed.

### Hot Water

Carry out one of the following steps to help protect against freezing:

- Use antifreeze in the system.
- Open the hot water coil valve and close the outdoor air damper whenever a freezing condition is sensed at the coil.

### Step 6: Units With Antifreeze

If ethylene glycol or propylene glycol is used, its effect upon heating capacities and its effect on water pressure drops through the coil and piping system must be considered, as follows:

1. Divide the heating loads determined in Step 2 by the applicable capacity correction factor shown in Table 28 or Table 29 to arrive at the calculated unit capacity required to take care of the capacity reduction caused by the glycol solution.

**Table 28: Capacity Correction Factors for Ethylene Glycol**

Ethylene Glycol% Weight	20%	30%	40%
Hot Water	0.94	0.90	0.84

**Table 29: Capacity Correction Factors for Propylene Glycol**

Propylene Glycol% Weight	20%	30%	40%
Hot Water	0.98	0.96	0.92

2. Determine the GPM required by entering the appropriate hot water capacity chart using the calculated unit capacity.
3. Determine the water pressure drop by multiplying the water pressure drop for the GPM determined above by the applicable pressure drop correction factor shown in Table 30 or Table 31 below.

**Table 30: Pressure Drop Correction Factors for Ethylene Glycol**

Ethylene Glycol% Weight	20%	30%	40%
Hot Water	1.08	1.11	1.19

**Table 31: Pressure Drop Correction Factors for Propylene Glycol**

Propylene Glycol% Weight	20%	30%	40%
Hot Water	1.07	1.11	1.15

## Cooling Selection Example

### Step 1: Determine Design Conditions

Assume the following design indoor and outdoor air temperatures are given:

- Outdoor design temperature = 96°F DB / 74°F WB
- Room design temperature = 76°F DB / 65°F WB

### Step 2: Determine Cooling Loads

Assume the following cooling loads are given:

- Minimum total capacity (TC) = 37.8 MBH
- Minimum sensible capacity (SC) = 23.9 MBH
- Minimum outdoor air = 20%
- Room volume = 9,000 cubic feet
- Desired number of air changes per hour = 8

### Step 3: Determine Air Quantity Required

"Equation 1: CFM For Given Rate Of Circulation" on page 43 indicates that to obtain eight room volumes per hour, a unit capable of delivering 1200 CFM standard air must be used, as follows:

$$CFM = \frac{(\text{Room Volume Ft}^3) \times (\text{Room Changes per Hour})}{60}$$

$$CFM = \frac{9000 \times 8}{60} = 1200$$

This indicates that a size 036 Unit Ventilator should be used, which delivers 1250 CFM.

### Step 4: Select Unit Size

Determine the unit performance as follows:

#### Determine Entering Dry Bulb Temperature

The entering dry bulb (EDB) temperature is calculated using the following formula:

$$\text{EDB} = \text{Room DB} \times \frac{\% \text{RA}}{100} + \text{Outdoor DB} \times \frac{\% \text{OA}}{100}$$

$$\text{EDB} = 76(0.8) + (96)(0.2) = 80^\circ\text{F}$$

#### Determine Entering Wet Bulb Temperature

The entering wet bulb (EWB) temperature is determined by calculating the Enthalpy (H) at saturation, then looking up the corresponding EWB ([Table 32 on page 46](#)). Enthalpy (H) is calculated as follows:

$$\text{Enthalpy (H)} = \text{Room Enthalpy} \times \frac{\% \text{RA}}{100} + \text{Outdoor Enthalpy} \times \frac{\% \text{OA}}{100}$$

$$\text{Enthalpy (H)} = 30.06 (0.8) + 37.66 (0.2) = 31.58 \text{ btu/lb}$$

Referring to [Table 32 on page 46](#), EWB for 31.58 btu/lb = 67°F

#### Look Up Capacities

Look up the Total and Sensible cooling capacity for a Size 036 unit at High Fan Speed from "[Size 036 \(1250 SCFM\) – 2nd Stage High Fan](#)" on page 52. Interpolation between the values for Outdoor DB = 90°F and 100°F, at Entering Air Temperature DB/WB = 80/67, will yield the following results.

- 38.3 MBH (TC)
- 24.9 MBH (SC)

Leaving air temperatures dry bulb °F (LDB) and wet bulb °F (LWB) may be calculated as follows:

$$\text{LDB} = \text{EDB} - \frac{\text{SC(Btuh)}}{\text{CFM} \times 1.085} = 80 - \frac{24900}{1250 \times 1.085} = 61.6^\circ\text{F}$$

$$\text{LWBH} = \text{EWBH} - \frac{\text{TC(Btuh)}}{\text{CFM} \times 4.5} = 31.62 - \frac{38320}{1250 \times 4.5} = 24.8$$

#### From [Table 32 on page 46](#):

LWB at 24.8 H = 57.5°F.

**Note:** Interpolation within each table and between sets of tables for each unit series is permissible.

For conditions of performance beyond the scope of the catalog selection procedures, Daikin offers computer selection programs for cooling, hot water and steam coils. Consult your local Daikin representative for details.

**Table 32: Enthalpy (H) at Saturation But Per Pound of Dry Air**

Wet Bulb Temp. °F	Tenths of A Degree									
	0	0.1	0.2	0.3	0.4	0.5	0.6	0.7	0.8	0.9
50	20.3	20.36	20.41	20.47	20.52	20.58	20.64	20.69	20.75	20.8
51	20.86	20.92	20.97	21.03	21.09	21.15	21.2	21.26	21.32	21.38
52	21.44	21.5	21.56	21.62	21.67	21.73	21.79	21.85	21.91	21.97
53	22.02	22.08	22.14	22.2	22.26	22.32	22.38	22.44	22.5	22.56
54	22.62	22.68	22.74	22.8	22.86	22.92	22.98	23.04	23.1	23.16
55	23.22	23.28	23.34	23.41	23.47	23.53	23.59	23.65	23.72	23.78
56	23.84	23.9	23.97	24.03	24.1	24.16	24.22	24.29	24.35	24.42
57	24.48	24.54	24.61	24.67	24.74	24.8	24.86	24.93	24.99	25.06
58	25.12	25.19	25.25	25.32	25.38	25.45	25.52	25.58	26.65	25.71
59	25.78	25.85	25.92	25.98	26.05	26.12	26.19	26.26	26.32	26.39
60	26.46	26.53	26.6	26.67	26.74	26.81	26.87	26.94	27.01	27.08
61	27.15	27.22	27.29	27.36	27.43	27.5	27.57	27.64	27.71	27.78
62	27.85	27.92	27.99	28.07	28.14	28.21	28.28	28.35	28.43	28.5
63	28.57	28.64	28.72	28.79	28.87	28.94	29.01	29.09	29.16	29.24
64	29.31	29.39	29.46	29.54	29.61	29.69	29.76	29.84	29.91	29.99
65	30.06	30.14	30.21	30.29	30.37	30.45	30.52	30.6	30.68	30.78
66	30.83	30.91	30.99	31.07	31.15	31.23	31.3	31.38	31.46	31.54
67	31.62	31.7	31.78	31.86	31.94	32.02	32.1	32.18	32.26	32.34
68	32.42	32.5	32.59	32.67	32.75	32.84	32.92	33	33.08	33.17
69	33.25	33.33	33.42	33.5	33.59	33.67	33.75	33.84	33.92	34.01
70	34.09	34.18	34.26	34.35	34.43	34.52	34.61	34.69	34.78	34.86
71	34.95	35.04	35.13	35.21	35.3	35.39	35.48	35.57	35.65	35.74
72	35.83	35.92	36.01	36.1	36.19	36.29	36.38	36.47	36.56	36.65
73	36.74	36.83	36.92	37.02	37.11	37.2	37.29	37.38	37.48	37.57
74	37.66	37.76	37.85	37.95	38.04	38.14	38.23	38.33	38.42	38.52
75	38.61	38.71	38.8	38.9	38.99	39.09	39.19	39.28	39.38	39.47
76	39.57	39.67	39.77	39.87	39.97	40.07	40.17	40.27	40.37	40.47
77	40.57	40.67	40.77	40.87	40.97	41.08	41.18	41.28	41.38	41.48
78	41.58	41.68	41.79	41.89	42	42.1	42.2	42.31	42.41	42.52
79	42.62	42.73	42.83	42.94	43.05	43.16	43.26	43.37	43.48	43.58
80	43.69	43.8	43.91	44.02	44.13	44.24	44.34	44.45	44.56	44.67
81	44.78	44.89	45	45.12	45.23	45.34	45.45	45.56	45.68	45.79
82	45.9	46.01	46.13	46.24	46.36	46.47	46.58	46.7	46.81	46.93
83	47.04	47.16	47.28	47.39	47.51	47.63	47.75	47.87	47.98	48.1
84	48.22	48.34	48.46	48.58	48.7	48.83	48.95	49.07	49.19	49.31
85	49.43	49.55	49.68	49.8	49.92	50.05	50.17	50.29	50.41	50.54

## Hot Water Heating Selection

For proper temperature control, do not oversize the heating coil. Select the hot water coil that just slightly exceeds the required heating capacity. Hot water coils are offered in two capacities. The low-capacity (65) coil and the high-capacity (66) coil can be used as heating only or in conjunction with direct-expansion cooling coil.

### Quick Selection Method Using MBH/ΔT

Once the unit size has been selected, the MBH/ΔT factor can be utilized to quickly and accurately determine coil size and minimum GPM, where:

$$\Delta T = \text{Entering Water Temp} - \text{Entering Air Temp}$$

For example, assume an entering water temperature of 180°F, an entering air temperature of 55°F and a total heating load of 75 MBH. Then,

$$\Delta T = 180 - 55 = 125 \text{ and, } \text{MBH}/\Delta T = 75/125 = 0.6$$

Assume we want to size for the 036 unit determined in the coil selection example previously given for cooling.

Referring to [Figure 50](#) or [Figure 51](#):

- 1 Enter each chart at MBH/ΔT = 0.6.
- 2 Move horizontally to the right to intersect the unit 036, 1250 scfm curve.
- 3 Project downward for GPM requirement.

It is quickly seen that the 1-row coil ([Figure 50](#)) does not meet the heating load. The 2-row coil ([Figure 51](#)) can meet the requirement with 3.4 GPM.

**Figure 50: 1-Row Hot Water Coil**

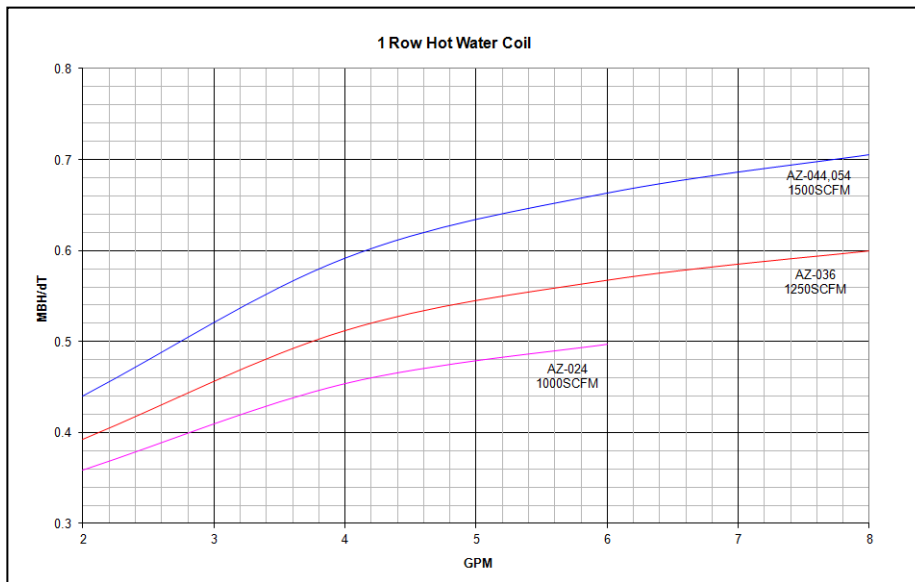

**Figure 51: 2-Row Hot Water Coil (Parallel Flow)**

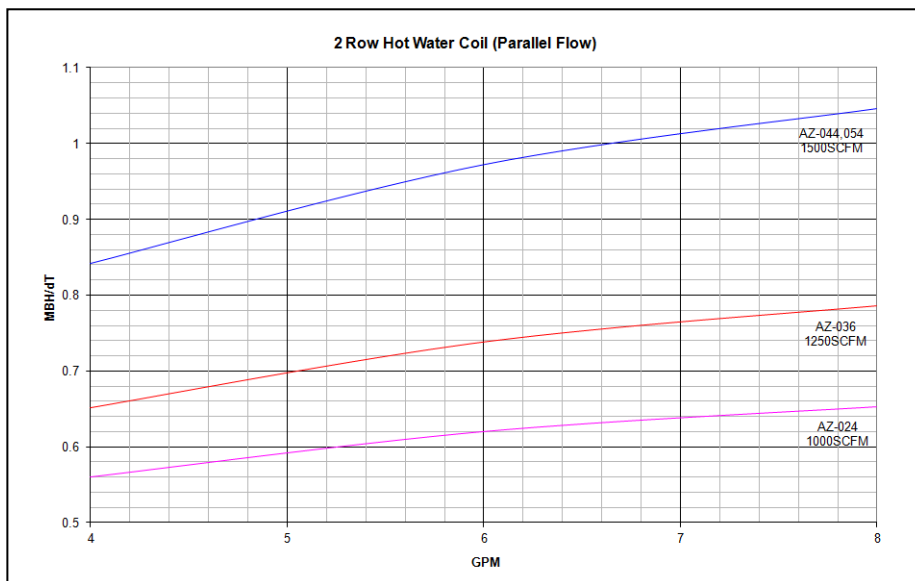

## Steam Heating Selection

The maximum allowable steam pressure, especially in public buildings, is often fixed by state or local boiler codes. Steam Capacity in Table 33 is based on steam supply pressure of 2 PSI gauge and steam temperature of 218.5°F.

To determine total capacity for conditions other than shown in the Steam Capacity Table 33, multiply the total capacity given by the proper constant from the Steam Capacity Correction Factor in Table 34.

Maximum steam pressure is 15 PSIG at coil inlet.

Traps are by others. Either float and thermostatic traps or thermostatic traps may be used.

Table 33: Steam Heating Capacities - 2# Steam Coils

Unit	Coil Capacity	Airflow SCFM	Entering Air Temperature °F																			
			-20		-10		0		10		20		30		40		50		60		70	
			MBH	LAT, db	MBH	LAT, db	MBH	LAT, db	MBH	LAT, db	MBH	LAT, db	MBH	LAT, db	MBH	LAT, db	MBH	LAT, db	MBH	LAT, db	MBH	LAT, db
1000	Std	1000	82.1	55.8	78.7	62.6	75.2	69.3	71.6	76.0	68.0	82.7	65.6	90.5	61.8	97.0	58.0	103.5	54.1	109.9	50.4	116.5
	High		98.3	70.6	94.1	76.8	89.9	82.9	85.6	89.0	81.3	95.0	77.0	101.0	72.3	106.7	67.7	112.4	63.0	118.1	58.4	123.9
1250	Std	1250	97.0	51.6	93.0	58.6	89.0	65.7	85.0	72.7	80.9	79.7	76.7	86.6	72.3	93.3	67.9	100.1	63.5	106.9	59.9	114.2
	High		122.6	70.4	117.6	76.7	112.5	83.0	107.3	89.2	102.1	95.3	96.8	101.4	91.2	107.3	85.6	113.2	80.0	119.0	74.4	124.9
1500	Std	1500	121.3	54.6	116.5	61.6	111.5	68.5	106.5	75.5	101.4	82.3	96.3	89.2	90.8	95.8	85.5	102.5	80.0	109.2	75.6	116.5
	High		140.0	66.0	134.3	72.5	128.5	79.0	123.6	86.0	117.7	92.4	111.8	98.7	105.5	104.8	99.2	111.0	92.8	117.1	86.6	123.2

Table 34: Steam Capacity Correction Factors

Steam Pressure PSIG	Entering Air Temperature Mixture, °F									
	-20	-10	0	10	20	30	40	50	60	70
0	0.97	0.97	0.97	0.96	0.97	0.97	0.97	0.96	0.96	0.96
2	1.00	1.00	1.00	1.00	1.00	1.00	1.00	1.00	1.00	1.00
5	1.02	1.03	1.03	1.03	1.04	1.05	1.05	1.05	1.05	1.05

## Electric Heating Selection

Table 35: Electric Heat Capacities

Unit Type	AZQ, AZU, AZR							
	CFM		1250 (036)		1500 (044, 054)			
	Number of Electric Elements		3	6	3	6		
<b>208 Volt Units</b>								
kW			8.0	16.0	10.0	20.0	12.0	24.0
MBH			27.3	54.6	34.1	68.3	41.0	81.9
Final Air Temp F (70°F entering air temp)			95.2	120.3	95.2	120.3	95.2	120.3
Air Temperature Rise			25.2	50.3	25.2	50.3	25.2	50.3
<b>230, 265 or 460 Volt Units</b>								
kW			7.4	14.7	9.2	18.4	11.0	22.0
MBH			25.3	50.2	31.4	62.8	37.5	75.1
Final Air Temp F (70°F entering air temp)			93.2	116.2	93.2	116.2	93.2	116.2
Air Temperature Rise			23.2	46.2	23.2	46.2	23.2	46.2



## Size 024 (1000 SCFM) – 2nd Stage High Fan

Entering Air Temperature Outdoor DB °F	Entering Air Temperature Indoor DB/WB °F	Cooling				Entering Air Temperature Outdoor DB °F	Entering Air Temperature Indoor DB/WB °F	Cooling			
		Total Btuh	Sensible Btuh	Power Input kW	EER			Total Btuh	Sensible Btuh	Power Input kW	EER
40	65/55	19,900	15,700	1.352	14.7	90	65/55	16,900	13,300	1.965	8.6
	70/59	21,400	16,700	1.372	15.6		70/59	18,500	14,200	1.985	9.3
	75/63	23,000	17,700	1.392	16.5		75/63	20,000	15,200	2.005	10.0
	80/67	24,500	18,700	1.412	17.4		80/67	21,500	16,200	2.025	10.6
	85/71	26,000	19,700	1.432	18.2		85/71	23,100	17,200	2.045	11.3
50	65/55	20,100	15,500	1.423	14.1	100	65/55	15,100	12,400	2.164	7.0
	70/59	21,600	16,500	1.443	15.0		70/59	16,700	13,400	2.184	7.6
	75/63	23,200	17,500	1.464	15.8		75/63	18,200	14,400	2.204	8.3
	80/67	24,700	18,500	1.484	16.6		80/67	19,800	15,400	2.224	8.9
	85/71	26,200	19,400	1.504	17.4		85/71	21,300	16,300	2.244	9.5
60	65/55	19,900	15,100	1.520	13.1	110	65/55	13,000	11,400	2.388	5.4
	70/59	21,400	16,100	1.541	13.9		70/59	14,500	12,400	2.409	6.0
	75/63	23,000	17,100	1.561	14.7		75/63	16,000	13,400	2.429	6.6
	80/67	24,500	18,100	1.581	15.5		80/67	17,600	14,400	2.449	7.2
	85/71	26,000	19,100	1.601	16.2		85/71	19,100	15,400	2.469	7.7
70	65/55	19,300	14,600	1.643	11.7	115	65/55	11,700	10,900	2.510	4.7
	70/59	20,800	15,600	1.663	12.5		70/59	13,300	11,800	2.530	5.3
	75/63	22,400	16,600	1.683	13.3		75/63	14,800	12,800	2.551	5.8
	80/67	23,900	17,600	1.703	14.0		80/67	16,300	13,800	2.571	6.3
	85/71	25,500	18,600	1.724	14.8		85/71	17,900	14,800	2.591	6.9
80	65/55	18,300	14,000	1.791	10.2						
	70/59	19,800	15,000	1.811	10.9						
	75/63	21,400	16,000	1.831	11.7						
	80/67	22,900	17,000	1.852	12.4						
	85/71	24,500	17,900	1.872	13.1						

**Note:** Capacity Data at Full Load

**Legend:** Btuh = British Thermal Units per Hour

EER = Energy Efficiency Ratio

kW = Kilowatt

DB = Dry Bulb

WB = Wet Bulb

## Size 024 (750 SCFM) – 1st Stage Medium Fan

Entering Air Temperature Outdoor DB °F	Entering Air Temperature Indoor DB/WB °F	Cooling				Entering Air Temperature Outdoor DB °F	Entering Air Temperature Indoor DB/WB °F	Cooling			
		Total Btu/hr	Sensible Btu/hr	Power Input kW	EER			Total Btu/hr	Sensible Btu/hr	Power Input kW	EER
40	65/55	19,100	11,700	0.955	20.0	90	65/55	12,000	9,600	1.524	7.9
	70/59	20,200	12,600	0.942	21.4		70/59	13,200	10,400	1.511	8.7
	75/63	21,400	13,400	0.929	23.0		75/63	14,400	11,200	1.499	9.6
	80/67	22,600	14,200	0.917	24.6		80/67	15,500	12,000	1.486	10.4
	85/71	23,700	15,000	0.904	26.2		85/71	16,700	12,800	1.474	11.3
50	65/55	17,700	11,400	1.032	17.2	100	65/55	10,600	9,000	1.692	6.3
	70/59	18,900	12,200	1.020	18.5		70/59	11,700	9,800	1.680	7.0
	75/63	20,000	13,000	1.007	19.9		75/63	12,900	10,600	1.667	7.7
	80/67	21,200	13,800	0.995	21.3		80/67	14,100	11,400	1.655	8.5
	85/71	22,400	14,600	0.982	22.8		85/71	15,200	12,200	1.642	9.3
60	65/55	16,300	11,000	1.128	14.5	110	65/55	9,100	8,400	1.879	4.8
	70/59	17,500	11,800	1.115	15.7		70/59	10,200	9,200	1.866	5.5
	75/63	18,700	12,600	1.103	17.0		75/63	11,400	10,000	1.854	6.1
	80/67	19,800	13,400	1.090	18.2		80/67	12,600	10,800	1.841	6.8
	85/71	21,000	14,200	1.078	19.5		85/71	13,700	11,600	1.829	7.5
70	65/55	14,900	10,600	1.242	12.0	115	65/55	8,300	8,000	1.979	4.2
	70/59	16,100	11,400	1.229	13.1		70/59	9,500	8,900	1.966	4.8
	75/63	17,200	12,200	1.217	14.1		75/63	10,600	9,700	1.954	5.4
	80/67	18,400	13,000	1.204	15.3		80/67	11,800	10,500	1.941	6.1
	85/71	19,600	13,800	1.192	16.4		85/71	13,000	11,300	1.929	6.7
80	65/55	13,500	10,100	1.374	9.8						
	70/59	14,700	10,900	1.361	10.8						
	75/63	15,800	11,700	1.349	11.7						
	80/67	17,000	12,500	1.336	12.7						
	85/71	18,200	13,300	1.324	13.7						

**Note:** Capacity Data at Full Load

**Legend:** Btuh = British Thermal Units per Hour

EER = Energy Efficiency Ratio

kW = Kilowatt

DB = Dry Bulb

WB = Wet Bulb

## Size 024 (650 SCFM) – 1st Stage Low Fan

Entering Air Temperature Outdoor DB °F	Entering Air Temperature Indoor DB/WB °F	Cooling				Entering Air Temperature Outdoor DB °F	Entering Air Temperature Indoor DB/WB °F	Cooling			
		Total Btu/hr	Sensible Btu/hr	Power Input kW	EER			Total Btu/hr	Sensible Btu/hr	Power Input kW	EER
40	65/55	18,500	10,900	0.928	19.9	90	65/55	11,700	8,900	1.482	7.9
	70/59	19,600	11,600	0.916	21.4		70/59	12,800	9,600	1.470	8.7
	75/63	20,800	12,400	0.904	23.0		75/63	13,900	10,400	1.457	9.5
	80/67	21,900	13,100	0.891	24.6		80/67	15,100	11,100	1.445	10.4
	85/71	23,000	13,900	0.879	26.2		85/71	16,200	11,900	1.433	11.3
50	65/55	17,200	10,600	1.004	17.1	100	65/55	10,200	8,300	1.645	6.2
	70/59	18,300	11,300	0.991	18.5		70/59	11,400	9,100	1.633	7.0
	75/63	19,400	12,100	0.979	19.8		75/63	12,500	9,800	1.621	7.7
	80/67	20,600	12,800	0.967	21.3		80/67	13,600	10,600	1.609	8.5
	85/71	21,700	13,600	0.955	22.7		85/71	14,800	11,300	1.597	9.3
60	65/55	15,800	10,200	1.097	14.4	110	65/55	8,800	7,800	1.827	4.8
	70/59	17,000	11,000	1.084	15.7		70/59	9,900	8,500	1.815	5.5
	75/63	18,100	11,700	1.072	16.9		75/63	11,100	9,300	1.802	6.2
	80/67	19,200	12,400	1.060	18.1		80/67	12,200	10,000	1.790	6.8
	85/71	20,400	13,200	1.048	19.5		85/71	13,300	10,800	1.778	7.5
70	65/55	14,500	9,800	1.207	12.0	115	65/55	8,100	7,500	1.924	4.2
	70/59	15,600	10,500	1.195	13.1		70/59	9,200	8,200	1.912	4.8
	75/63	16,700	11,300	1.183	14.1		75/63	10,300	9,000	1.900	5.4
	80/67	17,900	12,000	1.171	15.3		80/67	11,500	9,700	1.887	6.1
	85/71	19,000	12,800	1.159	16.4		85/71	12,600	10,500	1.875	6.7
80	65/55	13,100	9,300	1.336	9.8						
	70/59	14,200	10,100	1.324	10.7						
	75/63	15,300	10,800	1.311	11.7						
	80/67	16,500	11,600	1.299	12.7						
	85/71	17,600	12,300	1.287	13.7						

**Note:** Capacity Data at Full Load

**Legend:** Btuh = British Thermal Units per Hour

EER = Energy Efficiency Ratio

kW = Kilowatt

DB = Dry Bulb

WB = Wet Bulb

## Size 036 (1250 SCFM) – 2nd Stage High Fan

Entering Air Temperature Outdoor DB °F	Entering Air Temperature Indoor DB/WB °F	Cooling				Entering Air Temperature Outdoor DB °F	Entering Air Temperature Indoor DB/WB °F	Cooling			
		Total Btu/hr	Sensible Btu/hr	Power Input kW	EER			Total Btu/hr	Sensible Btu/hr	Power Input kW	EER
40	65/55	38,400	26,700	2.099	18.3	90	65/55	26,300	20,900	3.656	7.2
	70/59	42,600	28,200	2.034	20.9		70/59	30,600	22,400	3.591	8.5
	75/63	46,900	29,600	1.969	23.8		75/63	34,900	23,900	3.526	9.9
	80/67	51,200	31,100	1.904	26.9		80/67	39,200	25,300	3.461	11.3
	85/71	55,500	32,500	1.839	30.2		85/71	43,500	26,800	3.396	12.8
50	65/55	35,800	25,500	2.430	14.7	100	65/55	24,200	19,900	3.938	6.1
	70/59	40,100	26,900	2.365	17.0		70/59	28,500	21,300	3.873	7.4
	75/63	44,300	28,400	2.300	19.3		75/63	32,800	22,800	3.808	8.6
	80/67	48,600	29,900	2.235	21.7		80/67	37,000	24,300	3.743	9.9
	85/71	52,900	31,300	2.170	24.4		85/71	41,300	25,700	3.678	11.2
60	65/55	33,300	24,300	2.751	12.1	110	65/55	22,100	18,800	4.210	5.2
	70/59	37,600	25,800	2.686	14.0		70/59	26,400	20,300	4.145	6.4
	75/63	41,800	27,200	2.622	15.9		75/63	30,700	21,800	4.080	7.5
	80/67	46,100	28,700	2.557	18.0		80/67	35,000	23,200	4.015	8.7
	85/71	50,400	30,200	2.492	20.2		85/71	39,300	24,700	3.950	9.9
70	65/55	30,900	23,200	3.063	10.1	115	65/55	21,100	18,300	4.342	4.9
	70/59	35,200	24,600	2.998	11.7		70/59	25,400	19,800	4.277	5.9
	75/63	39,400	26,100	2.933	13.4		75/63	29,700	21,300	4.212	7.1
	80/67	43,700	27,600	2.868	15.2		80/67	34,000	22,700	4.147	8.2
	85/71	48,000	29,000	2.803	17.1		85/71	38,300	24,200	4.083	9.4
80	65/55	28,500	22,000	3.364	8.5						
	70/59	32,800	23,500	3.300	9.9						
	75/63	37,100	25,000	3.235	11.5						
	80/67	41,400	26,400	3.170	13.1						
	85/71	45,700	27,900	3.105	14.7						

**Note:** Capacity Data at Full Load

**Legend:** Btuh = British Thermal Units per Hour

EER = Energy Efficiency Ratio

kW = Kilowatt

DB = Dry Bulb

WB = Wet Bulb

## Size 036 (1000 SCFM) – 1st Stage Medium Fan

Entering Air Temperature Outdoor DB °F	Entering Air Temperature Indoor DB/WB °F	Cooling				Entering Air Temperature Outdoor DB °F	Entering Air Temperature Indoor DB/WB °F	Cooling			
		Total Btu/hr	Sensible Btu/hr	Power Input kW	EER			Total Btu/hr	Sensible Btu/hr	Power Input kW	EER
40	65/55	27,100	17,400	1.542	17.6	90	65/55	21,100	15,600	2.460	8.6
	70/59	29,400	18,300	1.528	19.2		70/59	23,400	16,500	2.447	9.6
	75/63	31,800	19,200	1.514	21.0		75/63	25,800	17,500	2.433	10.6
	80/67	34,200	20,100	1.500	22.8		80/67	28,200	18,400	2.419	11.7
	85/71	36,600	21,100	1.487	24.6		85/71	30,600	19,300	2.406	12.7
50	65/55	26,600	17,400	1.647	16.2	100	65/55	18,700	14,700	2.762	6.8
	70/59	29,000	18,300	1.633	17.8		70/59	21,100	15,600	2.748	7.7
	75/63	31,400	19,300	1.619	19.4		75/63	23,500	16,500	2.735	8.6
	80/67	33,800	20,200	1.606	21.0		80/67	25,900	17,500	2.721	9.5
	85/71	36,100	21,100	1.592	22.7		85/71	28,200	18,400	2.707	10.4
60	65/55	25,800	17,300	1.791	14.4	110	65/55	16,000	13,500	3.103	5.2
	70/59	28,200	18,200	1.778	15.9		70/59	18,400	14,500	3.089	6.0
	75/63	30,600	19,100	1.764	17.3		75/63	20,800	15,400	3.075	6.8
	80/67	32,900	20,000	1.750	18.8		80/67	23,100	16,300	3.062	7.5
	85/71	35,300	21,000	1.736	20.3		85/71	25,500	17,200	3.048	8.4
70	65/55	24,600	16,900	1.975	12.5	115	65/55	14,500	12,900	3.288	4.4
	70/59	27,000	17,800	1.961	13.8		70/59	16,900	13,800	3.274	5.2
	75/63	29,400	18,800	1.948	15.1		75/63	19,300	14,800	3.261	5.9
	80/67	31,700	19,700	1.934	16.4		80/67	21,600	15,700	3.247	6.7
	85/71	34,100	20,600	1.920	17.8		85/71	24,000	16,600	3.233	7.4
80	65/55	23,000	16,400	2.198	10.5						
	70/59	25,400	17,300	2.184	11.6						
	75/63	27,800	18,200	2.171	12.8						
	80/67	30,200	19,100	2.157	14.0						
	85/71	32,500	20,100	2.143	15.2						

**Note:** Capacity Data at Full Load

**Legend:** Btuh = British Thermal Units per Hour

EER = Energy Efficiency Ratio

kW = Kilowatt

DB = Dry Bulb

WB = Wet Bulb

## Size 036 (800 SCFM) – 1st Stage Low Fan

Entering Air Temperature Outdoor DB °F	Entering Air Temperature Indoor DB/WB °F	Cooling				Entering Air Temperature Outdoor DB °F	Entering Air Temperature Indoor DB/WB °F	Cooling			
		Total Btu/hr	Sensible Btu/hr	Power Input kW	EER			Total Btu/hr	Sensible Btu/hr	Power Input kW	EER
40	65/55	25,900	15,800	1.505	17.2	90	65/55	20,100	14,200	2.402	8.4
	70/59	28,200	16,700	1.491	18.9		70/59	22,400	15,100	2.388	9.4
	75/63	30,400	17,500	1.478	20.6		75/63	24,700	15,900	2.375	10.4
	80/67	32,700	18,300	1.464	22.3		80/67	27,000	16,700	2.361	11.4
	85/71	35,000	19,200	1.451	24.1		85/71	29,200	17,600	2.348	12.4
50	65/55	25,500	15,900	1.607	15.9	100	65/55	17,900	13,400	2.696	6.6
	70/59	27,700	16,700	1.594	17.4		70/59	20,200	14,200	2.683	7.5
	75/63	30,000	17,500	1.581	19.0		75/63	22,500	15,000	2.669	8.4
	80/67	32,300	18,400	1.567	20.6		80/67	24,700	15,900	2.656	9.3
	85/71	34,600	19,200	1.554	22.3		85/71	27,000	16,700	2.642	10.2
60	65/55	24,700	15,700	1.748	14.1	110	65/55	15,300	12,300	3.029	5.1
	70/59	27,000	16,600	1.735	15.6		70/59	17,600	13,200	3.015	5.8
	75/63	29,200	17,400	1.722	17.0		75/63	19,900	14,000	3.002	6.6
	80/67	31,500	18,200	1.708	18.4		80/67	22,100	14,900	2.989	7.4
	85/71	33,800	19,100	1.695	19.9		85/71	24,400	15,700	2.975	8.2
70	65/55	23,500	15,400	1.928	12.2	115	65/55	13,900	11,800	3.210	4.3
	70/59	25,800	16,200	1.914	13.5		70/59	16,100	12,600	3.196	5.0
	75/63	28,100	17,100	1.901	14.8		75/63	18,400	13,400	3.183	5.8
	80/67	30,400	17,900	1.888	16.1		80/67	20,700	14,300	3.169	6.5
	85/71	32,600	18,800	1.874	17.4		85/71	23,000	15,100	3.156	7.3
80	65/55	22,000	14,900	2.146	10.3						
	70/59	24,300	15,700	2.132	11.4						
	75/63	26,600	16,600	2.119	12.6						
	80/67	28,800	17,400	2.105	13.7						
	85/71	31,100	18,300	2.092	14.9						

**Note:** Capacity Data at Full Load

**Legend:** Btuh = British Thermal Units per Hour

EER = Energy Efficiency Ratio

kW = Kilowatt

DB = Dry Bulb

WB = Wet Bulb

## Size 044 (1500 SCFM) – 2nd Stage High Fan

Entering Air Temperature Outdoor DB °F	Entering Air Temperature Indoor DB/WB °F	Cooling				Entering Air Temperature Outdoor DB °F	Entering Air Temperature Indoor DB/WB °F	Cooling			
		Total Btu/hr	Sensible Btu/hr	Power Input kW	EER			Total Btu/hr	Sensible Btu/hr	Power Input kW	EER
40	65/55	45,100	33,400	2.905	15.5	90	65/55	35,200	27,400	4.043	8.7
	70/59	48,900	34,600	2.937	16.6		70/59	39,000	28,600	4.076	9.6
	75/63	52,700	35,800	2.969	17.8		75/63	42,700	29,800	4.108	10.4
	80/67	56,400	36,900	3.002	18.8		80/67	46,500	31,000	4.141	11.2
	85/71	60,200	38,100	3.034	19.8		85/71	50,300	32,100	4.173	12.1
50	65/55	44,000	32,300	3.048	14.4	100	65/55	31,900	26,100	4.398	7.3
	70/59	47,800	33,500	3.080	15.5		70/59	35,700	27,300	4.430	8.1
	75/63	51,600	34,700	3.113	16.6		75/63	39,400	28,500	4.463	8.8
	80/67	55,300	35,800	3.145	17.6		80/67	43,200	29,600	4.495	9.6
	85/71	59,100	37,000	3.178	18.6		85/71	46,900	30,800	4.528	10.4
60	65/55	42,500	31,200	3.234	13.1	110	65/55	28,100	24,700	4.794	5.9
	70/59	46,300	32,300	3.266	14.2		70/59	31,900	25,900	4.827	6.6
	75/63	50,000	33,500	3.298	15.2		75/63	35,700	27,100	4.859	7.3
	80/67	53,800	34,700	3.331	16.2		80/67	39,400	28,200	4.892	8.1
	85/71	57,500	35,900	3.363	17.1		85/71	43,200	29,400	4.924	8.8
70	65/55	40,500	30,000	3.461	11.7	115	65/55	26,100	24,000	5.009	5.2
	70/59	44,300	31,100	3.494	12.7		70/59	29,800	25,200	5.041	5.9
	75/63	48,000	32,300	3.526	13.6		75/63	33,600	26,400	5.073	6.6
	80/67	51,800	33,500	3.559	14.6		80/67	37,400	27,500	5.106	7.3
	85/71	55,600	34,700	3.591	15.5		85/71	41,100	28,700	5.138	8.0
80	65/55	38,100	28,700	3.731	10.2						
	70/59	41,900	29,900	3.764	11.1						
	75/63	45,600	31,100	3.796	12.0						
	80/67	49,400	32,200	3.829	12.9						
	85/71	53,100	33,400	3.861	13.8						

**Note:** Capacity Data at Full Load

**Legend:** Btuh = British Thermal Units per Hour

EER = Energy Efficiency Ratio

kW = Kilowatt

DB = Dry Bulb

WB = Wet Bulb

## Size 044 (1050 SCFM) – 1st Stage Medium Fan

Entering Air Temperature Outdoor DB °F	Entering Air Temperature Indoor DB/WB °F	Cooling				Entering Air Temperature Outdoor DB °F	Entering Air Temperature Indoor DB/WB °F	Cooling			
		Total Btu/hr	Sensible Btu/hr	Power Input kW	EER			Total Btu/hr	Sensible Btu/hr	Power Input kW	EER
40	65/55	33,100	22,500	2.164	15.3	90	65/55	26,300	19,200	3.130	8.4
	70/59	35,600	23,400	2.139	16.6		70/59	28,800	20,100	3.104	9.3
	75/63	38,100	24,300	2.113	18.0		75/63	31,200	21,000	3.078	10.1
	80/67	40,500	25,200	2.088	19.4		80/67	33,700	21,900	3.053	11.0
	85/71	43,000	26,100	2.062	20.9		85/71	36,100	22,800	3.027	11.9
50	65/55	32,500	22,200	2.276	14.3	100	65/55	23,800	18,200	3.446	6.9
	70/59	35,000	23,100	2.250	15.6		70/59	26,300	19,100	3.420	7.7
	75/63	37,400	24,000	2.224	16.8		75/63	28,700	20,000	3.394	8.5
	80/67	39,900	24,900	2.199	18.1		80/67	31,200	20,900	3.369	9.3
	85/71	42,400	25,800	2.173	19.5		85/71	33,600	21,800	3.343	10.1
60	65/55	31,500	21,600	2.428	13.0	110	65/55	20,900	16,900	3.802	5.5
	70/59	34,000	22,500	2.402	14.2		70/59	23,400	17,800	3.777	6.2
	75/63	36,400	23,400	2.377	15.3		75/63	25,800	18,700	3.751	6.9
	80/67	38,900	24,300	2.351	16.5		80/67	28,300	19,600	3.725	7.6
	85/71	41,400	25,200	2.325	17.8		85/71	30,800	20,500	3.700	8.3
70	65/55	30,200	21,000	2.621	11.5	115	65/55	19,400	16,300	3.996	4.9
	70/59	32,600	21,900	2.595	12.6		70/59	21,800	17,200	3.970	5.5
	75/63	35,100	22,800	2.570	13.7		75/63	24,300	18,100	3.945	6.2
	80/67	37,500	23,700	2.544	14.7		80/67	26,700	19,000	3.919	6.8
	85/71	40,000	24,600	2.518	15.9		85/71	29,200	19,900	3.894	7.5
80	65/55	28,400	20,200	2.855	9.9						
	70/59	30,900	21,100	2.829	10.9						
	75/63	33,300	22,000	2.804	11.9						
	80/67	35,800	22,900	2.778	12.9						
	85/71	38,300	23,800	2.752	13.9						

**Note:** Capacity Data at Full Load

**Legend:** Btuh = British Thermal Units per Hour  
 EER = Energy Efficiency Ratio  
 kW = Kilowatt

DB = Dry Bulb  
 WB = Wet Bulb



## Size 044 (850 SCFM) – 1st Stage Low Fan

Entering Air Temperature Outdoor DB °F	Entering Air Temperature Indoor DB/WB °F	Cooling				Entering Air Temperature Outdoor DB °F	Entering Air Temperature Indoor DB/WB °F	Cooling			
		Total Btu/hr	Sensible Btu/hr	Power Input kW	EER			Total Btu/hr	Sensible Btu/hr	Power Input kW	EER
40	65/55	31,600	20,600	2.132	14.8	90	65/55	25,100	17,500	3.082	8.1
	70/59	34,000	21,400	2.106	16.1		70/59	27,500	18,400	3.057	9.0
	75/63	36,300	22,200	2.081	17.4		75/63	29,800	19,200	3.032	9.8
	80/67	38,700	23,000	2.056	18.8		80/67	32,200	20,000	3.007	10.7
	85/71	41,000	23,800	2.031	20.2		85/71	34,500	20,800	2.981	11.6
50	65/55	31,100	20,200	2.241	13.9	100	65/55	22,700	16,600	3.393	6.7
	70/59	33,400	21,000	2.216	15.1		70/59	25,100	17,400	3.368	7.5
	75/63	35,700	21,900	2.191	16.3		75/63	27,400	18,200	3.343	8.2
	80/67	38,100	22,700	2.165	17.6		80/67	29,800	19,000	3.318	9.0
	85/71	40,400	23,500	2.140	18.9		85/71	32,100	19,800	3.292	9.8
60	65/55	30,100	19,700	2.391	12.6	110	65/55	20,000	15,400	3.745	5.3
	70/59	32,500	20,600	2.366	13.7		70/59	22,300	16,300	3.719	6.0
	75/63	34,800	21,400	2.341	14.9		75/63	24,700	17,100	3.694	6.7
	80/67	37,100	22,200	2.315	16.0		80/67	27,000	17,900	3.669	7.4
	85/71	39,500	23,000	2.290	17.2		85/71	29,400	18,700	3.644	8.1
70	65/55	28,800	19,100	2.581	11.2	115	65/55	18,500	14,800	3.935	4.7
	70/59	31,100	20,000	2.556	12.2		70/59	20,800	15,700	3.910	5.3
	75/63	33,500	20,800	2.531	13.2		75/63	23,200	16,500	3.885	6.0
	80/67	35,800	21,600	2.505	14.3		80/67	25,500	17,300	3.860	6.6
	85/71	38,200	22,400	2.480	15.4		85/71	27,900	18,100	3.834	7.3
80	65/55	27,100	18,400	2.812	9.6						
	70/59	29,500	19,200	2.786	10.6						
	75/63	31,800	20,000	2.761	11.5						
	80/67	34,200	20,900	2.736	12.5						
	85/71	36,500	21,700	2.711	13.5						

**Note:** Capacity Data at Full Load

**Legend:** Btuh = British Thermal Units per Hour

EER = Energy Efficiency Ratio

kW = Kilowatt

DB = Dry Bulb

WB = Wet Bulb

## Size 054 (1500 SCFM) – 2nd Stage High Fan

Entering Air Temperature Outdoor DB °F	Entering Air Temperature Indoor DB/WB °F	Cooling				Entering Air Temperature Outdoor DB °F	Entering Air Temperature Indoor DB/WB °F	Cooling			
		Total Btu/hr	Sensible Btu/hr	Power Input kW	EER			Total Btu/hr	Sensible Btu/hr	Power Input kW	EER
40	65/55	53,300	37,100	3.361	15.9	90	65/55	43,300	30,900	4.769	9.1
	70/59	57,300	38,300	3.409	16.8		70/59	47,300	32,100	4.817	9.8
	75/63	61,200	39,600	3.458	17.7		75/63	51,200	33,400	4.866	10.5
	80/67	65,200	40,800	3.506	18.6		80/67	55,200	34,600	4.914	11.2
	85/71	69,200	42,100	3.555	19.5		85/71	59,200	35,900	4.962	11.9
50	65/55	52,300	36,000	3.533	14.8	100	65/55	39,800	29,400	5.215	7.6
	70/59	56,300	37,300	3.581	15.7		70/59	43,700	30,600	5.264	8.3
	75/63	60,300	38,500	3.629	16.6		75/63	47,700	31,900	5.312	9.0
	80/67	64,200	39,800	3.678	17.5		80/67	51,700	33,100	5.361	9.6
	85/71	68,200	41,000	3.726	18.3		85/71	55,600	34,400	5.409	10.3
60	65/55	50,900	34,900	3.759	13.5	110	65/55	35,700	27,800	5.717	6.2
	70/59	54,800	36,100	3.807	14.4		70/59	39,700	29,000	5.765	6.9
	75/63	58,800	37,400	3.856	15.2		75/63	43,600	30,300	5.814	7.5
	80/67	62,800	38,600	3.904	16.1		80/67	47,600	31,500	5.862	8.1
	85/71	66,700	39,900	3.953	16.9		85/71	51,600	32,800	5.911	8.7
70	65/55	48,900	33,600	4.041	12.1	115	65/55	33,500	27,000	5.988	5.6
	70/59	52,800	34,900	4.089	12.9		70/59	37,500	28,200	6.037	6.2
	75/63	56,800	36,100	4.137	13.7		75/63	41,400	29,500	6.085	6.8
	80/67	60,800	37,400	4.186	14.5		80/67	45,400	30,700	6.134	7.4
	85/71	64,700	38,600	4.234	15.3		85/71	49,300	31,900	6.182	8.0
80	65/55	46,300	32,300	4.377	10.6						
	70/59	50,300	33,600	4.426	11.4						
	75/63	54,300	34,800	4.474	12.1						
	80/67	58,200	36,100	4.522	12.9						
	85/71	62,200	37,300	4.571	13.6						

**Note:** Capacity Data at Full Load

**Legend:** Btuh = British Thermal Units per Hour

EER = Energy Efficiency Ratio

kW = Kilowatt

DB = Dry Bulb

WB = Wet Bulb

## Size 054 (1050 SCFM) – 1st Stage Medium Fan

Entering Air Temperature Outdoor DB °F	Entering Air Temperature Indoor DB/WB °F	Cooling				Entering Air Temperature Outdoor DB °F	Entering Air Temperature Indoor DB/WB °F	Cooling			
		Total Btu/hr	Sensible Btu/hr	Power Input kW	EER			Total Btu/hr	Sensible Btu/hr	Power Input kW	EER
40	65/55	42,700	25,000	2.440	17.5	90	65/55	30,400	21,400	3.673	8.3
	70/59	45,400	25,900	2.419	18.8		70/59	33,100	22,300	3.652	9.1
	75/63	48,100	26,800	2.398	20.1		75/63	35,800	23,200	3.631	9.9
	80/67	50,800	27,700	2.378	21.4		80/67	38,500	24,100	3.610	10.7
	85/71	53,500	28,600	2.357	22.7		85/71	41,100	25,000	3.590	11.4
50	65/55	40,600	24,600	2.590	15.7	100	65/55	27,400	20,200	4.064	6.7
	70/59	43,300	25,500	2.569	16.9		70/59	30,100	21,100	4.043	7.4
	75/63	46,000	26,400	2.548	18.1		75/63	32,800	22,000	4.023	8.2
	80/67	48,700	27,300	2.527	19.3		80/67	35,500	22,900	4.002	8.9
	85/71	51,300	28,200	2.507	20.5		85/71	38,200	23,800	3.981	9.6
60	65/55	38,300	24,100	2.788	13.7	110	65/55	24,300	18,800	4.504	5.4
	70/59	41,000	25,000	2.767	14.8		70/59	27,000	19,700	4.483	6.0
	75/63	43,700	25,900	2.746	15.9		75/63	29,700	20,600	4.463	6.7
	80/67	46,300	26,800	2.726	17.0		80/67	32,400	21,500	4.442	7.3
	85/71	49,000	27,700	2.705	18.1		85/71	35,100	22,400	4.421	7.9
70	65/55	35,800	23,400	3.035	11.8	115	65/55	22,700	18,000	4.742	4.8
	70/59	38,500	24,300	3.014	12.8		70/59	25,400	18,900	4.721	5.4
	75/63	41,200	25,200	2.993	13.8		75/63	28,100	19,800	4.701	6.0
	80/67	43,900	26,100	2.972	14.8		80/67	30,800	20,700	4.680	6.6
	85/71	46,600	27,000	2.951	15.8		85/71	33,400	21,600	4.659	7.2
80	65/55	33,200	22,500	3.330	10.0						
	70/59	35,900	23,400	3.309	10.8						
	75/63	38,600	24,300	3.288	11.7						
	80/67	41,200	25,200	3.267	12.6						
	85/71	43,900	26,100	3.246	13.5						

**Note:** Capacity Data at Full Load

**Legend:** Btuh = British Thermal Units per Hour

EER = Energy Efficiency Ratio

kW = Kilowatt

DB = Dry Bulb

WB = Wet Bulb

## Size 054 (850 SCFM) – 1st Stage Low Fan

Entering Air Temperature Outdoor DB °F	Entering Air Temperature Indoor DB/WB °F	Cooling				Entering Air Temperature Outdoor DB °F	Entering Air Temperature Indoor DB/WB °F	Cooling			
		Total Btu/hr	Sensible Btu/hr	Power Input kW	EER			Total Btu/hr	Sensible Btu/hr	Power Input kW	EER
40	65/55	40,700	22,900	2.407	16.9	90	65/55	29,000	19,600	3.623	8.0
	70/59	43,300	23,700	2.386	18.1		70/59	31,500	20,500	3.602	8.7
	75/63	45,900	24,500	2.366	19.4		75/63	34,100	21,300	3.582	9.5
	80/67	48,400	25,300	2.345	20.6		80/67	36,700	22,100	3.561	10.3
	85/71	51,000	26,200	2.325	21.9		85/71	39,200	22,900	3.541	11.1
50	65/55	38,700	22,500	2.555	15.1	100	65/55	26,100	18,500	4.009	6.5
	70/59	41,300	23,400	2.534	16.3		70/59	28,700	19,300	3.988	7.2
	75/63	43,800	24,200	2.514	17.4		75/63	31,300	20,200	3.968	7.9
	80/67	46,400	25,000	2.493	18.6		80/67	33,800	21,000	3.947	8.6
	85/71	48,900	25,800	2.473	19.8		85/71	36,400	21,800	3.927	9.3
60	65/55	36,500	22,100	2.750	13.3	110	65/55	23,200	17,200	4.443	5.2
	70/59	39,100	22,900	2.730	14.3		70/59	25,700	18,000	4.422	5.8
	75/63	41,600	23,700	2.709	15.4		75/63	28,300	18,900	4.402	6.4
	80/67	44,200	24,500	2.689	16.4		80/67	30,900	19,700	4.381	7.1
	85/71	46,700	25,400	2.668	17.5		85/71	33,400	20,500	4.361	7.7
70	65/55	34,100	21,400	2.993	11.4	115	65/55	21,600	16,500	4.678	4.6
	70/59	36,700	22,200	2.973	12.3		70/59	24,200	17,300	4.657	5.2
	75/63	39,300	23,100	2.952	13.3		75/63	26,800	18,100	4.637	5.8
	80/67	41,800	23,900	2.932	14.3		80/67	29,300	19,000	4.616	6.3
	85/71	44,400	24,700	2.911	15.3		85/71	31,900	19,800	4.596	6.9
80	65/55	31,600	20,600	3.284	9.6						
	70/59	34,200	21,400	3.264	10.5						
	75/63	36,800	22,300	3.243	11.3						
	80/67	39,300	23,100	3.223	12.2						
	85/71	41,900	23,900	3.202	13.1						

**Note:** Capacity Data at Full Load

**Legend:** Btuh = British Thermal Units per Hour  
 EER = Energy Efficiency Ratio  
 kW = Kilowatt

DB = Dry Bulb  
 WB = Wet Bulb

## AZU & AZQ – Size 024

Volt/Hz/Phase	Voltage Range		Room Fan FLA	Outdoor Fan FLA	Compressor		Heating Option				Power Supply	
	Min.	Max.			RLA	LRA	Heat Type		Heater kW	Rated Heater Amps	MCA	Maximum Fuse
208/60/1	197	228	3.2	2.8	11.7	58.3	None, HW Steam		–	–	20.63	30
			3.2	2.8	11.7	58.3	Elec. Heat <sup>1</sup> (AZU Only)	Low (3 elem.)	8.0	38.5	52.13	60
			3.2	2.8	11.7	58.3		High (6 elem.)	16.0	76.9	100.13	110
230/60/1	207	253	3.2	2.8	11.7	58.3	None, HW Steam		–	–	20.63	30
			3.2	2.8	11.7	58.3	Elec. Heat <sup>1</sup> (AZU Only)	Low (3 elem.)	7.3	33.3	45.63	50
			3.2	2.8	11.7	58.3		High (6 elem.)	14.7	66.7	87.38	90
208/60/3	197	228	3.2	2.8	6.5	55.4	None, HW Steam		–	–	14.13	20
			3.2	2.8	6.5	55.4	Elec. Heat <sup>1</sup> (AZU Only)	Low (3 elem.)	8.0	22.2	31.75	35
			3.2	2.8	6.5	55.4		High (6 elem.)	16.0	44.4	59.50	60
230/60/3	207	253	3.2	2.8	6.5	55.4	None, HW Steam		–	–	14.13	20
			3.2	2.8	6.5	55.4	Elec. Heat <sup>1</sup> (AZU Only)	Low (3 elem.)	7.3	19.2	28.00	30
			3.2	2.8	6.5	55.4		High (6 elem.)	14.7	38.5	52.13	60
460/60/3	414	506	3.2	1.5	3.5	28.0	None, HW Steam		–	–	9.08	15
			3.2	1.5	3.5	28.0	Elec. Heat <sup>1</sup> (AZU Only)	Low (3 elem.)	7.3	9.6	16.00	20
			3.2	1.5	3.5	28.0		High (6 elem.)	14.7	19.2	28.00	30

<sup>1</sup> Electric Heat Options are without Compressor and Outdoor Fan.

## AZR – Size 024

Volt/Hz/Phase	Voltage Range		Room Fan FLA	Outdoor Fan FLA	Compressor		Heating Option				Power Supply	
	Min.	Max.			RLA	LRA	Heat Type		Heater kW	Rated Heater Amps	MCA	Maximum Fuse
208/60/1	197	228	3.2	2.8	11.7	58.3	None, HW Steam		–	–	20.63	30
			3.2	2.8	11.7	58.3	Elec. Heat <sup>1</sup>	Low (3 elem.)	8.0	38.5	70.25	80
			3.2	2.8	11.7	58.3		High (6 elem.)	16.0	76.9	118.25	125
230/60/1	207	253	3.2	2.8	11.7	58.3	None, HW Steam		–	–	20.63	30
			3.2	2.8	11.7	58.3	Elec. Heat <sup>1</sup>	Low (3 elem.)	7.3	33.3	63.75	70
			3.2	2.8	11.7	58.3		High (6 elem.)	14.7	66.7	105.50	110
208/60/3	197	228	3.2	2.8	6.5	55.4	None, HW Steam		–	–	14.13	20
			3.2	2.8	6.5	55.4	Elec. Heat <sup>1</sup>	Low (3 elem.)	8.0	22.2	43.38	45
			3.2	2.8	6.5	55.4		High (6 elem.)	16.0	44.4	71.13	80
230/60/3	207	257	3.2	2.8	6.5	55.4	None, HW Steam		–	–	14.13	20
			3.2	2.8	6.5	55.4	Elec. Heat <sup>1</sup>	Low (3 elem.)	7.3	19.2	39.63	40
			3.2	2.8	6.5	55.4		High (6 elem.)	14.7	38.5	63.75	70
460/60/3	414	506	3.2	1.5	3.5	28.0	None, HW Steam		–	–	9.08	15
			3.2	1.5	3.5	28.0	Elec. Heat <sup>1</sup>	Low (3 elem.)	7.3	9.6	22.25	25
			3.2	1.5	3.5	28.0		High (6 elem.)	14.7	19.2	34.25	35

<sup>1</sup> Electric Heat Options are with Compressor and Outdoor Fan.

FLA = Full Load Amps

RLA = Rated Load Amps

LRA = Locked Rotor Amps

MCA = Minimum Circuit Ampacity

## AZU & AZQ – Size 036

Volt/Hz/Phase	Voltage Range		Room Fan FLA	Outdoor Fan FLA	Compressor		Heating Option			Power Supply		
	Min.	Max.			RLA	LRA	Heat Type		Heater kW	Rated Heater Amps	MCA	Maximum Fuse
208/60/1	197	228	3.2	2.8	17.9	96.0	None, HW Steam		–	–	28.38	45
			3.2	2.8	17.9	96.0	Elec. Heat <sup>1</sup> (AZU Only)	Low (3 elem.)	10.0	48.1	64.13	70
			3.2	2.8	17.9	96.0		High (6 elem.)	20.0	96.2	124.25	125
230/60/1	207	253	3.2	2.8	17.9	96.0	None, HW Steam		–	–	28.38	45
			3.2	2.8	17.9	96.0	Elec. Heat <sup>1</sup> (AZU Only)	Low (3 elem.)	9.2	41.7	56.13	60
			3.2	2.8	17.9	96.0		High (6 elem.)	18.4	83.3	108.13	110
208/60/3	197	228	3.2	2.8	14.2	88.0	None, HW Steam		–	–	23.75	35
			3.2	2.8	14.2	88.0	Elec. Heat <sup>1</sup> (AZU Only)	Low (3 elem.)	10.0	27.8	38.75	40
			3.2	2.8	14.2	88.0		High (6 elem.)	20.0	55.5	73.38	80
230/60/3	207	253	3.2	2.8	14.2	88.0	None, HW Steam		–	–	23.75	35
			3.2	2.8	14.2	88.0	Elec. Heat <sup>1</sup> (AZU Only)	Low (3 elem.)	9.2	24.1	34.13	35
			3.2	2.8	14.2	88.0		High (6 elem.)	18.4	48.1	64.13	70
460/60/3	414	506	3.2	1.5	6.2	44.0	None, HW Steam		–	–	12.45	15
			3.2	1.5	6.2	44.0	Elec. Heat <sup>1</sup> (AZU Only)	Low (3 elem.)	9.2	12.0	19.00	20
			3.2	1.5	6.2	44.0		High (6 elem.)	18.4	24.1	34.13	35

<sup>1</sup> Electric Heat Options are without Compressor and Outdoor Fan.

## AZR – Size 036

Volt/Hz/Phase	Voltage Range		Room Fan FLA	Outdoor Fan FLA	Compressor		Heating Option			Power Supply		
	Min.	Max.			RLA	LRA	Heat Type		Heater kW	Rated Heater Amps	MCA	Maximum Fuse
208/60/1	197	228	3.2	2.8	17.9	96.0	None, HW Steam		–	–	28.38	45
			3.2	2.8	17.9	96.0	Elec. Heat <sup>1</sup>	Low (3 elem.)	10.0	48.1	90.00	100
			3.2	2.8	17.9	96.0		High (6 elem.)	20.0	96.2	150.13	175
230/60/1	207	253	3.2	2.8	17.9	96.0	None, HW Steam		–	–	28.38	45
			3.2	2.8	17.9	96.0	Elec. Heat <sup>1</sup>	Low (3 elem.)	9.2	41.7	82.00	90
			3.2	2.8	17.9	96.0		High (6 elem.)	18.4	83.3	134.00	150
208/60/3	197	228	3.2	2.8	14.2	88.0	None, HW Steam		–	–	23.75	35
			3.2	2.8	14.2	88.0	Elec. Heat <sup>1</sup>	Low (3 elem.)	10.0	27.8	60.00	70
			3.2	2.8	14.2	88.0		High (6 elem.)	20.0	55.5	94.63	100
230/60/3	207	257	3.2	2.8	14.2	88.0	None, HW Steam		–	–	23.75	35
			3.2	2.8	14.2	88.0	Elec. Heat <sup>1</sup>	Low (3 elem.)	9.2	24.1	55.38	60
			3.2	2.8	14.2	88.0		High (6 elem.)	18.4	48.1	85.38	90
460/60/3	414	506	3.2	1.5	6.2	44.0	None, HW Steam		–	–	12.45	15
			3.2	1.5	6.2	44.0	Elec. Heat <sup>1</sup>	Low (3 elem.)	9.2	12.0	28.63	30
			3.2	1.5	6.2	44.0		High (6 elem.)	18.4	24.1	43.75	45

<sup>1</sup> Electric Heat Options are with Compressor and Outdoor Fan.

FLA = Full Load Amps

RLA = Rated Load Amps

LRA = Locked Rotor Amps

MCA = Minimum Circuit Ampacity

## AZU & AZQ – Size 044

Volt/Hz/Phase	Voltage Range		Room Fan FLA	Outdoor Fan FLA	Compressor		Heating Option			Power Supply		
	Min.	Max.			RLA	LRA	Heat Type		Heater kW	Rated Heater Amps	MCA	Maximum Fuse
208/60/1	197	228	3.2	6.8	21.2	104.0	None, HW Steam		–	–	36.50	50
			3.2	6.8	21.2	104.0	Elec. Heat <sup>1</sup> (AZU Only)	Low (3 elem.)	12.0	57.7	76.13	80
			3.2	6.8	21.2	104.0		High (6 elem.)	24.0	115.4	148.25	150
230/60/1	207	253	3.2	6.8	21.2	104.0	None, HW Steam		–	–	36.50	50
			3.2	6.8	21.2	104.0	Elec. Heat <sup>1</sup> (AZU Only)	Low (3 elem.)	11.0	50.0	66.50	70
			3.2	6.8	21.2	104.0		High (6 elem.)	22.0	100.0	129.00	150
208/60/3	197	228	3.2	6.8	14.0	83.1	None, HW Steam		–	–	27.50	40
			3.2	6.8	14.0	83.1	Elec. Heat <sup>1</sup> (AZU Only)	Low (3 elem.)	12.0	33.3	45.63	50
			3.2	6.8	14.0	83.1		High (6 elem.)	24.0	66.6	87.25	90
230/60/3	207	253	3.2	6.8	14.0	83.1	None, HW Steam		–	–	27.50	40
			3.2	6.8	14.0	83.1	Elec. Heat <sup>1</sup> (AZU Only)	Low (3 elem.)	11.0	28.9	40.13	45
			3.2	6.8	14.0	83.1		High (6 elem.)	22.0	57.7	76.13	80
460/60/3	414	506	3.2	2.2	6.4	41.0	None, HW Steam		–	–	13.40	15
			3.2	2.2	6.4	41.0	Elec. Heat <sup>1</sup> (AZU Only)	Low (3 elem.)	11.0	14.4	22.00	25
			3.2	2.2	6.4	41.0		High (6 elem.)	22.0	28.9	40.13	45

<sup>1</sup> Electric Heat Options are without Compressor and Outdoor Fan.

## AZR – Size 044

Volt/Hz/Phase	Voltage Range		Room Fan FLA	Outdoor Fan FLA	Compressor		Heating Option			Power Supply		
	Min.	Max.			RLA	LRA	Heat Type		Heater kW	Rated Heater Amps	MCA	Maximum Fuse
208/60/1	197	228	3.2	6.8	21.2	104.0	None, HW Steam		–	–	36.50	50
			3.2	6.8	21.2	104.0	Elec. Heat <sup>1</sup>	Low (3 elem.)	12.0	57.7	111.13	125
			3.2	6.8	21.2	104.0		High (6 elem.)	24.0	115.4	183.25	200
230/60/1	207	253	3.2	6.8	21.2	104.0	None, HW Steam		–	–	36.50	50
			3.2	6.8	21.2	104.0	Elec. Heat <sup>1</sup>	Low (3 elem.)	11.0	50	101.50	110
			3.2	6.8	21.2	104.0		High (6 elem.)	22.0	100	164.00	175
208/60/3	197	228	3.2	6.8	14.0	83.1	None, HW Steam		–	–	27.50	40
			3.2	6.8	14.0	83.1	Elec. Heat <sup>1</sup>	Low (3 elem.)	12.0	33.3	71.63	80
			3.2	6.8	14.0	83.1		High (6 elem.)	24.0	66.6	113.25	125
230/60/3	207	257	3.2	6.8	14.0	83.1	None, HW Steam		–	–	27.50	40
			3.2	6.8	14.0	83.1	Elec. Heat <sup>1</sup>	Low (3 elem.)	11.0	28.9	66.13	70
			3.2	6.8	14.0	83.1		High (6 elem.)	22.0	57.7	102.13	110
460/60/3	414	506	3.2	2.2	6.4	41.0	None, HW Steam		–	–	13.40	15
			3.2	2.2	6.4	41.0	Elec. Heat <sup>1</sup>	Low (3 elem.)	11.0	14.4	32.75	35
			3.2	2.2	6.4	41.0		High (6 elem.)	22.0	28.9	50.88	60

<sup>1</sup> Electric Heat Options are with Compressor and Outdoor Fan.

FLA = Full Load Amps

RLA = Rated Load Amps

LRA = Locked Rotor Amps

MCA = Minimum Circuit Ampacity

## AZU & AZQ – Size 054

Volt/Hz/Phase	Voltage Range		Room Fan FLA	Outdoor Fan FLA	Compressor		Heating Option			Power Supply		
	Min.	Max.			RLA	LRA	Heat Type		Heater kW	Rated Heater Amps	MCA	Maximum Fuse
208/60/1	197	228	3.2	6.8	27.1	152.9	None, HW Steam		–	–	43.88	70
			3.2	6.8	27.1	152.9	Elec. Heat <sup>1</sup> (AZU Only)	Low (3 elem.)	12.0	57.7	76.13	80
			3.2	6.8	27.1	152.9		High (6 elem.)	24.0	115.4	148.25	150
230/60/1	207	253	3.2	6.8	27.1	152.9	None, HW Steam		–	–	43.88	70
			3.2	6.8	27.1	152.9	Elec. Heat <sup>1</sup> (AZU Only)	Low (3 elem.)	11.0	50.0	66.50	70
			3.2	6.8	27.1	152.9		High (6 elem.)	22.0	100.0	129.00	150
208/60/3	197	228	3.2	6.8	16.5	110.0	None, HW Steam		–	–	30.63	45
			3.2	6.8	16.5	110.0	Elec. Heat <sup>1</sup> (AZU Only)	Low (3 elem.)	12.0	33.3	45.63	50
			3.2	6.8	16.5	110.0		High (6 elem.)	24.0	66.6	87.25	90
230/60/3	207	253	3.2	6.8	16.5	110.0	None, HW Steam		–	–	30.63	45
			3.2	6.8	16.5	110.0	Elec. Heat <sup>1</sup> (AZU Only)	Low (3 elem.)	11.0	28.9	40.13	45
			3.2	6.8	16.5	110.0		High (6 elem.)	22.0	57.7	76.13	80
460/60/3	414	506	3.2	2.2	7.2	52.0	None, HW Steam		–	–	14.40	20
			3.2	2.2	7.2	52.0	Elec. Heat <sup>1</sup> (AZU Only)	Low (3 elem.)	11.0	14.4	22.00	25
			3.2	2.2	7.2	52.0		High (6 elem.)	22.0	28.9	40.13	45

<sup>1</sup> Electric Heat Options are without Compressor and Outdoor Fan.

## AZR – Size 054

Volt/Hz/Phase	Voltage Range		Room Fan FLA	Outdoor Fan FLA	Compressor		Heating Option			Power Supply		
	Min.	Max.			RLA	LRA	Heat Type		Heater kW	Rated Heater Amps	MCA	Maximum Fuse
208/60/1	197	228	3.2	6.8	27.1	152.9	None, HW Steam		–	–	43.88	70
			3.2	6.8	27.1	152.9	Elec. Heat <sup>1</sup>	Low (3 elem.)	12.0	57.7	118.50	125
			3.2	6.8	27.1	152.9		High (6 elem.)	24.0	115.4	190.63	200
230/60/1	207	253	3.2	6.8	27.1	152.9	None, HW Steam		–	–	43.88	70
			3.2	6.8	27.1	152.9	Elec. Heat <sup>1</sup>	Low (3 elem.)	11.0	50	108.88	110
			3.2	6.8	27.1	152.9		High (6 elem.)	22.0	100	171.38	175
208/60/3	197	228	3.2	6.8	16.5	110.0	None, HW Steam		–	–	30.63	45
			3.2	6.8	16.5	110.0	Elec. Heat <sup>1</sup>	Low (3 elem.)	12.0	33.3	74.75	80
			3.2	6.8	16.5	110.0		High (6 elem.)	24.0	66.6	116.38	125
230/60/3	207	257	3.2	6.8	16.5	110.0	None, HW Steam		–	–	30.63	45
			3.2	6.8	16.5	110.0	Elec. Heat <sup>1</sup>	Low (3 elem.)	11.0	28.9	69.25	70
			3.2	6.8	16.5	110.0		High (6 elem.)	22.0	57.7	105.25	110
460/60/3	414	506	3.2	2.2	7.2	52.0	None, HW Steam		–	–	14.40	20
			3.2	2.2	7.2	52.0	Elec. Heat <sup>1</sup>	Low (3 elem.)	11.0	14.4	33.75	35
			3.2	2.2	7.2	52.0		High (6 elem.)	22.0	28.9	51.88	60

<sup>1</sup> Electric Heat Options are with Compressor and Outdoor Fan.

FLA = Full Load Amps

RLA = Rated Load Amps

LRA = Locked Rotor Amps

MCA = Minimum Circuit Ampacity



# Typical MicroTech Wiring Diagram – 208V / 60Hz / 1Ph

Figure 52: Typical MicroTech Controls Wiring Diagram – 208V / 60Hz / 1Ph

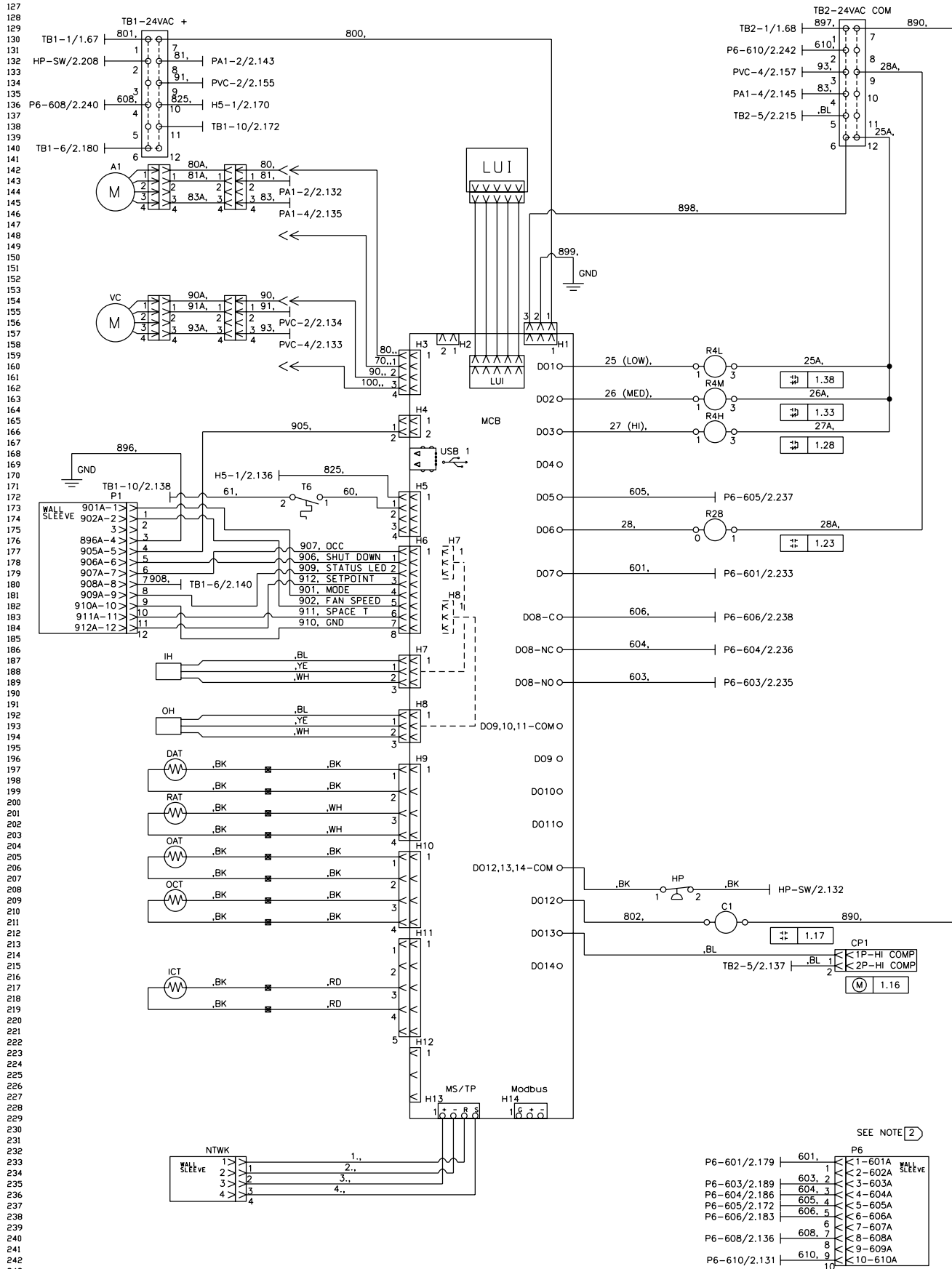

Note: See Figure 53 on page 66 for typical MicroTech service and disconnect wiring and wiring schematic legend.

# Typical MicroTech Wiring Diagram – Service & Disconnect 208V / 60Hz / 1Ph

Figure 53: Typical MicroTech Wiring Diagram – Service and Disconnect – 208V / 60Hz / 1Ph

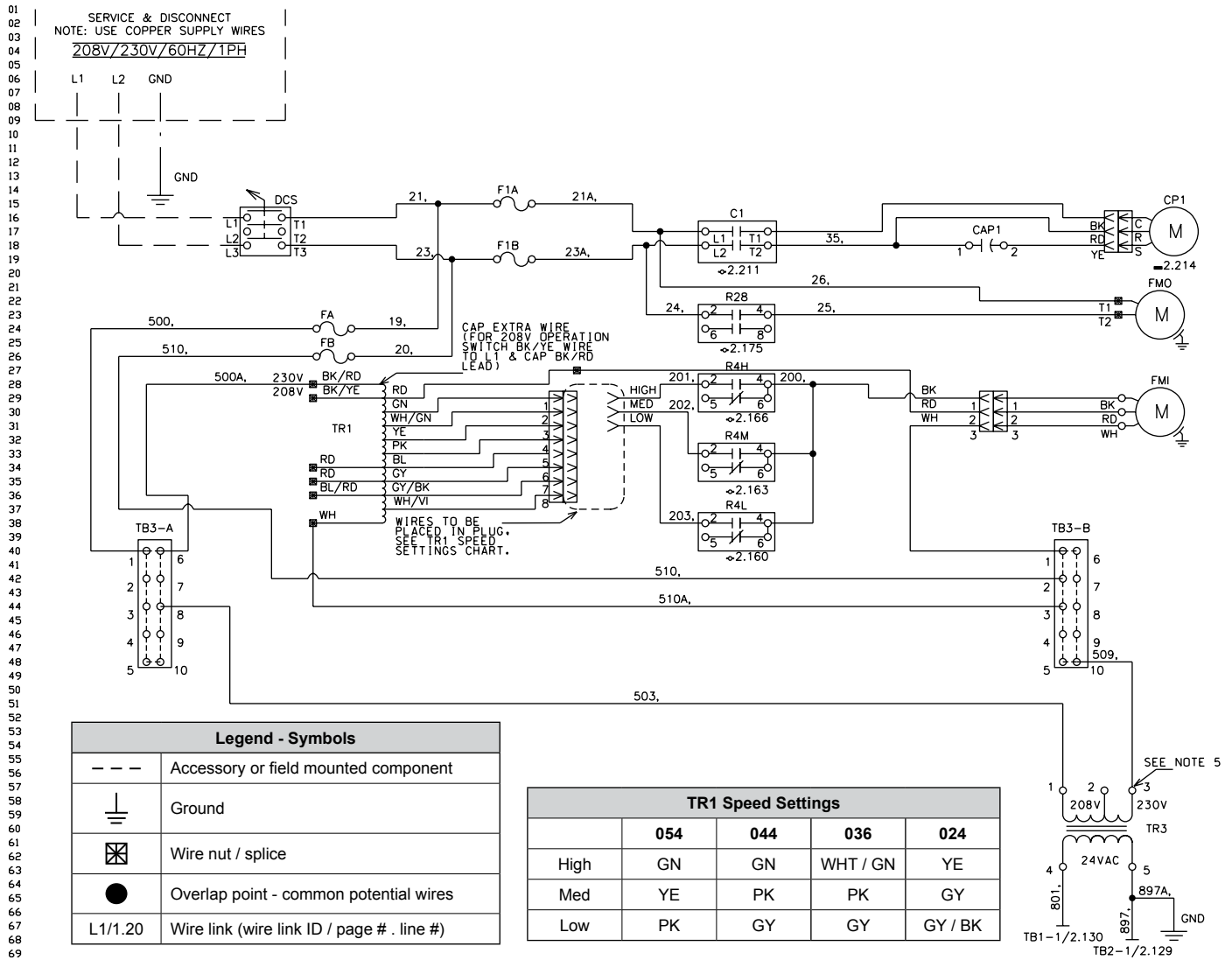

Table 36: Wiring Diagram Legend for Figure 52 on page 65 and Figure 53.

Symbol	Description	Symbol	Description	Symbol	Description
A1	Actuator- Outdoor Air	HP	High Pressure Switch	R32	Relay - Drain Pan Heater
A2	Actuator- Face & Bypass	ICT	Sensor - Indoor DX Coil Temperature	R28	Relay - Outdoor Motor Air
CP1	Motor Compressor 2-Stage	IH	Sensor - Indoor Humidity	RV	Reversing Valve
C1	Compressor Contactor	MCB	Main Control Board	RAT	Sensor - Room Air Temperature
CAP1	Capacitor Run	NTWK	Network Connection	T6	Thermostat - Freeze Stat
CEH1-3	Electric Heat Contactor	OAT	Sensor - Outdoor Air Temperature	TB1	Terminal Block - 24VAC+
CO2	Sensor - Indoor Air CO2	OCT	Sensor - Outdoor DX Coil Temperature	TB2	Terminal Block - 24VAC Gnd
DAT	Sensor - Discharge Air Temperature	OH	Sensor - Outdoor Humidity	TB3	(A, B) Terminal Block – Main Power
DCS	Switch - Unit Power	OH1	Thermostat - Overheat	TBE	Terminal Block - Electric Heat
DF	Dead Front Switch	OH2	Thermostat - Overheat	TR1	Transformer - Motor Speed
EH1-6	Heater - Electric	OHM	E.H. Man Reset - Overheat Stat	TR3	Transformer - 208 / 230V-24V, 75VA
EH10	Heater - Outdoor Drain Pan	PL1	LED Occupancy / Fault Status	TR4	Transformer - 460V-230V
F1A/F1B	Fuse - Compressor	R1-R3	Relay Electric Heat (Backup)	TR5	Transformer - 208 / 230V-24V
F2A/F3C	Fuse - Electric Heat	R10-R12	Relay – Electric Heat	V1	Valve - Heat EOC (Accessory)
FA/FB	Fuse– Control, Load	R4H	Relay – Fan High Speed	V2	Valve - Cool EOC (Accessory)
FC/FD	Fuse– Control, Transformer	R4M	Relay– Fan Medium Speed	VH	Valve - Heat (Accessory)
FMI	Motor - Room Fan	R4L	Relay– Fan Low Speed	VC	Valve - Cool (Accessory)
FMO	Motor Outdoor Air				

- Notes:**
- All electrical installation must be in accordance with national and local electrical codes and job wiring schematic.
  - External wiring options - see IM for the different configured options, wiring to be minimum 18 gauge, 90°C.
  - EC motors are factory programmed for specified air flow. Contact Daikin Applied for replacement.
  - Cap extra wire. Switch wire 42A to red wire for 208V operation.
  - Switch wire 509 to terminal 2 for 208V operation.
  - Devices in legend may or may not be on unit.

# Typical Wall Sensors Diagram

Figure 54: Wall-Mounted Temperature Sensor Wiring

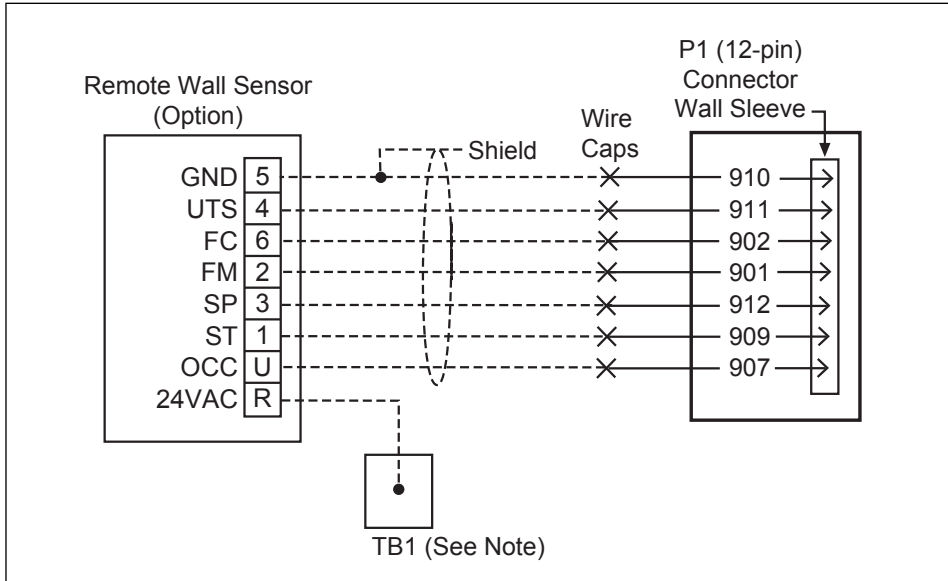

# Power & Control Field Wiring

Figure 55: External Input Wiring Examples with or without Daisy Chaining of Units

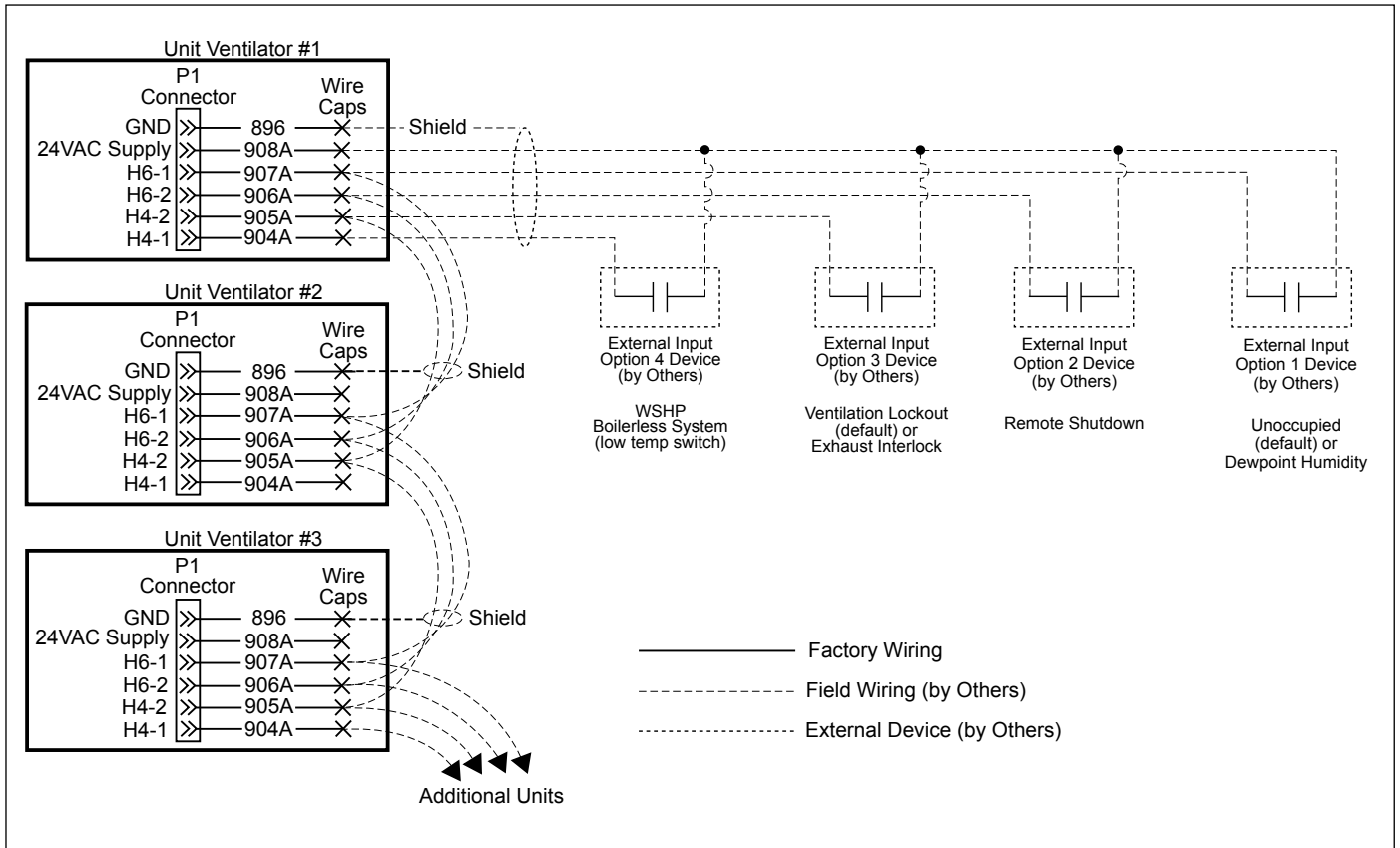

Figure 56: External Output Wiring - Single Unit

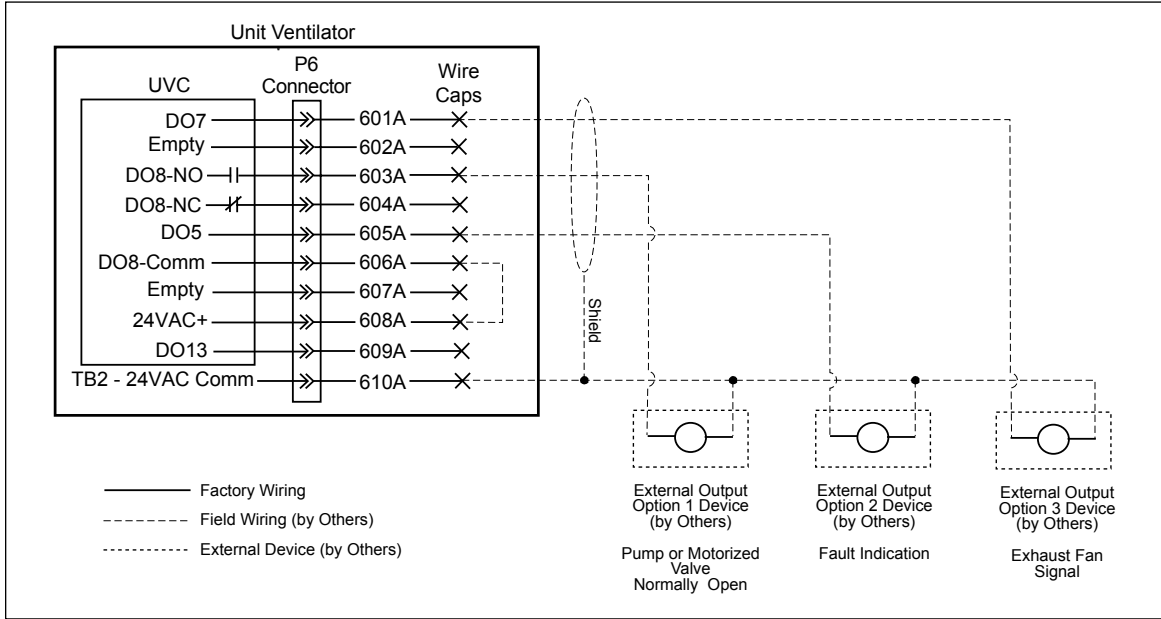
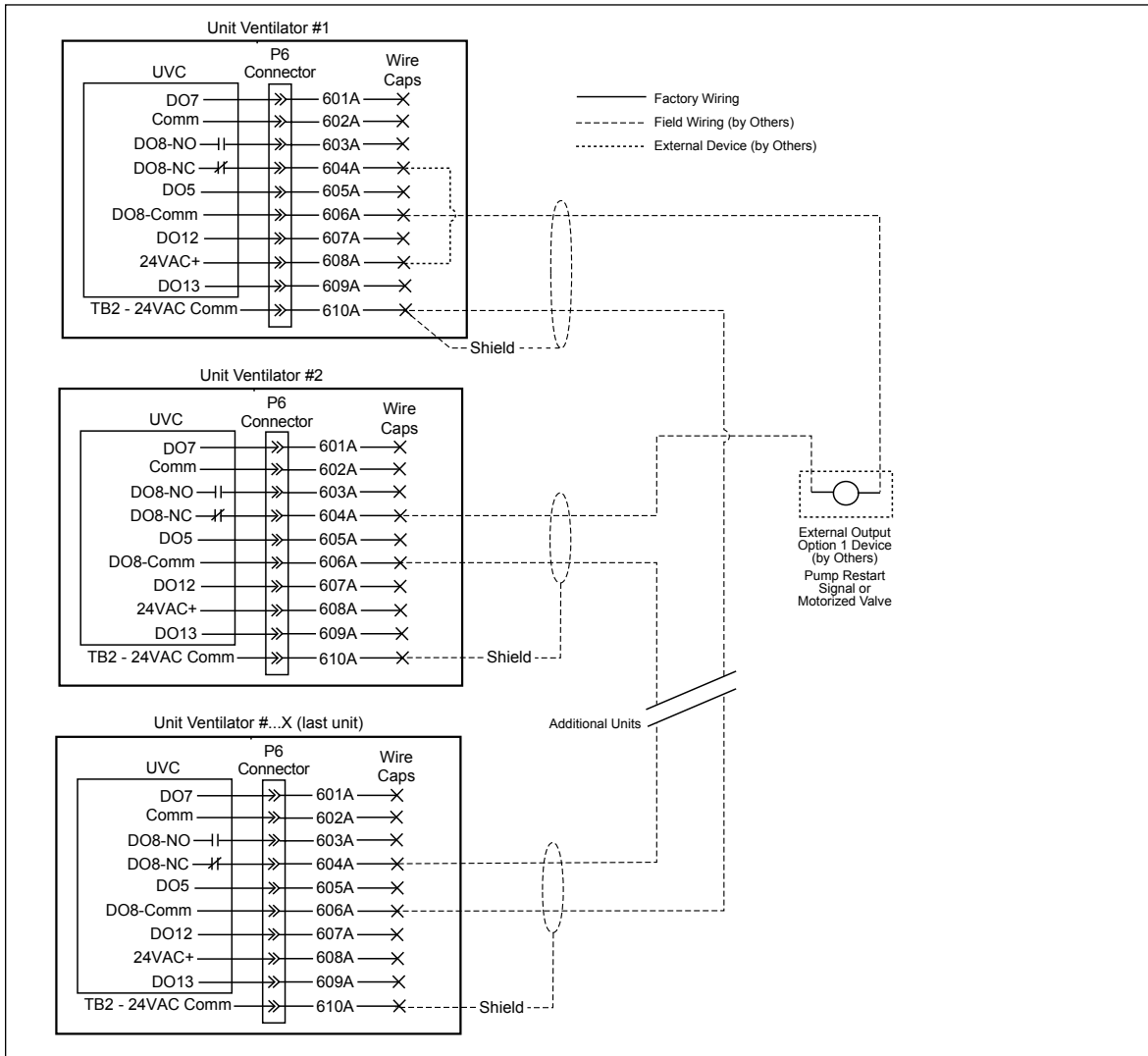
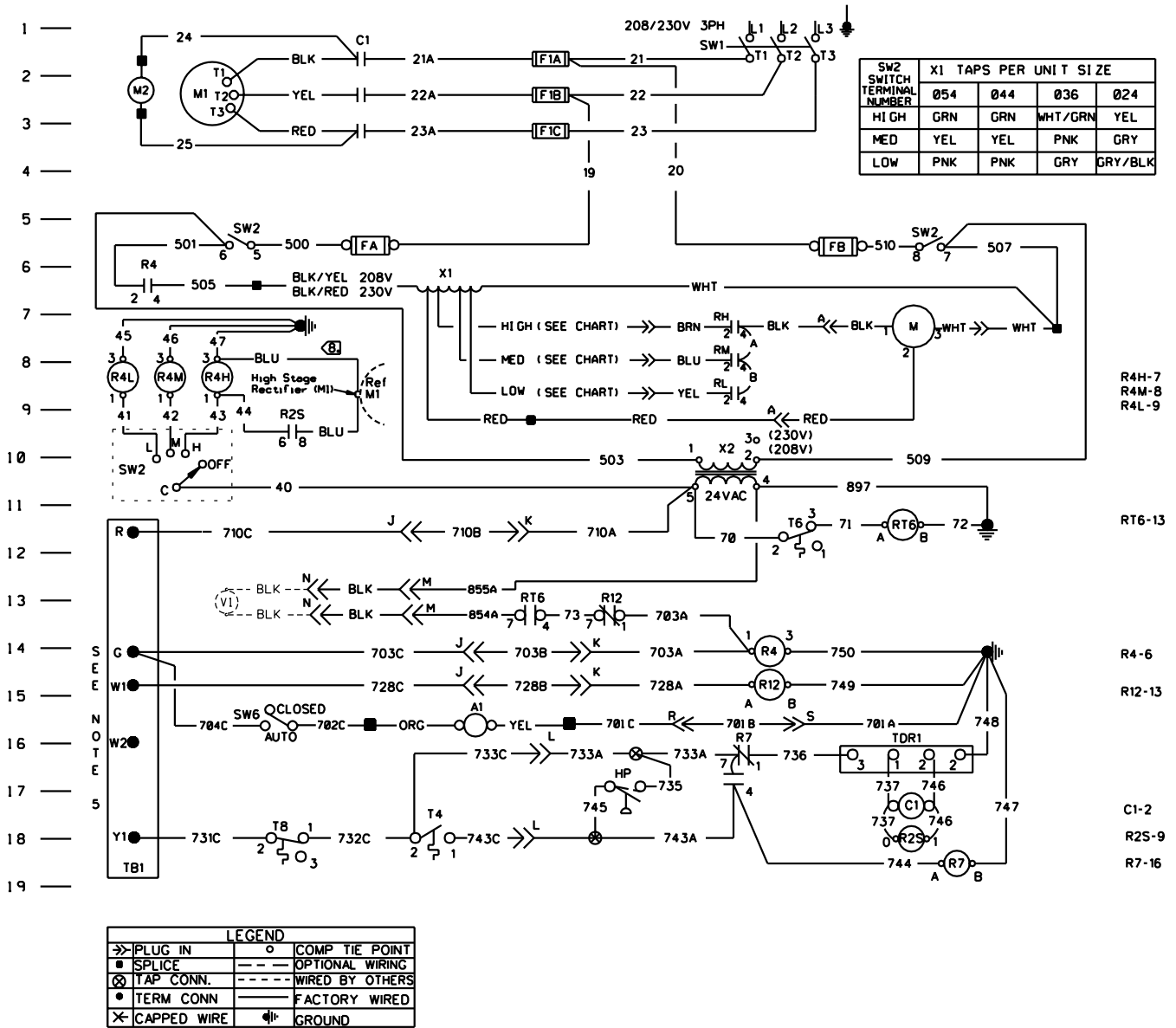

Figure 57: External Output Wiring - Multiple Units Shown



# ElectroMechanical Control

Figure 58: AZ Electromechanical Control with Hot Water Heat



**Note:** For troubleshooting, refer to unit-mounted schematic. See "Wiring Diagram Legend for Figure 58 on page" on page 70 for wiring diagram legend and notes.

**Table 37: Wiring Diagram Legend for Figure 58 on page 69**

Symbol	Description	Line No.	Symbol	Description	Line No.
A1	Actuator- Outdoor Air	18	R7	Relay Compressor Lockout	18
C1	Contactor- Compressor	17	R12	Relay- Heating	15
FA/FB	Fuse- Control	6	RT6	Relay Freeze Stat	12
F1A/F1C	Fuse- Compressor	1.3	SW1	Switch- Disconnect	1
HP	Switch- High Pressure (600 psi)	17	SW2	Switch- ON-OFF, Fan Speeds	5.10
M	Motor - Room Fan	7	TB1	Terminal Board- Control	19
M1	Compressor (2 Stage)	2	TDR1	Relay Time Delay Compressor (20.5V)	16
M2	Condensing Motor	2	T4	Thermostat Low Temp (28°F)	18
R2S	Relay High (2nd) Stage Compressor	18	T6	TStat- Low Limit	12
R4	Relay- Fan (Coil 24 VAC)	14	T8	Thermostat Cooling Lockout (59°F)	18
R4H	Relay- High Fan Speed (Coil 24 VAC)	8	V1	Valve (EOC) by others	13
R4M	Relay- Medium Fan Speed (Coil 24 VAC)	8	X1	Transformer- Motor	6
R4L	Relay- Low Fan Speed (Coil 24 VAC)	8	X2	Transformer- Control (75VA)	10

- Notes:**
1. All electrical installation must be in accordance with national and local electrical codes and job wiring schematic.
  2. NEC Class 1 wiring factory mounted night controls connect to Blk & Wht wires. When remote night controls are used, they must be connected to Blk & Wht wires shown capped, and the Blk & Wht wires in the main control box must be disconnected and individually capped.
  3. Numbers along right side of schematic designate the location of the contacts by line number.
  4. See control and thermostat drawing for additional controls.
  5. SW2 contact 5, 6 and 7, **8 open only when SW2 is in OFF position.**
  6. SW2 contacts H, M and L.
  8. High (2nd Stage) compressor rectifier energized when compressor is ON and fan speed is on HIGH.

## Control Modes and Functions

Daikin Applied unit ventilators equipped with MicroTech unit controllers can be programmed to operate in a variety of modes based on the current situation in the room and the status of the unit ventilator. Changes in mode can be triggered manually, via network signals, by sensor readings, or by date and time. External inputs and outputs can be used to change modes, communicate data to network controls or change the functional operation of the unit.

### Occupancy Modes

MicroTech unit controllers can be set up to change modes based on room occupancy. Four different occupancy modes are provided, as described below.

#### Occupied Mode

This is the normal daytime operation mode. The controller maintains a room set point using the outside air capability and other functions.

**Note:** *For non-school applications, the unit can also be configured to cycle the fan in response to the room load. In this case, the fan would normally be in the Off Mode until heating or cooling is required. The outside air damper is always closed when the fan is off. When the fan starts, the outside air damper opens to the required position, usually minimum position.*

#### Unoccupied Mode

This is the night setback operating mode, in which the unit responds to a new room set point and cycles to maintain the condition. The fan comes on when heating or cooling is needed and runs until the load is satisfied. The outdoor air damper is closed during this mode. When a cooling load is satisfied by a refrigerant system, the compressor is de-energized and the unit ventilator indoor fan continues to run for a fixed period of time to remove coldness from the evaporator coil. This reduces the potential for low refrigerant temperatures to exist on the evaporator coil.

#### Stand By Mode

In this mode, the unit maintains the occupied mode set point temperature with the outdoor air damper closed. The fan runs continuously unless it is configured to cycle in response to the load.

#### Bypass Mode

This is a tenant override operating mode initiated by using the optional LUI or by depressing the tenant override switch on the optional room sensor. The unit is placed back into occupied mode for a predetermined time (default 120 minutes). This time can be set in 1-minute increments from 1 minute to 240 minutes through the unit ventilator service tool or a network.

## Economizer Modes

Economizer operation is facilitated by the outdoor air damper, which automatically adjusts the above-minimum outside air position to provide free cooling when the outdoor air temperature is appropriate. Three levels of economizer control are available:

**Basic Economizer Operation:** The MicroTech controller compares the inside and outside temperatures. If the temperature comparison is satisfactory, then free-air economizer operation is used to cool the space. Reheat units also come configured with an indoor humidity sensor.

**Expanded Economizer Operation:** In addition to comparing inside and outside temperatures, outdoor relative humidity is measured to calculate outside air enthalpy. If the enthalpy set point is not exceeded, and the temperature comparison is satisfactory, then free economizer operation is used to cool the space. This helps to minimize the entrance of humid outside air.

**Leading-Edge Economizer Operation:** The MicroTech controller compares both indoor and outdoor temperatures and indoor and outdoor relative humidities. Then it calculates both inside and outside air enthalpy to determine if free economizer operation can cool the space with non-humid outside air. This is a true enthalpy economizer—a first for unit ventilators.

### Night Purge Mode

Under this mode, the unit is configured to purge the room space for one hour for various reasons (odor or fume removal, drying, etc.). During Night Purge the outside air damper is open full and the fan is run on high speed. No “normal” heating or cooling takes place (the emergency heat set point is maintained) and the exhaust fan, if the room is so equipped, is signaled to turn on.

### Freeze Prevention Mode

This mode helps protect the unit ventilator from freezing air conditions. Control functions vary depending on the type of temperature control used by the unit, as follows:

### Face and Bypass Control Units

Upon sensing a potential freezing air temperature condition leaving the heating coil, the unit will automatically protect itself by shutting the outside air damper and opening the EOC valve. The face and bypass damper is allowed to operate normally to control the space. The fan continues to run to remove the cold air. Once accomplished, the freeze stat is reset, the outside air damper opens to the minimum position and the unit commences its normal mode of operation.

## Valve Control Units

Upon sensing a potential freezing air temperature condition leaving the heating coil, the unit will automatically protect itself by shutting the outside air damper and opening the hot water valve to a minimum of 50% (more if required to heat the room). The fan speed will be staged down to low speed and then turned off. When the freeze-stat is reset, the outside air damper opens to the minimum position and the fan runs at low speed for a minimum of 10 minutes. It then will stage up if needed to satisfy the room set point. This reduces the potential to overheat a room recovering from a potential freeze condition.

**Note:** *Valve selection and coil sizing is critical for proper operation. Face and bypass control is recommended for proper humidity and freeze protection.*

## Emergency Heat Mode

If the unit is left in a mode that does not normally allow heating (such as Off, Fan Only, Cool, or Night Purge) and the room temperature falls below 55°F, the unit will heat the space to above 55°F and then return to the previously set mode of operation. This mode of operation can be field configured and/or be disabled.

## External Input Functions

The unit ventilator controller is provided with four (4) binary inputs that allow a single set of dry contacts to be used as a signal to it, and two (2) binary inputs that allow a 24VAC signal. Multiple units can be connected to a single set of dry contacts.

**Note:** *Not all of the functions listed can be used at the same time. The unit ventilator controller is provided with configuration parameters that can be adjusted to select which function will be used for these inputs where multiple functions are indicated below.*

### Unoccupied Input Signal

This input signals the unit ventilator controller to go into unoccupied or occupied mode. When the contacts close, the unit ventilator controller goes into unoccupied mode; when the contacts open, it goes into occupied mode. Additional variables can affect occupancy mode and override this binary input. See "[Occupancy Modes](#)" on [page 71](#).

### Dewpoint/Humidity Input Signal (Optional)

This input signals the unit ventilator controller to go into active dehumidification mode. When the contacts close (high humidity) the controller will go into active dehumidification; when the contacts open (low humidity) it will stop active dehumidification.

### Remote Shutdown Input Signal

This input signals the unit ventilator controller to go into shutdown mode. When the contacts close, the controller goes into shutdown mode; when the contacts open, it returns to normal operation.

### Ventilation Lockout Input Signal

This input signals the unit ventilator controller to close the outdoor air damper. When the contacts close (ventilation lockout signal) the controller closes the outdoor damper; when the contacts open, it returns to normal outdoor damper operation.

### Exhaust Interlock Input Signal

This input signals the unit ventilator controller that an exhaust fan within the space has been energized. The controller then repositions the outdoor air damper to a user-adjustable minimum position. When the contacts close (exhaust fan on signal) the controller uses the value defined by the Exhaust Interlock OA Damper Min Position Setpoint as the new minimum outdoor air damper position regardless of the indoor air fan speed. When the contacts open, it returns to normal outdoor damper operation.

## External Output Functions

The unit ventilator controller is provided with three (3) binary outputs to perform the functions described below. These are relay type outputs that supply 24VAC.

**Note:** *Not all of the functions listed can be used at the same time. The unit ventilator controller is provided with configuration parameters that can be adjusted to select which function will be used for these outputs when multiple functions are indicated below.*

### Fault Signal

This relay output provides one set of NO (reversible through keypad/software) 24VAC contacts that can be used to signal a fault condition. When a fault exists, the unit ventilator controller energizes this relay output. When the fault or faults are cleared, it de-energizes this relay output.



### **Exhaust Fan On/Off Signal**

This relay output provides one set of NO (reversible through keypad/software) 24VAC contacts that can be used to signal the operation of an exhaust fan. When the outdoor air damper opens more than the Energize Exhaust Fan OA Damper Setpoint, the relay output will signal the exhaust fan on (contacts closed). When the outdoor damper closes below this setpoint, the relay output will signal the exhaust fan off (contacts open).

### **Auxiliary Heat Signal**

This relay output provides one set of NO (reversible through keypad/software) 24VAC contacts that can be used to operate an auxiliary heat device. The unit ventilator controller by default is configured to operate a NO auxiliary heat device (de-energize when heat is required) such as a wet heat valve actuator with a spring setup to open upon power failure. However, the Auxiliary Heat Configuration variable can be used to set the controller to use an NC auxiliary heat device (energize when heat is required) such as electric heat.

## **Advanced Control Options**

MicroTech controls make possible a number of advanced control options that can quickly pay for themselves in saved energy costs and more comfortable classrooms, as described below.

### **Part Load Variable Air Control**

Part Load Variable Air control can be used in conjunction with face and bypass damper temperature control to automatically adjust the unit ventilator fan speed based upon the room load and the room-temperature PI control loop. This MicroTech control option provides higher latent cooling capabilities and quieter operation during non-peak load periods by basing indoor fan speed upon room load.

During low-load or normal operation (about 60% of the time) the fan will operate on low speed. When the load increases to an intermediate demand, the fan will automatically shift to the medium-speed setting. Under near-design or design-load conditions, the fan will operate on high speed. A built-in, 10-minute delay helps minimize awareness of fan speed changes. Low-speed fan operation under normal operating conditions, in conjunction with our GentleFlo fan technology contributes to a very quiet classroom environment.

## **Demand-Controlled Ventilation (Optional)**

Daikin unit ventilators can be equipped to use input from a CO<sub>2</sub> controller to ventilate the space based on actual occupancy instead of a fixed design occupancy. This Demand Controlled Ventilation (DCV) system monitors the amount of CO<sub>2</sub> produced by students and teachers so that enough fresh outdoor air is introduced to maintain good air quality. The system is designed to achieve a target ventilation rate (e.g., 15 CFM/person) based on actual occupancy.

By using DCV to monitor the actual occupancy pattern in a room, the system can allow code-specific levels of outdoor air to be delivered when needed. Unnecessary over-ventilation is avoided during periods of low or intermittent occupancy.

With DCV you can be confident that your school is meeting ventilation standards for Indoor Air Quality and that your students are receiving adequate air to be attentive to instruction. At the same time, you are saving money in early morning hours, in between classes, or after hours when classrooms are heated and cooled but not always fully occupied.

### **As Simple As A Thermostat**

Demand Controlled Ventilation is easy to apply. When DCV is ordered, a CO<sub>2</sub> sensor is mounted on the unit and configured for operation. The system does the rest. If desired, the ventilation control setpoint can be adjusted through the MicroTech Controller.

### **Acceptance By Codes And Standards**

ASHRAE Standard 62-2004 Ventilation for Indoor Air Quality recognizes CO<sub>2</sub> based DCV as a means of controlling ventilation based on occupancy. The ASHRAE standard has been referenced or adopted by most regional and local building codes. This standard references ventilation on a per-person basis.

Using CO<sub>2</sub> control will sometimes lower the absolute amount of outside air delivered into a room but will maintain the per-person rate. For example, if a classroom is designed for 30 students, the ventilation rate is 450 CFM (30 students × 15 CFM/student). However, when there are only ten students in the classroom, the CO<sub>2</sub> control will adjust ventilation to 150 CFM (10 students × 15 CFM/student). A minimum base ventilation rate (typically 20% of design levels) is provided when in the occupied mode. This provides outdoor air to offset any interior source contamination while allowing for proper space pressurization.

## Active Dehumidification Control (Reheat)

In high-humidity applications where valve-controlled, reheat units are used, the Active Dehumidification Control (ADC) sequence should be considered. During excessive humidity conditions, a humidity sensor directs the unit to continue cooling past the room setpoint to remove excess moisture. Hydronic heat or electric heat is then used to reheat the discharge air to maintain acceptable room temperatures.

MicroTech controls minimize the amount of reheat needed to maintain relative humidity below a preset limit. Reheat is used only when required and in the most energy-efficient manner possible.

Active Dehumidification comes standard on units equipped with MicroTech controls, a reheat configuration and valve-control temperature modulation. The MicroTech ADC humidity sensor is unit-mounted. It issues a signal proportional to the classroom's humidity level (unlike humidistats which issue an open-close signal). This enables a control sequence that manages both the temperature and the relative humidity.

When the relative humidity exceeds a preset value, the refrigerant cooling activates to dehumidify the mixture of outdoor and return air entering the cooling coil. The reheat modulating water valve then opens, or electric heat is engaged, to reheat the air leaving the cooling coil, as required to maintain the classroom setpoint.

Active dehumidification starts when the indoor relative humidity exceeds the preset relative humidity upper setpoint and continues until the room humidity falls 5% below the endpoint. During active dehumidification, economizer operation is disabled (and the outdoor air damper is reset to its minimum position) unless the outdoor air temperature is below 55°F. It is maintained until dehumidification is completed. When the indoor humidity level is satisfied, the MicroTech controller reverts to its normal sequences to satisfy the classroom temperature setpoint.

## DX System Control

The unit ventilator controller is configured to operate the compressor as secondary (mechanical) cooling when economizer cooling is available, and as primary cooling when economizer cooling is not available. Additional DX control features include:

**Compressor Cooling Lockout:** The unit ventilator controller is configured to lock out compressor cooling when the outdoor air temperature falls below the compressor cooling lock out setpoint. Below this temperature setpoint only economizer cooling will be available.

**Minimum On And Off Time:** The unit ventilator controller is provided with minimum-on and minimum-off timers to prevent adverse compressor cycling (3-minutes default).

**Compressor Start Delay Variable:** This variable is intended to be adjusted as part of the start-up procedure for each unit. It is used to prevent multiple unit compressors from starting at the same time after a power failure or after an unoccupied-to-occupied changeover. Each unit should be configured at start-up with a slightly different (random) delay, or groups of units should be provided with different delays.

## System Components

The main components of the MicroTech system are:

- A Unit Ventilator Controller (UVC) with on-board BACnet MS/TP communications
- Optional Local User Interface (LUI)
- Optional Lon plug-in network communication module

In addition, unit ventilators equipped with MicroTech controllers feature factory-mounted sensors and actuators for system control and feedback.

## Unit Ventilator Controller

The MicroTech UVC is a DDC, microprocessor-based controller designed to provide sophisticated comfort control of an economizer-equipped Daikin unit ventilator. In addition to normal operating control, it provides alarm monitoring and alarm-specific component shutdown if critical system conditions occur. Each UVC is factory wired, factory programmed and factory run-tested for the specific unit ventilator model and configuration ordered by the customer.

**Figure 59: MicroTech Control Board**

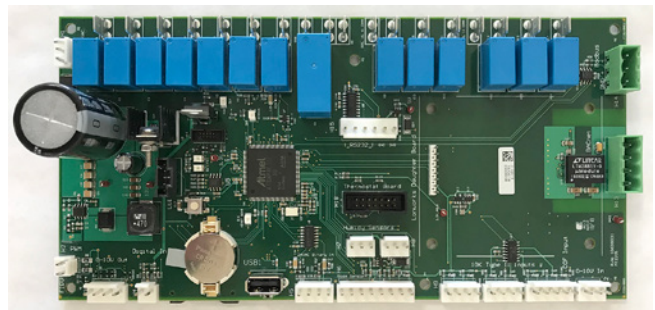

## Local User Interface (Optional)

An optional built-in LUI touch pad with digital LED Display is located in the right hand compartment below the top right access door. The LUI features a 4 x 20 OLED digital display, 4 keys, and 2 individual LED indicators. In addition to the Operating Mode States and Fan Functions, the Touch Pad will digitally display:

- The room set point temperature.
- The current room temperature.
- Any fault code for quick diagnostics at the unit.

**Figure 60: User Interface Touch Pad**



The User Interface has individual touch-sensitive printed circuit board mounted buttons, and comes with a built-in menu structure (Hidden Key and Password Protected) to change many of the common operating variables.

### Four Operating Mode States

Four different user operating mode states can be chosen on the LUI:

**Heat:** Heating and economizer operation only.

**Cool:** Cooling and economizer operation only.

**Fan Only:** Fan only operation.

**Auto:** The unit automatically switches between heating, cooling and economizer operation to satisfy the room load conditions. The current unit state is also displayed.

### Four Fan States

Four fan states are provided on all units: high, medium low and Auto speed modulation. The Auto speed function (part load, variable air) varies the fan speed automatically to meet the room load whether the unit is in heating, cooling or economizer mode.

All this is accomplished with a standard, single-speed NEMA frame motor. A built-in 10-minute delay helps minimize awareness of speed changes. During low-load or normal operation (about 60% of the time) the fan will operate at low speed. The low speed operation, along with GentleFlo fan technology, contributes to a very quiet classroom environment.

When the load increases to an intermediate demand, the fan automatically shifts to the medium speed setting. At near-design or design-load conditions the fan will operate on high speed.

With four fan states and GentleFlo fan technology, there is no need to oversize units or worry about uncomfortable conditions.

### Communication Types

On-board BACnet communication or the optional LONWORKS communication module provide control and monitoring information to your building automation system without the need for costly gateways. Information on BACnet and the optional LONTALK communication module are described below.

#### **MicroTech Controller with on-board BACnet MS/TP**

The MicroTech controller allows the UVC to inter-operate with systems that use the BACnet (MS/TP) protocol with a conformance level of 3. It meets the requirements of the ANSI/ASHRAE 135-2008 standard for BACnet systems.

#### **LONWORKS SCC Communication Module**

This module supports the LONWORKS SCC (Space Comfort Communication) profile number 8500-10. Unit controllers are LONMARK certified with this optional LONWORKS communication module.

# MicroTech Sensor and Component Locations

Figure 61: MicroTech Sensor and Component Locations

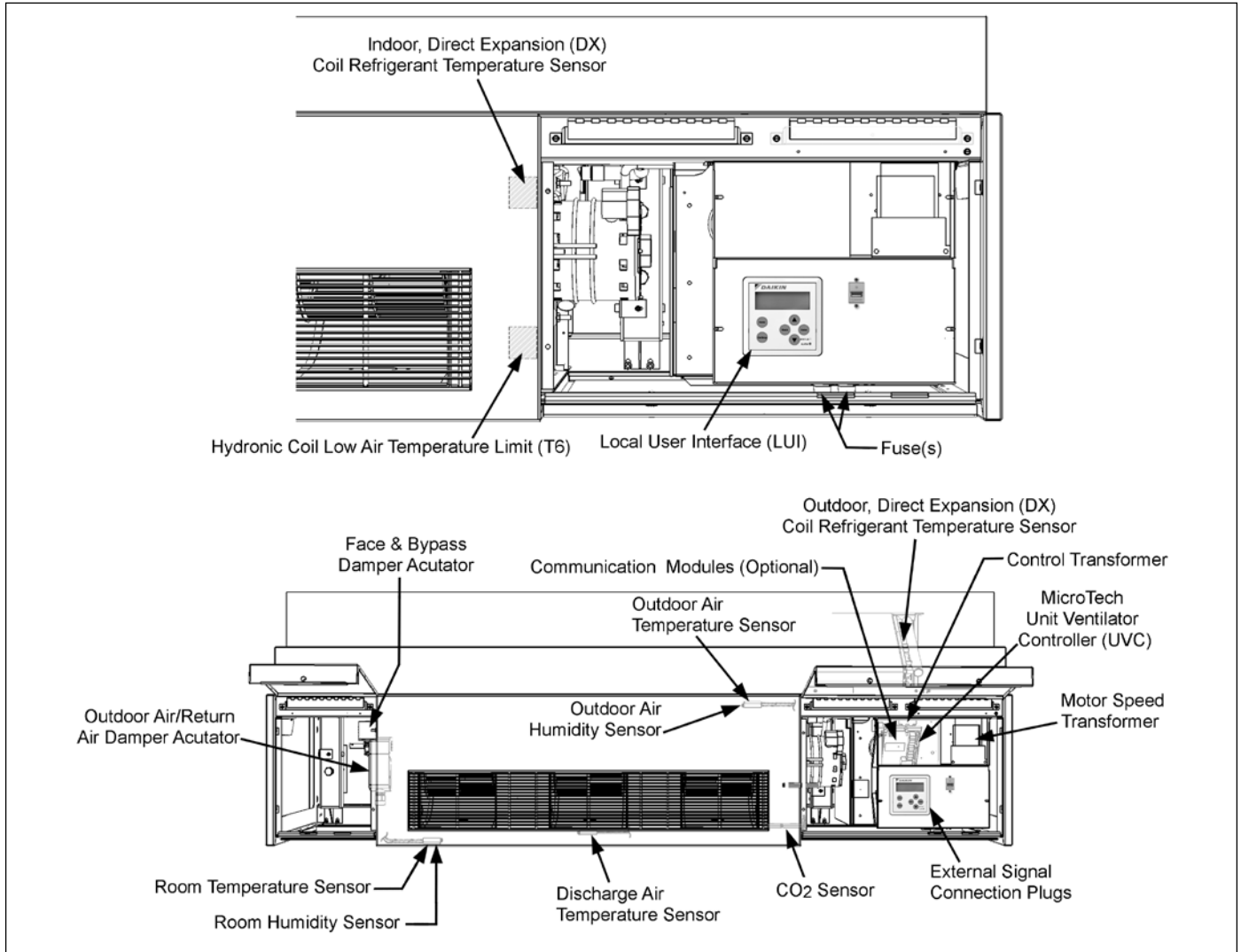

## CO2 Sensor for Demand Controlled Ventilation

On units equipped for Demand Controlled Ventilation (DCV), the UVC is configured to use a 0-2000 PPM, 0-10 VDC, single beam absorption infrared gas sensor. CO2 sensors are available as unit mounted only. An air collection probe (pitot tube and filter) is installed in the return air of the unit (Figure 62).



Figure 62: CO2 Sensor For Demand Control Ventilation



## Room Temperature Sensors used with MicroTech Unit Controls

### Digitally Adjustable Display Sensor – 910247458

The display sensor is used in conjunction with MicroTech equipped units. This digitally adjustable sensor displays room temperature, fan speed (AUTO/HIGH/MEDIUM/LOW), system mode (HEAT/COOL/AUTO/OFF), ALARM, override and occupancy.

### Digitally Adjustable Display Sensor – 910247448

The display sensor is used in conjunction with MicroTech equipped units. The sensor has a digital display for temperature, occupancy, alarm, setpoint and status indication. Controls include four buttons for setpoint, occupied/unoccupied request, and override reset.

### Basic Room Sensor With Cool to Warm – 910247453

The basic room sensor with adjustment (cool to warm) is used in conjunction with MicroTech equipped units. The sensor has an output for temperature, and LED status indication and includes an override reset button.

### Basic Room Sensor – 910247450

The basic room sensor is used in conjunction with MicroTech equipped units. The sensor has an output for temperature, and LED status indication and includes an override reset button.

Table 38: Room Temperature Sensors for BAS Operation

Room Temperature Sensors used with Unit Ventilator – Building Automated System (BAS) Operation		Digitally Adjustable Display Sensor	Digitally Adjustable Display Sensor	Basic Room Sensor With Cool to Warm Adjust	Basic Room Sensor
		Part No. 910247458	Part No. 910247448	Part No. 910247453	Part No. 910247450
<b>Feature</b>					
<b>Setpoint Adjustment</b>		Digitally Adjustable	Digitally Adjustable	Cool to Warm	None
<b>Display</b>	Room Temperature & Setpoint	●	●		
<b>Operating Modes</b>	System	Heat-Cool-Auto-Off-			
	Fan	Auto-High-Medium-Low			
	Occupancy	LCD Display of Occupied-Unoccupied Icon	LCD Display of Occupied-Unoccupied Icon		
<b>Annunciation</b>	Status LED	LCD Display of Unit Status	LCD Display of Unit Status	●	●
	LCD Alarm Display	●	●		
<b>Reset</b>	Alarm	●	●	●	●
	Setback Override	●	●	●	●

## Actuators

### Face & Bypass Damper Actuator

On units equipped with face & bypass damper control, the UVC is configured to operate a proportional, direct-coupled, face & bypass damper actuator. To increase accuracy, the controller has an overdrive feature for the 0% and 100% positions and a periodic (12-hour) auto-zero PI control loop for each modulating actuator.

Figure 63: Face & Bypass Actuator



### Outdoor Air/Return Air Damper (OAD) Actuator

The UVC is configured to operate a proportional, direct-coupled actuator for the outdoor air damper. This actuator provides spring-return operation upon loss of power for positive close-off of the outdoor air damper. To increase actuator positioning accuracy, the UVC is provided with an overdrive feature for the 0% and 100% positions and a periodic (12-hour) auto-zero PI control loop for each modulating actuator.

Figure 64: Outdoor Air Damper Actuator



### 2-Position End-of-Cycle Valve Actuators (Optional)

On units equipped with 2-way or 3-way, end-of-cycle (EOC) valves, the UVC is configured to operate 2-position End-Of-Cycle (EOC) valve actuators (Figure 65). Spring return actuators are used for all End of Cycle (EOC) valves. All wet heat and heat/cool EOC valves are normally open, and all cooling EOC valves are normally closed.

Figure 65: End of Cycle Valve Actuator



### Modulating Valve Actuators (Optional)

On units equipped with modulating valves, the UVC is configured to operate proportional actuators for modulating 2-way and 3-way valves (Figure 66).

Figure 66: Modulating Valve Actuators



2-Way Valve



3-Way Valve

## A Wide Variety of Input, Output & Alarm Data Points Available

A wide variety of data is available from Daikin Applied unit ventilators when equipped with MicroTech unit controllers in a network situation. They provide a clear

picture of just what's happening in each classroom and notify your building automation system of alarm conditions regardless of the protocol you select. [Table 39](#) below shows a list of inputs, outputs and alarm functions available.

**Table 39: Network Operation -Typical Data Points<sup>1</sup>**

Read/Write Attributes	Read Only Attributes	Read/Write Setpoint Attributes	Typical Alarms
<ul style="list-style-type: none"> <li>• Application Mode</li> <li>• Compressor Enable</li> <li>• Emergency Override</li> <li>• Energy Hold Off</li> <li>• Heat/Cool Mode</li> <li>• Occupancy Override</li> <li>• Outdoor Air Humidity</li> <li>• Outdoor Air Temperature</li> <li>• Reset Alarm</li> <li>• Reset Filter Alarm</li> <li>• Source (Water In) Temperature</li> <li>• Space CO<sub>2</sub></li> <li>• Space Humidity</li> <li>• Space Temperature</li> <li>• Economizer Enable</li> <li>• Heating Setpoint Shift</li> <li>• Cooling Setpoint Shift</li> </ul>	<ul style="list-style-type: none"> <li>• Binary Input Status</li> <li>• Binary Output Status</li> <li>• UV Software Application Version</li> <li>• Compressor Run Time</li> <li>• Chiller Water Valve Position</li> <li>• Discharge Air Temperature</li> <li>• Discharge Air Temperature Setpoint</li> <li>• Effective Setpoint</li> <li>• Fan Speed</li> <li>• F &amp; BP Damper Position</li> <li>• Outdoor Air Damper Position</li> <li>• Space Fan Runtime</li> <li>• Unit Ventilator Controller State</li> <li>• Water-Out Temperature</li> <li>• WH or CW/HW Valve Position</li> <li>• OA Minimum Position</li> </ul>	<ul style="list-style-type: none"> <li>• Econ. IA/OA Enthalpy Differential Setpoint</li> <li>• Econ. IA/OA Temp. Differential. Setpoint</li> <li>• Econ. Outdoor Air Enthalpy Setpoint</li> <li>• OAD Min. Position Low-Speed Setpoint</li> <li>• OAD Min. Position Med.-Speed Setpoint</li> <li>• Occupied Cooling Setpoint</li> <li>• Occupied Heating Setpoint</li> <li>• Space CO<sub>2</sub> Setpoint</li> <li>• Space Humidity Setpoint</li> <li>• Standby Cooling Setpoint</li> <li>• Unoccupied Cooling Setpoint</li> <li>• Unoccupied Heating Setpoint</li> </ul>	<ul style="list-style-type: none"> <li>• Indoor Air Temperature Sensor Failure</li> <li>• DX Pressure Fault</li> <li>• Indoor Air Coil DX Temperature Sensor Failure</li> <li>• Outdoor Air Temperature Sensor Failure</li> <li>• Discharge Air Temperature Sensor Failure</li> <li>• Outdoor Air Coil DX Temperature Sensor Failure (or)</li> <li>• Water Coil DX Temperature Sensor Failure</li> <li>• Water-Out Temperature Sensor Failure (or)</li> <li>• Water-In Temperature Sensor Failure</li> <li>• Space Humidity Sensor Failure</li> <li>• Outdoor Humidity Sensor Failure</li> <li>• Space CO<sub>2</sub> Sensor Failure</li> <li>• Source Temperature (Water-In) Inadequate Indication</li> <li>• Change Filter Indication</li> </ul>

<sup>1</sup> Not all data points or alarms listed will be available in all unit ventilator configurations. Humidity and CO<sub>2</sub> points require the use of optional sensors.

## ServiceTools™

ServiceTools for MicroTech Unit Ventilators is software for operation on a personal computer. This software provides representation of the sequence of operation and enables the service technician to:

- Monitor equipment operation
- Configure network communications
- Diagnose unit operating problems
- Download application code and configure the unit

This software is a purchased tool for service technicians and will run on PCs with Microsoft Windows, Windows 7 and newer operating systems.

This tool provides more capabilities than the unit's user interface touch pad and is highly recommended for startup and servicing. (It may be required for startup and/or servicing, depending upon unit integration and other requirements.) It does not replace BAS functions, such as system wide scheduling or sequencing, and it cannot serve as a Work Station Monitoring package. ServiceTools interfaces with the MicroTech controller using serial communications through a USB type A connector.

## Setpoints and Configuration Parameters

The UVC can save a snapshot of all setpoints and configuration parameters in the controller. Those configurations and setpoints can be saved onto a SD flash memory card, ensuring the controller can be reverted to those settings at a later date. Additionally, the settings saved to a SD can be taken to another UVC and loaded into it. Certain parameters, such as BACnet addressing and location, can be optionally restored to prevent duplication.

## Data Trending

Data can be written to an optional SD card inserted into the control unit. The parameters that can be trended through MicroTech can be found in OM 732. Six options for trending frequency are available:

- None
- 10 Minutes
- Occupancy Change
- Hourly
- 1 Minute
- Daily

A separate trend file will be created of each day. If a "Daily" trend is selected, the trend file will contain a header and 1 line of data. If an "Hourly" trend is selected, the trend file will contain a header and 24 lines of data. The last 3 alarms in the Alarm History are always recorded.

## Why Classrooms Overheat

Overheated classrooms occur every day in schools in every area of the country. The most serious result is their detrimental effect on students' ability to concentrate and learn. Research has determined that the ability to learn and retain knowledge decreases rapidly as the temperature exceeds recommendations. Overheated rooms also represent wasted fuel, resulting in excessive operating costs.

Correcting an overheating problem in an existing building is very difficult and expensive. It calls for redesign and alteration of the heating and ventilating system, necessitating considerable renovation. This potential problem should be recognized, understood and planned for when heating and ventilating systems are designed for new and existing buildings.

## Schools Have Special Needs

Schools have unique heating and ventilating needs, in large part because of their variable occupancy and usage patterns. Fewer cubic feet of space is provided per student in a school building than in any other type of commercial or public building. School classrooms are typically occupied only six hours a day, five days a week, for only three-fourths of the year, with time out for vacations. All in all, this represents approximately 15% of the hours in a year that a classroom is occupied.

To understand the overheating problem in schools, one must first realize that the excess heat comes from what is commonly termed "uncontrolled heat sources." To gain some perspective on how this affects heating and cooling decisions, let's take a look at a typical classroom in the northern section of the mid western United States.

Suppose we have a classroom that is 24 by 38 feet with 10-foot ceilings and 100 square feet of window area along the outside wall. At an outside temperature of 0°F and a desired room temperature of 72°F, let's assume the normal amount of heat loss from the room to the outside is 55,000 BTUs per hour.

As the outside temperature changes, so does the amount of heat that the room loses. This is represented in Figure 67 by Room Heat Loss Line A, which ranges from 55,000 BTUs per hour at 0°F outside air temperature to zero BTUs at 70°F. Obviously, if the heating system were the only source of heat in the classroom, the solution would be simple: The room thermostat would cause the heating system to supply exactly the amount of heat required to maintain the room at the thermostat temperature setting. In reality, the introduction of excess heat from a variety of uncontrolled sources makes the challenge considerably more complex.

Figure 67: Heat Gain Vs. Heat Loss In Occupied Classrooms

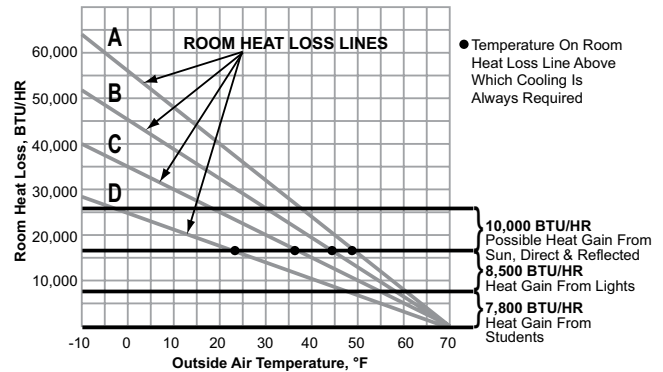

As Figure 67 illustrates, even in very cold weather an occupied classroom is more likely to require cooling than heating.

### Heat From Students

Body heat generated by students in a classroom is one of the three primary sources of uncontrolled heat. In a typical classroom of 30 students, the amount of heat given off at all times will vary according to factors such as age, activity, gender, etc. A conservative estimate is 260 BTUs per hour per pupil. Multiply this by 30 and you get a total of 7,800 BTUs per hour added to the room by the students alone. This excess heat is noted in Figure 67 as "Heat Gain from Students."

### Heat Gain From Lights

Heat emitted by the lighting system constitutes a second uncontrolled heat source. Artificial lighting is needed in most classrooms even during daylight hours to prevent unbalanced lighting and eye strain. A typical classroom requires approximately 2,500 watts of supplemental lighting to provide properly balanced lighting. Fluorescent lights add heat to the room at the rate of 3.4 BTU per watt per hour, or a total of 8,500 BTU per hour. This extra heat is represented in Figure 67 as "Heat Gain from Lights."

Add the heat gain from lighting to the 7,800 BTUs introduced by student body heat and we now have an extra 16,300 BTU/HR being introduced into the classroom by uncontrolled sources. This heat gain remains constant regardless of the outdoor air temperature.

### Solar Heat Gain

The sun is a third uncontrolled source of heat. And, because it is neither positive nor constant, calculating its contribution to the overall heat gain is difficult. Solar heat gain can be the worst offender of the three in classrooms with large windows. Indirect or reflected solar radiation is substantial even on cloudy days, even in rooms with north exposure, as a result of what is termed "skyshine."



To get an idea of the potential effect of the sun, let's assume that the solar heat gain in our hypothetical classroom will peak at 240 BTU/HR per square foot of glass area. If we then assume a glass area of 100 square feet and at least

100 BTU/HR per square foot of glass for solar heat gain, we can calculate a very conservative estimate of 10,000 BTU/HR heat gain through windows. If we add this to the heat from the lights and body heat, total heat gain adds up to 26,300 BTU/HR from sources other than the heating and ventilating system. This is indicated in [Figure 67 on page 80](#) by the top horizontal line, which intersects Room Heat Loss Line A at approximately 37°F. This is a reasonable estimate of the maximum uncontrolled heat gain that can be received in the typical classroom from these common heat sources.

### **The Analysis**

From [Figure 67 on page 80](#) it is evident that, at an outside temperature of 48°F or higher, the heat given off by 30 students and classroom lighting is sufficient to cause overheating. This is true even if the classroom is occupied at night when solar heat gain is not a factor. But, since classrooms are occupied during the day, solar addition provides heat in varying amounts even in classrooms with north exposures. Consequently, the heating and ventilating system in our typical classroom must provide cooling at all times when the outdoor temperature is above 48°F and at any time during colder weather when the solar heat gain exceeds room heat loss.

If we assume an average winter temperature of approximately 33°F in the region where our typical classroom is located, we know that, half of the time, both night and day, the outside temperature will be above 33°F. However, since it is generally warmer during the day, when school is in session, the heating and ventilating system will be required to provide cooling for this classroom during much of the time that the room is occupied.

In this example, we've assumed that our classroom had a room heat loss of 55,000 BTU/HR at a design outdoor air temperature of 0°F (Room Heat Loss Line "A").

Bear in mind, however, that the recent trend in "energy-saving" building design often results in rooms with lower room heat loss, as indicated by Room Heat Loss Lines "B," "C" and "D." At 0°F design outdoor air temperature:

- Room "B" has a room heat loss of 45,000 BTU/HR,
- Room "C" has a room heat loss of 35,000 BTU/HR,
- Room "D" has a room heat loss of 25,000 BTU/HR.

Note the lowering of the temperature above which cooling will always be required as the room heat loss decreases.

We've noted that cooling is always required in Classroom "A" when outdoor air temperatures exceed 48°F. In Classroom "B," "C," and "D" cooling is always required when outdoor temperatures exceed 44°, 36° and 23°F, respectively ([Figure 67 on page 80](#)).

Now that we understand the reason for classrooms overheating, the solution is simple: The heating and ventilating system must provide cooling to take care of the heat given off in the classroom by uncontrolled heat sources.

### **Cooling The Classroom**

The Daikin Unit Ventilator has become a standard for heating and ventilating systems in schools because it provides the solution for overheating classrooms. The unit ventilator cools as well as heats. During the heating season the outdoor air temperature is nearly always below the desired room temperature. It stands to reason then that the outside air should be used to provide the cooling necessary to keep classrooms down to thermostat temperature.

The classroom unit ventilator does just that. By incorporating an automatically controlled outdoor air damper, a variable quantity of outdoor air is introduced in the classroom, metered exactly to counteract overheating. Since our problem is more one of cooling than of heating, it is evident that more than just the room heat loss must be determined to design a good heating and ventilating system. The cooling requirements should be assessed as well, and the free-cooling capacity of the equipment specified along with the heating capacity required. If this is done, the optimum learning temperature can be maintained in each classroom.

## Meeting IAQ Requirements

Good indoor air quality (IAQ), which is important in the home and at work, is no less important to students and faculty in schools. For the past several years, efforts to reduce energy costs in new school buildings have seen the use of tighter construction, sealed windows and heavier insulation. While these construction techniques have helped reduce energy costs, tightly sealed buildings, or envelopes, when combined with increased use of recirculated air, have led to a condition known as sick building syndrome.

In a poorly ventilated school building, fumes and vapors from plastics and other synthetics are often not properly exhausted, while mold, fungus, and bacteria are able to flourish. These conditions can cause various ailments, including nausea, smarting eyes, and coughing, as well as increased student absenteeism and diminished productivity.

For these reasons, the American Society of Heating, Refrigeration and Air Conditioning Engineers (ASHRAE) now has recommendations for minimum ventilations rates for various types of classrooms and no longer endorses the practice of little or no usage of outdoor air.

## Following ASHRAE Control Cycle II

ASHRAE Cycle II is a very economical sequence of control because only minimum amounts of outdoor air are heated and free outdoor air—natural cooling—is available to offset the large internal heat gain associated with the dense occupancy of classrooms.

Daikin unit ventilators are normally controlled according to ASHRAE Control Cycle II. ASHRAE control cycles apply only to heating, heating-and-ventilating and free-cooling operation. (For more information on the ASHRAE Control Cycle II sequence, see [page 87](#).)

Under ASHRAE Cycle II, the outdoor air damper is closed during warm-up of the room. As the room temperature approaches the thermostat setting, the outdoor air damper opens to a predetermined minimum percentage of outside air. The heating coil capacity controller then modulates to maintain the thermostat setting.

If the room temperature rises above the thermostat setting, the heating coil is turned off and the outdoor air damper opens beyond the minimum position to maintain the thermostat setting.

**EXAMPLE:** For a 60°F entering air mixture temperature and 70°F room temperature, with 30°F outdoor air temperature, 25% outdoor air will produce the 60°F mixture air temperature. When the outdoor air temperature drops to 10°F, 12.5% outdoor air will produce the 60°F mixture air temperature.

## Night Setback

Substantial fuel savings can be realized by operating the unit ventilator system at a reduced room setting at night and during other unoccupied periods, such as weekends and holidays. Units with steam or hot-water coils will provide convective heat during the setback period. If the space temperature falls below the setting of the unoccupied thermostat, the unit fans will be brought on to provide additional heat. Units with electric heat coils do not provide convective heat. The electric coil and the unit fans will be brought on to maintain the thermostat setting.

## Typical Temperature Control Components

In general, unit ventilators require the following basic DDC electrical components in order to operate on any of the standard unit ventilator ASHRAE cycles of control. The control components listed in this section are for familiarization purposes only and should not be construed as a bill of material.

### **Outdoor Air Damper Actuator**

This is a modulating device under the control of the room and discharge sensors. It positions the outdoor air damper to admit the amount of outdoor air required at any given point in the control cycle. The room air damper is mechanically linked to the outdoor air damper, which permits the use of a single actuator. Electric actuators should be of the spring-return type so that the outdoor air damper closes whenever the electric power supply to the unit is interrupted.

### **Discharge Airstream Sensor**

This device overrides the room sensor and modulates the outdoor air damper toward the closed position when the unit discharge air falls to a potentially uncomfortable temperature.

### **Temperature Modulation Devices**

The temperature of the air entering the room is modulated using one or more of the following devices:

**Face and Bypass Damper Control:** A modulating damper actuator, under control of the room sensor, positions a face and bypass damper to control the amount of air that passes through or around the unit coil.

**Valve Control:** A modulating valve, under control of the room sensor, regulates the flow of steam or hot water through the unit coil.

**Electric Heat Step Control:** A modulating step controller, under control of the room sensor, steps individual electric heating elements on and off as required. Staging relays are sometimes used in lieu of a step controller.

### **Room Sensor**

The room sensor is a temperature-sensing device that modulates the intensity of an electric signal to the controlled components within the unit in order to maintain the room sensor's comfort setting. Room sensors can be mounted on the wall or within the unit in a sampling chamber.

### **Additional Components**

Additional components may be required depending on the specific application. They include:

**Sampling Chamber:** This device is required whenever the room sensor is to be mounted within the unit ventilator rather than on the wall. The sampling chamber is located behind a series of holes in the unit front panel. The sensing element of the room sensor is positioned within the sampling chamber. The unit fans draw a representative sample of room air over the sensing element at a relatively high velocity, which is necessary for rapid control response. Sampling chambers are furnished with MicroTech controls.

**Low Temperature Protection:** A low temperature limit or freezestat senses the discharge air temperature off the hydronic coil. If the temperature drops below 38°F, the unit ventilator will shut down, closing the outdoor air damper and opening the heating valve.

**DX Cooling Control:** This sequence switch in the cooling control circuit energizes the condensing unit contactor on a call for mechanical cooling.

**DX Cooling Low Ambient Lockout:** This lockout must be used on DX split systems to lock out the condensing unit when the outdoor air temperature is below 64°F (17.5°C). This device must be integrated into the control system so that the unit has full ventilation cooling capability during the lockout period.

**DX Low Temperature Limit:** This limit must be used on DX split system cooling units to de-energize the condensing unit (compressor) when the refrigerant falls below freezing. DX units with MicroTech controls have a factory-installed sensor across the leaving side of the DX coil that provides a representative sample of the coil's temperature.

# Face & Bypass Temperature Control

## Precise Environment Control

Face and bypass damper control units utilize standard unit ventilator cycles of temperature control and bring in up to 100% fresh outdoor air for ventilation (free) cooling

of the classroom. The bypass damper allows all air to pass through the heating coil for fast warm-up. A portion passes through the coil and a portion bypasses the coil when less heat is required. All air bypasses the coil when “free” cooling or no heating is required.

Figure 68: Face & Bypass Temperature Control

<p><b>Morning Warm-Up/Cool Down</b></p> <p><b>Figure A</b> shows the face and bypass damper, the room air damper, and the outdoor air damper positioned for “morning warm-up/cool-down.” During the summer the unit is cooling; in winter it is heating. When the room air temperature is above (cooling) or below (heating) the sensor setpoint, the face and bypass damper is open to the coil. At the same time, the outdoor air damper is closed and the room air damper is open. All air handled by the fan passes through the coil for maximum heating or cooling.</p>	<p><b>A</b></p> <p><b>100% Room Air</b></p>
<p><b>Maximum Heat or Cool, Minimum Outdoor Air</b></p> <p><b>Figure B</b> shows the damper positions as the room temperature approaches the room thermostat setting. The outdoor air damper is open to the minimum setting and the room air damper closes slightly. Unit ventilators normally admit the same minimum percentage of outdoor air during the mechanical cooling cycle as during the heating cycle..</p>	<p><b>B</b></p> <p><b>Minimum Outdoor Air</b></p>
<p><b>Minimum Outdoor Air, Face &amp; Bypass Damper Modulation</b></p> <p><b>Figure C</b> shows normal operation. Room temperature is maintained within the operating range. Under these conditions, the outdoor air and room air dampers retain their same positions while the face and bypass damper modulates to provide accurate room temperature control.</p>	<p><b>C</b></p> <p><b>Minimum Outdoor Air</b></p>
<p><b>Full Outdoor Air (Free Cooling)</b></p> <p><b>Figure D</b> shows the damper positions for maximum ventilation cooling. When uncontrolled heat sources tend to overheat a room (such as people, lights or sunlight), the face and bypass damper will bypass 100% of the air around the heat transfer element. The end-of-cycle valve (if furnished) will be closed to the coil. The outdoor air damper will position itself for additional outdoor air, up to 100% of the fan capacity, as required by the room cooling needs. As the outdoor air damper opens, the room air damper closes proportionally.</p>	<p><b>D</b></p> <p><b>100% Outdoor Air</b></p>

## Ease Of System Balancing

With face and bypass damper control, the water in the system is constantly circulating, which maintains a desirable head pressure to the pumps. With fluctuating head pressure eliminated, balancing the system can enable the correct quantity of water in all circuits.

## Two Stage Compressors

Our self-contained units with the two-stage compressor will run on lower fan speeds up to 70% of the time, improving comfort through better humidity control and quieter operation, while minimizing issues with over sizing. The unit is designed to operate in low compression mode while in medium and low fan speed. The reduced cooling capacity in the medium and low fan speed will allow the system to run longer at moderate and low load conditions providing better humidity control. When the high capacity is needed the high speed will provide high compression and full capacity cooling.

## Reduced Risk Of Coil Freeze

With face and bypass damper control, there is no change in the flow of water through the coil. Coils that have a constant flow of water—especially hot water—cannot freeze. On valve control units, water left in the heating coils after the modulating temperature control valve shuts can freeze and rupture the coil.

Additional freeze protection is afforded by Daikin's double-walled cold weather outdoor damper. It has encapsulated insulation and wool mohair end seals to help prevent unwanted cold air from entering the unit. This construction method further decreases the chance of coil freeze if water flow is inadvertently interrupted.

A low-temperature freezestat, factory installed on all hydronic units, significantly reduces the chance of coil freeze-up. Its wave-like configuration senses multiple locations by blanketing the leaving air side of the coil to react to possible freezing conditions.

## Modulating Valve Temperature Control

### Modulating Valve Control with Hot Water or Steam

The description of unit operation given for damper controlled units is correct for valve-controlled units except that references to face and bypass dampers and end-of-cycle valves should be disregarded. The capacity of the heating coil will be regulated by a modulating control valve and all air handled by the unit will pass through the heating coil at all times.

### Hot Water Reset

Hot water system controls should include a provision for resetting the temperature of the supply hot water in relation to the temperature of the outdoor air. A hot water temperature of 100°-110°F, is suggested when the outdoor air temperature is 60°F. The upper limit of the hot water temperature will be dictated by the winter design conditions.

Figure 69: Modulating Valve Temperature Control

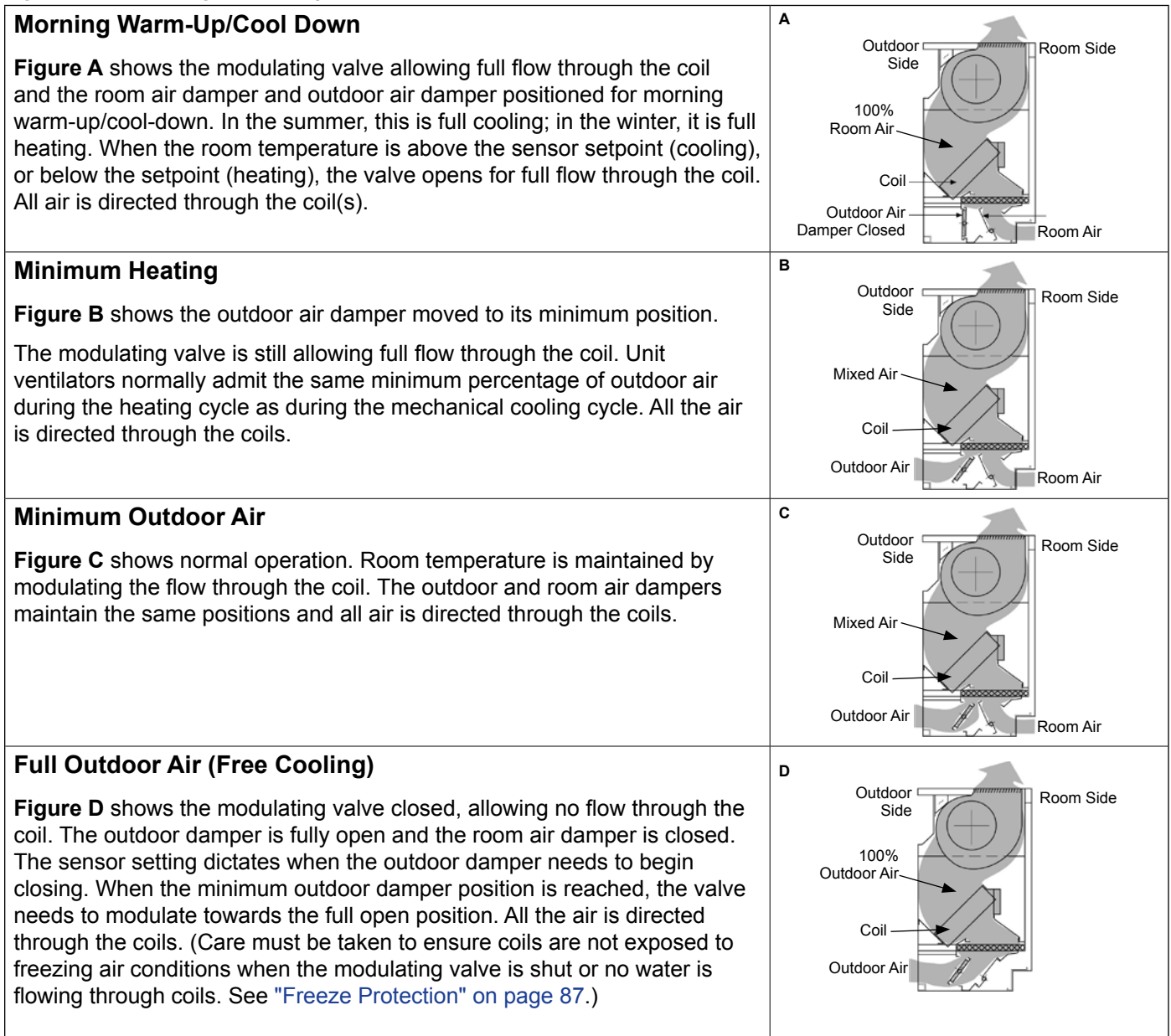

The need for hot water reset controls is not limited to applications involving unit ventilators with face and bypass control. Valve control performance will be improved as well. When the supply water temperature is far in excess of that required to offset the heat loss of the space, the smooth modulating effect of the control valve is lost. The control valve will cycle between slightly open and fully closed. The effect of heat conduction through a closed valve will also be reduced when hot water reset is used.

**Freeze Protection**

System freeze protection is an important consideration on units utilizing hydronic coils. On valve-controlled units, water left in the heating coils and exposed to freezing outdoor air after the modulating valve shuts can freeze and rupture the coil. Flowing water will not freeze. In addition, it is very important to correctly size the modulating control valve and control the supply water temperature to provide constant water flow. If this situation cannot be guaranteed, an antifreeze solution must be employed to reduce the possibility of coil freeze.

**Coil Selection**

An extensive choice of coil offerings means that, with Daikin unit ventilators, room conditions can be met using almost any cooling or heating source. All coils are located safely beneath the fans and are designed for draw-thru air flow. All coils have their own unshared fin surfaces (some manufacturers use a continuous fin surface, sacrificing proper heat transfer). The result is maximum efficiency of heat transfer, which promotes comfort and reduces operating costs.

An air break between coils in all Daikin units is used to enhance decoupling of heat transfer surfaces—providing full capacity output, comfort and reduced operating costs.

All water, steam and direct expansion (DX) coils are constructed of aluminum fins with a formed, integral spacing collar. The fins are mechanically bonded to the seamless copper tubes by expansion of the tubes after assembly. Fins are rippled or embossed for strength and increased heat transfer surface.

**High-Quality Water Coils**

Daikin Applied coils rely on advanced heat transfer to provide extra heating capacity for today’s increased ventilation requirements. Tuned internal flow and a balanced header design, together with additional surface area in the air stream, increase heat transfer to satisfy the increased need for heat.

A manual air vent is located on the top of the coil header of all floor hydronic coils. (Figure 70). This allows air to be purged from the coil during field start-up or for maintenance.

A manual drain plug (Figure 70) is provided at the bottom of the coil header for coil drainage. Some competitors may not provide for drainage of coils.

**Figure 70: Manual Air Vent & Drain Plug**

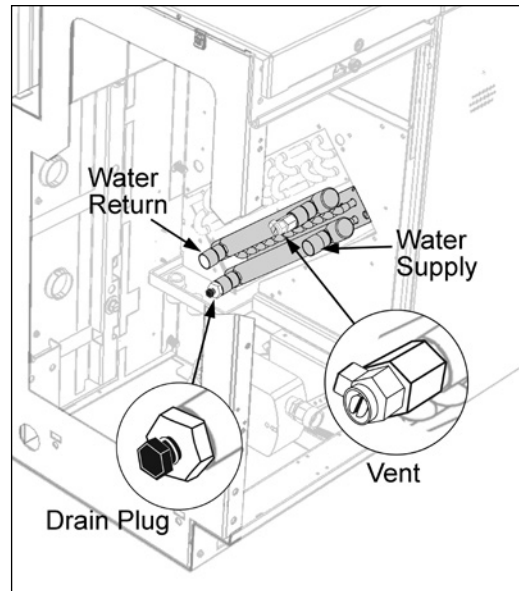

**Long Lasting Electric Heating Coils**

With our draw-thru design, electric coils are directly exposed to the air stream. They come with a built-in switch to de-energize the coil when the center front panel is removed. A unit-mounted disconnect switch is included. A continuous electric sensory element for high temperature is not required because the air is drawn smoothly and evenly across the coils, prolonging life. (Blow-thru designs use cal rods inserted into the tube of a fin tube coil that results in reduced heat transfer. The constant movement of the electric heating cal rod within the tube shortens life.)

**Even Distribution Steam Coils With Vacuum Breakers**

Steam distribution coils provide even distribution of steam and even discharge air temperatures. A vacuum breaker relieves the vacuum in the steam coil to allow drainage of condensate. This eliminates water hammer and greatly reduces the possibility of coil freeze-up.

## ASHRAE Cycle II

We strongly recommend that ASHRAE Cycle II be implemented with all unit ventilators using controls by others. ASHRAE Cycle II is a very economical sequence since only the minimum amount of outside air is conditioned and free natural cooling is available.

During warm-up (any classroom temperature 3°F or more below heating setpoint), the outdoor air damper is closed and the unit conditions only room air. As room temperature approaches the heating setpoint the outdoor air damper opens to a position that permits a predetermined minimum amount of outside air to be drawn in. Unit capacity is then controlled as needed to maintain room setpoints. If room temperature rises above room cooling setpoint, and the outside air is adequate for economizer cooling, then the outdoor air damper may open above the minimum position to provide economizer cooling.

ASHRAE Cycle II requires that a minimum of three temperature measurements be made:

1. Classroom temperature.
2. Unit discharge air temperature.
3. Outdoor air temperature.

Additionally, the control sequence should incorporate a Discharge Air Low Limit function which requires a discharge air temperature sensor and can override classroom temperature control in order to maintain a discharge air temperature setpoint of 55°F.

When the discharge air temperature drops below 55°F, the discharge-air low-limit function will disable cooling (if enabled) and modulate the unit's heating capability as needed to maintain the 55°F discharge-air setpoint regardless of room temperature.

If the unit's heating capability reaches 100%, then the discharge air low-limit function will modulate the outdoor air damper toward closed to maintain the 55°F discharge air setpoint. Outdoor air temperature is used to determine when to use economizer as a first stage of cooling, and when to use mechanical or hydronic cooling as the first stage of cooling.

Figure 71: ASHRAE Cycle II Operation

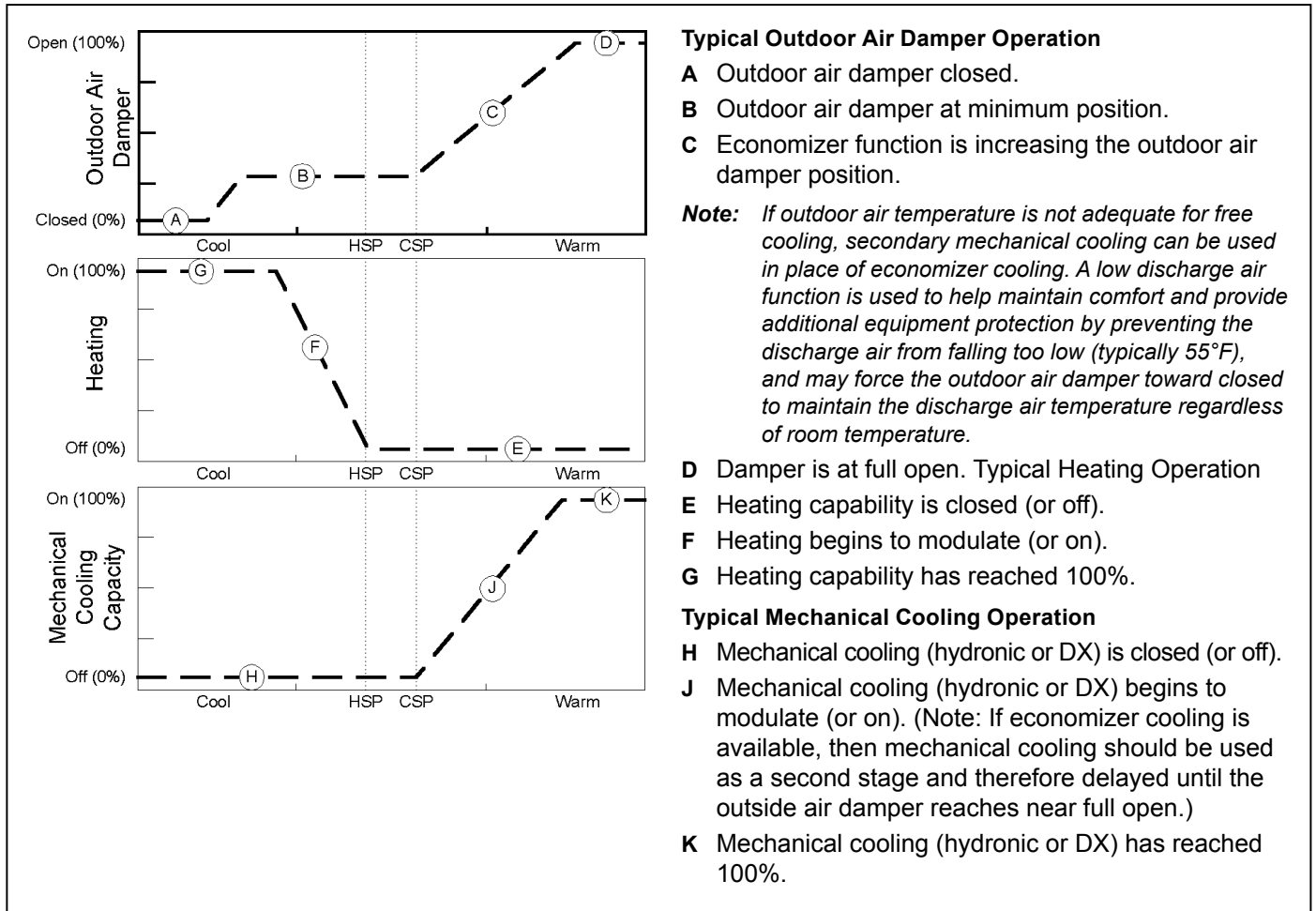



## End-Of-Cycle (EOC) Valve Operation

The intended purpose of an EOC valve is to reduce the chances of conductive radiant overheating which can occur when the face and bypass damper is in the full bypass position (i.e., no heating).

A heating EOC valve must be used on units with DX cooling coupled with steam or hot water heat and face and bypass damper temperature control. It is optional for the remaining models. However, it is strongly recommended that heating or heat/cool EOC valves be used on all face and bypass units with heating capability to prevent overheating.

### Heating EOC Valve

For steam or hot water heat only with face and bypass damper control; steam or hot water heat with face and bypass damper control coupled DX cooling:

The heating EOC valve should be a normally open, spring return (open), two position valve. In addition:

- 1 Heating Operation:** When the room temperature is 2°F or more below the heating setpoint, the EOC valve should open and remain open until the room temperature becomes equal to the heating setpoint or higher.
- 2 Operation Due To Outside Air Temperature:** If the outside air temperature is equal to or less than 35°F, the EOC valve should open, the EOC should then remain open until the outdoor air temperature reaches 37°F. or higher.

## Water Coil Low Air Temperature Limit (Freezestat) Operation

The Water Coil Low Air Temperature Limit, or freezestat, function is intended to help protect the water coil from extremely low air conditions. All units with hydronic coils ship with a freezestat. The freezestat has a cut-out temperature setting of no less than 38±2°F and a cut-in temperature setting of approximately 45±2°F. The freezestat is intended as a backup in case the normal operating controls fail to protect the equipment. It is used in the following manner:

### DX Cooling With Hot Water Heat & Face and Bypass Control:

The freezestat is secured to the leaving air face of the hot water heating coil. When the freezestat cuts out due to low temperatures, the following should occur:

- The compressor is de-energized.
- The outdoor air damper is closed.
- The heating EOC valve is forced to full open.
- The face and bypass damper modulates as needed to maintain space temperature.
- When the freezestat cuts in after cut-out, normal operation may return.

## Valve Control Applications

System freeze protection must be considered on valve controlled units utilizing hydronic coils. Non-flowing water in heating coils that are exposed to freezing outdoor air can freeze and rupture the coil (after the modulating valve shuts). The modulating control valve must be correctly sized and the supply water temperature controlled to ensure constant water flow. If this cannot be guaranteed, use an antifreeze solution to eliminate the possibility of coil freeze.

### DX Cooling With Hot Water Heat & Valve Control:

The freezestat is secured to the leaving air face of the hot water heating coil. When the freezestat cuts out due to low temperatures, the following should occur:

- The compressor (condensing unit) is de-energized.
- The outdoor air damper is closed.
- The unit fan is de-energized.
- The heating valve is forced to full open.
- When the freezestat cuts in after cut-out, normal operation may return.

## Unit Installation

Carefully arrange the location and installation of each model AZ unit to provide convenient service access for maintenance and, if necessary, removal of the unit. The installation consists of four basic elements in the following order:

- 1 Louver
- 2 Galvanized Wall Sleeve
- 3 Horizontal Air Splitters by others (if required)
- 4 AZ Self-contained Unit Ventilator

The louver brings in outdoor air for the condenser fan section and ventilation air to the classroom while providing a path for heated condenser air to exit.

The Wall Sleeve secures the unit, provides a watertight and air tight seal to the building and brings in electrical and control wiring (if required). It contains the unit main power disconnect switch which is located in the wall sleeve junction box. All field electrical connections are made inside this box.

Horizontal Air Splitters provide proper air paths and minimize air recirculation.

The AZ self-contained unit ventilator provides comfort cooling and heating for the space. The Model AZ unit is designed to be installed into or up against an exterior wall. The louver, air splitters (if required) and wall sleeve are installed before the AZ unit is installed.

On many jobs, the louver and wall sleeve are shipped ahead of the unit itself. Installation instructions for these components are shipped with the individual components included in this publication.

The following are general instructions for suggested applications. In all cases, good engineering practices and local codes must be followed.

**Figure 72: Typical Self-Contained Unit Ventilator Installation**

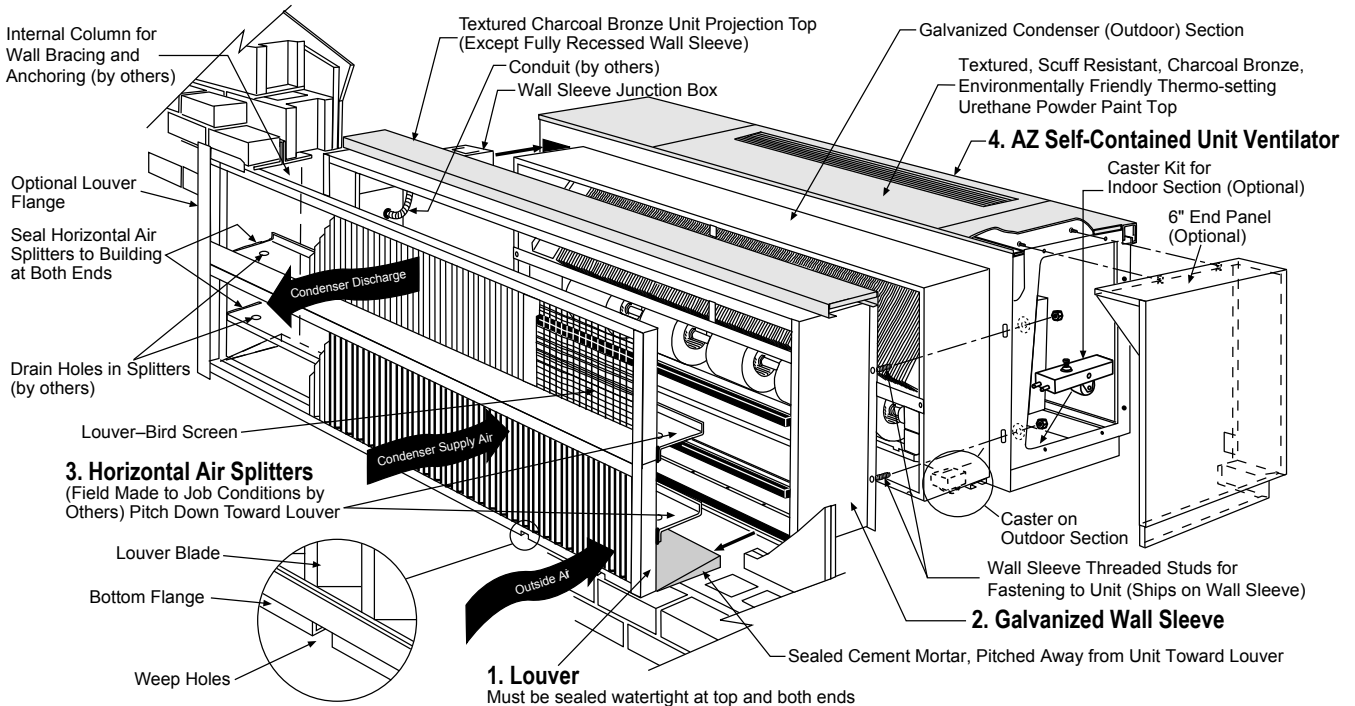

## Wall Louvers

The outdoor air wall louver is usually set directly back of the unit ventilator. The position of the wall louver is determined in general by the building construction. The top of the lower channel of the louver frame should be at least 1/2" below the level of the inlet to the unit ventilator.

However, if a high intake opening is necessary, the top of this opening should be not more than 28" above the surface upon which the unit ventilator will set.

Figure 73: Wall Penetrations Detail

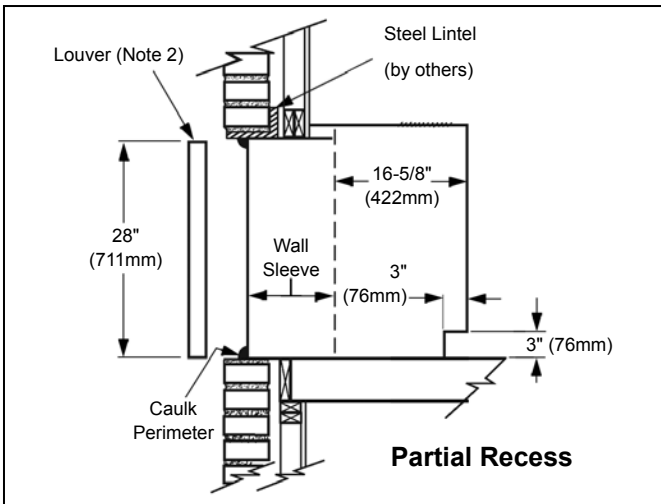
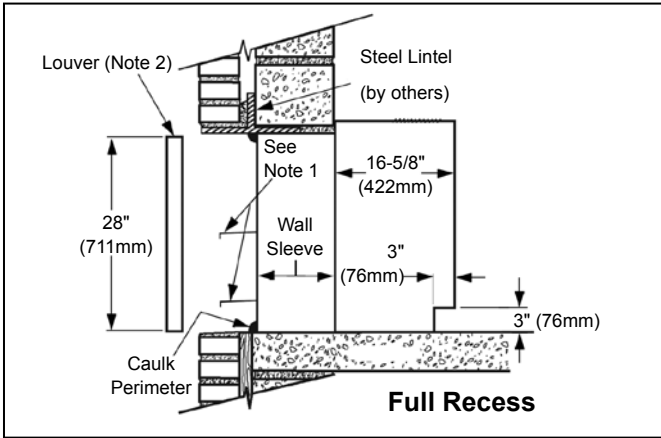

**Notes:**

- 1 Horizontal splitter (by others) must be installed whenever there is any space between the wall sleeve and the louver. It is necessary to seal the ends of the wall opening.
- 2 The top and two sides of the louver must be caulked water tight. The bottom edge of the louver must not be caulked, to allow for drainage.
- 3 Louvers may be recessed a maximum of 2" (51mm) from the exterior face of the wall.

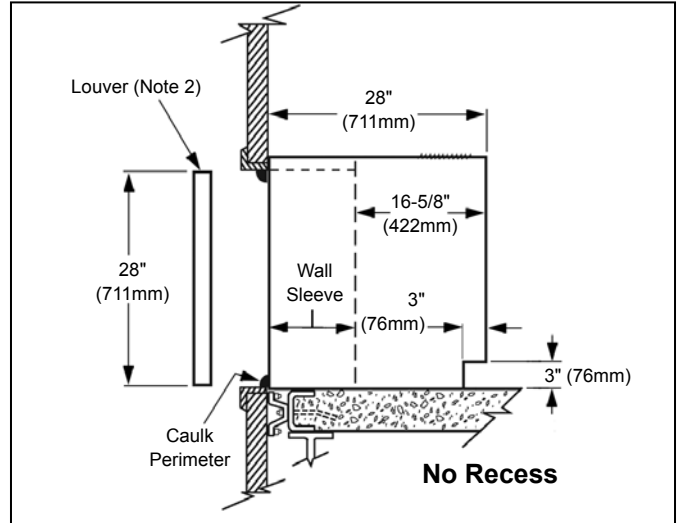

- 4 Drain must be flush with floor to allow unit installation and removal. Unit drain tube is 7/8" (22mm) O.D. copper.
- 5 A field-supplied air seal should be applied to the exterior perimeter of the wall sleeve when unit is installed with no recess.

## Lintels

When brickwork is built up to the top of the intake, lintels must be used above the wall louvers. While the wall is still wet, finish the brick on the top, bottom and both sides of the intake opening with 1/2" cement mortar. With the standard location of the wall louver, the bottom of the intake opening must slope from the louver frame up toward the intake opening to a point 1" above the finished base of the unit.

If a metal sleeve connection is to be used between the unit ventilator and the wall louver, this sleeve must be installed after the unit ventilator is set, making a weather-tight connection to the unit ventilator cabinet. Turn the sleeve over the edge of the louver frame by proper peening before the louver is finally installed.

Figure 45: Typical Wall Opening with Lintels

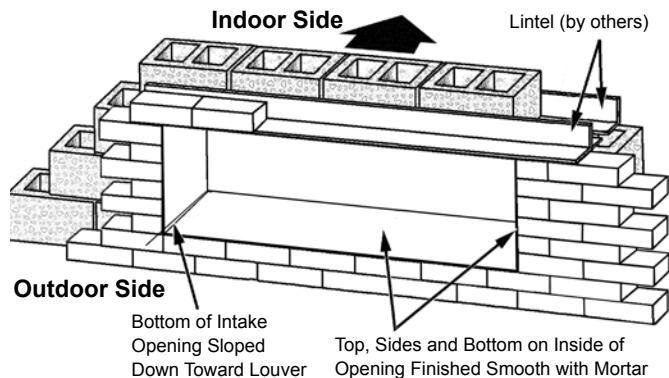



### Interior Considerations

The interior wall surface behind the unit ventilator must be smooth and level. A wall that is slightly out of plumb can cause major problems with outside air leakage into the room and unit. This could cause drafts and potentially freeze coils.

Be certain that no gap is left between the unit and the outside air louver opening. Otherwise, outside air can leak into the room.

A rubberized, self-adhering membrane around the outside air opening can be used to seal any air or water leaks that might result from construction. Provide a seal under the unit to prevent air infiltration. In addition, seal the unit top and side perimeters to prevent unnecessary air infiltration due to uneven walls.

### Indoor Air Exhaust Considerations

All outdoor air introduced by the unit ventilator must leave the room in some way. In some states, exhaust vents are required by law. In states where vents are not required by law, a decision must be made about how best to handle this problem.

The venting system chosen should have the ability to exhaust varying amounts of air equal to the amount of outside air introduced by the floor unit ventilator. A constant volume system, such as a powered exhaust, is unable to respond to changing conditions. It will either exhaust too much air, resulting in a negative pressure, which draws in more outdoor air than desired. Or, it will exhaust too little air, resulting in increased positive pressure, which restricts the amount of outside air being brought into the room.

The Daikin Ventimatic shutter is a more economical solution to the problem. See "[VentiMatic Shutter Room Exhaust Ventilation](#)" on page 23 for information on this system and its proper installation.

## Wall Sleeve Arrangements

Figure 78: Recessed Wall Sleeve with Horizontal Air Splitters

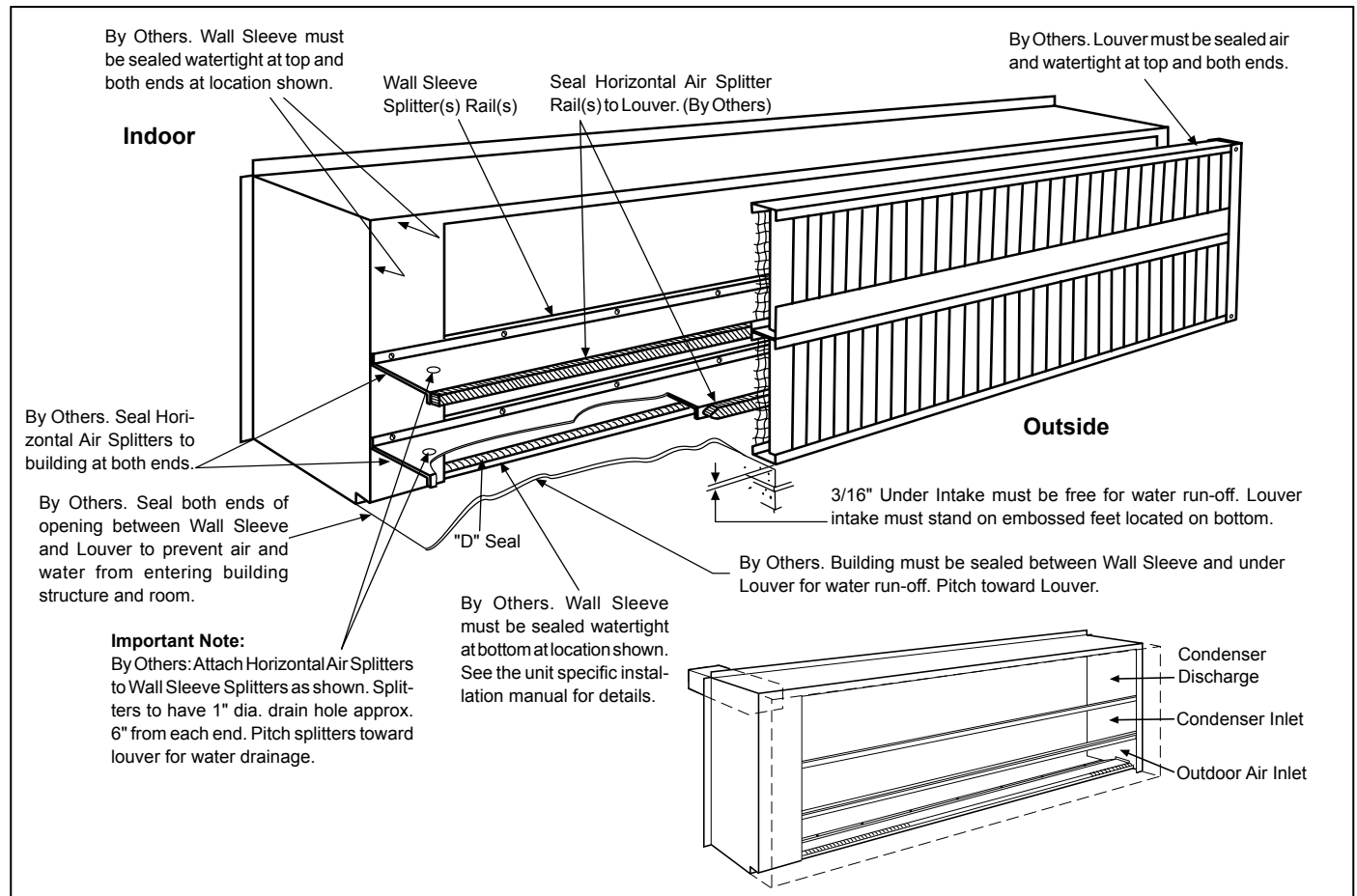

**Figure 79: Sealing Full Projection Wall Sleeve and Horizontal Air Splitters**

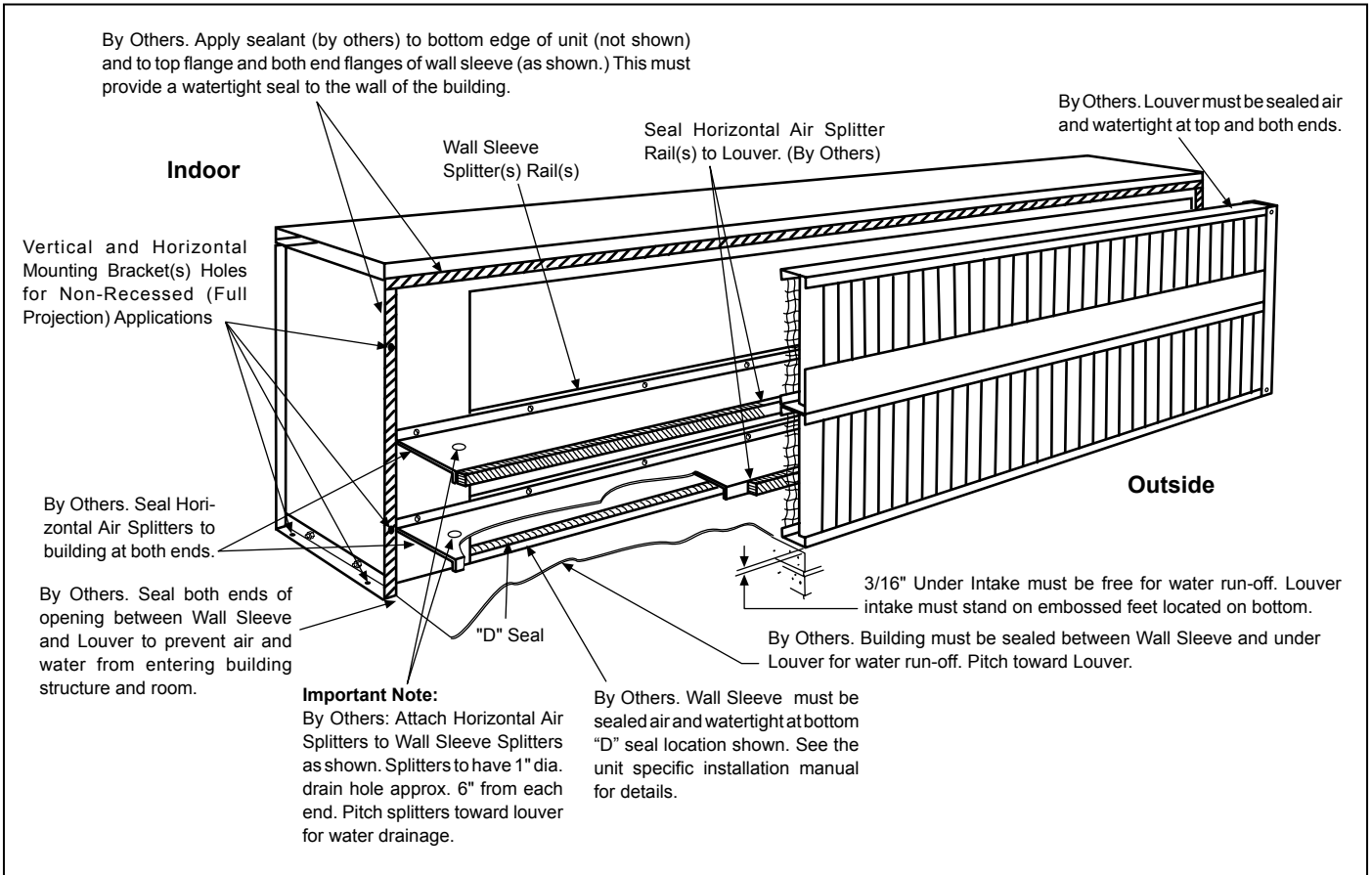

**Figure 80: Recessed Wall Sleeve - Direct Sealing Wall Sleeve to Louver**

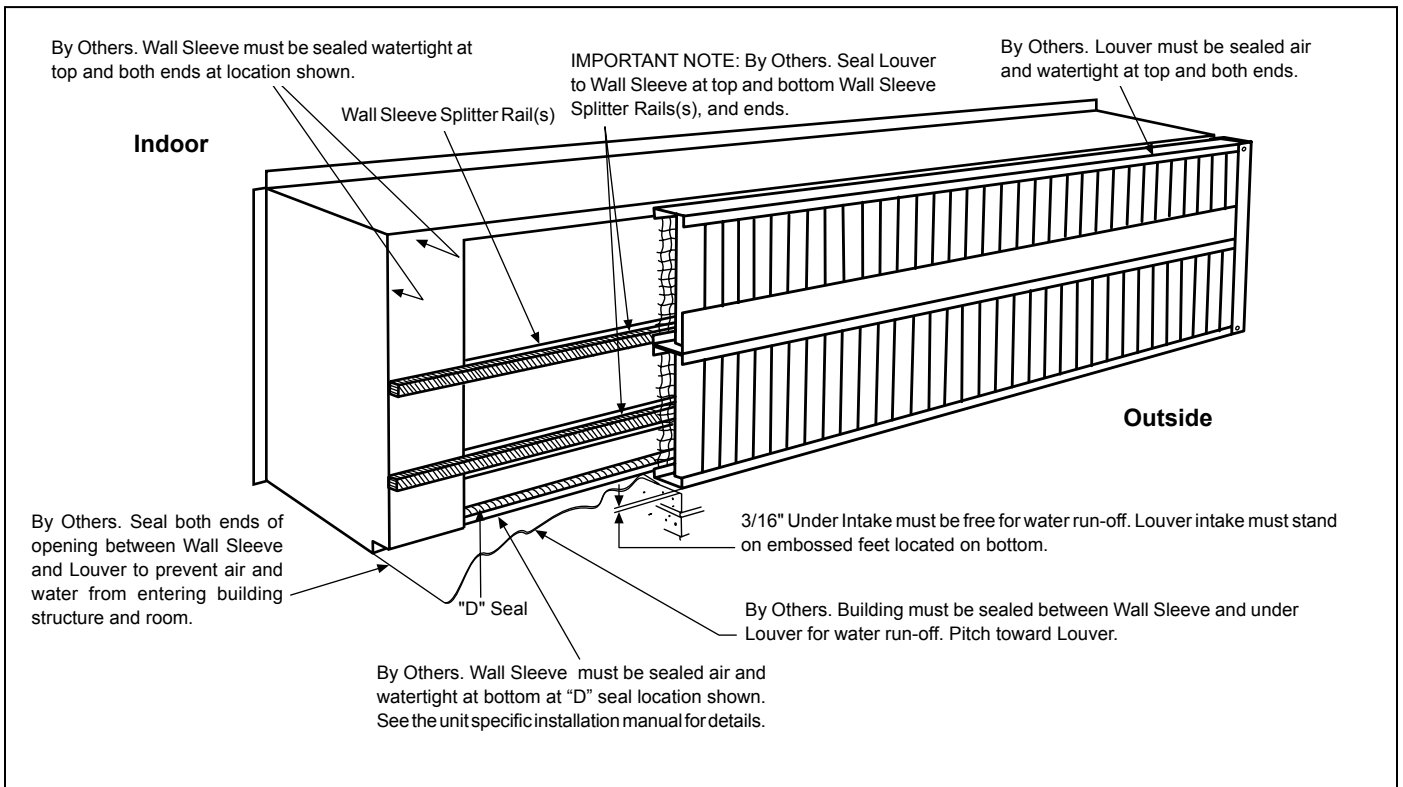

**Figure 81: Sealing Full Projection Wall Sleeve to Louver Intake Without Horizontal Air Splitters**

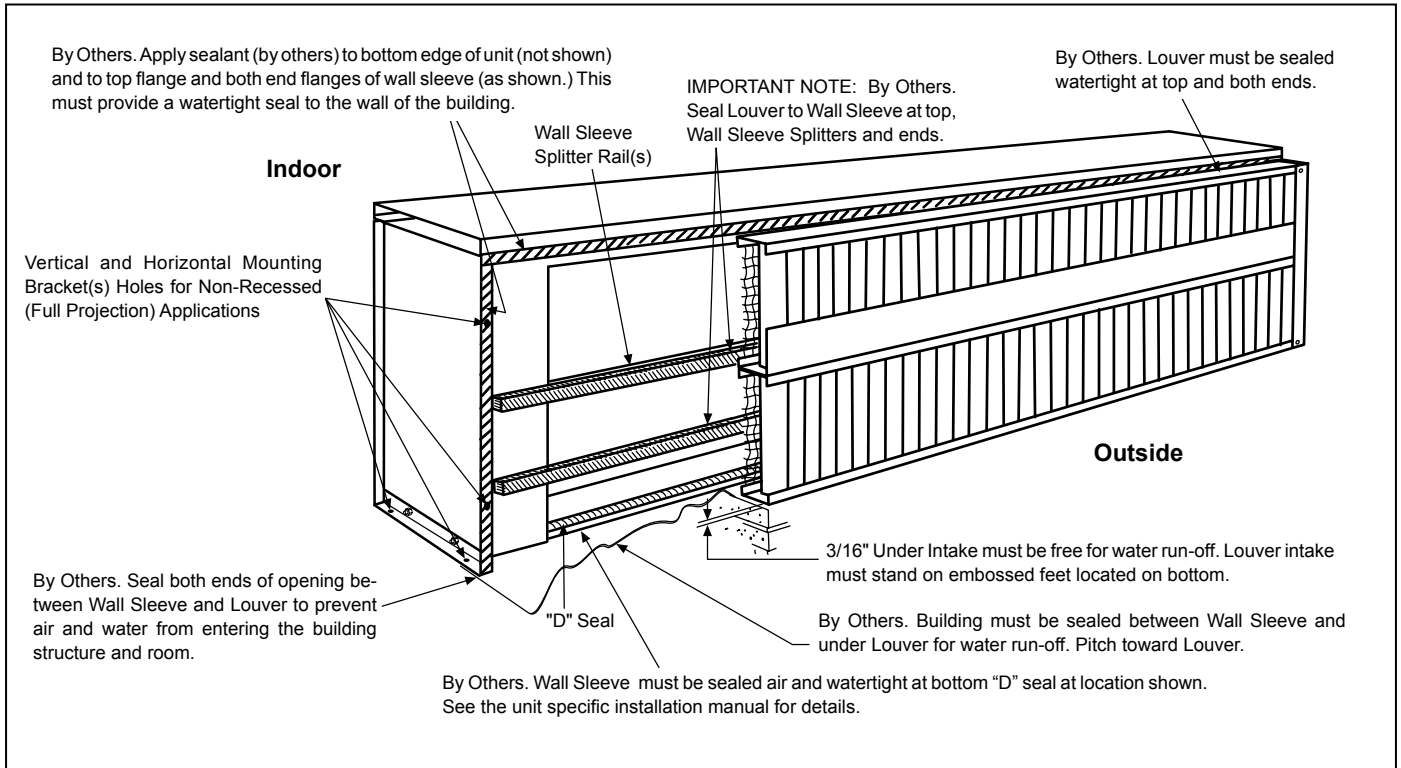

**Figure 82: VentiMatic Shutter Installation**

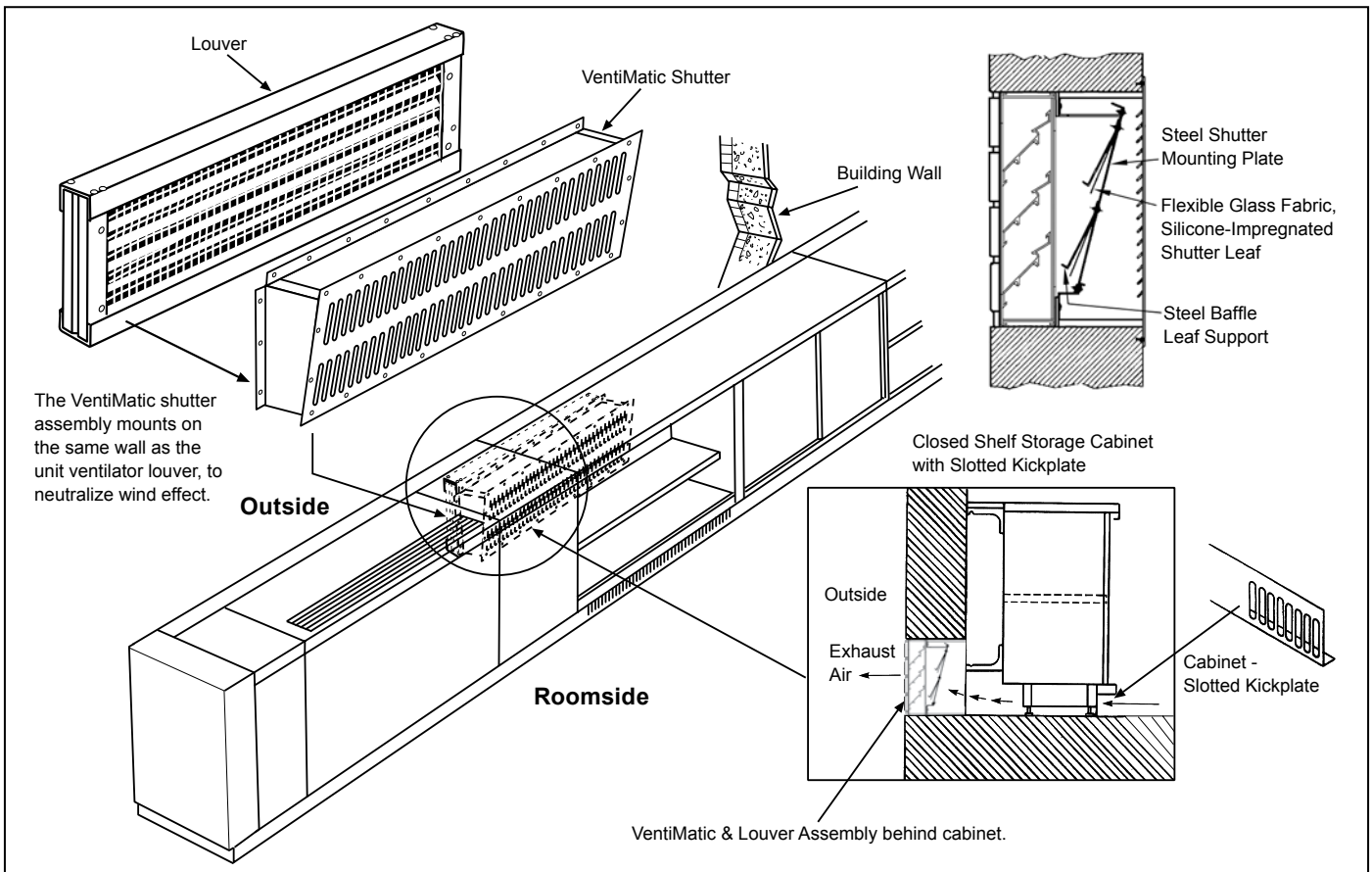

## Valve Selection

### Face and Bypass End-Of-Cycle Valve Sizing & Piping

**Note:** Piping packages can be purchased from Daikin or provided by others

MicroTech face and bypass damper control requires an end-of-cycle (EOC) valve for each hydronic coil. End-of-cycle (or two position) valves are either full-open or full closed. To select an end-of-cycle valve:

1. Determine the flow of water and the corresponding pressure drop through the coil.

2. Obtain the pressure difference between the supply and return mains.
3. Select a valve (Cv) on the basis of taking 10% of the available pressure difference (at design flow) between the supply and return mains at the valve location. The valve should have a pressure drop less than or equal to that of the coil.

Table 41 gives the pressure drops at various water flow rates for the Cv of the valve listed. EOC valves for water applications can be either two-way or three-way.

Refer to the EOC valve label to determine the direction of flow. The EOC valve must be installed on the unit for which it was selected.

**Table 41: Hot Water End-Of-Cycle Valve Selection By Pressure Drop**

Cv	Connection Size	GPM	Valve Pressure Drop at Listed Water Flow Rate															
			5	6	7	8	9	10	11	12	13	14	15	16	17	18	19	20
			L/s	0.32	0.38	0.44	0.50	0.57	0.63	0.69	0.76	0.82	0.88	0.95	1.01	1.07	1.14	1.20
<b>3-Way Hot Water EOC Valve, FNPT</b>																		
5.0	3/4 inch	ft H2O	2.3	3.3	4.5	5.9	7.5	9.2	11.2	13.3	15.6	18.1	20.8	23.6	26.7	29.9	33.3	36.9
		kPa	6.9	9.9	13.5	17.7	22.3	27.6	33.4	39.7	46.6	54.1	62.1	70.6	79.7	89.4	99.6	110.3
<b>2-Way Hot Water EOC Valve, FNPT, Normally Open</b>																		
7.5	3/4 inch	ft H2O	1.0	1.5	2.0	2.6	3.3	4.1	5.0	5.9	6.9	8.0	9.2	10.5	11.9	13.3	14.8	16.4
		kPa	3.1	4.4	6.0	7.8	9.9	12.3	14.8	17.7	20.7	24.0	27.6	31.4	35.4	39.7	44.2	49.0

### Hot Water EOC Valve Piping

Hot water EOC valves are furnished normally open to the coil. When the valve is de-energized (off) there is full flow through the coil. Energizing the valve shuts off the water flow.

**Figure 83: 2-Way Hot Water EOC Valve Piping**

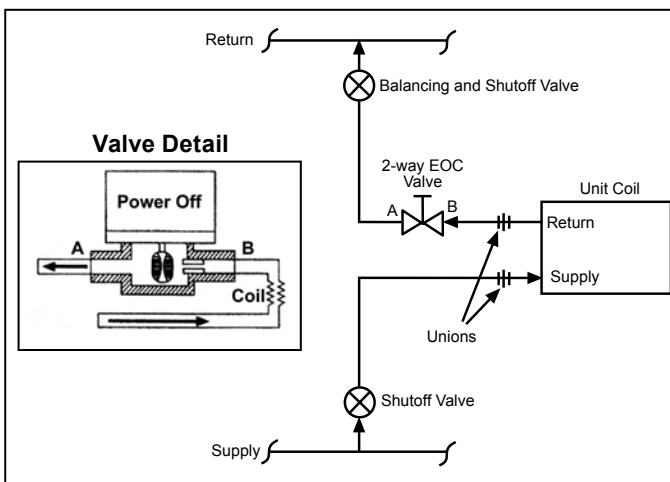

**Figure 84: 3-Way Hot Water EOC Valve Piping**

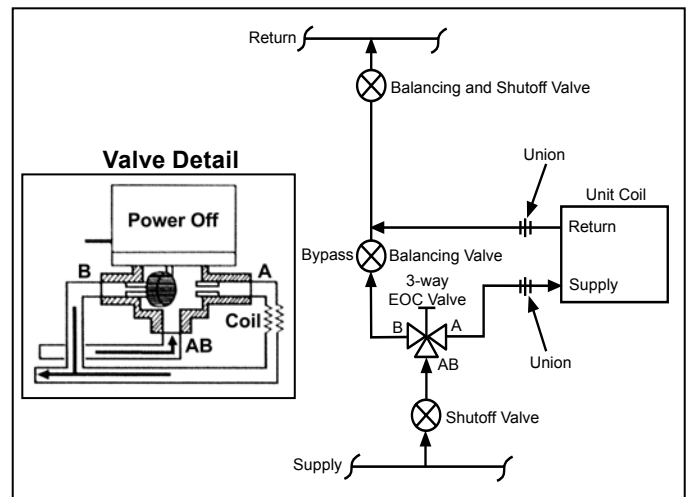



## Modulating Valve Sizing & Piping

The unit ventilator control valve is expected to vary the quantity of water that flows through the coil in a modulating fashion. Movement of the valve stem should produce a controlled change in the amount of water that flows through the coil. When control valves are oversized (Cv too high) the flow relative to valve position is not linear. For example, assume that, when the control valve is fully open, the pressure drop through the coil is twice as great as the drop through the valve. In this case, the control valve must travel to approximately 50% closed before it can begin to have any influence on the water flow through the coil. The control system, no matter how sophisticated, cannot overcome this. Oversized control valves can also result in hunting which will shorten the life of the valve and actuator and possibly damage the coil. Undersized (Cv too low) control valves will accurately control the flow but will have a very high pressure drop through the valve.

To correctly select the modulating valve:

1. Determine the flow of water and the corresponding pressure drop through the coil.
2. Obtain the pressure difference between the supply and return mains.
3. Select a valve (Cv) from [Table 42](#) or [Table 43](#) on the basis of taking 50% of the available pressure difference (at design flow) between the supply and return mains at the valve location. The valve should have a pressure drop greater than that of the coil. Whenever possible there should be at least 11 feet of water (5psi) (32.9 kPa) pressure drop across the valve.

Modulating valves for water applications can be either 2-way or 3-way. Refer to the modulating valve label to determine the direction of flow. The modulating valve must be installed on the unit for which it was selected.

The modulating valve furnished for steam applications is a 2-way, normally open to the coil configuration (see "[Steam Valve Sizing & Piping](#)" on page 98 for application).

**Table 42: 2-Way Modulating Valve - Pressure Drop**

2-Way CCV Part No.	Cv Maximum Rating	Connection Size	Pressure Drop Across the Valve									
			1 PSI	2 PSI	3 PSI	4 PSI	5 PSI	6 PSI	7 PSI	8 PSI	9 PSI	10 PSI
B209	0.8	1/2 inch	0.8	1.1	1.4	1.6	1.8	2.0	2.1	2.3	2.4	2.5
B210	1.2		1.2	1.7	2.1	2.4	2.8	2.9	3.2	3.4	3.6	3.8
B211	1.9		1.9	2.7	3.3	3.8	4.2	4.7	5.0	5.4	5.7	6.0
B212	3.0		3.0	4.2	5.2	6.0	6.8	7.3	7.9	8.5	9.0	9.5
B213	4.7		4.7	6.6	8.1	9.4	11	12	12	13	14	15
B214	7.4		7.4	10	13	15	17	18	20	21	22	23

**Table 43: 3-Way Modulating Hot Water Valve - Pressure Drop**

2-Way CCV Part No.	Cv Maximum Rating	Connection Size	Pressure Drop Across the Valve									
			1 PSI	2 PSI	3 PSI	4 PSI	5 PSI	6 PSI	7 PSI	8 PSI	9 PSI	10 PSI
B309(B)	0.8	1/2 inch	0.8	1.	1.4	1.6	1.8	2.0	2.	2.3	2.4	2.5
B310(B)	1.2		1.2	1.7	2.	2.4	2.8	2.9	3.2	3.4	3.6	3.8
B311(B)	1.9		1.9	2.7	3.3	3.8	4.2	4.7	5.0	5.4	5.7	6.0
B312(B)	3.0		3.0	4.2	5.2	6.0	6.8	7.3	7.9	8.5	9.0	9.5
B313(B)	4.7		4.7	6.6	8.1	9.4	11	12	12	13	14	15
B318(B)	7.4		7.4	10	13	15	17	18	20	21	22	23

### Hot Water Modulating Valve Piping

The optional 2-way modulating hot water valve is furnished to fail open to the coil. 24VAC is required to power the valve actuator. When the actuator is powered, a controller will provide a 2-10VDC signal to the actuator. A signal of 2VDC or less will drive the valve closed; the valve will drive open as the signal increases to a maximum of 10VDC.

If 24VAC is lost to the actuator, valve will spring-return to its fail position (open to the coil for hot water valves).

**Figure 85: 2-Way Hot Water Modulating Valve Piping**

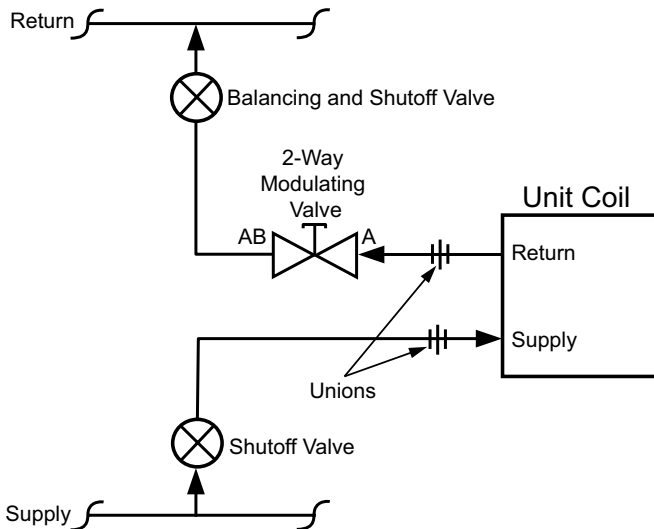

**Figure 86: 3-Way Hot Water Modulating Valve Piping**

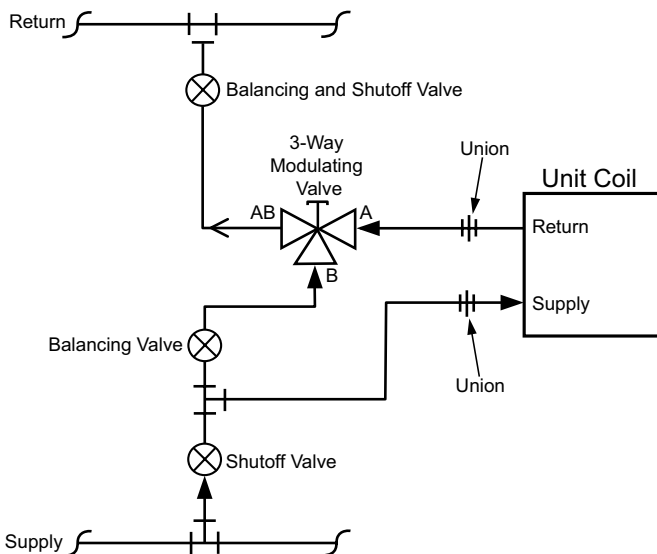

**Note:** The A port must be piped to the coil to maintain proper control.

### Steam Valve Sizing & Piping

#### End-Of-Cycle Steam Valve Selection

End-of-cycle steam valves are either full-open or full-closed. To select an end-of-cycle steam valve:

1. Obtain the supply steam inlet pressure.
2. Determine the actual heat requirement of the space to be heated.
3. Select a steam valve (Cv) based on taking 10% of the inlet steam pressure. For example, for a system with an inlet pressure of 2 psig, the valve should be sized based on a 0.2 psig pressure drop. The valve must have a capacity greater than or equal to that of the space to be heated.

Table 44 gives the steam capacity based on a pressure drop equal to 10% of the inlet pressure.

**Table 44: EOC Steam Valve Selection**

Cv	Connection Size	psig	1	2	3	4	5	6
		kPa	6.9	13.8	20.7	27.6	34.5	41.4
EOC Steam Valve Selection								
8.00	1 inch	MBH	34.3	50.0	63.0	74.7	85.6	96.0
		Watts	10065	14660	18461	21886	25090	28148

<sup>1</sup> Based on 1150 Btu/lb of steam

#### Modulating Steam Valve Selection

The steam modulating control valve is expected to vary the quantity of steam through the coil. Any movement of the valve stem should produce some change in the steam flow rate. To select a modulating steam valve:

1. Obtain the supply steam inlet pressure.
2. Determine the actual heat requirement of the space to be heated.
3. Select a valve (Cv) from Table 45 on page 99, which gives the capacity range based on a 60% pressure drop at the low end of the range and 100% pressure drop at the high end of the range.

For example: with 2 psig (13.8 kPa) inlet pressure, the valve with port code 4, in the full open position, would have a 1.2 psig (8.3 kPa) pressure drop (60% of 2 psig) at 65 MBH (19,189 watts) and a 2 psig pressure drop at 82 MBH (24,125 watts). The valve should have a capacity less than or equal to the space to be heated.

**Table 45: 2-Way Modulating Steam Valve 1/2" – Pressure Drop**

2-Way CCV Part No.	Cv Maximum Rating	Connection Size	Pressure Drop Across the Valve					
			2 PSI	3 PSI	4 PSI	5 PSI	10 PSI	15 PSI
B215HT073	0.73	1/2"	10.99	13.71	16.11	18.33	28.03	36.74
B215HT186	1.86		22.34	34.93	41.06	46.70	71.42	93.60
B215HT455	4.55		54.65	85.44	100.43	114.24	174.72	228.97
B220HT731	7.31	3/4 inch	110.02	137.27	161.36	183.54	280.70	367.86

### Steam Valve Piping

End-Of-Cycle (EOC) and modulating valves for steam applications are 2-way, fail-open (on loss of 24v power), angle pattern valves. Energizing the EOC valve shuts off the flow of steam to the coil. For modulating valves, a signal of 2VDC or less will drive the valve closed; the valve will drive open as the signal increases to a maximum of 10VDC.

If 24VAC is lost to the actuator, valve will spring-return to its fail position (open to the coil for steam valves). Refer to the steam valve label to determine the direction of flow. The steam valve must be installed on the unit for which it was selected.

All valves are shipped loose to help prevent shipping damage and to provide the installing contractor with maximum flexibility in making the field piping connection. The valves are field piped by others. They are factory wired for field hook-up.

**Notes:**

- 1 Refer to the label furnished on 2-way valves to determine direction of flow through the valve.
- 2 The control valve must be installed on the unit in which it was shipped. Indiscriminate mixing of valves among units can result in valves not properly sized for the desired flow rate.
- 3 The control valve should be installed so that there is 2" (51mm) minimum clearance to remove the actuator from the valve body. Provide unions for the removal of the unit coil and/or control valve. This is a future service consideration.

**Figure 87: 2-Way Steam End of Cycle Valve Piping**

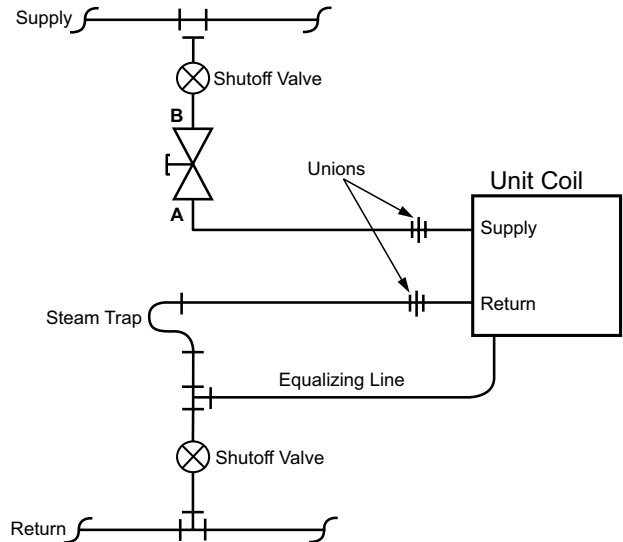

**Note:** For Erie EOC steam valves, always have the direction of steam flow piped to the B port of the valve. Actuator to be configured for B port to be normally open.

**Figure 88: 2-Way Steam Modulating Valve Piping**

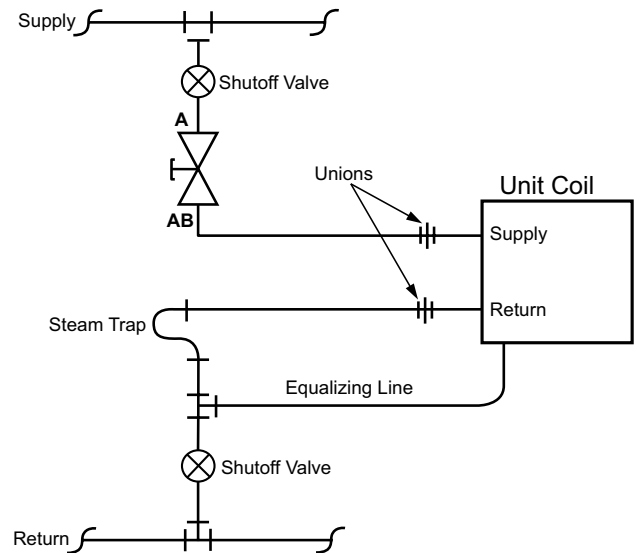

**Note:** For Belimo steam valves, always have the direction of steam flow piped to the A port of the valve. Actuator to be configured for A port to be normally open.

## Daikin Applied Unit Ventilator –Model AZ

### General

Furnish and install where shown on plans, a complete self-contained, air cooled, heating and cooling unit ventilator. This unit shall meet capacities, airflow and configuration as shown on unit schedule.

Each standard unit must be listed by Underwriters Laboratories Inc. (U.L.) as complying with all safety standards.

The units shall ship fully assembled with the exception of the end panels which shall be packaged separately to allow easy access for piping and electrical rough-in. (Option: Wall sleeves shall be shipped in advance of unit for rough-in.)

### Unit Construction

All internal sheet metal parts subject to corrosion must be made of galvanized steel. The entire frame must be welded construction to provide strength and rigidity. Frames assembled with sheet metal fasteners are not acceptable.

### Cabinets

Exterior cabinet panels shall be constructed of heavy gauge steel and every exposed corner must be welded and ground smooth for appearance and durability. All surfaces shall be cleaned and phosphatized, then painted with an oven baked powder paint. Top surface shall be Charcoal Bronze textured powder paint to resist scratching and hide fingerprints. Front access panels and top access door shall be supplied with tamper resistant fasteners.

Removable discharge grille shall be constructed of continuous, round edged, steel bars to provide a 10-degree vertical deflection.

Adjustable side deflection vanes shall be provided beneath the discharge grille to give optimal lateral air distribution. (Option: A 1/4" (6mm) mesh screen shall be provided beneath the discharge grille to protect against objects being dropped through the discharge grille.)

### Room Air Fans and Motor

The motor and fan assembly shall be low speed design and shall be double inlet, forward curved centrifugal type with maximum fan speed of 1100 rpm. Fan wheels shall be constructed of dark, high density, injection molded polypropylene having high impact strength, chemical resistance and thermal stability. Assembly shall be direct drive type and shall be statically and dynamically balanced. Motor shall be permanent split capacitor (PSC) plug-in type located out of the airstream and have an internal thermal overload device (auto-reset). Fan speeds shall be controlled by High-Med-Low-Off switch.

Fan/coil arrangement shall be draw-thru design for uniform coil face velocity and discharge air temperature. Fan motors and controls shall have each hot line protected by factory installed cartridge type fuse(s)

All components of the fan/motor assembly shall be removable from the front of the unit. The motor and fan shaft shall have sleeve type bearings with precision tolerances. Motors shall have permanently lubricated bearings. Fan shaft may have sleeve type bearing that requires oiling no more than once annually. Units requiring oiling will have an oil cap accessed from the left-side end compartment (or on the middle of the fan shaft on size 44MBH and larger). Some units are built with permanently sealed bearings that do not require oiling. Check for coil cap to determine which bearing type is present.

### Condenser Fans and Motors

The fan board and fan housings shall be constructed of galvanized steel. The fan motor and fan shaft shall have permanently lubricated ball bearings. Motor shall be permanent split capacitor (PSC) type. Fan wheels shall be forward curved centrifugal type.

### (Optional) Face and Bypass Damper

Each unit shall be provided with a factory-installed face and bypass damper, constructed of aluminum. The long sealing surfaces of the damper shall seal positively against stops fitted with extruded EPDM rubber seals. Face and bypass damper stops not fitted with seals shall not be acceptable. The damper ends shall have blended mohair seals glued along the ends for a positive seal. Plastic clip-on brush end seals will not be acceptable. The unit design shall incorporate the face and bypass damper to prevent coil surface wiping and be before the fan in a draw through configuration. Face and bypass damper positioned in the direct discharge of the room fan is not acceptable. The face and bypass damper shall be arranged so a dead air space results between the coil and the damper in a full bypass condition to minimize heat pick up.

### Outdoor and Room Air Dampers

Each unit shall be provided with separate room air and outdoor air dampers. The room air damper shall be constructed of aluminum and counterbalanced against back pressure. Outdoor air damper shall be two-piece, double wall construction with 1/2" (13mm) thick, 1.5 lbs. (.68 kg) density fiberglass insulation sandwiched between welded galvanized steel blades. Outdoor air damper shall have additional foam insulation on the exterior of the blades and end partitions. Dampers shall be fitted with blended mohair seals along all sealing edges. Damper bearings shall be made of nylon or other material which does not require lubrication.

## Refrigeration System

The refrigeration section shall be constructed of galvanized steel and shall include a factory sealed, factory piped assembly consisting of a hermetically sealed compressor, a condenser coil, condenser fan and motor, and an evaporator coil. No internal building condensate drain piping system shall be required for condensate removal. Condensate from the indoor (primary) drain pan drains into the (lower) outdoor condenser section drain pan, positioned beneath the condenser fans in the wall-sleeve. Cooling condensate is disposed of when it is directed it into the condenser fan scrolls, which throw the condensate against the hot condenser coils for evaporation. Remaining moisture that does not evaporate is collected in the (upper) outdoor drain pan and routed back to the (lower) outdoor drain pan.

During heavy dehumidification periods, excess condensate that does not evaporate, drains into the (lower) outdoor drain pan and away through the drain notches in the rear flange of the condenser section drain pan, as well as the drain slots at the bottom of the condenser section. With proper wall sleeve opening preparation and unit installation, the excess condensate will flow out the drain notches and follow the slope of the wall sleeve opening and flow under the bottom edge of the louver to the outside. For proper water removal, louvers must be installed with drain notches located at the bottom, and kept free of sealant, mortar and other debris.

The equipment manufacturer is to be fully responsible for the integrity of the refrigerant piping and the entire refrigeration circuit, including compressor. Condenser and evaporator coils shall be fully assembled and tested prior to shipment. The motor compressor unit shall be vibration isolated internally and externally and shall be connected in such a manner as to prevent transmission of vibration to other components within the section.

Single-phase only: Single-phase units shall have permanent split capacitor (PSC) compressor motor with compressor start relay.

Units with three-phase power: Shall utilize three-phase compressors for balanced electrical compressor loads.

The condenser coil shall be constructed of copper tubes mechanically expanded to embossed aluminum plate fins. The unit shall be so designed as to allow access to the entering side of the condenser coil for cleaning without opening the sealed refrigeration circuit. The evaporator coil shall be constructed of copper tubing having embossed aluminum plate fins mechanically bonded thereto and shall be positioned above a galvanized steel drain pan.

Refrigerant shall be metered by a thermostatic expansion valve in lieu of capillary tubing to achieve evaporator performance and to protect the compressor from flood-

back of liquid refrigerant. The refrigerant section shall be adequately insulated to prevent “sweating.”

The unit shall be furnished and wired with compressor thermal/current overload and high pressure cutout. Gauge ports shall be provided to allow reading of refrigerant pressures at the suction and discharge of the compressor. Compressor shall be equipped with internal pressure relief valve to protect against excessive pressure buildup.

### (Optional) Electric Coils

Heating elements shall be of the open wire type. Electric heat shall be controlled in [three] stages. A capillary type high limit thermostat shall be provided to disconnect the heating elements through backup contactors if an overheat condition is detected. A front panel interlock switch shall be furnished to de-energize the electric resistance heating element when center front panel is opened.

### (Optional) Hot Water Coil

Coil shall be aluminum plate fin and copper tube construction. Coil shall be suitable for 150 psi working pressure. Coil shall be provided with an accessible manual air vent at the high point of the coil and a threaded drain plug at the low point of the coil.

Contractor shall provide all necessary balancing valves, shutoff valves and union connections in both the supply and return piping connections to permit removal of the unit from the wall sleeve for servicing.

Option: Coil shall be controlled by a 3-way (optional 2-way) modulating control valve and shall be factory wired by the unit ventilator manufacturer. Valve shall be field installed and piped by the installing contractor.

— OR —

Option: Coil shall be controlled by a modulating face and bypass damper. Coil shall have a 3-way, 2-position, end-of-cycle valve to shut off water flow when heating is no longer required. Valve and coil return shall have union connections. Valve shall be factory wired by the unit ventilator manufacturer and shall be field installed and piped by the installing contractor.

### (Optional) Steam Coil

Coil shall be aluminum plate fin and copper tube construction. Coil shall be double tube (DT) steam distributing, freeze resistant type. Coil shall be pitched to insure complete condensate removal for freeze protection and elimination of “water hammer.”

Contractor shall provide all necessary shutoff valves and union connections in both the supply and return piping connections to permit removal of the unit from the wall sleeve for servicing.

A pressure equalizing device (vacuum breaker) shall be factory installed to prevent the retention of condensate in the coil. The installing contractor shall connect the device to the return line beyond the trap using the tubing provided. Steam trap shall be furnished and field installed by the installing contractor.

Option: Coil shall be controlled by a 2-way, modulating control valve and shall be factory wired by the unit ventilator manufacturer. Valve shall be field installed and piped by the installing contractor.

— OR —

Option: Coil shall be controlled by a modulating face and bypass damper. Coil shall have a 2-way, 2-position, end-of-cycle valve to shut off steam when heating is no longer required. Valve and coil supply shall have union connections. Valve shall be factory wired by the unit ventilator manufacturer. Valve shall be field installed and piped by the installing contractor.

## Filter

Filter shall be one-piece design located to provide filtration of the outdoor air/return airflow. Separate filters for outdoor air and return air are not acceptable. Throwaway filter shall be factory furnished initially installed in the unit.

Option: Furnish \_\_\_\_\_ extra set(s) of throwaway filters.

Option: Furnish one set of wire mesh permanent filters as final filter.

Option: Furnish one set of renewable (metal frame with glass fiber media) filters as final filter.

Option: Furnish \_\_\_\_\_ roll(s) of renewable filter media.

## Acoustical Features

The compressor shall be mounted on compressor isolators for external vibration isolation. Compressor enclosure panels shall be 16-gauge minimum. Complete interior of compressor compartment shall be lined with a multi-functional material that serves as a sound barrier, an absorber of sound and also must act as a decoupler to the compressor enclosure. This multi-functional material shall have a mylar coating on the face to act as a sound reflector and to increase the strength of the material. Damping material shall be textured foam type.

The exterior of the compressor compartment shall be coated with a high density damping material to eliminate impact noise and vibration. The right-hand front panel and the hinged top access door shall be coated with a high density material to minimize noise and vibration.

## Temperature Controls

Each unit ventilator shall be furnished with a factory installed and wired, microprocessor based DDC Unit Ventilator Controller (UVC), by the manufacturer of the unit ventilator, which is pre-programmed, factory pretested prior to shipment and capable of complete, standalone unit control, or incorporation into a building-wide network using on-board BACnet MS/TP or an optional LONWORKS plug-in communication module.

The UVC shall support up to 16 analog inputs, 8 binary inputs, 4 analog outputs, 2 PWM outputs, and 14 binary outputs.

Units that are capable of providing up to 100% outside air shall provide a microprocessor-based Direct Digital Control (DDC) that can monitor conditions and automatically adjust unit operations to maintain these requirements. This DDC control shall have the following tenant adjustments: (1) room temperature setpoint, (2) minimum percent outdoor air setting, and (3) unoccupied setpoint (offset).

## Network System

1. The unit control system shall perform all unit control functions, unit diagnostics and safeties. The unit shall operate in the standalone or network capable mode of operation. Standalone units to have on-board BACnet MS/TP communication built in. Field furnished and installed controls shall not be allowed. When network capable, network communication module shall be factory installed, tested and able to communicate via plug-in communication module that connect directly to the UVC using:
  - a. BACnet Client-Server/Token Passing (MS/TP) allowing the UVC to inter-operate with systems that use the BACnet (MS/TP) protocol with a conformance level of 3 meeting the requirements of ANSI/ASHRAE 135- 2008 standard for BACnet systems.
  - b. LONMARK space comfort control that supports the LONMARK SCC profile number 8500-10 allowing LONWORKS network communication capability to the UVC.

2. Unit controls shall allow for monitoring and adjustment via Daikin ServiceTools using a PC with Windows® 98 (Second Edition) through Windows 10 operating systems. When using this PC and software, the unit shall be capable of reacting to commands for changes in control sequence and set points.

## Room Temperature Sensor

### **Unit-Mounted**

Units shall have a temperature sensor located in a sampling chamber to allow a constant circulation of room air to flow across the sensing device. The sampling chamber shall be designed in such a manner that will ensure rapid and accurate sensing of room air.

### **Wall-Mounted Sensor**

Units shall have a temperature sensor with status LED furnished for mounting to the wall. [Option: In addition, a tenant override switch shall be furnished as part of the wall mounted sensor.]

### **Wall-mounted Sensor with Tenant Override and Setpoint Adjustment**

A sensor with integral tenant override and status LED shall be furnished with the unit ventilators. This sensor shall also contain a manually adjustable temperature setting allowing the controller setpoint to be increased or decreased by 5°F (2.8°C).

## Night Controls

Night set-back/set-up control shall be provided by (SELECT one):

- a. An internal daily schedule provides two occupied times and two unoccupied times for each of the seven days of the week and one set for holidays. The operator may select the month and date when the holiday schedule is used by selecting a start date and the number of days to run for up to sixteen periods.
- b. The network DDC control system.

## Wall Sleeve

The galvanized steel, one-piece wall sleeve shall be set in a wall opening and butted up directly against the intake louver. Where it is not possible to butt the wall sleeve against the wall intake louver, the contractor shall fabricate and install horizontal air splitters between the louver and wall sleeve to provide an airtight separation between condenser discharge and return air. The wall sleeve is to be permanently fastened in place and shall be suitably sealed, caulked or grouted by the contractor around the entire perimeter to prevent air leakage.

The wall sleeve shall be fitted with an electrical junction box containing a main “on-off” switch. All field wiring connections shall be made in this wall sleeve junction box.

(It shall be the installing contractor’s responsibility to make the final load side power wiring connections between the wall sleeve junction box and the unit terminal block (including the wiring going to the electric heating elements. The wall sleeve shall be cartoned separately and shipped to the job site preceding the unit ventilator. Junction box shall ship separately for field installation.)

## Wall Intake Louver

The louver shall be supplied by the unit manufacturer and shall be of heavy-gauge (unpainted, painted, or clear anodized) aluminum construction. The louver shall be of the vertical blade type and shall be divided in half horizontally across the louver to prevent condenser air recirculation. A diamond pattern mesh bird screen shall be provided on the backside of the wall intake louver. All louvers shall be 28" (711mm) high by 2-1/2" (57mm) thick and suitable for both masonry and panel wall construction. The frame of the louver shall have weep holes along the bottom. Lintels shall be provided by the contractor above the louver opening.

Optional: Heavy-duty lattice grille horizontal and vertical lines shall “line up” with the louver blades to present an aesthetic appearance. Grille shall be fabricated from mill finish aluminum.

## Drain Pan

All units shall have a drain pan constructed of galvanized steel.

[Option: Drain pan shall be constructed of stainless steel.]

## Agency Listing

Unit ventilators shall be listed by Underwriters Laboratories Inc. (U.L.) for the United States and Canada. Motors shall conform to the latest applicable requirements of NEMA, IEEE, ANSI, and NEC standards.



### ***Daikin Applied Training and Development***

Now that you have made an investment in modern, efficient Daikin equipment, its care should be a high priority. For training information on all Daikin HVAC products, please visit us at [www.DaikinApplied.com](http://www.DaikinApplied.com) and click on Training, or call 540-248-9646 and ask for the Training Department.

### ***Warranty***

All Daikin equipment is sold pursuant to its standard terms and conditions of sale, including Limited Product Warranty. Consult your local Daikin Applied representative for warranty details. Refer to Form 933-430285Y. To find your local Daikin Applied representative, go to [www.DaikinApplied.com](http://www.DaikinApplied.com).

### ***Aftermarket Services***

To find your local parts office, visit [www.DaikinApplied.com](http://www.DaikinApplied.com) or call 800-37PARTS (800-377-2787). To find your local service office, visit [www.DaikinApplied.com](http://www.DaikinApplied.com) or call 800-432-1342.

This document contains the most current product information as of this printing. For the most up-to-date product information, please go to [www.DaikinApplied.com](http://www.DaikinApplied.com).

Products manufactured in an ISO Certified Facility.