



Catalog 1118-3

SmartSource® Compact Horizontal Water Source Heat Pump

Model GCH- Single Stage

Model GDH- Two Stage

Sizes 007 – 070 (1/2 thru 6 tons)



Model Nomenclature	2	Water System Quality	22
AHRI Performance Data	4	Condensate Drain	23
Compact model GCH with PSC motor	4	Operating Limits	23
Compact model GCH with EC motor	4	Performance Data	24
Features and Options	5	Fan Performance for Standard PSC Motor – 208V Operation	24
SmartSource® Compact Horizontal Water Source Heat Pump - GCH	5	Fan Performance For Optional Constant Torque EC Motor (Sizes 007–012)	25
Contractors/Facility Managers:	5	Fan Performance For Optional Constant Torque EC Motor (Sizes 015–070)	26
Specifying Engineers:	5	Fan Performance For Optional Constant CFM EC Motor (Sizes 015–070)	27
Building Owners:	5	GCH Waterside Economizer Cooling Capacity	29
Hot Gas Reheat Coil	6	Electrical Data	30
Waterside Economizer	6	Unit With Standard PSC Motor	30
Designed-in Sound Reduction	7	Unit With Optional EC Constant Torque Motor	31
Sound Options	7	Unit With Optional EC Constant CFM Motor	32
Fan Motors	8	Physical Data	33
MicroTech® Unit Control	11	GCH Units	33
Controls	11	Dimensional Data	34
MicroTech® SmartSource Controller with LONWORKS® Communication Module	12	GCH Unit, Left and Right Hand, End and Straight Discharge – 007-036	34
MicroTech SmartSource Controller with BACnet® Communication Module	12	GCH Unit, Left and Right Hand, End and Straight Discharge – 042-070	35
Accessories	13	GCH Unit, Left and Right Hand, End and Straight Discharge – 007-036	36
Hoses, Hose Kits and Shutoff Ball Valves for SmartSource Water Source Heat Pumps	13	GCH Unit, Left and Right Hand, End and Straight Discharge – 042-070	37
Supply and Return Hose Kits	13	Optional Filter Racks Dimensions	38
Shutoff Ball Valves with Memory Stop	13	Optional Disconnect Switch Location Dimensions	39
Control Accessories	14	Model GCH Unit With Waterside Economizer Dimensions	40
Wall-Mounted Programmable Electronic Thermostats for MicroTech III Unit Controller – Standalone Operation	14	Model GCH Engineering Guide Specifications	41
Room Temperature Sensors for MicroTech Unit Controller – Building Automated System (BAS) Operation	15		
Control Accessories	16		
Applications	19		
Typical Horizontal Installation	19		
Ductwork and Attenuation	20		
Piping	21		

Model Nomenclature

1	2-3	4	5-7	8	9	10-11	12	13	14	15	16-17	18	19	20	21	22	23-24	25	26	27
W	GC	H	007	E	1	LS	S	M	T	D	WE	2	1	P			75	E	D	3

Category	Code Option	Code Designation	Description
Product Category	1	W	= Water Source Heat Pump
Model Type	2-3	GC	= Compact Single Stage
		GD	= Compact Two Stage
Configuration	4	H	= Horizontal
Nominal Capacity	5-7	007	= 7,000 Btuh Nominal Cooling
		009	= 9,000 Btuh Nominal Cooling
		012	= 12,000 Btuh Nominal Cooling
		015	= 15,000 Btuh Nominal Cooling
		019	= 19,000 Btuh Nominal Cooling
		024	= 24,000 Btuh Nominal Cooling
		030	= 30,000 Btuh Nominal Cooling
		042	= 42,000 Btuh Nominal Cooling
		048	= 48,000 Btuh Nominal Cooling
		060	= 60,000 Btuh Nominal Cooling
		070	= 70,000 Btuh Nominal Cooling

Nomenclature (Continued)

1	2-3	4	5-7	8	9	10-11	12	13	14	15	16-17	18	19	20	21	22	23-24	25	26	27
W	GC	H	007	E	1	LS	S	M	T	D	WE	2	1	P			75	E	D	3

Category	Code Option	Code Designation	Description
Voltage	8	A	= 115/60/1 (007-015)
		E	= 208-230/60/1 (007-070)
		F	= 208-230/60/3 (024-070)
		J	= 265/60/1 (007-036)
		K	= 460/60/3 (024-070)
		L	= 575/60/3 (048-070)
Design Series (Vintage)	9	1	= Revision / Design Series 1
Return Air / Discharge Air	10-11	LS	= Left Hand Return / Straight Discharge
		LE	= Left Hand Return / End Discharge
		RS	= Right Hand Return / Straight Discharge
		RE	= Right Hand Return / End Discharge
Water Coil Type	12	C	= Copper Inner Tube
		S	= Cupro-Nickel Inner Tube
		G	= Geothermal - Copper Inner Tube
		J	= Geothermal - Cupro-Nickel
Unit Control	13	M	= MicroTech III SmartSource Unit Controller
		L	= MicroTech III Unit Controller + LON
		B	= MicroTech III Unit Controller + BACnet
Fan Motor	14	P	= PSC
		C	= ECM Constant CFM
		T	= ECM Constant Torque
Insulation (Compressor Side / Airside)	15	B	= Standard (1/2" Fiberglass, Entire Unit)
		I	= IAQ (Closed Cell Foam, Entire Unit)
		D	= Dual Layer Fiberglass (Entire Unit) (sizes 007-019)
		F	= Sound Blanket + Standard (1/2" Fiberglass)(sizes 024-070)
		G	= Sound Blanket + IAQ (Closed Cell Foam) (sizes 024-070)
		H	= Sound Blanket + Sound Package (1" Fiberglass / Dual Layer Fiberglass) (sizes 024-070)
Options	16-17	WE	= Waterside Economizer
		HG	= Hot Gas Reheat
Filter & Racks	18	1	= Standard 1" Rail - 1" Throwaway Filter
		2	= 2" Rack - 2" Filter (MERV 8)
		4	= 4" Rack - 4" Filter (MERV 13)
Piping Package	19	0	= None
		1	= Isolation Valve (Normally Open) (Available only on sizes 015-070)
		2	= Isolation Valve (Normally Closed) (Available only on sizes 015-070)
Electric Heat	20	0	= None
		P	= Control for Electric Heat Single 24V Signal (Field Installed Duct Heater by Others)
Additional Options	21	0	= None
		F	= Freeze Fault Protection
		A	= Alarm Relay
		B	= Alarm Relay and Freeze Fault Protection
		C	= Water Pressure Differential Switch
		D	= Freeze Fault Protection and Pressure Differential Switch
		E	= Alarm Relay and Pressure Differential Switch
G	= Alarm Relay, Freeze Fault Protection and Pressure Differential Switch		
Standard or Special	22	S	= Standard
		X	= Special
Transformer	23-24	50	= 50VA Transformer
		75	= 75VA Transformer
Corrosion Protection	25	0	= None with Stainless Steel Drain Pan
		A	= None with Plastic Drain Pan
		E	= Corrosion Protection with Stainless Steel Drain Pan (Coated Air Coil Includes WSE and HGRH if applicable)
		F	= Corrosion Protection with Plastic Drain Pan (Coated Air Coil Includes WSE and HGRH if applicable)
Disconnect Switch	26	0	= None
		D	= Disconnect Switch

Compact model GCH with PSC motor

Note: All data below rated in accordance with AHRI/ASHRAE/ISO Standard 13256-1. All ratings based on 208V operation.

Unit Size	Motor Type	CFM	GPM	Water Loop (Boiler Tower)				Ground Loop (Geothermal)			
				Cooling		Heating		Cooling		Heating	
				Btu/hr	EER	Btu/hr	COP	Btu/hr	EER	Btu/hr	COP
007	PSC	250	1.75	6,200	14.5	8,200	5.3	6,700	17.4	4,900	3.3
009		300	2.25	9,400	13.4	11,900	4.7	10,000	16.0	7,600	3.4
012		400	3	11,600	12.9	15,000	4.3	12,300	15.0	9,600	3.2
015		500	3.5	14,400	15.3	18,000	5.4	15,100	18.1	11,100	3.8
019		600	4.5	17,100	15.3	21,600	5.3	18,000	17.9	13,600	3.8
024		800	6.0	23,500	14.5	28,200	4.7	24,400	16.5	18,000	3.3
030		1,000	7.5	28,000	13.5	34,300	4.4	29,200	15.5	22,600	3.2
036		1,200	9	36,000	14.4	42,400	4.6	37,300	16.5	27,100	3.2
042		1,400	10.5	40,800	14.8	44,600	4.4	42,300	16.6	30,200	3.2
048		1,600	12.0	47,400	14.0	58,900	4.6	48,800	16.1	38,600	3.5
060		2,000	15.0	60,000	13.1	76,900	4.3	62,200	14.9	49,300	3.2
070		2,300	18.0	68,100	14.0	81,000	4.5	71,000	15.9	53,300	3.3

Compact model GCH with EC motor

Unit Size	Motor Type	CFM	GPM	Water Loop (Boiler Tower)				Ground Loop (Geothermal)			
				Cooling		Heating		Cooling		Heating	
				Btu/hr	EER	Btu/hr	COP	Btu/hr	EER	Btu/hr	COP
007	ECM	250	1.75	6,300	15.2	8,100	5.4	6,800	18.3	4,800	3.5
009		300	2.25	9,300	13.7	11,800	4.8	9,900	16.2	7,500	3.5
012		400	3	11,800	13.3	15,000	4.4	12,500	15.4	9,500	3.2
015		500	3.5	14,500	16.8	17,600	5.7	15,300	19.9	10,700	3.9
019		600	4.5	17,400	16.3	21,200	5.5	18,300	19.0	13,200	3.9
024		800	6.0	23,700	15.4	27,700	4.8	24,600	17.6	17,500	3.3
030		1,000	7.5	28,300	14.0	33,600	4.5	29,400	16.0	21,400	3.3
036		1,200	9	36,200	14.9	41,900	4.8	37,500	17.2	26,600	3.3
042		1,400	10.5	41,100	15.2	44,400	4.4	42,600	17.0	30,000	3.2
048		1,600	12.0	47,600	14.9	58,600	4.9	49,100	17.1	38,400	3.7
060		2,000	15.0	60,500	13.8	77,400	4.5	61,500	15.5	49,800	3.4
070		2,300	18.0	68,500	14.7	80,000	4.6	71,400	16.9	52,300	3.4

Compact model GDH (2-stage)

Note: 2-stage data presented at full load operation

Unit Size	CFM	GPM	Water Loop (Boiler Tower)				Ground Loop (Geothermal)			
			Cooling		Heating		Cooling		Heating	
			Btu/hr	EER	Btu/hr	COP	Btu/hr	EER	Btu/hr	COP
024	800	6.0	24,000	15.7	28,000	4.7	25,400	18.3	17,500	3.4
030	1,000	7.5	28,000	13.8	34,000	4.3	29,300	15.7	22,000	3.2
036	1,200	9	36,400	15.4	41,700	4.7	37,900	17.6	26,200	3.3
042	1,400	10.5	41,600	14.6	45,800	4.4	43,600	16.9	30,800	3.3
048	1,600	12.0	47,000	14.7	56,600	4.9	48,900	16.8	36,800	3.6
060	2,000	15	54,300	13.9	71,200	4.7	55,600	15.5	46,700	3.6
070	2,250	18.0	68,500	15.0	80,500	4.6	71,400	17.0	51,700	3.4

Legend: Btuh = British Thermal Units per Hour
EER = Energy Efficiency Ratio

CFM = Airflow Rate, Cubic Feet per Minute
GPM = Gallons per Minute

COP = Coefficient of Performance
* = Constant torque EC motor only

Water Loop:

1. Cooling capacity is based on 80.6°F db, 66.2°F wb (27/19°C) EAT and 86°F (30°C) EWT.
2. Heating capacity is based on 68°F db, 59.0°F wb (20/15°C) EAT and 68°F (20°C) EWT.

Ground Loop:

1. Cooling capacity is based on 80.6°F db, 66.2°F wb (27/19°C) EAT and 77°F (25°C) EWT.
2. Heating capacity is based on 68°F db, 59.0°F wb (20/15°C) EAT and 32°F (0°C) EWT.

SmartSource® Compact Horizontal Water Source Heat Pump - GCH

We at Daikin have lead the way for over 40 years in horizontal water source heat pump design, with a focus on small-scale, serviceable units that provide commercial building contractors and facility managers with a low-cost alternative to more expensive and larger water source heat pumps. Readily available in-stock, Compact units are ideal for new, existing, or replacement jobs where space is premium and budgets are constrained. They can be configured for boiler tower or geothermal applications often found in schools, offices, lodging, condominiums, and retail facilities.

Although small in size, Compact units deliver big in performance capabilities. Specifying engineers will appreciate all the high-performing features and options built into the Compact design; EC motors with adjustable air flow settings, dehumidification, and waterside economizer (typically found only in larger water source heat pumps), now fully selectable and available in this smaller packaged unit, and at a lower cost.

With so many performance design features and options available with the Compact unit, building owners can expect a quiet and more comfortable environment for occupants, in addition to a low first-installed cost, efficient, cost-saving operation, and lower energy bills each year.

Compact Footprint, Large Unit Features at Low Cost

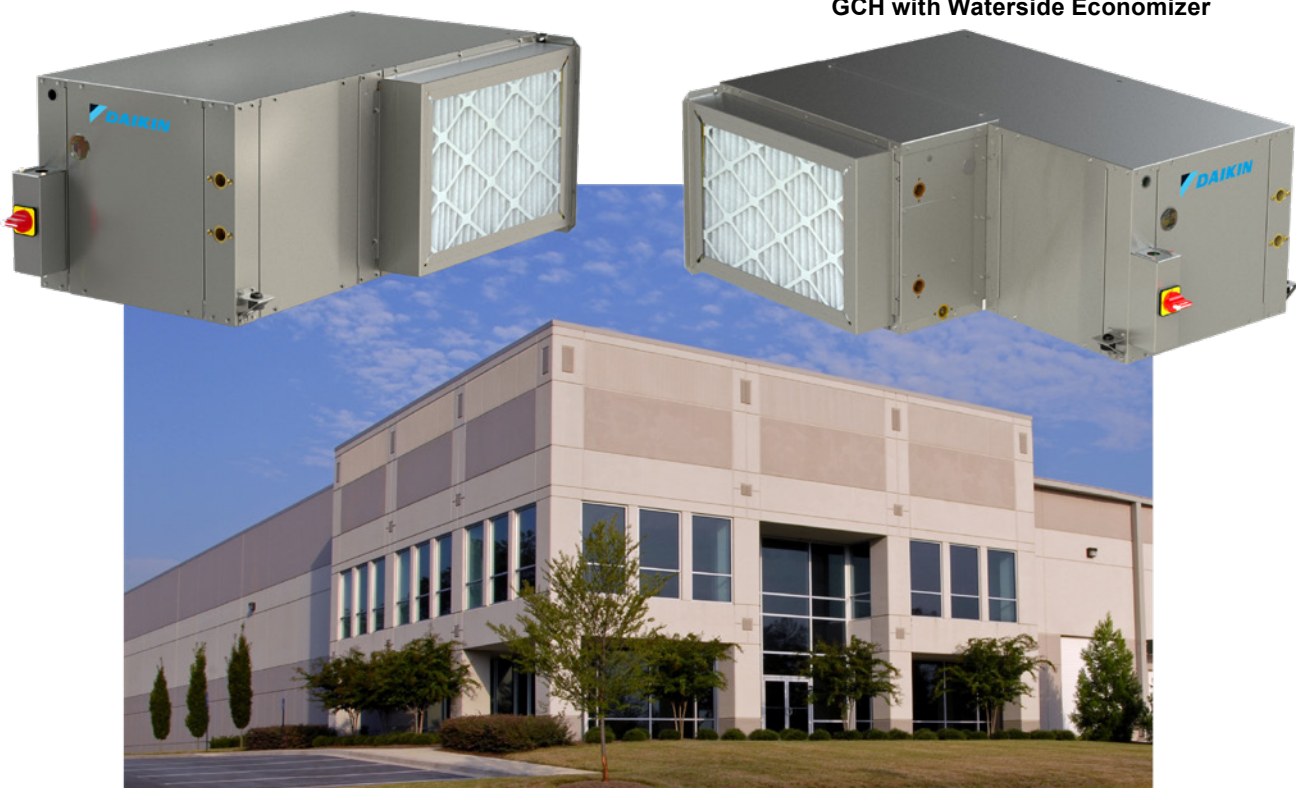

Contractors/Facility Managers:

- SmartSource Compact fits where there's limited, valuable space
- Designed for smooth quick installation

Specifying Engineers:

- Compact delivers high performance and quiet operation
- Boasts features and options typical of larger units, at a low price
- Has one of the smallest footprint in the industry

Building Owners:

- Compact design
- Quiet operation with improved comfort
- Low first-installed cost
- Reliable, efficient cost-saving operation.

Hot Gas Reheat Coil

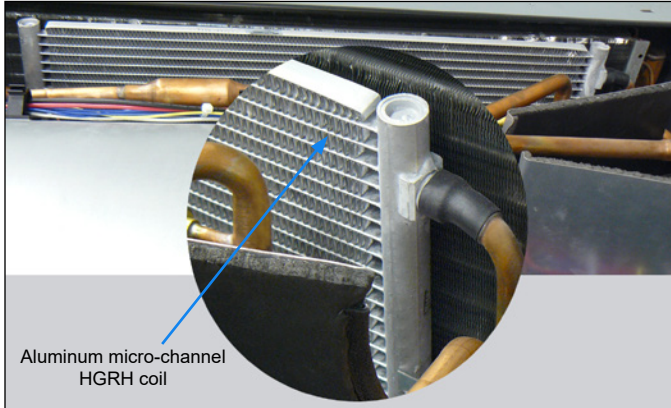

For improved indoor climate control, Daikin Applied offers accurate and cost effective dehumidification control using a hot gas reheat option known as smart dehumidification. Hot gas reheat with smart dehumidification is an excellent solution for applications where maintaining low humidity in a space is crucial.

With smart dehumidification, once the space temperature is satisfied, the humidistat signal diverts the high temperature refrigerant gas to the reheat coil located downstream of the cooling coil. The conditioned and reheated air prevents over cooling of the space and maximizes moisture removal for improved indoor comfort. With the optional ECM fan system, the air flow is adjusted for optimal moisture removal, and helps keep sound levels at a minimum. It is especially effective during low load conditions when proper control is critical.

Waterside Economizer

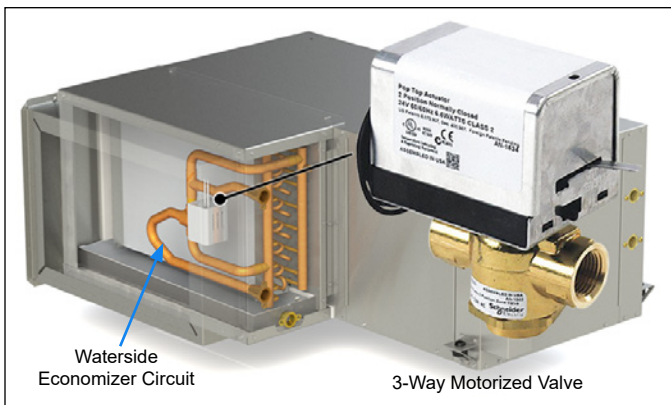

The waterside economizer option helps to reduce energy consumption by using cold loop water temperature to condition a space without energizing mechanical cooling. Even in the coldest weather a space can experience a build-up of ambient heat from people, equipment, lighting and the sun. Buildings benefit from the waterside economizer when loop temperatures are cool enough to provide air conditioning. The waterside economizer includes a hydronic cooling coil, 3-way motorized valve and an entering water sensor located upstream of the unit's evaporator coil.

When entering water temperatures are between 40° to 70°F, a call for 1st-stage cooling will divert the cold water to the economizer coil. A call for 2nd-stage cooling will allow simultaneous compressor operation whenever the loop temperature is below the changeover temperature.

Cabinet Configurations

The SmartSource compact cabinet is fabricated from heavy gauge G-60 galvanized sheet metal.

Four cabinet configurations are available in either a left-hand or right-hand return air arrangement to provide the optimum return air location and service access.

Figure 1: Four horizontal unit configurations

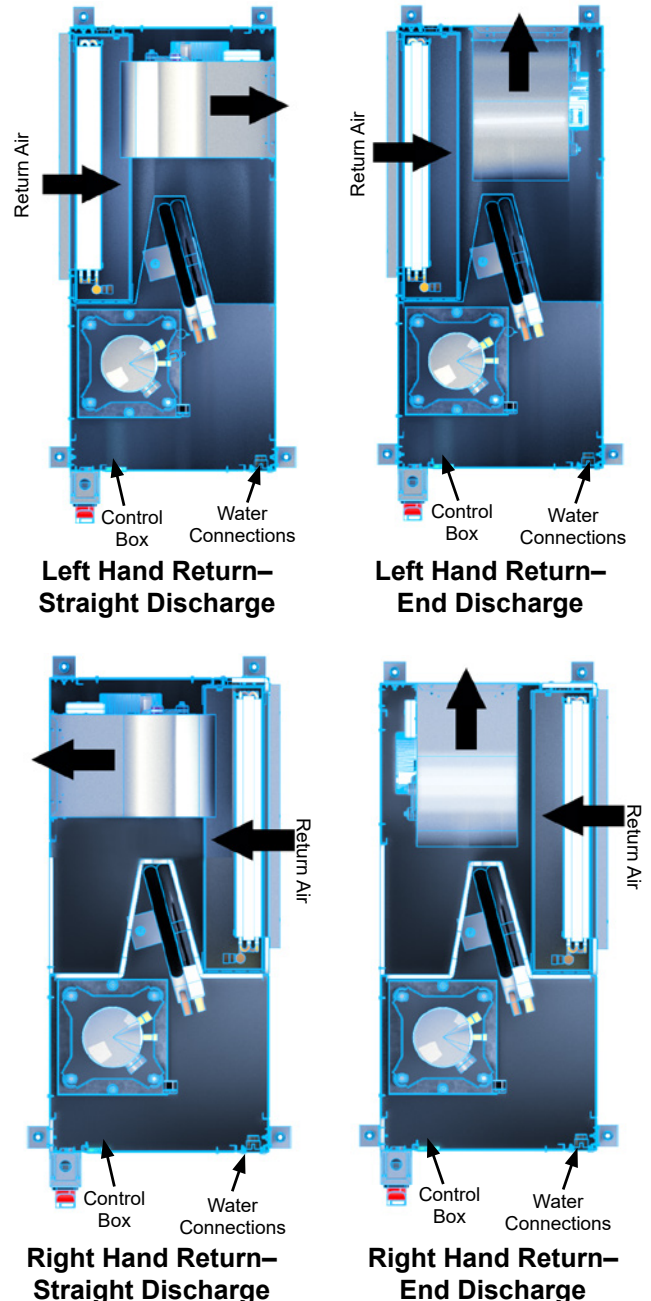

Note: Unit left or right hand is determined by facing the water connections (front) side of unit

Designed-in Sound Reduction

Provided as standard, the unit has a unique dual-level vibration isolation system. A heavy-gauge mounting plate is isolated from the cabinet base with a 1/2" thick dense foam pad to minimize vibration transfer. The compressor is then isolated from the mounting plate with isolation grommets. The compressor is located in a well-insulated compartment separated from the air stream to minimize sound transmission.

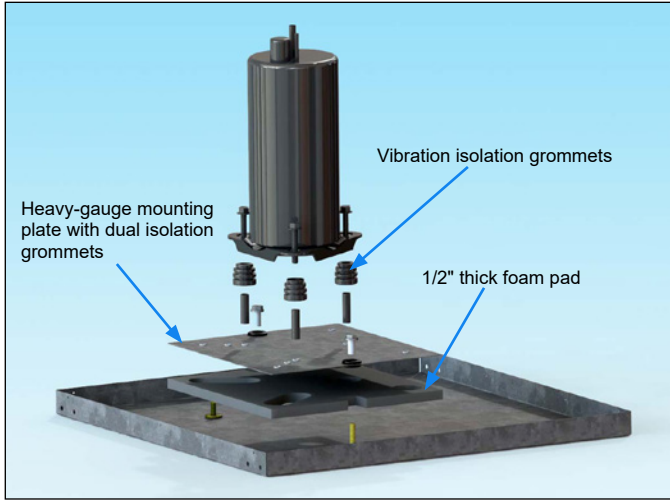

Cabinet Insulation

Dual density 1/2" fiberglass insulation is standard on all Compact units for improved thermal and acoustic performance. The insulation meets NFPA 90A/90B requirements, air erosion and mold growth limits of UL-181, fungal resistance test per ASTM G21 or ASTM C 1338, and meets zero level bacteria growth per ASTM G22. All insulation has a flame spread of less than 25 and a smoke developed classification of less than 50 per ASTM E-84 and UL 723.

IAQ Insulation (Option)

Optional insulation is available with closed-cell non fibrous insulation for Indoor Air Quality (IAQ).

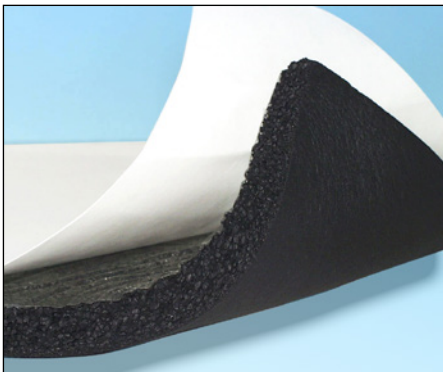

Closed cell foam insulation

Sound Options

Sound Package

Available as a factory installed option, unit sizes 024-070 utilize sound attenuating compressor blankets combined with a dual layer of fiberglass insulation that is strategically placed in the air handling compartment. Unit sizes 007-019 have a dual layer of fiberglass insulation that is strategically placed in both the air handling and compressor compartments.

Sound Options

Sound attenuating compressor blankets for unit sizes 024-070 are available. They may be ordered on non sound package units as well.

Discharge & Return Fold Out Duct Collars

Optional 2-inch and 4-inch deep return air filter racks and the discharge air opening have duct collars that are perforated and easily bend out for connecting ductwork. This design helps to prevent damage during shipping and handling.



Stainless Steel Drain Pan (Option)

The condensate drain pan is constructed of corrosion-resistant stainless steel. It is tilted from two directions toward the drain end using tapered foam strips on its underside that also help minimize sound transmission between the pan and partition plate. The entire bottom of the drain pan is covered with 1/4" insulated foam that helps reduce sweating. The drain pan includes an electronic condensate overflow protection sensor, more reliable than a mechanical float switch used with many competitor pans.



EC Constant CFM Fan Motor (Option)

For unit sizes 015 – 070, the high efficiency EC constant airflow motor option provides constant airflow and economical performance over a wide static pressure range. This motor is an ideal option for high filtration applications, utilizing an optional MERV-13 air filter. One of the many benefits of the EC motor is a soft start/stop feature for quiet operation. The 4-speed fan selector switch allows for quick fan speed adjustment to optimize unit performance.

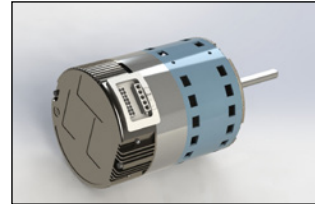

Fan Motors

Permanent Split Capacitor Motor (PSC)



All units are equipped standard with a 3-speed PSC motor. The motors are permanently lubricated and include thermal overload protection for years of maintenance free service. The motor is factory wired to maximize performance and efficiency. The motor is isolated from the fan housing using rubber isolators to minimize vibration transmission. All blower/motor assemblies have a removable orifice ring on the housing to accommodate motor and blower removal without disconnecting the unit from the ductwork.

Non-Fused Disconnect Switch (Option)

Compact units are available with an optional non-fused disconnect switch, located on the unit front corner post. The disconnect switch is used to break power to the unit for ease of field service and is provided with a lockout/tag out feature.



EC Constant Torque Fan Motor (Option)



Constant Torque EC Motor Sizes 007-012



Constant Torque EC Motor Sizes 015-070

The optional constant torque EC blower motor offers increased efficiencies. This motor is similar in function to a PSC, but will deliver airflow at higher external static pressures. These motors are available for all sizes 007 to 070. Size 007 through 012 include a field adjustable 4-position fan speed selector switch. Unit sizes 015 through 070 offer five selectable motor speed taps. This EC motor option is an excellent choice for retrofit projects. These motors do not require a neutral wire for 460/3 electrical.

High Efficiency Rotary or Scroll Compressor

Compressors are high efficiency rotary (sizes 007-019) and scroll (sizes 024-070) designed for heat pump duty. Mounted on a dual isolation system for reduced sound and vibration.



Two-Stage Compressor (Option) - Sizes 024-070

The two-stage unloading scroll compressor provides excellent part load performance for improved humidity control and increased efficiency.

Freeze Fault Protection (Option)

This factory installed option adds a leaving water temperature (LWT) sensor to disable compressor operation to protect against coil freeze-up.

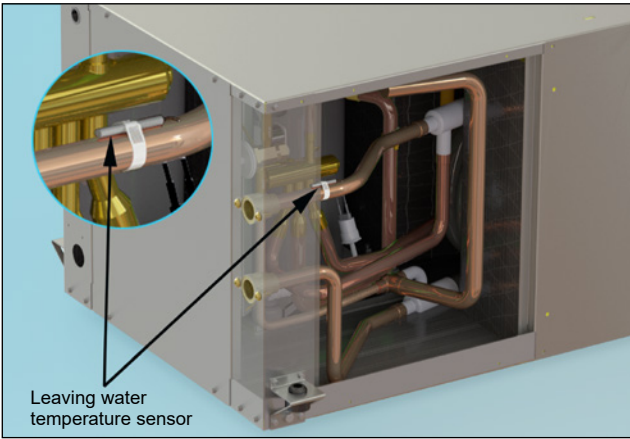

Water Connections

The water and condensate connections are FPT fittings, securely mounted flush to the corner post to allow for connection to a flexible hose without the use of a back-up wrench for easy installation.



Service Valve Connections

Two service valves are located inside the lower-front access panel – one on the low side and one on the high side of the refrigeration circuit. Easily accessible for routine service.



Water Pressure Differential Switch

The pressure differential switch monitors water pressure drop across the heat exchanger and will disable compressor operation if flow is not detected. Selectable as a factory installed option internal to the cabinet.

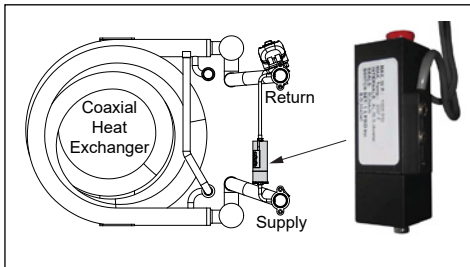

Air-to-Refrigerant Coil

The air-to-refrigerant heat exchanger has copper tubes and aluminum fins. The fins are lanced and mechanically bonded to the tubes using finned edges on the inside which expand during assembly to enhance heat transfer capabilities. The coil is designed for optimal performance in both heating and cooling while maintaining the benefit of a compact size. The coils can be coated with an optional inorganic, silicon-based nano-ceramic coating. This coating has a 3,000 hour salt spray rating per ASTM B-117.

2-Way Motorized Water Valves (Option)

2-way valves are used for variable pumping applications when more than one unit is installed on a common loop. These valves are also used to conserve water when used for ground water applications.

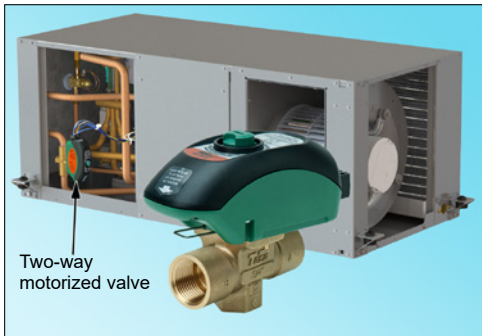

Coax Coil

The water-to-refrigerant heat exchanger is a coaxial coil with a convoluted copper inner tube and a steel outer tube. The convoluted tube has increased heat transfer surface area per unit length for enhanced performance. The coil is rated for 500 psig on the water side and 600 psig on the refrigerant side. An optional a cupro-nickel inner tube is available for applications with lower water quality.



Table 1: Available motorized valves

Type	Sizes	Connection
2-Way Motorized	1/2", 3/4", 1"	Sweat
	1/2", 3/4", 1"	NPT

Filters & Filter Racks

Units come standard with a 1" thick factory-installed disposable filter. The two-sided, (top and bottom) filter rails allow for the filter to be easily removed from either the left or right side.

An optional 2" deep (4-sided, low leak) filter rack is available as a factory-installed selectable option and accepts a MERV 8 filter. An optional 4" deep (4-sided, low leak) filter rack accepts a MERV 13 filter. These optional (low leak) racks include gaskets between the filter rack and cabinet that maintain the leakage rate below 4 CFM per square foot of filter area at .5" ESP. The 4-sided filter rack has a removable access door with thumb screws for easy filter access and change-out without the use of a tool.

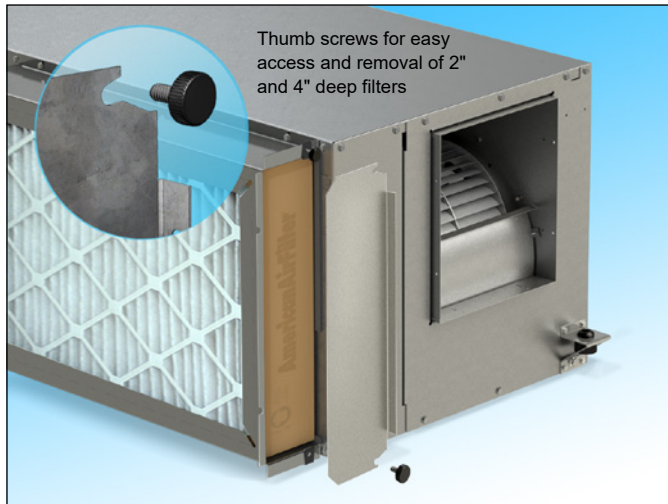

Hanger Brackets

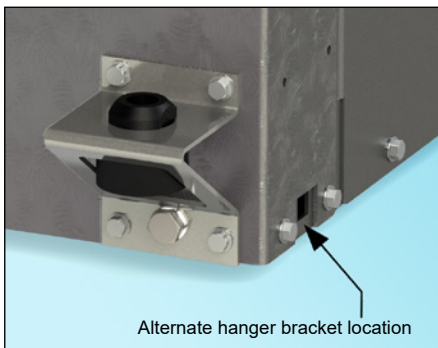

Robust, interchangeable hanger brackets ship mounted on the unit.

LED Sight Glass

The LED status sight glass allows an instant visual of unit operation for quick troubleshooting and advanced diagnosis without removing the access panel.

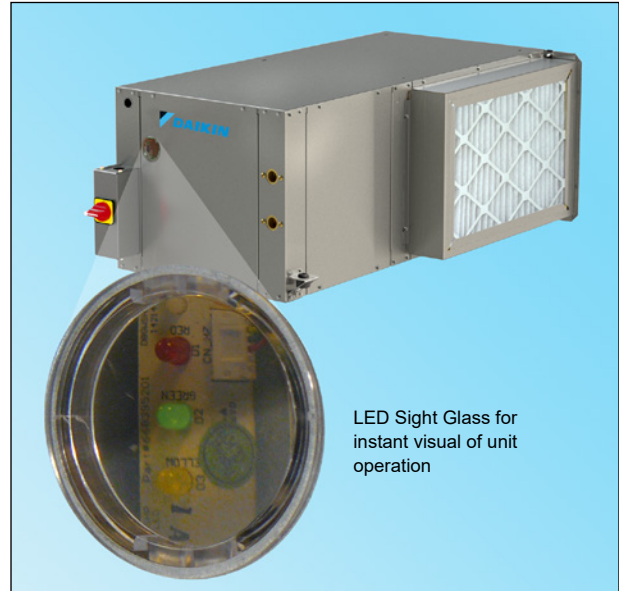

Fan Speed Selector Switch

Available on units with EC constant torque motor (sizes 007-012) and EC constant CFM motor (sizes 015-070).

A 4-position fan speed selector switch located in the control box allows CFM settings to be field adjustable. Fan speed control optimizes unit fan speed based on thermostat/room sensor inputs. The fan speed switch allows for manually setting an optimal fan speed specific to the application requirements. Each position on the fan speed switch represents settings 1-4. See [Table 2](#) below and [Table 13 on page 27](#) for a complete list of fan speed selector switch settings.



Table 2: Single or two-stage units with constant CFM type EC motor - Fan speed selector switch settings example

Unit Size	MicroTech Unit Controller						I/O Expansion Module		
	Setting	Maximum ESP (in. wg.) ²	Heat/Cool Stage 1	Heat/Cool Stage 2	Dehumidification	Electric Heat	Setting	Fan Only	Waterside Economizer
024	4 (High)	0.7	800	900	750	900	A	800	800
	3 (Standard)		700	800	650	900	B	700	700
	2 (Medium)		560	700	560	900	C	560	560
	1 (Low)		560	560	560	900	D	450	560

MicroTech® Unit Control



MicroTech Controller

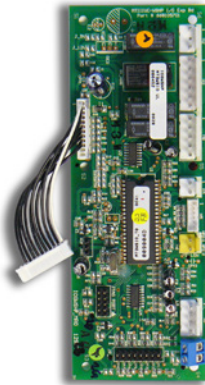

Expansion Module

The MicroTech controller is a microprocessor-based controller and is provided on every GCH unit. The controller monitors the safety devices to protect the unit from unsafe operating conditions, controls the reversing valve, compressor and fan operation for efficient unit operation. This controller also protects against freezing of the water to refrigerant and air to refrigerant heat exchanger as well as condensate overflow.

Safety Controls included as standard:

- High pressure switch located in the refrigerant discharge line.
- Low pressure switch located in the refrigerant suction line for loss of refrigerant charge protection.
- Low suction temperature sensor located in the compressor suction line to protect against coil freeze-up.
- Condensate overflow protection sensor is factory mounted in the drain pan of the unit.

The controller is accessible within the electrical control box through the front access panel.

For additional information on the MicroTech controller, see OM 1149.

Each option features direct quick-connect wiring to all unit-controlled components for “clean” wiring inside the control box. Each control circuit board receives power from a 50 VA or optional 75 VA transformer. The main board can be wired for 24-volt AC output to the wall thermostat by using terminals R & C.

Built-in Diagnostics

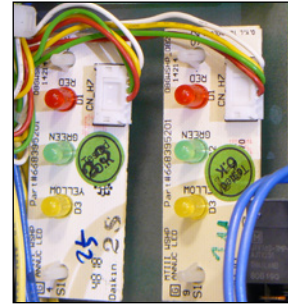

Status LED annunciator lights are located on the interior of the unit, located below the fan speed switch and are easily viewable through the sight glass to quickly check the operating status of the unit. The I/O Expansion Module has an independent LED annunciator to identify operational fault conditions.

By adding a communication module, LONWORKS or BACnet, network Building Automation System (BAS) integration is possible.

Three control choices are offered with the MicroTech SmartSource unit control system:

- MicroTech SmartSource unit controller (Standalone)
- MicroTech SmartSource unit controller with LONWORKS® communication module
- MicroTech SmartSource unit controller with BACnet® communication module

Controls Integration

For protocol information including, integration points list for LONWORKS and BACnet networks, Refer to ED 15103.

MicroTech® SmartSource Controller with LONWORKS® Communication Module



Each Daikin water source heat pump can be equipped with a LONWORKS communication module that is LONMARK 3.4 certified. The controller is microprocessor-based and is designed to communicate over a LONWORKS communications network. It can be factory or field-installed.

For installation details of the field-installed kit, "Micro-Tech Water Source Heat Pump LONWORKS Communication Module", refer to IM 927.

The unit controller is programmed and tested with all the logic required to monitor and control the unit. An optional wall sensor may be used with the communication module to provide limited local control of the Water Source Heat Pump. The unit controller monitors water and air temperatures and passes information to the communication module. The module communicates with the BAS, to provide network control of the Water Source Heat Pump.

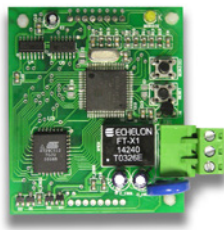

The MicroTech SmartSource unit controller with communication module includes a factory installed leaving water temperature sensor, field installed discharge air and return air temperature sensor. A Daikin wall-mounted temperature sensor may be used in place of the factory provided return air temperature sensor.

MicroTech SmartSource Controller with BACnet® Communication Module



Daikin water source heat pumps are available with a BACnet MS/TP communication module that is designed to communicate over a BACnet MS/TP communications network to a building automation system (BAS). It can be factory or field-installed.

For installation details of the field-installed kit, "Micro-Tech Water Source Heat Pump LONWORKS Communication Module", refer to IM 928.

The unit controller is programmed and tested with all the logic required to monitor and control the unit. An optional wall sensor may be used with the communication module to provide limited local control of the water source heat pump. The unit controller monitors water and air temperatures and passes information to the communication module. The module communicates with the BAS, to provide network control of the water source heat pump.

The module makes operational data and commands available on a communications network using BACnet objects and properties:

- The network cable is a shielded twisted-pair cable
- Network communications run up to 76.8 Kbps
- DIP switches on the controller enable the MS/TP MAC address to be set in the range 0-127
- Four green status LEDs on the communication module indicate communication activity on the MS/TP communication network and with the unit controller

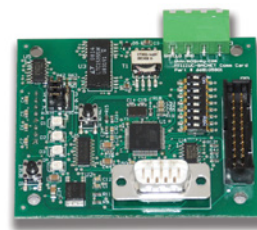

The MicroTech SmartSource unit controller with communication module includes a factory installed leaving water temperature sensor, field installed discharge air and return air temperature sensor. A Daikin wall-mounted temperature sensor may be used in place of the factory provided return air temperature sensor.

Hoses, Hose Kits and Shutoff Ball Valves for SmartSource Water Source Heat Pumps

Daikin offers a variety of flexible supply, return and condensate hoses and hose assemblies for connecting its water source heat pumps to a building's hard piping system. See catalog 1196 for the complete hose and hose kit offering.

Figure 2: Flexible, steel braided supply and return hoses



Supply and return hoses have a swivel fitting at one end to facilitate removal of the unit for replacement or service. Standard supply and return fire-rated hoses have either a thermoplastic rubber or synthetic polymer core with a braided covering of stainless steel. Fittings are either plated steel or brass.

Table 3: Available fire rated supply and return hoses

Description	Connection Size (O.D.)	Length
Supply and Return Hoses	1/2"	24"
		36"
	3/4"	24"
		36"
	1"	24"
		36"

Supply and Return Hose Kits

Figure 3: Supply and return hoses



Supply Hose - Combination Ball Valve and Strainer

The supply valve body is a combination Y-strainer full port shut-off valve and union for use in HVAC systems. Strainers are furnished with a 20 mesh stainless steel screen, hose end drain (blow down) valve for purging, one pressure/temperature port for commissioning, and one plugged bypass port. Three additional 1/4" taps are plugged and available for accessories when specified. A variety of pipe connections are available on both the fixed and union ends. Standard end connections are female pipe thread.

Shutoff Ball Valves with Memory Stop

Constructed of brass and rated at 400 psig (2758 kPa) maximum working pressure. Valves have a built-in adjustable memory stop to eliminate rebalancing. Valves have FPT connections on both ends for connection to the water hose and to the field piping.

Figure 4: Shutoff ball valve with memory stop



Wall-Mounted Programmable Electronic Thermostats for MicroTech III Unit Controller – Standalone Operation

For 2-stage or 3-stage heating, 2-stage or 3-stage cooling, dehumidification, and boilerless electric heat control. These electronic, programmable and Wi-Fi thermostats provide simple control capabilities, with alarm fault clearing, a timed override button and unit status LED. They easily interface to the MicroTech III SmartSource controller for both automatic and manual changeover capability, and can be connected to the accessory remote temperature sensor.

Note: See Table 4 on page 16 for Thermostat specific features and applications.



Programmable Electronic Thermostats

- 2 Heat/2 Cool, 7-Day Programmable, Auto Changeover, Hardwired – P/N 910193126
- 2 Heat/3 Cool, 7-Day Programmable, Auto Changeover, Hardwired – P/N 910193127
- 3 Heat/2 Cool, 7-Day Programmable, Auto Changeover, Hardwired – P/N 910193128
- 2 Heat/2 Cool, 7-Day Programmable, Dehumidification, Auto Changeover, Hardwired – P/N 910193129

Wi-Fi Programmable Electronic Thermostats

- 2 Heat/2 Cool, 7-Day Programmable, Auto Changeover, Hardwired – P/N 910193131
- 2 Heat/3 Cool, 7-Day Programmable, Auto Changeover, Hardwired – P/N 910193132
- 3 Heat/2 Cool, 7-Day Programmable, Auto Changeover, Hardwired – P/N 910193133
- 2 Heat/2 Cool, Dehumidification, 7-Day Programmable, Auto Changeover, Hardwired – P/N 910193134

Programmable and Non-Programmable Thermostats, 2 Stage Heat/2 Stage Cool

Note: Refer to 910121748 and 910121746 Install Manuals for details



Programmable

Non-Programmable

For 2-stage heating, 2-stage cooling, both the Programmable and Non-Programmable thermostats provide simple control capabilities. With alarm fault clearing, a timed override button and unit status LED, these thermostats provide an easy interface to the MicroTech III unit controls for both automatic and manual changeover capabilities. Each can be connected to the accessory remote temperature sensor.

Remote Room Sensor used with the Programmable and Non-Programmable Thermostats



The remote indoor temperature sensor provides the ability to measure room temperature remotely, from the thermostat location.

Room Temperature Sensors for MicroTech Unit Controller – Building Automated System (BAS) Operation

A MicroTech Water Source Heat Pump Room Temperature Sensor is required when connecting a Compact GCH unit to a Building Automation System (BAS) using either the LONWORKS or BACnet Communication Module. All MicroTech water source heat pump room temperature sensors provide electronic sensing of the room temperature for single or multiple-stage cooling and heating control, unit status annunciation, timed tenant override, and fault clearing capabilities.

Digitally Adjustable Display Sensor

Note: Refer to IM 1171 for details



The display sensor is used in conjunction with MicroTech equipped units. This digitally adjustable sensor displays room temperature, room humidity, fan speed (AUTO/ON), system mode (HEAT/COOL/AUTO/OFF/DHUM), ALARM, Override and occupancy.

De-humidification output contact has an adjustable set-point and configurable deadband.

This output operates automatically using the RH setpoint and deadband in the system "AUTO" mode or in the "DHUM" mode.

Digitally Adjustable Display Sensor

Note: Refer to IM 1237 for details



The display sensor is used in conjunction with MicroTech equipped units. The sensor has a digital display for temperature, occupancy, alarm, setpoint and status indication. Controls include four buttons for setpoint, occupied/unoccupied request, and override reset.

Basic Room Sensor

Note: Refer to IM 1238 for details



The basic room sensor is used in conjunction with MicroTech equipped units. The sensor has an output for temperature, and LED status indication and includes an override reset button.

Basic Room Sensor With Cool to Warm

Note: Refer to IM 1238 for details



The basic room sensor with adjustment (cool to warm) is used in conjunction with MicroTech equipped units. The sensor has an output for temperature, and LED status indication and includes an override reset button.

Adjustable Cool/Warm Sensor with Occupancy Switch



The Adjustable Cool/Warm Sensor with Occupancy Switch can be used for 2-stage heating, 2-stage cooling. Unit status is provided through a flashing LED located on the sensor while timed tenant override and fault reset are provided through the override button.

Changing the system mode, fan mode and occupancy is easily accomplished through the slider switches.

Adjustable 55° to 95°F or +/-3°F Sensors



Adjustable 55° to 95°F Sensor

The adjustable 55° to 95°F or +/- 3°F sensors can be used for 2-stage heating, 2-stage cooling. Unit status is provided through a flashing LED located on the sensor while timed tenant override and fault reset are provided through the override button. Changing the system or fan mode is easily accomplished through the slider switches.



+/-3°F Sensor

Basic Sensor



The basic sensor provides simple room temperature sensing for 2-stage heating, 2-stage cooling applications. Unit status is provided through a flashing LED located on the sensor while timed tenant override and fault reset are provided through the override button.

CAUTION

When an optional wall-mounted room temperature sensor is connected to the unit controller, the Return Air Temperature (RAT) sensor MUST NOT be installed. A wall-mounted room temperature sensor and the return air temperature sensor must not be connected simultaneously or the unit will not operate properly.

Table 4: Thermostats & remote room sensors for standalone operation









	Thermostats						Remote Room Sensor		
	Programmable / Non-Programmable				Non-Programmable	Programmable			
Thermostats & Remote Sensors Used with MicroTech III –Standalone Operation									
	Part #: 910193126 Part #: 910193131	Part #: 910193127 Part #: 910193132	Part #: 910193128 Part #: 910193133	Part #: 910193129 Part #: 910193134	Part #: 910121746	Part #: 910121748	Part #: 667720401	Part #: 107096001	Part #: 107096010
Feature	Used With Thermostats								
Standard									
Wi-Fi									
Display	Room Temp. & Setpoint	●	●	●	●	●			
	Room Humidity & Setpoint				●				
Changeover	Manual	●	●	●	●	●			
	Automatic								
Stages	Heating	2	2	3	2	2			
	Cooling	2	3	2	2	2			
Operating Modes	System	Cool-Off-Heat-Auto	Cool-Off-Heat-Auto	Cool-Off-Heat-Auto	Cool-Off-Heat-Auto	Cool-Off-Heat-Auto			
	Fan	On-Auto-Hourly	On-Auto-Hourly	On-Auto-Hourly	On-Auto-Hourly	On-Auto			
Annunciation	Status LED 5VDC					●			910193126
	Alarm Fault LED 24 VAC	●	●	●	●	●			910193127
Reset	Alarm	●	●	●	●	●			910193128
	Override	●	●	●	●	●			910193129
	Indoor	●	●	●	●	●			910193131
Remote Sensors									910193132
Application	Smart Dehumid.					●			910193133
	Simplified		●						910193134
Dehumidification	Humidistat Controlled				●				
	Dehumid. Only					●			
Electric Heat	Boilerless	●	●	●	●	●			
	Supplemental	●	●	●	●	●			
	Primary	●	●	●	●	●			
	Emergency	●	●	●	●	●			
Waterside Economizer		●	●	●	●	●			
Hydronic Heat		●	●	●	●	●			

Table 5: Room temperature sensors for BAS operation







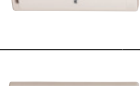

Sensors used with Compact GCH Units – Building Automated System (BAS) Operation		Room Temperature Sensors			
		Digitally Adjustable	Digitally Adjustable Display Sensor	Basic Room Sensor With Cool to Warm Adjust	Basic Room Sensor
					
With Temperature & Humidity Display for Smart Dehumidification or Waterside Economizer Operation	With Temperature Display, Indicates, ALARM, Override and Occupancy.	Senses Temperature, With Temperature Adjust Cool to Warm, LED Status Indication, Override Reset Button	Senses Temperature, LED Status Indication, Override Reset Button		
	Part No. 910121754	Part No. 910152147	Part No. 910171464	Part No. 910152149	
Feature					
Setpoint Adjustment		Digitally Adjustable	Digitally Adjustable	Cool to Warm	None
Display	Room Temperature & Setpoint	●	●		
	Room Humidity & Setpoint	●			
Stages	Heating	4	4	4	4
	Cooling	3	3	3	3
Operating Modes	System	Heat-Cool-Auto-Off-Dehum			
	Fan	Auto-On			
	Occupancy	LCD Display of Occupied-Unoccupied Icon	LCD Display of Occupied-Unoccupied Icon		
Annunciation	Status LED	LCD Display of Unit Status	LCD Display of Unit Status	●	●
	LCD Alarm Display	●	●		
Reset	Alarm	●	●	●	●
	Setback Override	●	●	●	●
Application					
Dehumidification		●			
Electric Heat	Boilerless	●	●	●	●
	Supplemental	●	●	●	●
	Primary	●	●	●	●
Waterside Economizer	–	●	●	●	●
Hydronic Heat	–	●	●	●	●

Table 6: Room temperature sensors for BAS operation

Sensors used with Compact GCH Units – Building Automated System (BAS) Operation		Room Temperature Sensors			
		Adjustable Cool/Warm with Occupancy Switch  Part No. 910121753	Adjustable 55°F to 95°F  Part No. 669529101	Adjustable +/- 3°F (+/- 1.5°C)  Part No. 669529201	Basic Sensor  Part No. 669529001
Feature					
Setpoint Adjustment		Cool to Warm	55°F to 95°F (13° to 35°C)	-3° to +3°F (-1.5° to +1.5°C)	None
Display	Room Temperature & Setpoint				
	Room Humidity & Setpoint				
Stages	Heating	4	4	4	4
	Cooling	3	3	3	3
Operating Modes	System	Cool-Auto-Heat	Cool-Auto-Heat	Cool-Auto-Heat	
	Fan	Auto-On	Auto-On	Auto-On	
	Occupancy	Occ-Unoc-Off			
Annunciation	Status LED	●	●	●	●
	LCD Alarm Display				
Reset	Alarm	●	●	●	●
	Setback Override	●	●	●	●
Application					
Dehumidification					
Waterside Economizer	–	●	●	●	●
Electric Heat	Boilerless	●	●	●	●
	Supplemental	●	●	●	●
	Primary	●	●	●	●
Hydronic Heat	–	●	●	●	●

Typical Horizontal Installation

Unit Location

It is important to leave enough space for service personnel to perform maintenance or repair. Locate the horizontal unit to allow for easy removal of the filter and access panels. Allow a minimum of 18" (46 cm) clearance on each side of the unit for service and maintenance access and do not install the unit above any piping. Always be sure to leave at least one side of the filter rack unobstructed so that the service personnel will be able to slide the filter out. Each unit is suspended from the ceiling by four 3/8" threaded rods fastened to the unit by a hanger bracket and rubber isolator. The design should place the unit directly below the structural members so that it is securely anchored. The unit should be hung level as the drain pan is internally pitched.

Avoid installing units directly above spaces where building occupants will reside (e.g. above office desks or classrooms) to reduce the requirement for noise attenuation. Do not place units above high traffic areas because service access may be limited during occupied hours. For example, units are typically installed above the hallway drop ceiling in schools and the supply and return air is routed directly into classrooms. Local code may require fire dampers to be used with this application.

1. Discharge air
2. Return air
3. Acoustic thermal duct lining - 10 feet
4. Low voltage wiring to unit control box
5. Line voltage to optional non-fused disconnect switch
6. Flexible duct collar(s)
7. Condensate drain with trap
8. Flexible, braided, stainless steel return hose with flow controller/ball valve with port
9. Flexible, braided, stainless steel supply hose with Y-strainer/ball valve with port
10. Access to unit control box
11. LED annunciator lights sight glass to view unit operation status and faults

Figure 5: Typical ceiling installation

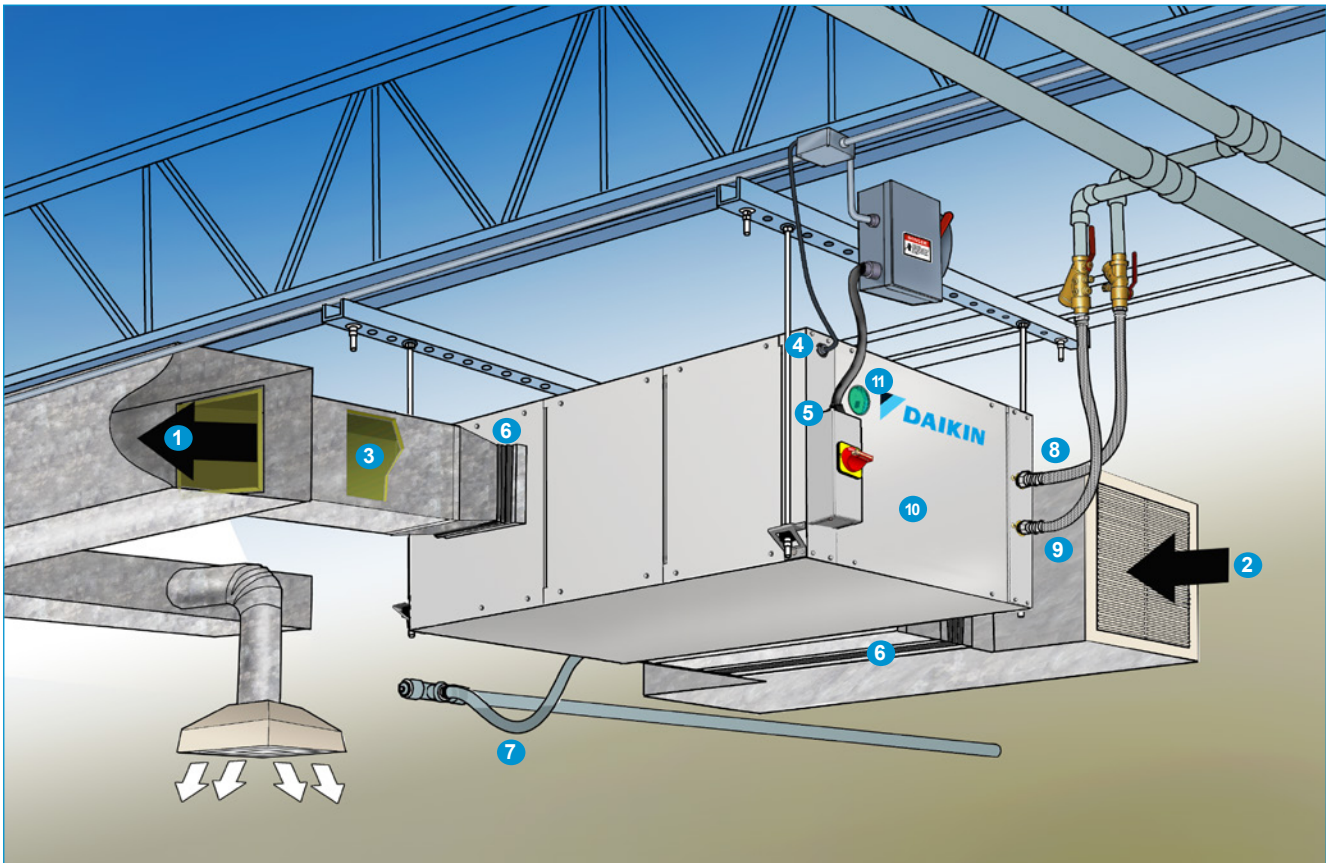

Ductwork and Attenuation

Horizontal Unit

Ductwork is normally applied to ceiling-mounted heat pumps on the discharge side of the unit. A discharge collar is provided on all horizontal unit models for fastening the ductwork. Use a flexible connector between the discharge collar and the duct transformation to help reduce vibration transmission from the cabinet and to simplify disconnection of the unit from the ceiling ductwork. If return ductwork is to be used, attach a flexible connector to the filter rack collar to help reduce vibration transmission and removal of the unit. Return plenum ducting should be at least 12 inches away from the coil so that the coil is evenly loaded with return air.

As a general recommendation, duct interiors should have an acoustic / thermal lining at least 1/2 inch thick over the entire duct run. For better sound attenuation, line the last five diameters of duct before each register with a one-inch thick sound blanket. Elbows, tees and dampers can create turbulence or distortion in the airflow. Place a straight length of duct, 5 to 10 times the duct width, before the next fitting to smooth out airflow. Diffusers that are located in the bottom of a trunk duct can also produce noise. For this same reason, volume control dampers should be located several duct widths upstream from an air outlet.

Figure 6: Horizontal unit duct example

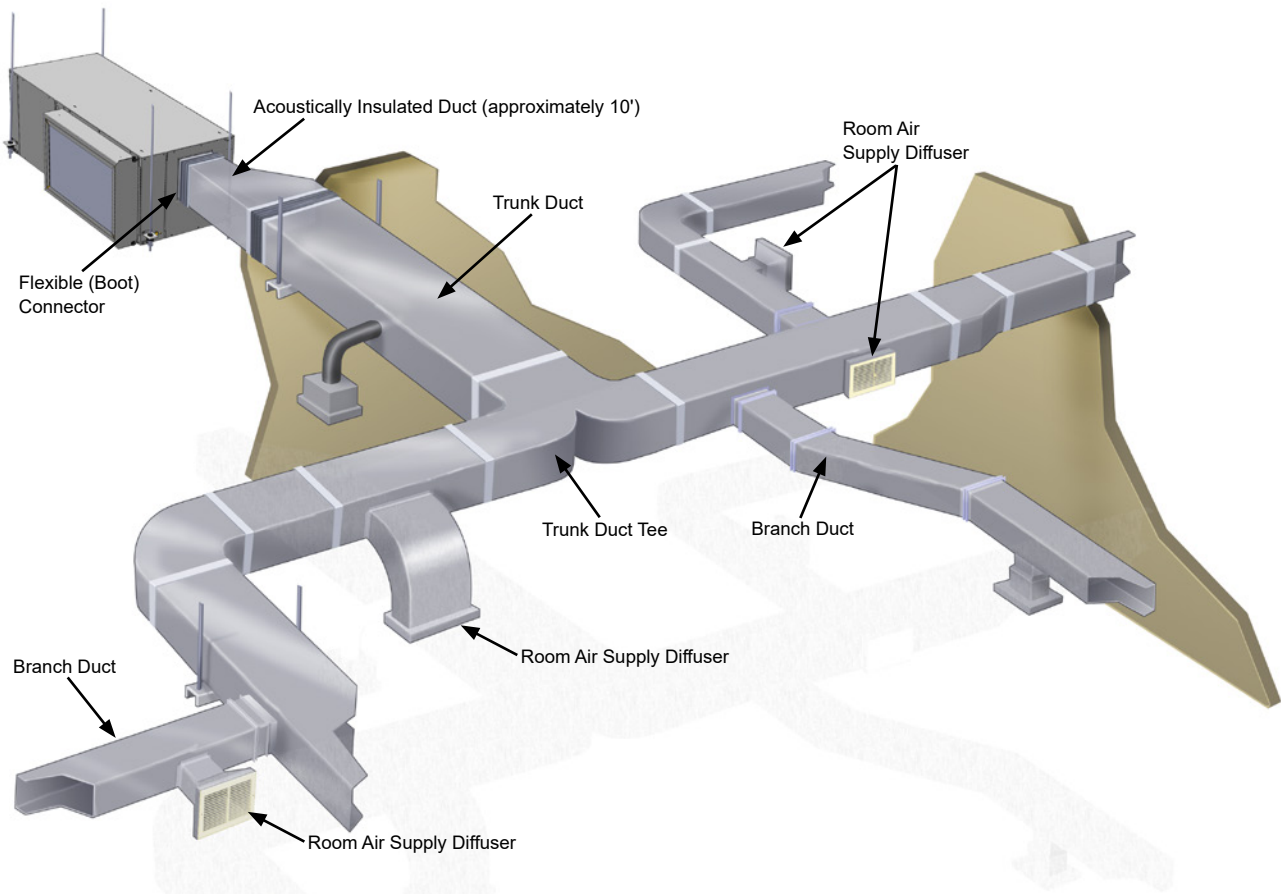

Piping

The water source heat pump unit is typically connected to the supply / return piping using a “reverse return” piping system which includes a flow control device so that flow requirements are met for each zone. A short, high pressure “flexible hose” is used to connect the unit to the building’s hard piping and acts as a sound attenuator for both the unit operating noise and hydronic pumping noise. One end of the hose has a swivel fitting to facilitate removal of the unit for replacement or service. Include supply and return shutoff valves in the design to allow removal of a unit without the need to shut down the entire heat pump system. The return valve may be used for balancing and will typically have a “memory stop” so that it can be reopened to the proper position for the flow required. Fixed flow devices are commercially available and can be installed to eliminate the need for memory stop shut off valves. Include Pressure / Temperature ports to allow the service technician to measure water flow and unit operation.

Daikin has available optional hose kit combinations to better facilitate system flow balancing. These flexible hoses reduce vibration between the unit and the rigid piping system.

Polyolester Oil, commonly known as POE oil is a synthetic oil used in many refrigeration systems. POE oil, if ever in contact with PVC/CPVC will coat the inside wall of PVC/CPVC pipe causing environmental stress fractures.

Please keep this in mind when selecting piping materials for your application, as system failure and property damage could result. For these reasons Daikin Applied does not recommend the use of PVC/CPVC water piping.

Figure 7: Reverse return piping system

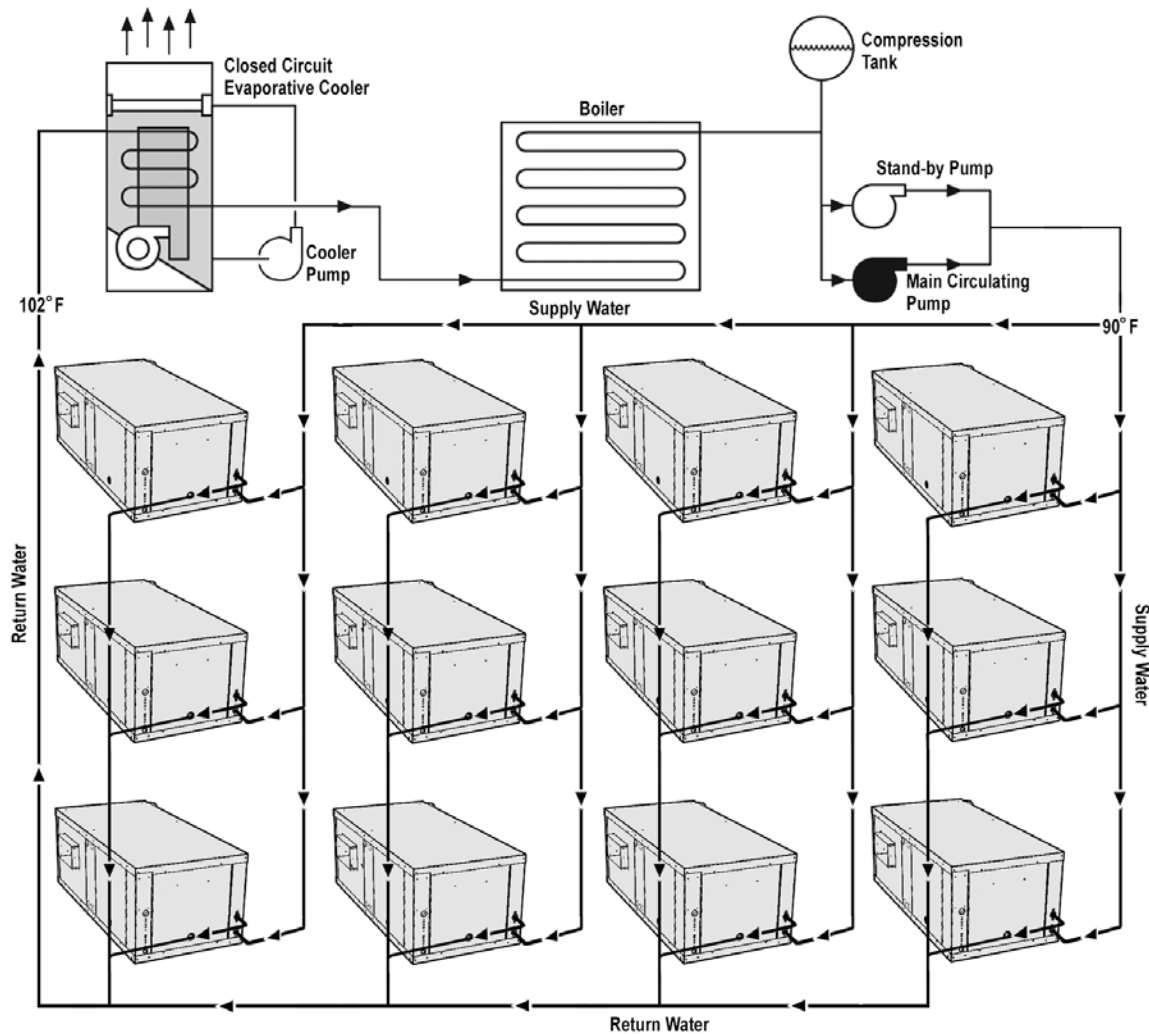

Water System Quality

The cleaning, flushing and chemical treatment of a water source heat pump system is fundamental to efficient operation and the life expectancy of the system.

Potential system problems produced by the use of water fall into three general categories:

1. **Scale formation** – Mineral deposits which result from the crystallization and precipitation of dissolved salts in the water. The deposits form an insulating barrier, reducing the heat transfer rate and impeding the circulation of fluids due to increased pressure drop.
2. **Corrosion** – Decomposition of the metal caused by absorption of gases from the air. Corrosion may occur in any metal component of the system.
3. **Organic growths** – Slime and algae which form under certain environmental conditions, and can reduce the heat transfer rate by forming an insulating coating or can promote corrosion by pitting.

The system water should be evaluated for degrees of impurity, with testing available from independent testing labs, health departments or state agencies.

Table 7 is a list of water characteristics, the potential impurities and their results and the recommended treatment.

Avoiding Potential Problems

As shown in Table 7, all water contains some degree of impurities which may affect the performance of a heat pump system. The use of a cupro-nickel coil can help avoid potential problems. Water flow rates should:

- A. Be high enough that the temperature rise through the heat exchanger does not exceed 10° F when operating in the cooling mode.
- B. Not exceed 4 GPM per nominal ton. Flow rates that have velocities of 10 feet per second or more may cause pipe erosion and heat exchanger failure.

Table 7: Water impurities, result & recommended water system application

Impurity	Copper Coils	Cupro-nickel Coils	Result	Application	
				Open Recirculating	Closed Recirculating
Calcium & Magnesium Salts (hardness)	Less than 350 ppm	350 ppm Sea Water	Scaling	1. Bleed-off 2. Surface active agents such as polyphosphates. 3. Addition of acid. 4. pH adjustment. <i>Other considerations:</i> <ul style="list-style-type: none"> ▪ Adequate fouling factor ▪ Surface temperature ▪ Water temperature ▪ Clean system 	No treatment required
Ironoxide	Low levels only	Moderate levels	Corrosion	1. Corrosion inhibitors in high concentrations (200 to 500 ppm). 2. Corrosion inhibitors in low concentrations (20 to 80 ppm). 3. pH control. 4. Proper materials of construction.	Corrosion inhibitors in high concentrations. Proper materials of construction.
pH	7 - 9	5 - 10			
Hydrogen Sulfide	Less than 10 ppm	10 - 50 ppm			
C_{o2}	Less than 50 ppm	50 - 75 ppm			
Chloride	Less than 300 ppm	300 - 600 ppm			
Total Dissolved Solids	Less than 1000 ppm	1000 - 1500 ppm			
Slime & Algae	Slime and algae can form under certain environmental conditions		Reduced heat transfer due to forming of insulating coating, or pitting due to corrosion	Chlorinated phenols. Other biocides. Chlorine by hypochlorites or by liquid chlorine	No treatment required

- Notes:**
1. The tremendous variety in water quality around the country makes the recommendation of a single best method of treatment impossible. Consult a local water treatment specialist for specific treatment recommendations.
 2. Cupro-Nickel is recommended if iron bacteria is present, suspended solids or dissolved oxygen levels are high.
 3. If the concentration of these corrosives exceeds the maximum tabulated in the cupro-nickel column, then the potential for serious corrosion problems exists.

Condensate Drain

Compact horizontal units have a 3/4-inch FPT condensate drain connection, flush to the unit. The drain pan is internally pitched. The field installed condensate piping must include a trap after the connection and be pitched away from the unit not less than 1/4" per foot. A vent is required after the trap so that the condensate will drain away from the unit. The vent can also act as a clean out if the trap becomes clogged. To avoid having waste gases entering the building, the condensate drain should not be directly piped to a drain/waste/vent stack. See local codes for the correct application of condensate piping to drains.

Improper trapping can lead to several problems. If the trap is too tall, negative pressure will prevent drainage, causing condensate backup. If the trap is too short the seal will be destroyed or nonexistent, producing the same effect as a non-trapped system.

Construct the trap of 7/8" clear plastic piping. The condensate piping from the drain trap must be sloped to facilitate proper drainage. The clear plastic trap should be clamped and removable for cleaning. It may be necessary to manually fill the trap at system startup, or to run the unit for sufficient time to build a condensate seal. The condensate trap and condensate piping drainage should be free of any foreign debris. Debris can prevent proper drainage and unit operation and result in condensate buildup.

Operating Limits

Table 8: Air limits in °F (°C)

Air Limits	Standard Range Units		Extended Range (Geothermal) Units	
	Cooling (DB/WB)	Heating	Cooling (DB/WB)	Heating
Minimum Ambient Air ¹	50°F (10°C)	50°F (10°C)	40°F (4°C)	40°F (4°C)
Maximum Ambient Air ²	100°F/77°F (38°C/25°C)	85°F (29°C)	100°F/77°F (38°C/25°C)	85°F (29°C)
Minimum Entering Air ¹	65°F/55°F (18°C/13°C)	50°F (10°C)	65°F/55°F (18°C/13°C)	50°F (10°C)
Common Design Entering Air	75°F/63°F (24°C/17°C)	70°F (21°C)	75°F/63°F (24°C/17°C)	70°F (21°C)
Maximum Entering Air ²	85°F/71°F (29°C/22°C)	80°F (27°C)	85°F/71°F (29°C/22°C)	80°F (27°C)

Table 9: Fluid limits

Fluid Limits	Standard Range Units		Extended Range (Geothermal) Units	
	Cooling	Heating	Cooling	Heating
Minimum Entering Fluid	55°F (13°C)	55°F (13°C)	30°F (-1°C)	20°F (-6°C)
Common Design Entering Fluid	85-90°F (29-32°C)	70°F (21°C)	90°F (32°C)	35-60°F (1.5-16°C)
Maximum Entering Fluid	120°F (43°C)	90°F (32°C)	120°F (43°C)	90°F (32°C)
Minimum GPM/Ton	1.5			
Nominal GPM/Ton	3.0			
Maximum GPM/Ton	4.0			

- Notes:**
- ¹ Maximum and minimum values may not be combined. If one value is at maximum or minimum, the other two conditions may not exceed the normal condition for standard units. Extended range units may combine any two maximum conditions, but not more than two, with all other conditions being normal conditions.
 - ² This is not a normal or continuous operating condition. It is assumed that such a start-up is for the purpose of bringing the building space up to occupancy temperature.
 - ³ Unit with waterside economizer option can operate in economizer cooling mode down to 40°F (4°C).

Fan Performance for Standard PSC Motor – 208V Operation

Table 10: PSC motor CFM values

Unit Size	Setting	Rated Airflow	External Static Pressure (in-H ₂ O) [Dry Coil and Standard Filter] (inches of water column)													
			.05	.10	.20	.30	.40	.45	.50	.60	.70	.80	.90	1.0	1.1	1.2
007	High	250	430	422	407	389	364	349	331	288	233					
	Medium		347	340	327	312	291	278	262	224	177					
	Low		302	295	282	266	245	233	218	183						
009	High	300	430	422	407	389	364	349	331	288	233					
	Medium		347	340	327	312	291	278	262	224						
	Low		302	295	282	266	245	233	218							
012	High	400	430	422	407	389	364	349	331	288						
	Medium		347	340	327	312	291									
	Low		302	295	282											
015	High	500	906	886	862	830	769	723	667	525	352					
	Medium		730	715	695	666	611	571	522	401						
	Low		655	642	621	587	524	481	431							
019	High	600	924	912	873	832	791	768	739	647	469					
	Medium		734	719	700	674	626	591	548	439						
	Low		659	648	627	591	529	489	443							
024	High	800	967	958	945	925	885	855	817	718	591					
	Medium		829	826	824	814	783	757	723	633						
	Low		703	704	708	703	680	659	632							
030	High	1000	1307	1280	1210	1136	1066	1031	995	906	769					
	Medium		1274	1249	1181	1107	1039	1006	972	885	745					
	Low		1220	1198	1136	1069	1005	973	939	853	713					
036	High	1200	1517	1455	1399	1382	1352	1321	1274	1130	914					
	Medium		1450	1404	1353	1321	1278	1243	1198	1068	880					
	Low		1335	1303	1269	1246	1207	1176	1134	1014	841					
036 (265V)	High	1200	1453	1425	1352	1271	1192	1151	1106	994						
	Medium		1384	1360	1298	1228	1155	1116	1073	963						
	Low		1282	1267	1217	1157	1094	1060	1022	922						
042 (208V)	High	1400	1641	1615	1587	1570	1545	1523	1494	1407	1277	1101				
	Medium		1442	1430	1425	1423	1405	1385	1357	1268	1138					
	Low		1245	1244	1245	1246	1235	1223	1205	1144	1042					
042 (460V)	High	1400	1754	1732	1693	1654	1607	1577	1541	1446	1312	1125				
	Medium		1615	1594	1573	1557	1528	1503	1470	1372	1230	1042				
	Low		1456	1441	1432	1429	1407	1386	1354	1260	1125					
048	High	1600	1789	1780	1751	1713	1668	1644	1618	1559	1483	1379	1230			
	Medium		1492	1499	1490	1467	1440	1426	1412	1378	1325	1234				
	Low		1256	1265	1268	1261	1252	1246	1238	1214	1162					
060	High	2000	2356	2323	2261	2199	2126	2084	2038	1930	1804	1661	1507			
	Medium		2132	2109	2066	2020	1963	1928	1889	1795	1682	1553	1415			
	Low		1861	1848	1823	1793	1750	1722	1690	1612	1516	1406				
070	High	2300	2539	2533	2518	2498	2470	2452	2430	2377	2309	2223	2121	2001	1864	1710
	Medium		2177	2175	2169	2161	2146	2137	2124	2093	2049	1991	1918	1827	1716	
	Low		1873	1872	1868	1861	1849	1841	1832	1809	1777	1734				

- Notes:**
1. Speed adjustment is done at terminal strip on the motor. Refer to unit schematic.
 2. Gray tinted areas, outside recommended operating range.
 3. Refer to schematic supplied with the unit for wiring as supplied by the factory. Wire colors BK = hi, BL = med & RD = low.

Fan Performance For Optional Constant Torque EC Motor (Sizes 007–012)

Table 11: Constant torque EC motor CFM values

Unit Size	Setting	Function	External Static Pressure (in-H ₂ O) [Dry Coil and Standard Filter] (inches of water column)												
			0.1	0.15	0.2	0.25	0.3	0.35	0.4	0.45	0.5	0.55	0.6	0.65	0.7
007	Setting 4	Stage 1	324	311	297	281	266	250	236	221	208	194	180	165	
	Setting 3		300	286	270	252	235	218	202	186	172				
	Setting 2		274	259	242	223	204	185	167						
	Setting 1		274	259	242	223	204	185	167						
	Setting 4	Stage 2	345	335	324	312	299	285	270	255	239	223	206	190	174
	Setting 3		324	311	297	281	266	250	236	221	208	194	180	165	
	Setting 2		300	286	270	252	235	218	202	186	172				
	Setting 1		274	259	242	223	204	185	167						
	A	Fan Only, and WSE	274	259	242	223	204	185	167						
	B		274	259	242	223	204	185	167						
	C		231	213	192	171									
	D*		231	213	192	171									
009	Setting 4	Stage 1	357	348	337	326	314	301	287	272	257	240	224		
	Setting 3		330	318	304	290	275	260	245	231	216				
	Setting 2		296	282	266	248	231	213							
	Setting 1		296	282	266	248	231	213							
	Setting 4	Stage 2	385	375	365	354	342	330	319	306	294	281	267	252	236
	Setting 3		357	348	337	326	314	301	287	272	257	240	224		
	Setting 2		330	318	304	290	275	260	245	231	216				
	Setting 1		296	282	266	248	231	213							
	A	Fan Only, and WSE	296	282	266	248	231	213							
	B		296	282	266	248	231	213							
	C		246	228											
	D*		246	228											
012	Setting 4	Stage 1	409	399	388	376	365	354	344	333	323	312	300	287	
	Setting 3		376	366	356	345	333	321	308	295	281				
	Setting 2		345	335	324	312	299	285							
	Setting 1		345	335	324	312	299	285							
	Setting 4	Stage 2	449	438	426	414	403	392	381	372	362	353	343	331	317
	Setting 3		409	399	388	376	365	354	344	333	323	312	300	287	
	Setting 2		376	366	356	345	333	321	308	295	281				
	Setting 1		345	335	324	312	299	285							
	A	Fan Only, and WSE	345	335	324	312	299	285	270	255	239	223	206	190	
	B		345	335	324	312	299	285	270	255	239	223	206	190	
	C		296	282	266	248	231	213	197	181					
	D*		296	282	266	248	231	213	197	181					

Notes: 1. Gray tinted areas, outside recommended operating range.

2. Units are shipped at setting 3 (standard). Speed adjustment is done by 4-position switch in the control box.

3. The unit is capable of high-low fan performance through the use of a 2-stage thermostat wired to specific terminals for High-Low CFM fan performance. Standard operation with a 1-stage thermostat is indicated as stage 2 fan performance.

* Exception - WSE operates at row "C" airflows.

Note: See Table 14 on page 28 for jumper configuration location.

Fan Performance For Optional Constant Torque EC Motor (Sizes 015–070)

Table 12: Constant torque EC motor CFM values

Unit Size	Setting	Rated Airflow	External Static Pressure (in-H ₂ O) [Dry Coil and STD Filter] (inches of water column)											
			.05	.10	.20	.30	.40	.45	.50	.60	.70	.80	.90	1.0
015	Setting 5 (High)	500	810	784	761	754	741	728	708	644	547	420		
	Setting 4 (High)		765	745	709	675	639	620	598	549	489	415		
	Setting 3 (Standard)		694	679	639	592	543	518	494	446	397			
	Setting 2 (Medium)		632	602	549	500	452	427	402					
	Setting 1 (Low)		576	537	463	397								
019	Setting 5 (High)	600	881	851	833	838	835	824	803	730	613	460		
	Setting 4 (High)		822	796	768	752	734	720	700	644	562	454		
	Setting 3 (Standard)		751	729	697	670	639	620	598	541	467			
	Setting 2 (Medium)		685	668	628	584	539	516	494	447				
	Setting 1 (Low)		631	609	554	495	436							
024 208/230V & 277V	Setting 5 (High)	800	1197	1183	1140	1086	1029	999	968	896	798	654		
	Setting 4 (High)		1068	1056	1034	1010	980	962	939	875	779	637		
	Setting 3 (Standard)		932	918	883	852	830	821	812	787	730	610		
	Setting 2 (Medium)		893	882	843	804	778	771	765	747	688			
	Setting 1 (Low)		830	814	775	738	710	699	689	663	611			
024 460V	Setting 5 (High)	800	1272	1243	1181	1113	1042	1005	965	877	770	633		
	Setting 4 (High)		1063	1052	1032	1011	978	955	927	851	744	604		
	Setting 3 (Standard)		925	912	883	855	831	819	806	772	710	601		
	Setting 2 (Medium)		874	861	833	804	776	762	748	718	683	636		
	Setting 1 (Low)		819	805	776	745	714	699	683	652	619	582		
030	Setting 5 (High)	1000	1222	1198	1142	1071	980	926	866	731				
	Setting 4 (High)		1198	1170	1123	1069	990	939	879	735				
	Setting 3 (Standard)		1187	1168	1125	1063	975	920	858	715				
	Setting 2 (Medium)		1085	1076	1058	1022	954	906	847	705				
	Setting 1 (Low)		1020	1013	1002	974	916	874	822					
036	Setting 5 (High)	1200	1480	1461	1404	1341	1282	1254	1223	1143	1009			
	Setting 4 (High)		1445	1434	1387	1328	1269	1240	1208	1128	997			
	Setting 3 (Standard)		1404	1393	1353	1305	1256	1231	1202	1123	991			
	Setting 2 (Medium)		1269	1256	1227	1201	1180	1168	1152	1098	984			
	Setting 1 (Low)		1222	1208	1171	1139	1118	1110	1101	1064	970			
042	Setting 5 (High)	1400	1868	1843	1777	1699	1613	1568	1522	1426	1321	1198	1048	
	Setting 4 (High)		1785	1774	1727	1658	1578	1536	1492	1401	1302	1185	1038	
	Setting 3 (Standard)		1532	1514	1491	1471	1446	1428	1406	1342	1251	1128		
	Setting 2 (Medium)		1482	1465	1437	1414	1390	1375	1358	1310	1239	1117		
	Setting 1 (Low)		1434	1420	1389	1358	1328	1314	1298	1262	1211	1091		
048	Setting 5 (High)	1600	1852	1841	1809	1775	1747	1735	1725	1704	1670	1601	1468	1236
	Setting 4 (High)		1811	1800	1764	1725	1692	1680	1669	1650	1621	1561	1438	1215
	Setting 3 (Standard)		1739	1731	1695	1651	1614	1601	1590	1574	1553	1507	1404	1206
	Setting 2 (Medium)		1683	1676	1637	1588	1548	1533	1523	1512	1501	1468	1377	1184
	Setting 1 (Low)		1635	1624	1581	1531	1489	1474	1464	1452	1441	1412	1334	1168
060	Setting 5 (High)	2000	2316	2298	2257	2208	2149	2114	2076	1988	1882	1756	1607	1432
	Setting 4 (High)		2246	2229	2195	2155	2105	2075	2040	1958	1856	1732	1586	1418
	Setting 3 (Standard)		2163	2145	2114	2083	2045	2021	1994	1926	1838	1725	1586	1421
	Setting 2 (Medium)		2101	2078	2040	2007	1974	1956	1935	1884	1815	1720	1594	1430
	Setting 1 (Low)		2019	2003	1966	1925	1885	1865	1845	1802	1751	1680	1579	1429
070	Setting 5 (High)	2300	2489	2467	2426	2387	2351	2333	2315	2276	2228	2164	2075	1950
	Setting 4 (High)		2474	2453	2413	2377	2342	2324	2305	2264	2212	2144	2053	1929
	Setting 3 (Standard)		2464	2444	2406	2370	2336	2319	2302	2263	2216	2152	2063	1939
	Setting 2 (Medium)		2408	2388	2345	2304	2265	2247	2229	2193	2151	2098	2023	1913
	Setting 1 (Low)		2310	2293	2256	2218	2181	2163	2145	2108	2066	2014	1944	1847

- Notes:**
1. Gray tinted areas, outside recommended operating range.
 2. Units are shipped at setting 3 (standard), setting 5 (high) for unit size 070. Speed adjustment is done at motor terminal strip
 3. Motor speed adjustments can be made by moving wire to appropriate motor tap 1-5.

Fan Performance For Optional Constant CFM EC Motor (Sizes 015–070)

Table 13: Single or two-stage units with constant CFM EC motor

Unit Size	MicroTech Unit Controller						I/O Expansion Module		
	Setting	Maximum ESP (in. wg.) ²	Heat/Cool Stage 1 + Hydronic Coil	Heat/Cool Stage 2	Dehumid	Electric Heat	Setting	Fan Only	Waterside Economizer
015	4 (High)	0.7	500	565	470	565	A	500	500
	3 (Standard)		435	500	405	565	B	435	435
	2 (Medium)		375	435	375	565	C	375	375
	1 (Low)		375	375	375	565	D	280	375
019	4 (High)	0.7	600	675	560	675	A	600	600
	3 (Standard)		525	600	485	675	B	525	525
	2 (Medium)		450	525	450	675	C	450	450
	1 (Low)		450	450	450	675	D	335	450
024	4 (High)	0.7	800	900	750	900	A	800	800
	3 (Standard)		700	800	650	900	B	700	700
	2 (Medium)		560	700	560	900	C	560	560
	1 (Low)		560	560	560	900	D	450	560
030	4 (High)	0.7 (except * = 0.5)	1000	1075*	935	1075*	A	1000	1000
	3 (Standard)		875	1000	810	1075*	B	875	875
	2 (Medium)		750	875	750	1075*	C	750	750
	1 (Low)		750	750	750	1075*	D	560	750
036	4 (High)	0.7	1200	1350	1125	1350	A	1200	1200
	3 (Standard)		1050	1200	975	1350	B	1050	1050
	2 (Medium)		900	1050	900	1350	C	900	900
	1 (Low)		900	900	900	1350	D	670	900
042	4 (High)	0.7	1400	1575	1310	1575	A	1400	1400
	3 (Standard)		1225	1400	1135	1575	B	1225	1225
	2 (Medium)		1050	1225	1050	1575	C	1050	1050
	1 (Low)		1050	1050	1050	1575	D	785	1050
048	4 (High)	0.7	1600	1800	1500	1800	A	1600	1600
	3 (Standard)		1400	1600	1300	1800	B	1400	1400
	2 (Medium)		1200	1400	1200	1800	C	1200	1200
	1 (Low)		1200	1200	1200	1800	D	895	1200
060	4 (High)	0.7	2000	2250	1875	2250	A	2000	2000
	3 (Standard)		1750	2000	1625	2250	B	1750	1750
	2 (Medium)		1495	1750	1495	2250	C	1495	1495
	1 (Low)		1495	1495	1495	2250	D	1120	1495
070	4 (High)	0.7 (except * = 0.5)	2300	2450*	2155	2450*	A	2300	2300
	3 (Standard)		2010	2300	1865	2450*	B	2010	2010
	2 (Medium)		1720	2010	1720	2450*	C	1720	1720
	1 (Low)		1720	1720	1720	2450*	D	1290	1720

Table 14: I/O expansion module jumper configuration

I/O Expansion module configuration		
Setting	JP1	JP2
A	Open	Open
B	Shorted	Open
C	Open	Shorted
D	Shorted	Shorted

Note: Refer to [Figure 8](#) for jumper configuration location.

Figure 8: JP1 & JP2 location on the I/O expansion module

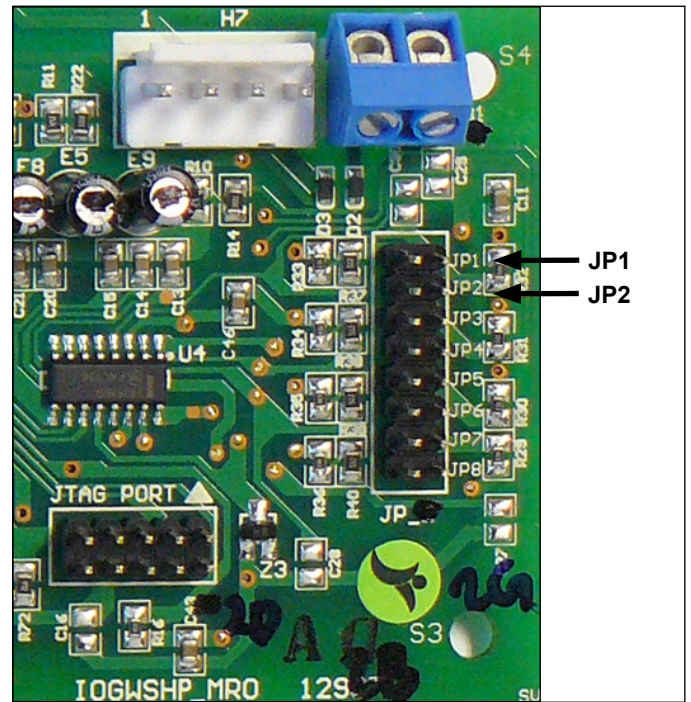

GCH Waterside Economizer Cooling Capacity

Table 15: Model GCH 250 to 600 CFM¹ – Unit Sizes 007 through 019

Unit Size	GPM	CFM										³ WPD ft. of wc.
		250		300		400		500		600		
		Total	Sensible	Total	Sensible	Total	Sensible	Total	Sensible	Total	Sensible	
007-12	1.5	5000	4600	5400	5100	6200	6100					0.3
	2	5800	5000	6200	5500	7000	6600					0.5
	3	7500	5900	7900	6400	8700	7400					1.2
	4	9200	6700	9600	7200	10400	8300					2.2
	² PD (" wc.)	0.03		0.04		0.06						
015-019	2					8100	7800	9000	8900	9900	10000	0.7
	3					9900	8600	10800	9700	11600	10800	1.5
	4					11700	9400	12500	10500	13400	11600	2.6
	5					13500	10200	14300	11300	15200	15400	4.1
	² PD (" wc.)					0.04		0.06		0.08		

Table 16: Model GCH, 600 to 1400 CFM¹ – Unit Sizes 024 through 042

Unit Size	GPM	CFM										³ WPD ft. of wc.
		600		800		1000		1200		1400		
		Total	Sensible	Total	Sensible	Total	Sensible	Total	Sensible	Total	Sensible	
024-030	4.5	15300	12700	17000	14700	18700	16700	20500	18700			0.8
	6	17400	13600	19100	15600	20900	17600	22600	19600			1.5
	7.5	19500	14600	21300	16600	23000	18600	24700	20600			2.5
	² PD (" wc.)	0.07		0.11		0.16		0.22				
036	6			20600	16600	22400	18600	24100	20500	25800	22400	1.6
	7.5			22600	17500	24300	19400	26000	21800	27800	23200	2.7
	9			24600	18300	26300	20200	28000	22100	29700	24000	4.0
	² PD (" wc.)			0.05		0.08		0.10		0.13		
042	8					26100	20300	27200	22100	29400	24000	3.1
	10.5					29100	21500	30700	23400	32400	25200	5.7
	12					30900	22300	32500	24100	34200	25900	7.6
	² PD (" wc.)					0.08		0.13		0.13		

Table 17: Model GCH, 1200 to 2000 CFM¹ – Unit Sizes 048 through 060

Unit Size	GPM	CFM										³ WPD ft. of wc.
		1200		1400		1600		1800		2000		
		Total	Sensible	Total	Sensible	Total	Sensible	Total	Sensible	Total	Sensible	
048	8	29100	23900	30900	25900	32700	27800					4.1
	10	31800	25000	33600	27000	35400	28900					6.0
	12	34400	26100	36200	28100	38000	30100					8.2
	² PD (" wc.)	0.08		0.10		0.12						
060	10					36900	30800	38500	32600	40100	34400	4.8
	12.5					39700	31900	41400	33700	43000	35500	7.8
	15					42600	33100	44200	34900	45800	36700	11.8
	² PD (" wc.)					0.12		0.15		0.17		

Table 18: Model GCH, 1600 to 2400 CFM¹ – Unit Size 070

Unit Size	GPM	CFM										³ WPD ft. of wc.
		1600		1800		2000		2200		2400		
		Total	Sensible	Total	Sensible	Total	Sensible	Total	Sensible	Total	Sensible	
070	12.5	42100	35500	43800	37200	45500	39000	47100	40700	48800	42500	7.8
	15	45100	36700	46800	38400	48500	40200	50100	4200	51800	43700	10.8
	18	48700	38100	50400	39900	52100	41700	53700	43400	55400	45200	14.8
	² PD (" wc.)	0.17		0.20		0.24		0.29		0.32		

Notes: ¹ Capacity is based on 80/67°F entering air and 45°F entering water temperatures. Total and sensible capacities are btuh.

² Air PD is air pressure drop in inches of water column wet coil.

³ WPD is water side pressure drop in feet of water. Coil pressure drop only.

Unit With Standard PSC Motor

Table 19: Unit with standard PSC motor

Unit Size	Power	Compressor		Fan Motor FLA	Total Unit FLA	Minimum Voltage	Minimum Circuit Amps	Maximum Fuse or HACR Breaker Size
	Voltage/Hz/Phase	RLA	LRA					
007	115/60/1	5.0	36.2	1.3	6.3	104	7.6	15
	208-230/60/1	2.5	17.7	0.8	3.3	197	3.9	15
	265-277/60/1	2.1	13.5	0.5	2.6	240	3.1	15
009	115/60/1	8.3	45.6	1.3	9.6	104	11.7	15
	208-230/60/1	4.0	22.0	0.8	4.8	197	5.8	15
	265-277/60/1	3.3	18.8	0.5	3.8	240	4.7	15
012	208-230/60/1	5.6	32.5	0.8	6.4	197	7.8	15
	265/60/1	4.7	20.0	0.5	5.2	240	6.4	15
015	115/60/1	10.5	54.5	1.0	11.5	104	14.1	20
	208-230/60/1	5.1	29.5	1.0	6.1	197	7.4	15
	265-277/60/1	4.3	23.5	1.0	5.3	240	6.4	15
019	208-230/60/1	6.2	31.5	1.0	7.2	197	8.8	15
	265-277/60/1	5.3	28.0	1.0	6.3	240	7.6	15
024	208-230/60/1	13.5	58.3	1.3	14.8	197	18.2	30
	265-277/60/1	9.0	54.0	1.0	10.0	240	12.3	20
	208-230/60/3	7.1	55.4	1.3	8.4	197	10.2	15
	460/60/3	3.5	28.0	0.6	4.1	416	5.0	15
030	208-230/60/1	14.1	73.0	3.3	17.4	197	20.9	30
	265-277/60/1	10.9	60.0	2.5	13.4	240	16.1	25
	208-230/60/3	8.9	58.0	3.3	12.2	197	14.4	20
	460/60/3	4.2	28.0	1.8	6.0	416	7.1	15
036	208-230/60/1	16.7	79.0	3.3	20.0	197	24.2	40
	265-277/60/1	13.5	72.0	2.5	16.0	240	19.4	30
	208-230/60/3	10.4	73.0	3.3	13.7	197	16.3	25
	460/60/3	5.8	38.0	1.8	7.6	416	9.1	15
042	208-230/60/1	17.9	112.0	3.3	21.2	197	25.7	40
	208-230/60/3	13.2	88.0	3.3	16.5	197	19.8	30
	460/60/3	6.0	44.0	1.8	7.8	416	9.3	15
048	208-230/60/1	21.8	117.0	3.3	25.1	197	30.6	50
	208-230/60/3	13.7	83.1	3.3	17.0	197	20.4	30
	460/60/3	6.2	41.0	1.8	8.0	416	9.6	15
	575/60/3	4.8	33.0	1.2	6.0	520	7.2	15
060	208-230/60/1	26.3	134.0	5.5	31.8	197	38.4	60
	208-230/60/3	15.6	110.0	5.5	21.1	197	25.0	40
	460/60/3	7.8	52.0	2.4	10.2	416	12.2	15
	575/60/3	5.8	38.9	1.7	7.5	520	9.0	15
070	208-230/60/1	30.8	178.0	5.5	36.3	197	44.0	60
	208-230/60/3	19.6	136.0	5.5	25.1	197	30.0	45
	460/60/3	8.2	66.1	2.4	10.6	416	12.7	20
	575/60/3	6.6	55.3	1.7	8.3	520	10.0	15

Unit With Optional EC Constant Torque Motor

Table 20: Unit with optional EC constant torque motor

Unit Size	Power	Compressor		Fan Motor FLA	Total Unit FLA	Minimum Voltage	Minimum Circuit Amps	Maximum Fuse or HACR Breaker Size
	Voltage/Hz/Phase	RLA	LRA					
007	115/60/1	5.0	36.2	1.8	6.8	104	8.0	15
	208-230/60/1	2.5	17.7	0.9	3.4	197	4.1	15
	265-277/60/1	2.1	13.5	0.8	2.9	240	3.4	15
009	115/60/1	8.3	45.6	1.8	10.1	104	12.1	20
	208-230/60/1	4.0	22.0	0.9	4.9	197	5.9	15
	265-277/60/1	3.3	18.8	0.8	4.1	240	4.9	15
012	208-230/60/1	5.6	32.5	0.9	6.5	197	7.9	15
	265-277/60/1	4.7	20.0	0.8	5.5	240	6.6	15
015	115/60/1	10.5	54.5	4.8	15.3	104	17.9	25
	208-230/60/1	5.1	29.5	2.9	8.0	197	9.3	15
	265-277/60/1	4.3	23.5	2.6	6.9	240	8.0	15
019	208-230/60/1	6.2	31.5	2.9	9.1	197	10.7	15
	265-277/60/1	5.3	28.0	2.6	7.9	240	9.2	15
024	208-230/60/1	13.5	58.3	2.9	16.4	197	19.8	30
	265-277/60/1	9.0	54.0	2.6	11.6	240	13.9	20
	208-230/60/3	7.1	55.4	2.9	10.0	197	11.8	15
	460/60/3	3.5	28.0	2.1	5.6	416	6.5	15
030	208-230/60/1	14.1	73.0	4.1	18.2	197	21.7	35
	265-277/60/1	10.9	60.0	3.6	14.5	240	17.2	25
	208-230/60/3	8.9	58.0	4.1	13.0	197	15.2	20
	460/60/3	4.2	28.0	2.1	6.3	416	7.4	15
036	208-230/60/1	16.7	79.0	4.1	20.8	197	25.0	40
	265-277/60/1	13.5	72.0	3.6	17.1	240	20.5	30
	208-230/60/3	10.4	73.0	4.1	14.5	197	17.1	25
	460/60/3	5.8	38.0	2.1	7.9	416	9.4	15
042	208-230/60/1	17.9	112.0	6.0	23.9	197	28.4	45
	208-230/60/3	13.2	88.0	6.0	19.2	197	22.5	35
	460/60/3	6.0	44.0	3.2	9.2	416	10.7	15
048	208-230/60/1	21.8	117.0	6.0	27.8	197	33.3	50
	208-230/60/3	13.7	83.1	6.0	19.7	197	23.1	35
	460/60/3	6.2	41.0	3.2	9.4	416	11.0	15
060	208-230/60/1	26.3	134.0	7.6	33.9	197	40.5	60
	208-230/60/3	15.6	110.0	7.6	23.2	197	27.1	40
	460/60/3	7.8	52.0	4.0	11.8	416	13.8	20
070	208-230/60/1	30.8	178.0	7.6	38.4	197	46.1	60
	208-230/60/3	19.6	136.0	7.6	27.2	197	32.1	50
	460/60/3	8.2	66.1	4.0	12.2	416	14.3	20

Unit With Optional EC Constant CFM Motor

Table 21: Unit with optional EC constant CFM motor

Unit Size	# Stages	Power	Compressor		Fan Motor FLA	Total Unit FLA	Minimum Voltage	Minimum Circuit Amps	Maximum Fuse or HACR Breaker Size		
		Voltage/Hz/Phase	RLA	LRA							
015	1	115/60/1	10.5	54.5	4.0	14.5	104	17.1	25		
		208-230/60/1	5.1	29.5	2.8	7.9	197	9.2	15		
		265-277/60/1	4.3	23.5	2.4	6.7	240	7.8	15		
019	1	208-230/60/1	6.2	31.5	2.8	9.0	197	10.6	15		
		265-277/60/1	5.3	28.0	2.4	7.7	240	9.0	15		
024	1	208-230/60/1	13.5	58.3	2.8	16.3	197	19.7	30		
		265-277/60/1	9.0	54.0	2.4	11.4	240	13.7	20		
		208-230/60/3	7.1	55.4	2.8	9.9	197	11.7	15		
		*460/60/3	3.5	28.0	2.4	5.9	416	6.8	15		
	2	208-230/60/1	11.7	58.3	2.8	14.5	197	17.4	25		
		265-277/60/1	9.1	54.0	2.4	11.5	240	13.8	20		
		208-230/60/3	6.5	55.4	2.8	9.3	197	10.9	15		
030	1	208-230/60/1	14.1	73.0	2.8	16.9	197	20.4	30		
		265-277/60/1	10.9	60.0	2.4	13.3	240	16.0	25		
		208-230/60/3	8.9	58.0	2.8	11.7	197	13.9	20		
		*460/60/3	4.2	28.0	2.4	6.6	416	7.7	15		
	2	208-230/60/1	13.1	73.0	2.8	15.9	197	19.2	30		
		265-277/60/1	10.2	60.0	2.4	12.6	240	15.2	25		
		208-230/60/3	8.7	58.0	2.8	11.5	197	13.7	20		
		*460/60/3	4.3	28.0	2.4	6.7	416	7.8	15		
		036	1	208-230/60/1	16.7	79.0	4.0	20.7	197	24.9	40
				265-277/60/1	13.5	72.0	3.4	16.9	240	20.3	30
208-230/60/3	10.4			73.0	4.0	14.4	197	17.0	25		
*460/60/3	5.8			38.0	3.4	9.2	416	10.7	15		
2	208-230/60/1		15.6	83.0	4.0	19.6	197	23.5	35		
	265-277/60/1		13.0	72.0	3.4	16.4	240	19.7	30		
042	1	208-230/60/1	17.9	112.0	5.9	23.8	197	28.3	45		
		208-230/60/3	13.2	88.0	5.9	19.1	197	22.4	35		
		*460/60/3	6.0	44.0	4.8	10.8	416	12.3	15		
	2	208-230/60/1	17.9	96.0	5.9	23.8	197	28.3	45		
		208-230/60/3	14.2	88.0	5.9	20.1	197	23.7	35		
		*460/60/3	6.2	44.0	4.8	11.0	416	12.6	15		
		048	1	208-230/60/1	21.8	117.0	5.9	27.7	197	33.2	50
	208-230/60/3			13.7	83.1	5.9	19.6	197	23.0	35	
	*460/60/3			6.2	41.0	4.8	11.0	416	12.6	15	
	2	208-230/60/1	21.2	104.0	5.9	27.1	197	32.4	50		
208-230/60/3		14.0	83.1	5.9	19.9	197	23.4	35			
*460/60/3		6.4	41.0	4.8	11.2	416	12.8	15			
060		1	208-230/60/1	26.3	134.0	7.4	33.7	197	40.3	60	
			208-230/60/3	15.6	110.0	7.4	23.0	197	26.9	40	
	*460/60/3		7.8	52.0	6.2	14.0	416	16.0	20		
	2	208-230/60/1	26.9	139.9	7.4	34.3	197	41.0	60		
		208-230/60/3	16.5	110.0	7.4	23.9	197	28.0	40		
		*460/60/3	7.2	52.0	6.2	13.4	416	15.2	20		
070	1	208-230/60/1	30.8	178.0	7.4	38.2	197	45.9	60		
		208-230/60/3	19.6	136.0	7.4	27.0	197	31.9	50		
		*460/60/3	8.2	66.1	6.2	14.4	416	16.5	20		
	2	208-230/60/1	29.7	179.2	7.4	37.1	197	44.5	60		
		208-230/60/3	17.6	136.0	7.4	25.0	197	29.4	45		
		*460/60/3	8.5	66.1	6.2	14.7	416	16.8	25		

Notes: *All 460/60/3 units require 4-wire power which includes a neutral wire providing 265 volts to the fan motor.

GCH Units

Table 22: Unit sizes 007 through 030

Description		Unit Size						
		007	009	012	015	019	024	030
Compressor Type		Rotary				Scroll		
Refrigeration Charge (Oz.)	Single Stage	16	208V-21.5 ozs		28	34	37	36
			265V-18 ozs					
	Two Stage	N/A				37	34	
HGRH Refrigeration Charge Adder (Oz.)		N/A			6	7		
Fan Wheel (D x W)		6" x 8"			9" x 7"			
PSC Fan Motor HP		1/8			1/6	1/4	1/3	
EC Constant Torque Motor HP		1/10			1/3	1/3 (1/2 for 460V)		
EC Constant CFM Motor HP		N/A			1/3	1/3		
Water Connection Size (FPT)		1/2"				3/4"		
Coax Volume (Gal. @ 70°F)		0.10		0.12		0.22		
Condensate Connection Size (FPT)		3/4						
Air Coil Face Area (Sq. Ft.)		1.16			2.38		2.33	
Filter Size, Standard 1" deep (inches) (W x H)		20" x 10"			25" x 16"		24" x 16"	
Operating Weight (Lbs.)		99		103	142	150	182	
Shipping Weight (Lbs.)		123	123	128	168	176	209	
Overall Cabinet Dimensions (W x D x H)		19 x 34 x 11.5			19 x 42 x 17		19 x 43 x 17.3	
Packaging + Pallet Weight (Lbs.)		28.47						
Waterside Economizer Section (Lbs.)		22			33	41		
Waterside Economizer Coil Volume (Gal.)		.24			.55	.62		
Hot Gas Reheat (HGRH) Adder (Lbs.)		N/A			3.93	6.26		

Table 23: Unit sizes 036 through 070

Description		Unit Size				
		036	042	048	060	070
Compressor Type		Scroll				
Refrigeration Charge (Oz.)	Single Stage	50	48	54	60	69
	Two Stage	49	48	51	59	69
HGRH Refrigeration Charge Adder (Oz.)		19		20		26
Fan Wheel (D x W)		9" x 7"	10" x 8"		11" x 10"	
PSC Fan Motor HP		1/3	1/2		3/4	
EC Constant Torque Motor HP		1/2		3/4	1	
EC Constant CFM Motor HP		1/2	3/4		1	
Water Connection Size (FPT)		3/4"		1"		
Coax Volume (Gal. @ 70°F)		0.43		0.48	0.82	
Condensate Connection Size (FPT)		3/4				
Air Coil Face Area (Sq. Ft.)		3.34		4.09		5.54
Filter Size, Standard 1" deep (inches) (W x H)		30" x 18"		16" x 20" (Qty 2)		22" x 20" (Qty 2)
Operating Weight		218	236	296	313	332
Shipping Weight		255	273	331	345	379
Overall Cabinet Dimensions (W x D x H)		21.5 x 49 x 19		24 x 54 x 21		24 x 65 x 21
Packaging + Pallet Weight (Lbs.)		28.47		34.7		
Waterside Economizer Section (Lbs.)		50		53	60	
Waterside Economizer Coil Volume (Gal.)		.82		1.15	1.1	
Hot Gas Reheat (HGRH) Adder (Lbs.)		7.41		10.08		12.46

GCH Unit, Left and Right Hand, End and Straight Discharge – 007-036

Cabinet Dimensions, Pipe Connections, Condensate Drain, Electrical Locations

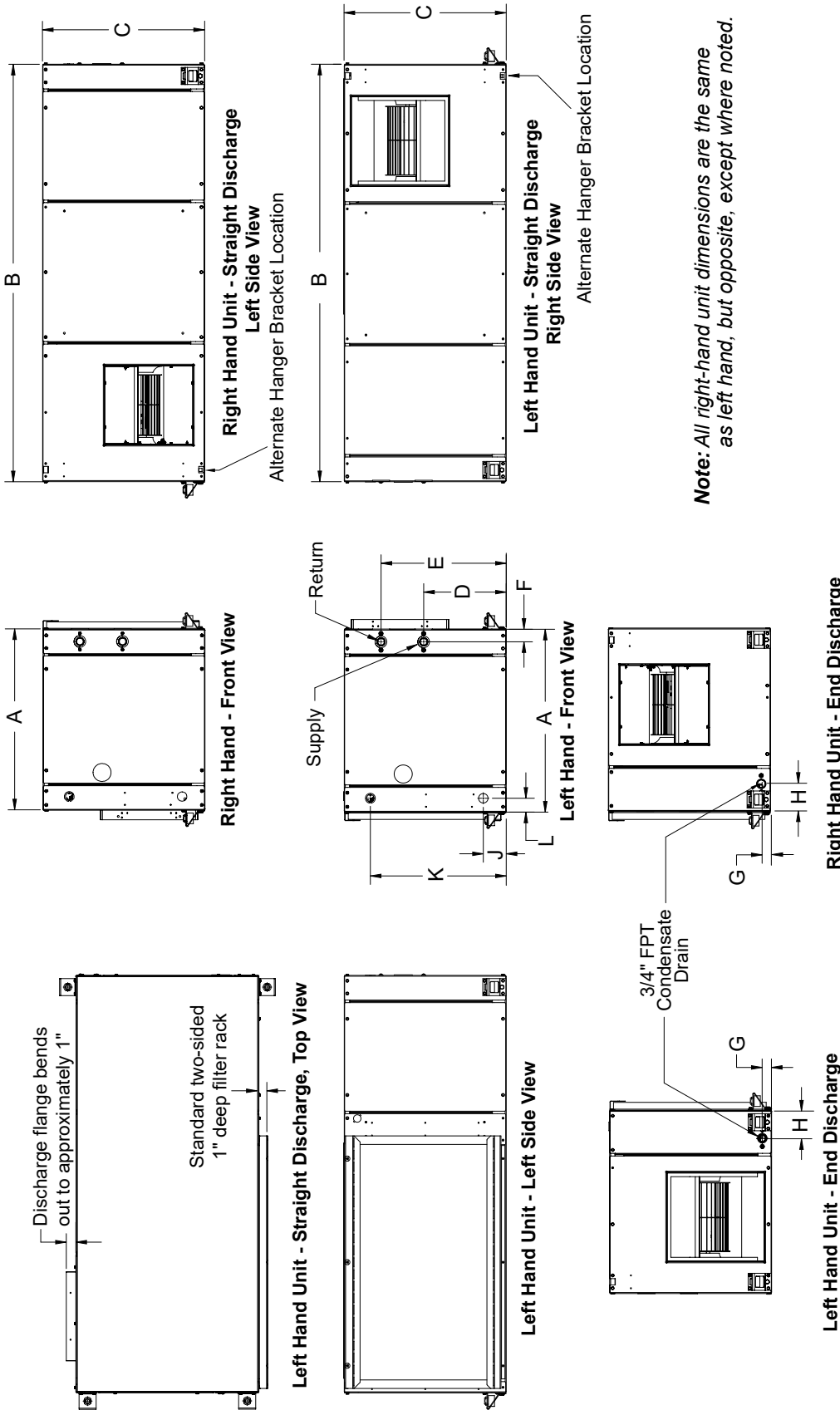

Table 24: GCH unit, left and right hand, end and straight discharge - 007-036

Unit Size	Overall Cabinet Dimensions (in inches)			Pipe Connections (in inches)				3/4" FPT Condensate Drain				Electrical Entry Locations		
	A = Width	B = Depth	C = Height	Connection Size (FPT)	D	E	F	G	H	J (Line Voltage)	K (Low Voltage)	L		
007, 009	18.9	33.9	11.5	0.5	1.6	10.3	2.4	0.9	3.3	2.7	10.4	1.6		
012	18.9	33.9	11.5	0.5	1.2	9.7	1.2	0.9	3.3	2.7	10.4	1.6		
015, 019	18.9	41.9	17.0	0.5	7.9	11.4	1.5	1.4	3.3	2.7	15.7	1.6		
024, 030	19.9	42.9	17.3	0.75	7.1	11.2	1.5	1.4	3.3	2.7	15.9	1.6		
036	21.4	48.9	19.0	0.75	9.7	14.6	1.5	1.4	3.3	2.7	15.9	1.6		

GCH Unit, Left and Right Hand, End and Straight Discharge - 042-070

Cabinet Dimensions, Pipe Connections, Condensate Drain, Electrical Locations

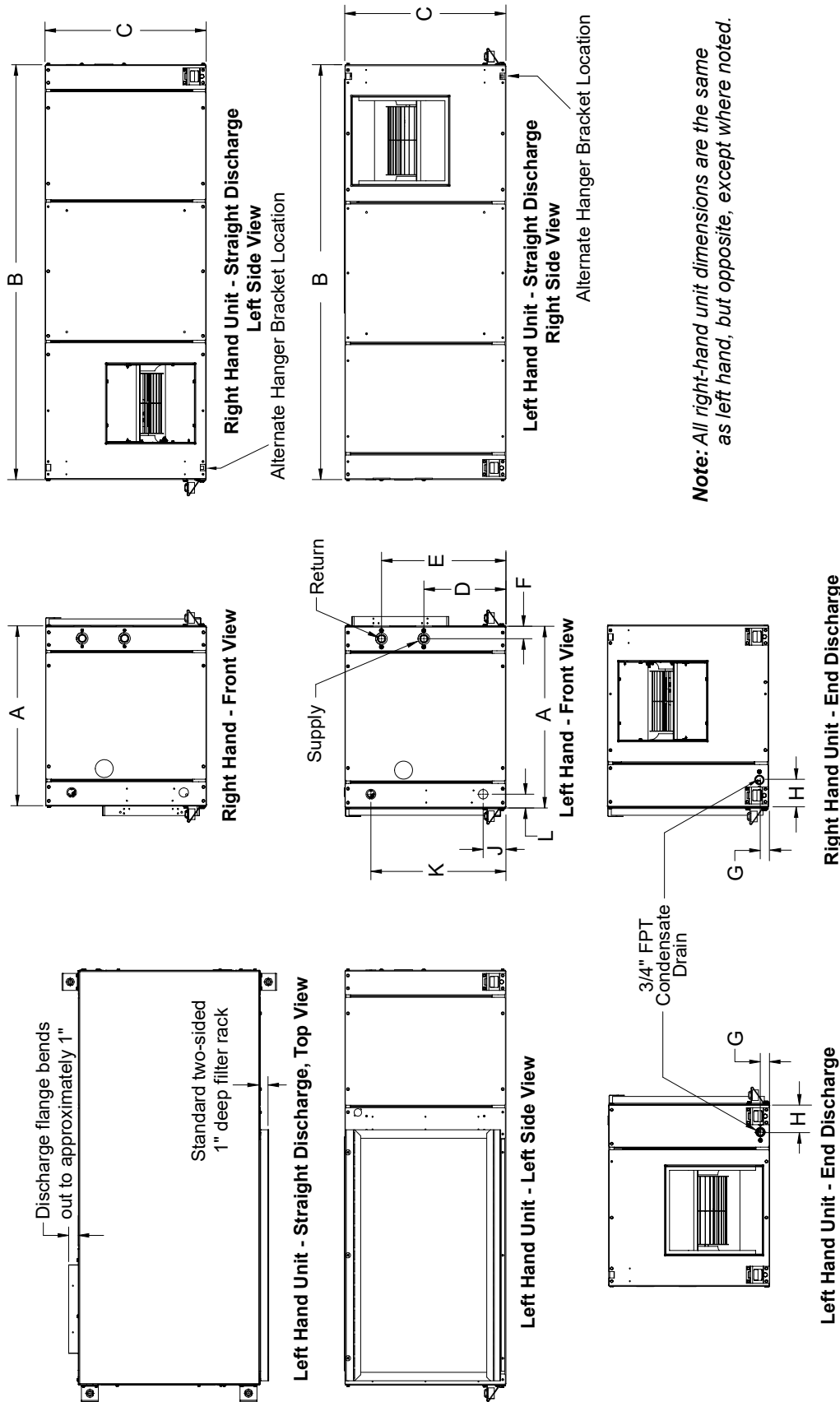

Table 25: GCH unit, left and right hand, end and straight discharge - 042-070

Unit Size	Overall Cabinet Dimensions (in inches)			Pipe Connections (in inches)				3/4" FPT Condensate Drain				Electrical Entry Locations		
	A = Width	B = Depth	C = Height	Connection Size (FPT)	D	E	F	Supply	Return	G	H	J (Line Voltage)	K (Low Voltage)	L
042	21.4	48.9	19.0	0.75	9.7	14.6	1.5	1.5	1.5	1.1	3.3	2.7	15.9	1.6
048	23.9	53.9	21.0	1.0	10.8	14.6	1.5	1.5	1.5	1.4	3.3	2.7	17.7	1.6
060	23.9	53.9	21.0	1.0	10.8	14.6	1.5	1.5	1.5	1.4	3.3	2.7	17.7	1.6
070	23.9	64.9	21.0	1.0	10.8	16.1	1.5	1.5	1.4	1.4	3.3	2.7	17.7	1.6

GCH Unit, Left and Right Hand, End and Straight Discharge - 007-036

Discharge Opening, Filter Rack Dimensions, Hanger Brackets Locations

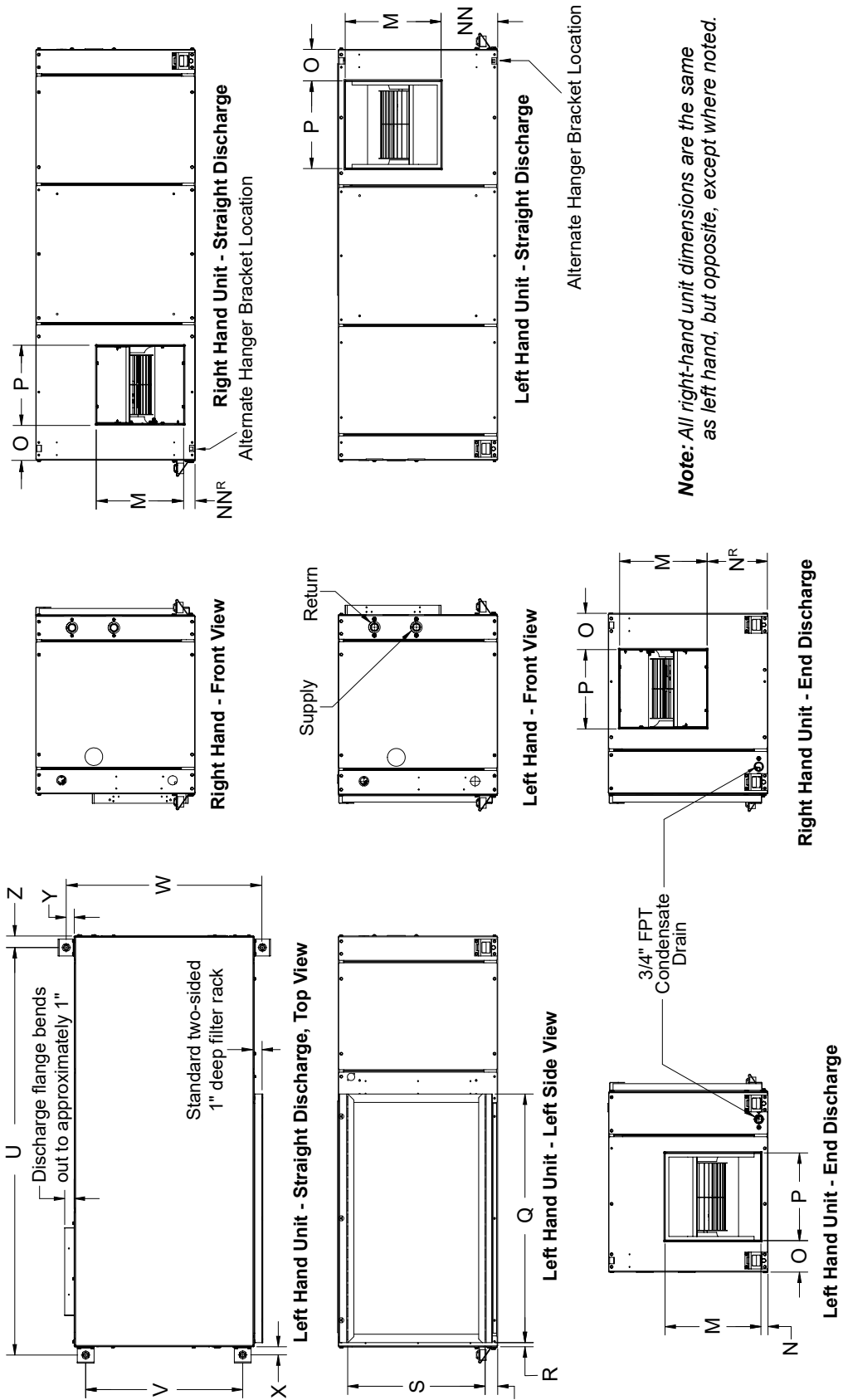

Table 26: GCH unit, left and right hand, end and straight discharge - 007-036

Unit Size	*Discharge Opening (in inches)										Standard Filter Rails Location (in inches)					Hanger Bracket Locations				
	M	N	N ^R	NN	NN ^R	O	P	Q	R	S	T	U	V	W	X	Y	Z			
007, 009, 012	4.9	5.3	1.3	1.3	5.3	3.0	9.4	18.4	0.5	10.3	1.0	33.6	16.8	20.9	1.0	1.0	1.1			
015, 019	10.4	1.1	5.7	5.7	1.1	3.0	9.3	24.9	0.5	16.3	1.6	41.6	16.2	20.9	1.0	1.0	1.4			
024, 030	10.4	1.2	5.8	5.8	1.2	3.4	9.3	23.9	0.5	16.3	1.0	42.6	17.2	21.9	1.0	1.0	1.4			
036	10.4	1.4	7.3	7.3	1.4	4.4	9.3	29.6	0.5	18.3	0.6	48.6	18.7	23.4	1.0	1.0	1.4			

* Discharge opening dimensions are to the outside edge of flanges bent out to 90 degrees at perforations. Dimensions are approximate and dependent on degree of bend.

GCH Unit, Left and Right Hand, End and Straight Discharge - 042-070

Discharge Opening, Filter Rack Dimensions, Hanger Brackets Locations

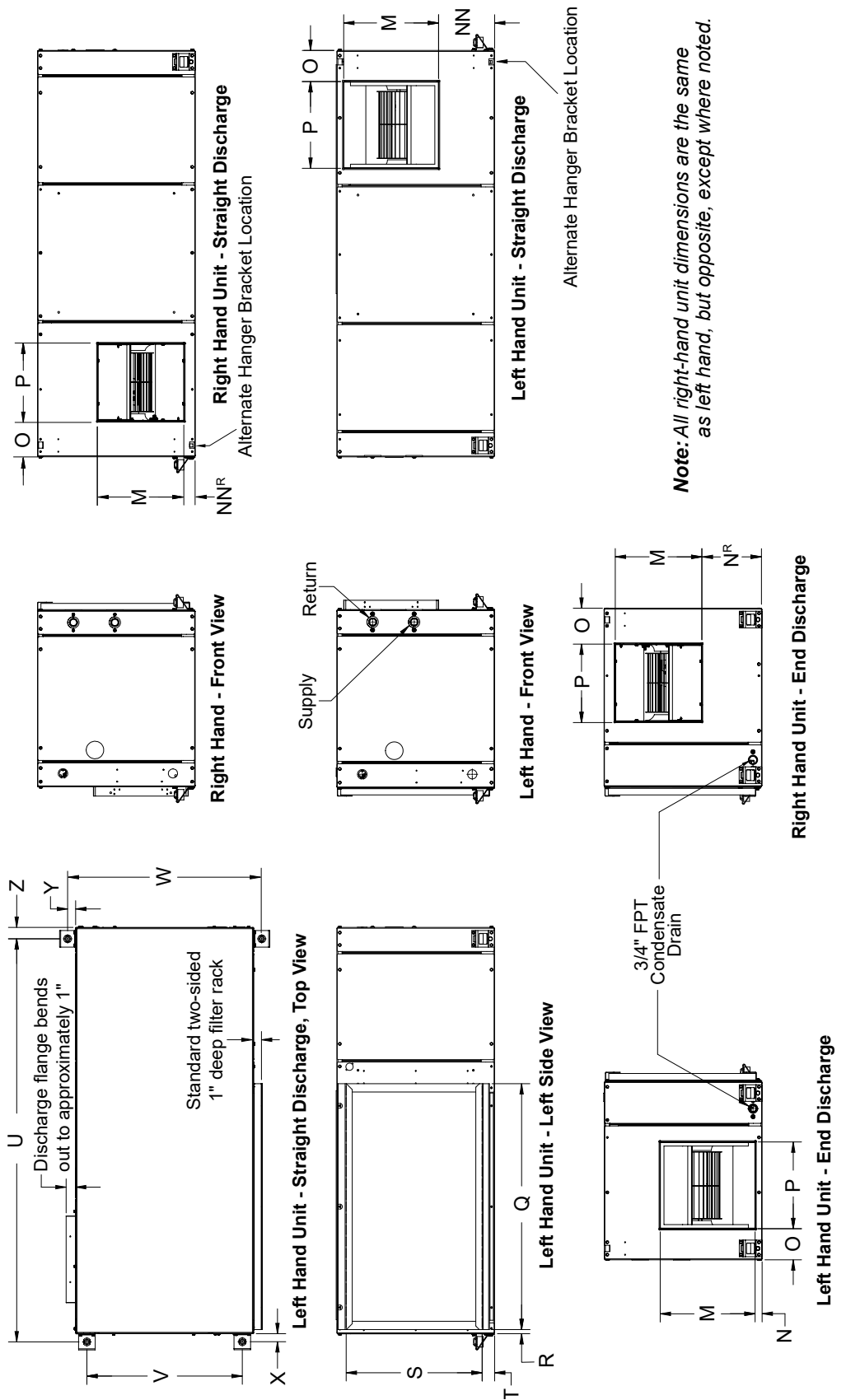

Table 27: GCH unit, left and right hand, end and straight discharge - 042-070

Unit Size	*Discharge Opening (in inches)										Standard Filter Rails Location (in inches)					Hanger Bracket Locations				
	M	N	N ^R	NN	NN ^R	O	P	Q	R	S	T	U	V	W	X	Y	Z			
042	11.4	0.8	6.7	6.7	0.8	3.8	10.4	29.6	0.5	18.3	0.6	48.6	18.7	23.4	1.0	1.0	1.4			
048	11.4	3.0	6.7	6.7	3.0	5.3	10.4	32.2	1.3	20.3	0.6	53.6	21.2	25.9	1.0	1.0	1.4			
060	13.6	2.4	5.0	5.0	2.4	4.5	13.1	32.2	1.3	20.3	0.6	53.6	21.2	25.9	1.0	1.0	1.4			
070	13.6	2.4	5.0	5.0	2.4	6.4	13.1	44.3	0.5	20.3	0.6	64.6	21.2	25.9	1.0	1.0	1.4			

* Discharge opening dimensions are to the outside edge of flanges bent out to 90 degrees at perforations. Dimensions are approximate and dependent on degree of bend.

Optional Filter Racks Dimensions

Figure 9: Optional filter racks dimensions (left hand unit shown)

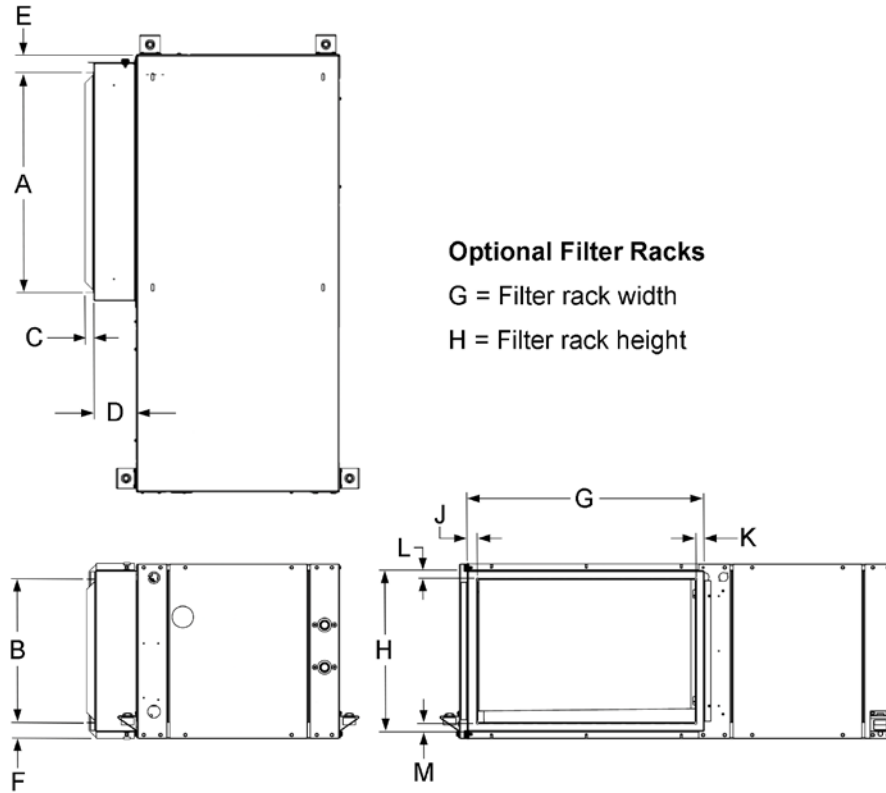

Table 28: Optional filter racks letter dimensions for Figure 9

Unit Size	*A	*B	C	D		E	F	G	H	*J	*K	*L	*M
				2-inch	4-inch								
007, 009, 012	16.2	8.5	0.9	2.2	4.2	1.7	1.5	17.9	10.0	1.0	0.8	0.8	0.8
015, 019	22.2	14.1	0.9	2.2	4.2	1.7	1.5	23.9	15.6	1.0	0.8	0.8	0.8
024, 030	21.7	14.4	0.9	2.2	4.2	1.7	1.5	23.4	15.9	1.0	0.8	0.8	0.8
036	27.2	16.1	0.9	2.2	4.2	1.7	1.5	28.9	17.6	1.0	0.8	0.8	0.8
042	27.2	16.1	0.9	2.2	4.2	1.7	1.5	28.9	17.6	1.0	0.8	0.8	0.8
048	31.4	18.1	0.9	2.2	4.2	1.7	1.5	33.2	19.6	1.0	0.8	0.8	0.8
060	31.4	18.1	0.9	2.2	4.2	1.7	1.5	33.2	19.6	1.0	0.8	0.8	0.8
070	44.3	18.1	0.9	2.2	4.2	1.7	1.5	45.7	19.6	1.0	0.8	0.8	0.8

Notes: *Filter rack flange dimensions are to the outside edge of the flange when bent out to 90 degrees at perforations. Dimensions are approximate and dependent on degree of bend.

Optional Disconnect Switch Location Dimensions

Figure 10: Optional disconnect switch location dimensions (right hand unit shown)

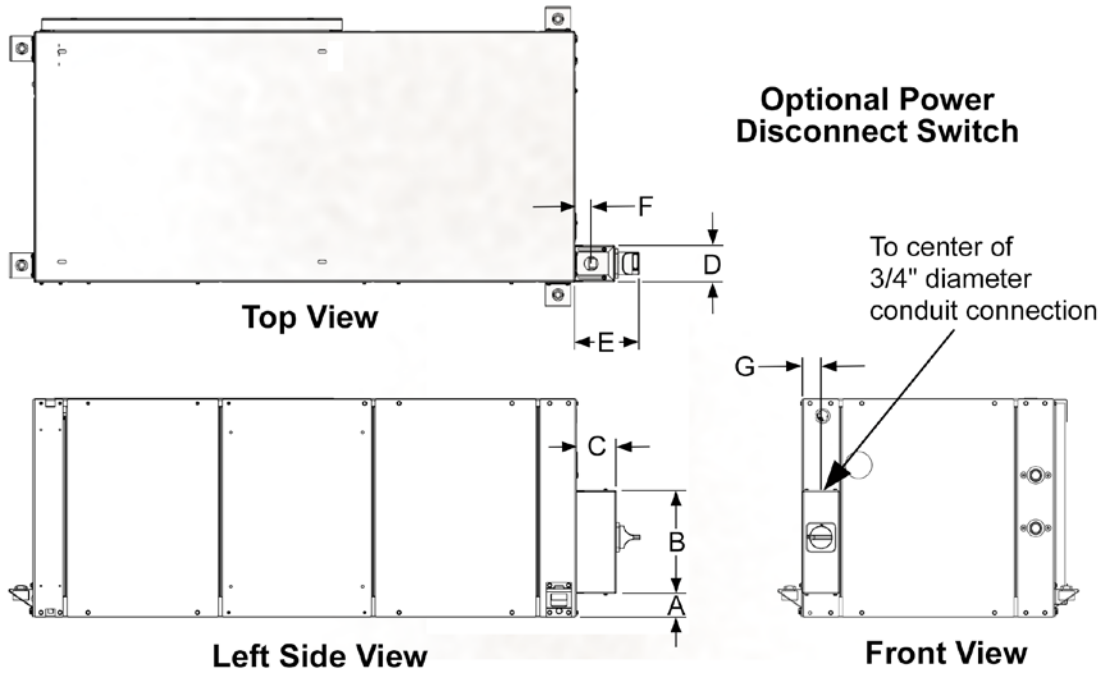

Table 29: Letter dimensions for Figure 10

Unit Size	A	B	C	D	E	F	G
007, 009, 012	1.7	8.1	3.1	2.9	5.1	1.3	1.5
015, 019	1.9	8.1	3.1	2.9	5.1	1.3	1.5
024, 030	1.9	8.1	3.1	2.9	5.1	1.3	1.5
036	1.9	8.1	3.1	2.9	5.1	1.3	1.5
042	1.9	8.1	3.1	2.9	5.1	1.3	1.5
048	1.9	8.1	3.1	2.9	5.1	1.3	1.5
060	1.9	8.1	3.1	2.9	5.1	1.3	1.5
070	1.9	8.1	3.1	2.9	5.1	1.3	1.5

Model GCH Unit With Waterside Economizer Dimensions

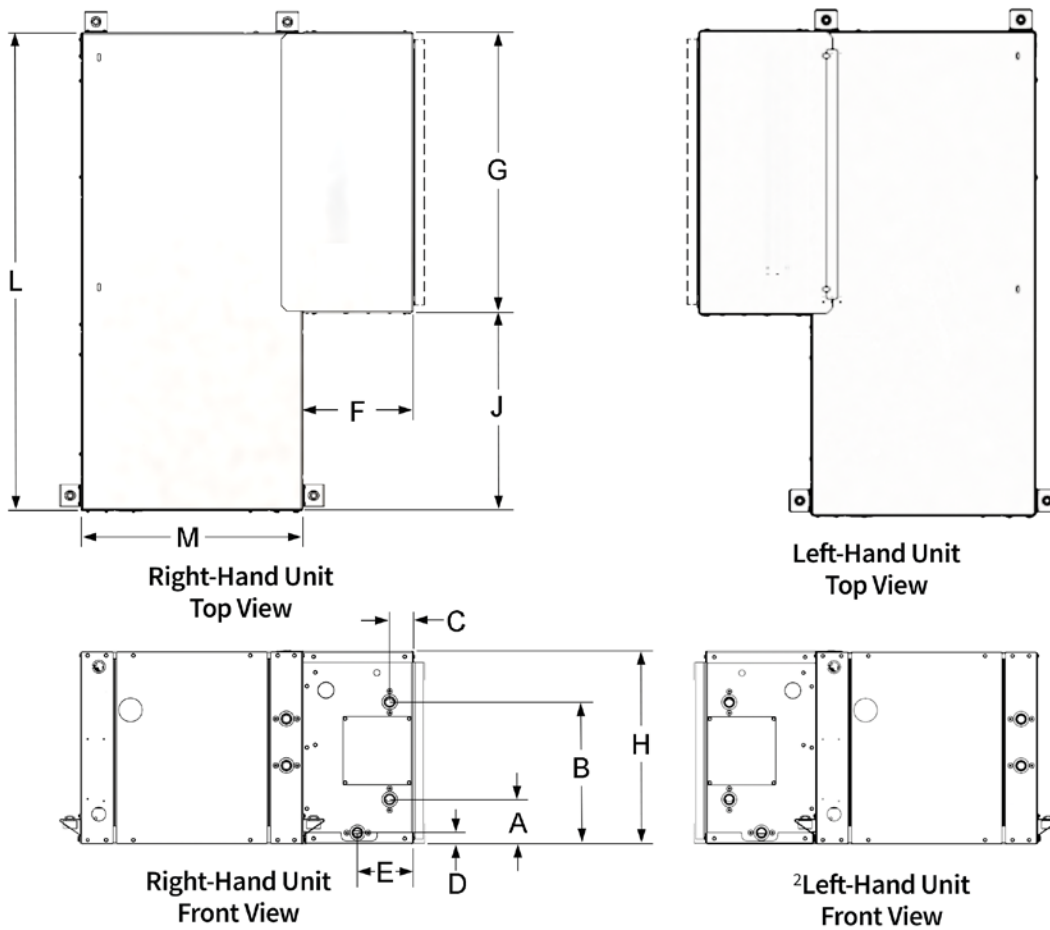

Table 30: Model GCH unit with waterside economizer - dimensions

Unit Size	Supply & Return Connections			3/4" FPT Condensate Drain		Waterside Economizer Overall Cabinet Section			J	L	M	
	Connection Size (FPT)	A (Supply)	B (Return)	C	D	E	F	G				H
007, 009, 012	0.75	2.8	9.7	2.6	1.0	5.0	9.9	19.4	11.6	14.7	33.9	18.9
015, 019	0.75	4.0	12.5	2.1	1.0	5.0	9.9	25.6	17.1	16.4	42.0	18.9
024, 030	0.75	4.0	12.8	2.1	1.0	5.0	9.9	25.1	17.4	17.8	43.0	19.9
036, 042	0.75	3.5	13.5	2.1	1.0	5.0	9.9	30.6	19.1	18.4	49.0	21.4
048, 060	0.75	3.5	15.5	1.4	1.0	4.5	9.9	34.9	21.1	19.1	53.9	23.9
070	0.75	3.5	15.5	2.3	1.0	5.0	9.9	46.5	21.1	18.5	65.0	23.9

Notes: 1. All dimensions within ± 0.10 inches (2.5 mm).
 2. Left-hand waterside economizer connections same as right-hand but opposite.

General

Units shall be supplied completely factory assembled, piped, internally wired, fully charged with R-410A, horizontal unit and capable of operating over an entering water temperature range from 55°F to 110°F on water loop (boiler/tower) models, and 20° to 110°F on ground loop (geothermal) models. All equipment must be AHRI rated and certified in accordance with Standard 920 and must be tested, investigated, and determined to comply with the requirements of the standards for Heating and Cooling Equipment UL-60335-2-40 Version 2 for the US and CAN/CSA-C22.2 NO. 60335-2-40 Version 2 for Canada. Each unit shall be ETL and ETLC Listed. Each unit shall be run tested at the factory. The installing contractor shall be responsible for furnishing and installing Water Source Heat Pumps as indicated on the plans and per installation instructions.

All water loop (boiler/tower) units shall include a:

- Low refrigerant suction line temperature safety device (freeze protection)

All ground loop (geothermal) units shall have:

- Insulated water-to-refrigerant heat exchanger
- Insulated water and refrigerant piping, designed to prevent sweating
- Low refrigerant suction line temperature safety device (freeze protection)

Electrical

The control box shall be located within the unit and shall contain controls for compressor, reversing valve and fan motor operation and shall have either a factory-installed 50VA or a selectable 75VA transformer (for added electrical capacity). Unit shall be name-plated to accept time delay fuses or HACR circuit breaker for branch over-current protection of the power source. Unit control system shall provide heating or cooling as required by the set points of the wall thermostat or sensor. The unit control scheme shall provide for fan operation simultaneous with compressor operation (fan interlock) regardless of the thermostat type. The unit shall be capable of providing an output signal to an LED on the thermostat or sensor to indicate a "fault" condition from the activation of any one of the safety devices.

Casing and Cabinet

Unit cabinet shall be fabricated from heavy gauge G-60 galvanized sheet metal. Interior surfaces shall be lined with ½-inch, 1½ lb. dual density coated fiberglass insulation. All insulation shall have edges sealed or tucked in order to prevent introduction of fibers into the discharge air. Standard cabinet insulation must meet NFPA 90A/90B requirements, air erosion and mold growth limits of UL-181, fungi resistance per ASTM G21 or

ASTM C 1338, and bacterial resistance per ASTM G22. All insulation shall have a flame spread of less than 25 and a smoke developed classification of less than 50 per ASTM E-84 and UL 723.

Cabinets shall have separate openings and knockouts for entrance of line voltage and low voltage control wiring. Supply and return water connections shall be FPT fittings and shall be securely mounted flush to the cabinet corner post allowing for connection to a flexible hose without the use of a back-up wrench.

Three access panels, two for the compressor compartment and one for the blower compartment. Unit shall have an insulated panel separating the blower compartment from the compressor compartment.

Units shall have a ¾" fold-out discharge duct collar for connection of supply air ductwork.

Unit Insulation Option

- Indoor Air Quality (IAQ) closed cell foam on entire unit; replaces standard fiberglass

Sound Attenuation Options

■ Sound Blanket

- For additional sound attenuation on unit sizes 024 - 070, a compressor blanket constructed from high performance Duracoustic sound material with superior sound absorption and deadening properties shall be provided. The sound rated material has a density of 1.5 lb./ft³ and is made from a loaded vinyl reinforced barrier and is embedded with 0.5" urethane foam

■ Sound Package

- 1-inch dual layer insulation on entire unit (Unit Sizes 007 - 019)
- 1-inch dual layer insulation in air handling section (Unit Sizes 024 - 070), 1/2-inch dual-density fiberglass insulation in the compressor section and compressor sound blanket (Unit Sizes 024 - 070)

Filter Rack and Filters

Units shall have factory-installed, one inch thick filter rails on the top and bottom for filter support with 1" inch thick disposable standard filter(s) and ¾" inch fold-out duct collar for connection of return air ductwork.

Filter Options

■ Factory-installed 2-inch thick MERV 8 filter

- Factory-installed in a low leakage 2-inch, 4-sided combination filter rack with ¾" return air duct collar and removable, tool-less access door with thumb screws. Gasketing shall prevent air leakage between the filter rack and unit casing

- **Factory-installed 4-inch thick MERV 13 filter**
 - Factory-installed in a low leakage 4-inch, 4-sided combination filter rack with ¾" return air duct collar and removable, tool-less access door with thumb screws. Gasketing shall prevent air leakage between the filter rack and unit casing

Supply and return, condenser water connections

Shall be FPT fittings, brazed copper water tubes and securely flush mounted to the cabinet corner post allowing for connection to a flexible hose without the use of a back-up wrench.

Drain Pan

The condensate pan shall be constructed of high density polypropylene to prevent corrosion and sweating. The bottom of the drain pan shall be sloped on two planes to provide complete drainage of water from the pan to meet IAQ requirements. The water source heat pump unit as standard shall be supplied with electronic condensate overflow protection. A mechanical float switch will not be accepted.

Optional Stainless Steel Drain Pan

Unit shall utilize a corrosion resistant, stainless steel, insulated drain pan. Drain pan connection shall be ¾" FPT flush threaded fitting. The drain pan shall be designed to ensure no pooling of condensate water per ASHRAE 62.2.

Refrigerant Circuit

Units shall have a R-410A sealed refrigerant circuit, which includes a rotary or scroll compressor, thermostatic expansion valve, an aluminum lanced-fin and rifled copper tube refrigerant-to-air heat exchanger, reversing valve, and coaxial, tube-in-tube, refrigerant-to-water heat exchanger. The airside coil shall be rated at 600 psig working pressure. The coaxial coil shall be made of a copper inner tube and a painted steel outer tube and be rated at 500 psig working pressure on the waterside and 600 psig working pressure on the refrigerant side. The compressor shall have thermal overload protection.

The compressor shall have a dual level vibration isolation system. The compressor will be mounted on vibration isolation grommets to a heavy gauge compressor mounting plate, which is then isolated from the cabinet base to minimize vibration transfer.

Safety controls shall include a minimum of 3 safety devices; high refrigerant pressure switch, low refrigerant pressure switch and a low refrigerant suction temperature sensor. The low refrigerant suction temperature sensor shall provide freeze protection for the water coil and the air coil. Refrigerant gauge access fittings shall be factory installed on high and low pressure refrigerant lines to facilitate field service. Activation of any safety device shall prevent the compressor from operating via a microprocessor lockout circuit. The lockout circuit shall be reset at the thermostat or at the unit disconnect switch.

- **Cupro-Nickel coil option:** The coaxial coil shall be made of cupro-nickel inner tube and a painted steel outer tube
- **Coated air coil option:** All air coils shall be coated with an optional inorganic, silicon-based nano-ceramic coating that must pass a ASTM B-117 3,000 hour salt spray test to provide protection against corrosion due to acids, solvents, and salt found in the environment

Fan and Motor Assembly

Unit shall have a direct drive centrifugal fan motor assembly. The fan housing shall have a removable orifice ring to facilitate fan motor and fan wheel removal. The fan motor shall be 3-speed, permanently lubricated, PSC type, with internal thermal overload protection.

Optional Fan Motors

- **Constant Torque motor (sizes 007-012)**
 - The fan motor shall be permanently lubricated, constant torque electronically commutated for improved operation. Field adjustable CFM settings shall be accomplished from a 4-position switch in the control box
- **Constant Torque motor (sizes 015-070)**
 - The fan motor shall be permanently lubricated, constant torque electronically commutated for improved operation. These motors shall feature 5 pre-programmed torque settings that can be changed in the field to match design airflow requirements
- **Constant CFM motor (unit sizes 015-070)**
 - The fan motor shall be permanently lubricated, variable speed, constant CFM, electronically commutated for improved operation. Field adjustable CFM settings shall be accomplished from a 4-position switch in the control box. The constant CFM EC motor shall have the ability to reduce the CFM as the space temperature approaches the thermostat setpoint for improved dehumidification. Units with 460/60/3 power require the 4th wire neutral

Hot Gas Reheat Smart Dehumidification Option

The optional factory-installed hot gas reheat coil shall be used as part of a dehumidification operating sequence. Hot gas reheat shall be enabled when the space humidity level is above a user selectable set point. Superheated refrigerant gas shall be diverted to the reheat coil and unit fan shall operate at dehumidification fan speed upon a call for dehumidification. This option includes an aluminum microchannel hot gas reheat coil and a solenoid actuated 3-way valve. A corrosion resistant coated hot gas reheat coil shall be available as an option.

Waterside Economizer

A factory mounted and wired waterside economizer shall consist of a hydronic cooling coil located between the unit filter rack and evaporator, a 2-position 3-way diverting valve, a manual air vent, and an entering fluid sensor. The cabinet shall be fabricated from heavy gauge G-60 galvanized sheet metal with the top and bottom interior surfaces lined with a minimum 3/8-inch thick closed-cell non-fibrous IAQ insulation and 1/8-inch thick closed-cell non fibrous insulation on the interior side walls. Components shall be accessible without removing economizer. An insulated stainless steel drain pan compliant with ASHRAE 62.1 including electronic condensate overflow protection shall be provided. Economizer flush mounted piping connections shall be on the same side as the WSHP unit piping connections. For corrosive environment applications, a corrosion resistant coated coil shall be available. The unit mounted control system shall allow economizer operation for either supplemental to mechanical unit cooling or independent, based on entering fluid temperature. Economizer operation shall be permitted when entering fluid temperature is below the adjustable range from 50°F to 70°F. Default setting is 55°F. Economizer operation shall be initiated from a multi-stage remote thermostat or sensor. Economizer operation will be permitted with entering fluid temperature down to 35°F.

Microprocessor-Based Control System

MicroTech SmartSource Control System - Unit shall have a microprocessor- based control system. The unit control logic shall provide cooling, heating, smart dehumidification, and/or economizer operation as required by the thermostat and/or sensor. The control system shall provide the following for stand-alone operation:

1. The use of standard non-programmable or programmable wall thermostats.
2. Fan operation simultaneous with the compressor (fan interlock) regardless of thermostat logic.
3. Time delay compressor operation.
4. Compressor short cycle protection of a minimum of three minutes before restart is possible.
5. Random unit start-up
6. Single grounded wire connection for activation of the unoccupied or unit shutdown modes.
7. Night setback temperature setpoint input signal from the wall thermostat.
8. Override signal from wall thermostat to override unoccupied mode for 2 hours.
9. Brownout protection to suspend unit operation if the supply voltage drops below 80% of normal.
10. Condensate overflow protection to suspend cooling operation in an event of a full drain pan.
11. Suspended compressor operation upon activation of the high refrigerant pressure switch.
12. Suspended compressor operation upon activation of the low refrigerant pressure switch.
13. Suspended compressor operation upon activation of the low refrigerant suction temperature switch.
14. Cooling operation activated for 60 seconds upon activation of the low suction temperature sensor – defrost cycle.
15. Method of defeating compressor, reversing valve and fan time delays for fast service diagnostics.
16. Remote Alarm reset - Provides ability to remotely reset the unit upon a fault condition.
17. Intelligent Reset attempts to clear faults the first two times they occur within a 24-hour period and locks-out compressor operation upon the third fault.
18. Control shall be configurable to accommodate thermostat or sensor based control.
19. Unit mounted LED annunciators aid in diagnosing unit operation by indicating the water source heat pump operating mode and alarm conditions.
20. Freeze fault protection (option): Unit shall be equipped with an additional sensor located on the leaving water piping to be used to help protect the unit from excessively low water coil and air coil temperatures.
21. Electric heat control output (option): Unit shall be equipped with a 24-volt control signal to activate a field-installed electric heater.

MicroTech® III Control with LONWORKS communication module – Unit shall have a microprocessor-based control system. The unit control logic shall communicate over a LONMARK communications network. The unit controller is factory programmed [LONMARK® 3.4 certified Application Code the current standard for new applications] and tested with all the logic required to monitor and control heating and cooling operation. The controller sets the unit mode of operation, monitors water and air temperatures, and can communicate fault conditions via a LONMARK communications network. Units with the MicroTech and LONWORKS communication module include return air, discharge air and leaving water temperature sensors. Space temperature sensor options include a set-point adjustment, tenant override button, and the capability of substituting the return air sensor with a wall-mounted room sensor.

MicroTech SmartSource Control with BACnet Communication module – Unit shall have a microprocessor-based control system. The unit control logic shall communicate over a BACnet communications network. The BACnet communication module shall incorporate an Atmel ARM7 Thumb series MCU and be capable of supporting a full MSTP BACnet implementation. The microprocessor shall also support SPI compatible communications with the MCU of the MicroTech Smart-Source controller. The physical interface to a BACnet BAS network shall be through an industry standard RS-485 transceiver capable of existing on an RS-485 network of up to 64 nodes. The unit controller is factory programmed and tested with all the logic required to monitor and control heating and cooling operation. The controller sets the unit mode of operation, monitors water and air temperatures, and can communicate fault conditions via a BACnet communications network. Units outfitted with MicroTech and BACnet Communication modules include return air, discharge air and leaving water temperature sensors. Space temperature sensor options include a set-point adjustment, tenant override button, and the capability of substituting the return air sensor with a wall-mounted room temperature sensor.

Each communicating unit controller performs the following unit operations:

- Enable heating and cooling to maintain space temperature set point at the room sensor
- Enable fan and compressor operation
- Monitor all safety controls (see Safety Controls)
- Monitor discharge and return air temperature
- Monitor leaving water temperature
- Relay status of all vital unit functions
- Support optional control outputs

If there are no current alarm conditions, a green LED on the annunciator board will indicate occupied unit operating mode. If an alarm condition exists, the MicroTech Smart-Source unit controller will send the fault condition to the LED annunciator, which will assist in troubleshooting the unit. Heat pumps with the MicroTech SmartSource unit controller with a LONWORKS Communication Module is designed to be linked with a centralized Building Automation System (BAS) through a LONMARK communications network for centralized scheduling and management of multiple heat pumps. Wall-mounted room sensors are available to control the operation of each MicroTech Water Source Heat Pump.

Safety Controls – Standard

Safety controls shall include as standard, a minimum of 3 safety devices. Activation of any safety device shall prevent the compressor from operating via a microprocessor lockout circuit. The lockout circuit shall be reset at the thermostat or at the unit disconnect switch.

- High pressure switch located in the refrigerant discharge line
- Low pressure switch located in the refrigerant suction line shall protect against loss of refrigerant charge
- Low suction temperature sensor, located in the compressor suction line shall protect the water coil and the air coil against freeze-up

Refrigerant gauge access fittings shall be factory installed on high and low pressure refrigerant lines to facilitate field service.

- Condensate overflow protection sensor shall be factory installed in the drain pan of the unit

Safety Controls – Optional

Unit shall be equipped with an additional sensor located on the leaving water piping and used to help protect the unit from excessively low water coil and air coil temperatures.

Water Pressure Differential Switch

The optional, factory-mounted pressure differential switch monitors the water pressure drop across the heat exchanger and shall disable compressor operation if flow is not detected. Selectable as a factory installed option internal to the cabinet.

Non-Fused Disconnect Switch

This factory installed option shall include the addition of a 3-pole switch mounted on the unit. The switch shall have a lockout/tag out feature. The switch shall be rated to handle all the voltages available for the unit.

Warranty

Standard Warranty

- The standard unit warranty covers all parts for a period of 1 year after start-up, or 18 months after shipment; whichever occurs first

Optional Warranty

- An optional 1 or 4-year extended compressor warranty covers the compressor from the date at which the unit ships from the factory
- An optional 1 or 4-year extended refrigeration circuit warranty covers the entire refrigeration circuit and related components
- An optional 1 or 4-year extended complete unit warranty covers the entire unit and related components

Field Installed Accessories

Wall-Mounted Thermostats:

- Programmable Touch Screen Thermostat with optional humidity sensing
 1. Optional Remote Room Sensor
 2. Optional Outdoor Temperature Sensor
- Non-Programmable Thermostat
 1. Optional Remote Room Sensor
- Programmable Thermostat
 1. Optional Remote Room Sensor

Wall Mounted Room Temperature Sensors for BACnet and LonWORKS Communications:

- Digitally Adjustable Wall Sensor with Temperature and Humidity Display
- Adjustable Cool/Warm with Occupancy Switch, Override/Reset Button, Status LED, Fan and System Switch
- Adjustable 55°F to 95°F and 12°C to 33°C, Override/Reset Button, Status LED, Fan and System Switch
- Adjustable -5°F to +5°F and -21°C to -15°C, Override/Reset Button, Status LED, Fan and System Switch
- Basic Sensor, Override/Reset Button, Status LED

Hose Kits

Supply and Return Hose Kits

Two fire-rated flexible hoses with ASTM ratings of Flame Spread 25, Fuel Contribution 25 and Smoke Density 50 for connection to unit and field piping. Hoses shall be covered with stainless steel braiding to prevent damage. The automatic flow hose kit shall include an automatic flow control valve, two ball valves, two flexible hoses, a high flow Y-strainer, and may include a strainer blow-down and various other accessories. The automatic flow control valve shall be factory set to a rated flow, and shall automatically control the flow to within 10% of the rated value over a 40 to 1 differential pressure, operating range (2 to 80 PSID). Operational temperature shall be rated from fluid freezing, to 225°F. The valve body shall be constructed from hot forged brass UNS C37700 per ASTM B-283 latest revision. For details on hose kits refer to catalog 1196.

Jumper Hose Kit

(Used with Waterside Economizer)

The jumper hose kit used with waterside economizer shall include a single UL-94 VO fire rated hose with 1-inch male JIC x 90 degree male pipe plated steel adapter.

Condensate Hose Kits

- Optional plastic hose including fittings
- Optional fire-rated, braided steel hose including fittings

Motorized Valve and Ball Valve Kits

- Optional 2-way, Normally Open (N.O.) or Normally Closed (N.C.) motorized valves
- Optional 2-way, mechanical ball valve

Replacement Filters

2-inch MERV 8, 4 inch MERV 13, and 1-inch disposable filters shall be available as direct replacement to factory-installed filters.



Daikin Applied Training and Development

Now that you have made an investment in modern, efficient Daikin equipment, its care should be a high priority. For training information on all Daikin HVAC products, please visit us at www.DaikinApplied.com and click on Training, or call 540-248-9646 and ask for the Training Department.

Warranty

All Daikin equipment is sold pursuant to its standard terms and conditions of sale, including Limited Product Warranty. Consult your local Daikin Applied representative for warranty details. Refer to Form 933-430285Y. To find your local Daikin Applied representative, go to www.DaikinApplied.com.

Aftermarket Services

To find your local parts office, visit www.DaikinApplied.com or call 800-37PARTS (800-377-2787). To find your local service office, visit www.DaikinApplied.com or call 800-432-1342.

This document contains the most current product information as of this printing. For the most up-to-date product information, please go to www.DaikinApplied.com.

Products manufactured in an ISO Certified Facility.