

Navigator® Water-Cooled Screw Compressor Chillers

Model WWV
120 to 300 Tons (527 to 1055 kW)
HFC-134a Refrigerant
50/60 Hz



Introduction 3
Features and Benefits 4
Dimensions 6
Options and Accessories 8
Refrigeration Diagram 9
Application Consideration 10
Engineering Guide Specifications 13

Manufactured in an ISO 9001 & ISO 14001 certified facility



©2022 Daikin Applied. Illustrations and data cover the Daikin Applied product at the time of publication and we reserve the right to make changes in design and construction at any time without notice.

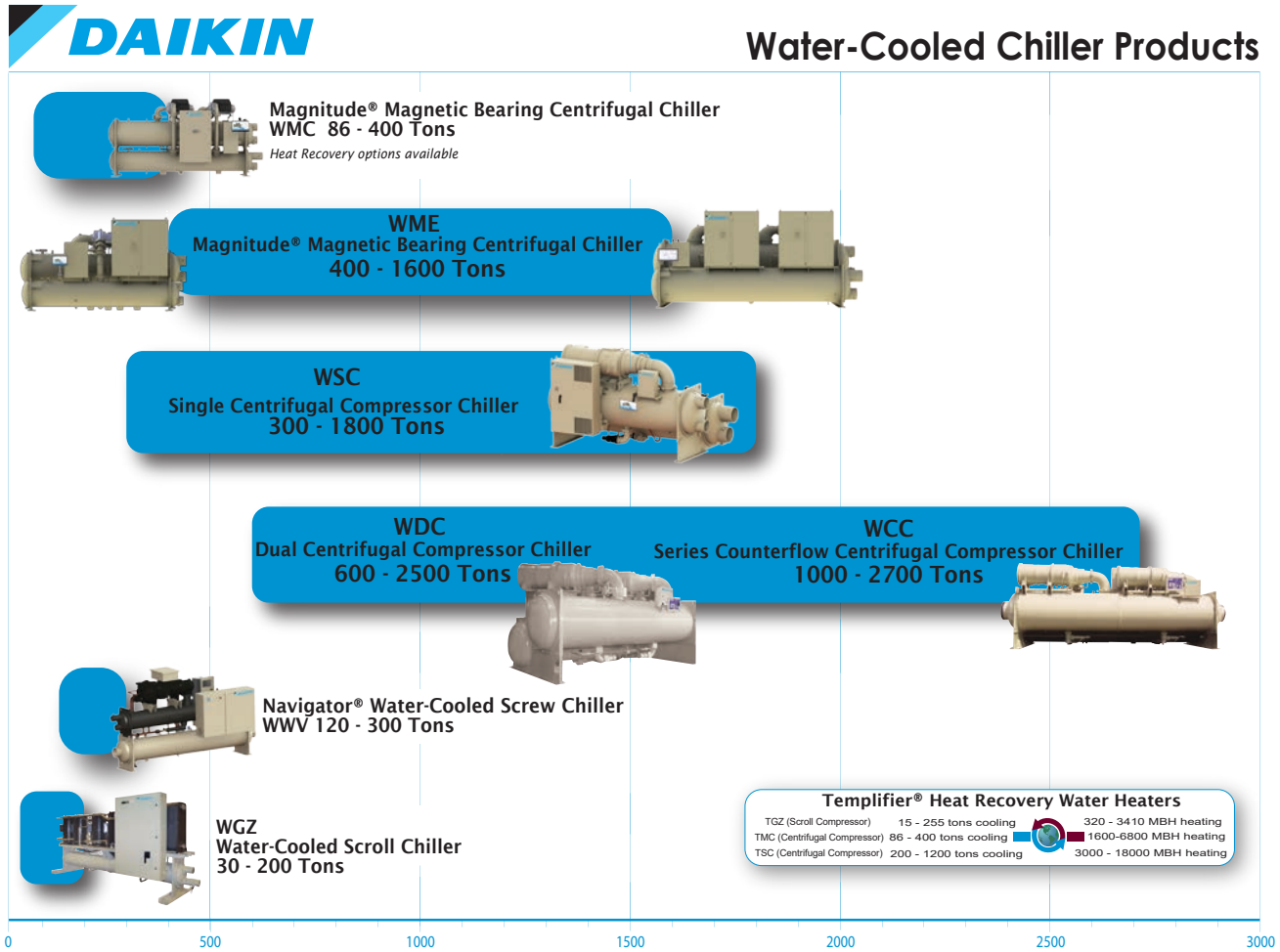

Technology That Just Makes Sense

The industry's next generation of screw compressor chillers is here today with Daikin Navigator® chillers. The new technology begins with variable volume ratio compressors, integral variable frequency drives, and direct drive technology. The high efficiency compressor is matched with highly efficient heat exchangers to make an impressive chiller. Model WWV chillers have many important features:

- State-of-the-art variable volume ratio (VVR®) compressor design optimizes efficiency at all operating conditions
- Integrated compressor variable frequency drive (VFD)
- User-friendly MicroTech® controls
- RapidRestore® and Fast Loading for mission critical applications
- Open Choices™ feature for BAS of your choice
- HFC-134a refrigerant (Zero ozone depletion)
- AHRI certification

Features and Benefits Summary

The Compressor Technology

- Unique compressor design with variable volume ratio capability and integrated VFD for exactly matching the specific required cooling at the best possible efficiency. The single rotor design leads to quiet operation at all load conditions.

The Control Technology

- Onboard digital electronics provide smart controls and include a user-friendly operator interface, RapidRestore® option, and Open Choices™ BAS flexibility.

Factory Testing

- Ensures trouble free startup and reliable operation.

Certifications and Standards

- Meets ASHRAE Std. 90.1, AHRI 550/590 certified, and contributes to LEED® certification.

Compressor Technology

The model WWV's exceptional efficiency and reliability is due to its cutting-edge compressor technology. Chiller performance is optimized at every condition and at every hour of the day with unique VVR® (variable volume ratio) compressor technology and patented high-efficiency oil separation. The compressor adjusts compression volumetric ratio to meet the demands of the building or process at that moment to maximize efficiency. While performance is matched in real-time as conditions vary, built-in and patented compressor mechanics reduce noise and vibration resulting in indoor-friendly sound levels at all load points.

Figure 1: VVR® Compressor Technology

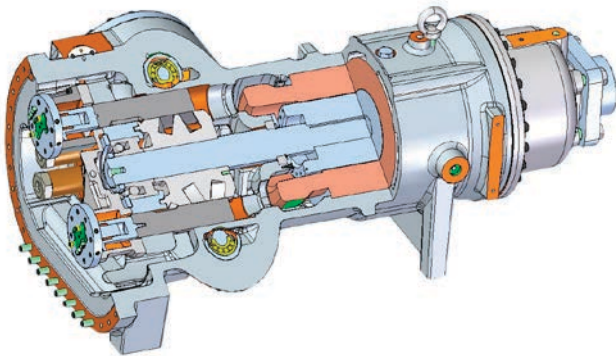

Integrated Variable Frequency Drive

A VFD modulates compressor speed in response to load and evaporator/condenser pressure. VFD's have the following benefits:

- Reduced annual energy costs when there are long periods of part load operation and/or low compressor lift (lower condenser water temperature)
- Reduced motor starting inrush current
- Reduced size of backup generators used to provide emergency power to chillers used on mission critical applications
- Increased power factor to reduce utility surcharges

Control Technology

It is only fitting that this revolutionary chiller design be matched with the advanced control technology to give you the ultimate chiller performance. The control design includes many unique energy-saving features and interface enhancements.

MicroTech® III Controller

The model WWV chiller utilizes MicroTech® III digital control electronics to proactively manage unit operation and provide communication to external chilled water and cooling tower pumps. The compressor runs at the minimum speed necessary to maintain cooling capacity and lift (which decreases with lower condenser water temperatures), thus minimizing energy usage over the entire range of operating conditions. By constantly monitoring chiller status and real time data, the MicroTech® III controller will automatically take proactive measures to relieve abnormal conditions or shut the unit down if a fault occurs.

Additional smart features that optimize operating efficiency have been incorporated into our MicroTech® III controls:

- Cooling tower control including on/off, staging, and VFD
- Direct control of water pumps
- Chilled water rest
- Demand limit control

RapidRestore®

Mission critical facilities such as data centers and hospitals are demanding stringent capabilities for chillers to restart and reach full load operation quickly in the event of a power loss. With the capability of RapidRestore®, model WWV chillers are engineered to meet those needs. See Table 1 for specifications.

RapidRestore® – Quickly restores cooling capacity when power is restored after a power failure

- **Compressor Start** – Amount of time required for the chiller to restart
- **Fast Loading** – Amount of time required for the chiller to reach a certain load condition

Table 1: WWV RapidRestore® Times- After Power Restoration

Compressor Start	Fast Loading to 100% Load
35 sec	160 sec*

* Estimated load time. Times may vary depending on operating conditions.

Open Choices™ BAS Flexibility

The exclusive Open Choices™ feature provides seamless integration and comprehensive monitoring, control, and two-way data exchange using industry standard protocols such as LonTalk®, BACnet® or Modbus®. Open Choices™ offers simple and inexpensive flexibility to use the Building Automation System (BAS) of your choice without an expensive gateway panel. Open Choices™ benefits include:

- Easy to integrate into your BAS of choice
- Factory- or field-installed communications module
- Integrated control logic for factory options
- Easy-to-use local user interface
- Comprehensive data exchange

Certifications and Standards

As with many other Daikin Applied chiller products, the WWV meets all necessary certifications and standards.

AHRI Certification

Part load performance can be presented in terms of Integrated Part Load Value (IPLV), which is defined by AHRI Standard 550/590. Based on AHRI Standard 550/590, and as shown in Figure 2, a typical chiller can operate up to 99% of the time at off-peak conditions and usually spends most of this time at less than 60% of design capacity.

Figure 2: IPLV Defined by AHRI Standard 550/590

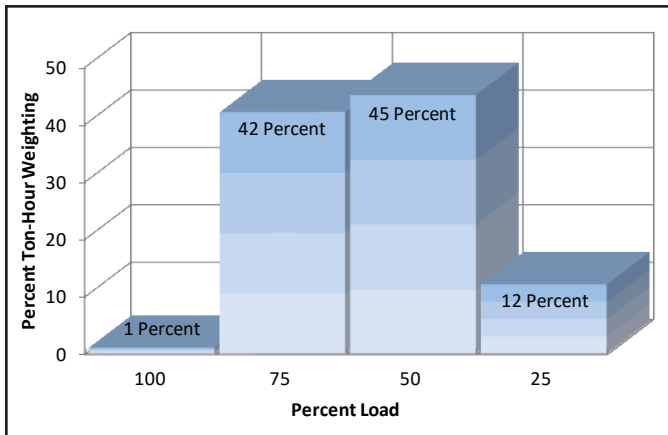

WWV chillers are rated and certified to AHRI Standard 550/590. The ability of the WWV chillers to achieve very high part load efficiencies, as evidenced by their world-class IPLV ratings, is due primarily to the use of a variable frequency drive and the efficient VVR® system. For more information on variable frequency drives, see Integrated Variable Frequency Drive on page 4.

Compliance with ASHRAE Standard 90.1

ASHRAE 90.1 was developed to assist owners and designers in making informed choices on a building’s design, systems, and equipment selection. Model WWV can significantly exceed ASHRAE 90.1 minimum efficiency requirements.

LEED®

For building owners who wish to pursue Leadership in Energy and Environmental Design (LEED®) Green Building Certification, the performance of the WWV may contribute points towards Energy and Atmosphere (EA) Credits.

Points earned for Optimize Energy Performance (formerly EA Credit 1) are awarded based on overall building efficiency. The high efficiency of the WWV will contribute to the total points earned for this credit. Enhanced Refrigerant Management (formerly EA Credit 4) qualification is partially determined by tonnage and refrigerant quantity. Vessel stack and tube count selections will affect the quantity of refrigerant in the chiller.

Consult with your Daikin Applied sales representative for more information.

Factory Testing

All Daikin Applied screw chillers are factory-tested prior to shipment. Operating and safety controls are checked for correct settings and operation. This testing helps reduce field start-up issues and maintain critical construction schedules.

Unit Dimensions

Figure 3: WWV Single Compressor Unit - Opposite End Condenser Connection

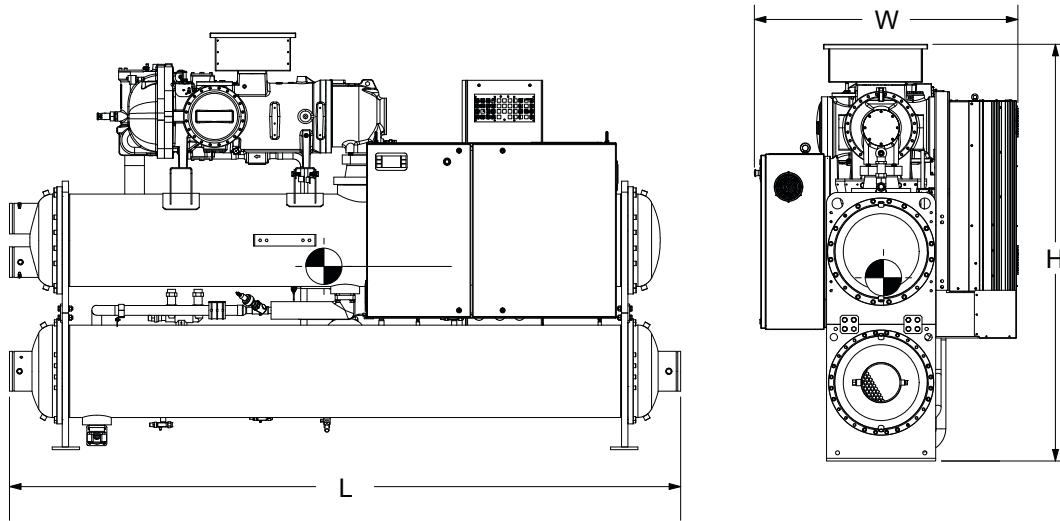

Figure 4: WWV Single Compressor Unit - Same End Condenser Connection

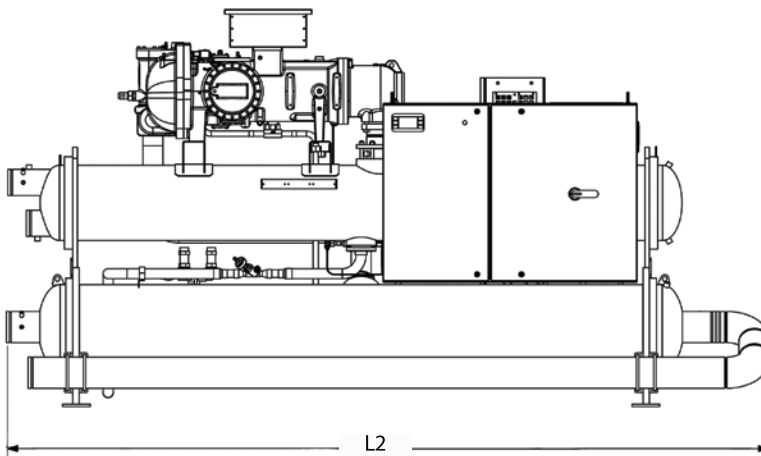

Table 2: WWV Single Dimensions

Compressor (in)	Evaporator Size	Condenser Size	L2		Width (in)	Height (in)
			L Length (in)	same end connection Length (in)		
J	E1610	C1810	150.7	162.2	55.1	84.3
J	E1610	C2010	149.3	163.8	55.1	84.3
M	E1610	C1810	150.7	162.2	55.1	85.3
M	E1610	C2010	149.3	163.8	55.1	85.3
M	E2010	C2010	149.3	163.8	57.1	89.7
M	E2410	C2410	151.4	166.0	61.6	97.4
R	E2010	C2010	149.3	163.8	57.1	92.0
R	E2410	C2410	151.4	166.0	61.6	99.6

Drawing Notes

1. See certified drawings for additional dimensional data.
2. Final connections must allow for 0.5-inch +/- (12.7 mm) manufacturing tolerances.
3. 1.00-inch FPT (25.4 mm) evaporator and condenser relief valves must be piped per ANSI / ASHRAE 15. Number of relief valves is 1 per evaporator and 2 per condenser.
4. Minimum Clearances:
 - See figure below for representative service and operational clearance. Check local codes for any additional clearance requirements.
 - Consult as-built drawings for specific unit configuration as options such as same end condenser connection and marine waterboxes will change the unit footprint.
 - Installation layout should be designed by qualified personnel familiar with local codes.
5. 3.25-inch (83 mm) diameter lifting holes are provided. See installation manual (available at www.DaikinApplied.com) for lifting instructions.
6. Dimensions shown are for standard grooved connections. All water connections are given in standard U.S. nominal pipe sizes. Standard connections are suitable for welding or grooved couplings. ANSI-flanged nozzle connections are available upon request and may change overall unit footprint.
7. Unit vibration isolator pads are provided for field installation and when fully loaded are 0.25 inches (6 mm) thick.
8. The shipping skid adds 4.00 inches (105 mm) to the overall unit height.
9. If main power wiring is brought up through the floor, this wiring must be outside the envelope of the unit.

Figure 5: Representative Service and Operational Clearances (Top View)

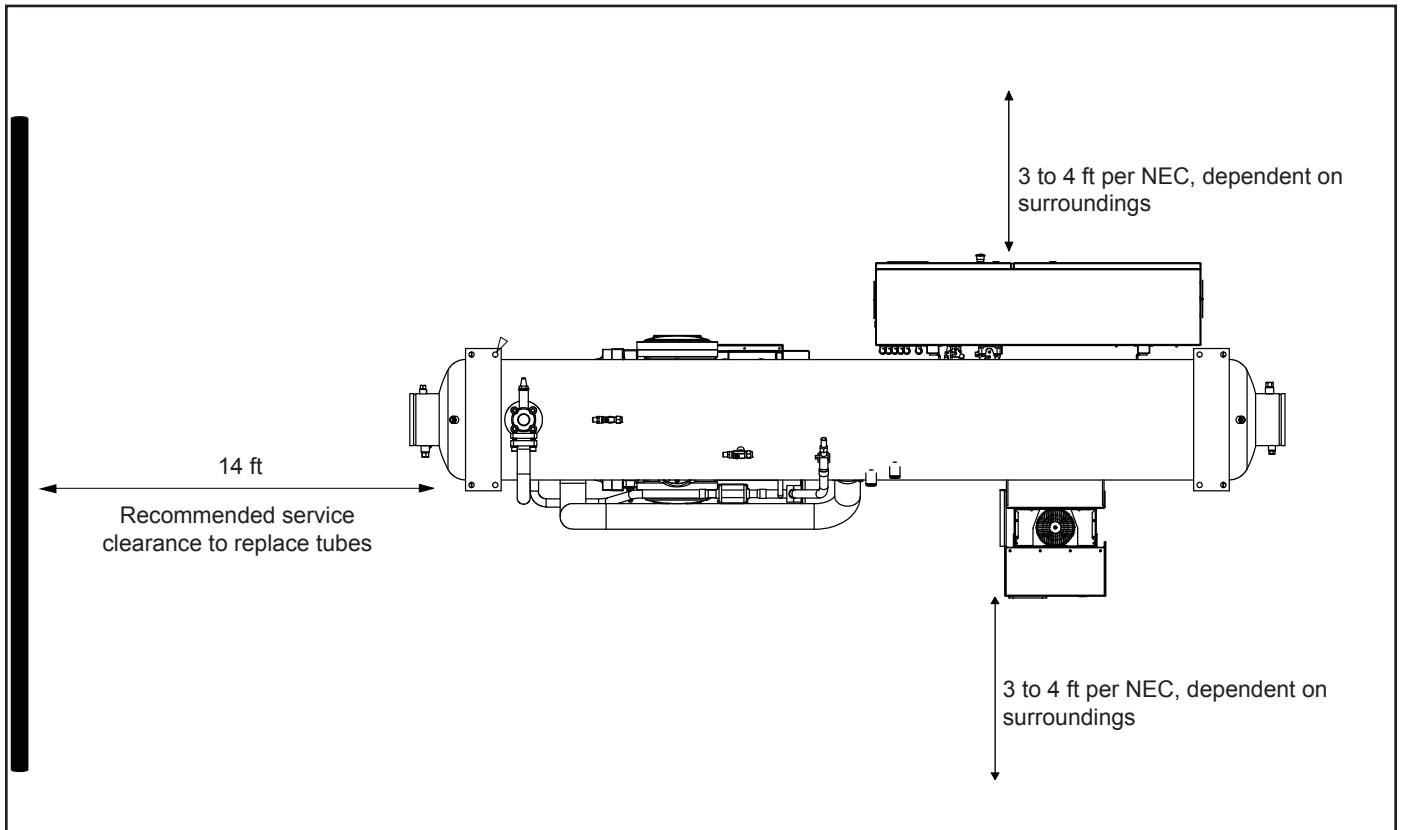

Unit Options

Export Packaging

Export packaging includes a wooden skid to aid in moving the unit, and tight-fitting plastic covering the entire unit to protect it from dirt and grime during transit and storage. Open and closed crating is also offered as options.

Extended Warranties

Extended 1, 2, 3, or 4 year warranties for parts only or for parts and labor are available for the compressor/motor only, the entire unit, or the entire unit including refrigerant.

Certified Witness Test

The specified full and/or part load tests, as ordered, are performed in the presence of the customer under the supervision of a factory engineer. Test data is compiled, certified, and provided to the customer.

Certified Non-Witness Test

The specified full and/or part load tests, as ordered, are performed under the supervision of a factory engineer. Test data is compiled, certified, and provided to the customer.

Refrigerant Charge

Unit ships with a full holding charge of HFC-134a as standard. An inert gas holding charge is available as an option.

Knockdown Shipment

Options for a knockdown shipment to facilitate unit replacement are available.

Sound Attenuation

The model WWV chiller includes low noise construction as standard. Should additional sound attenuation be required, there are factory installed sound reduction options available.

Vessel Options

Single Insulation - Evaporator Shell / Suction Piping

0.75-inch thermal insulation on cold surfaces is available.

Single Insulation - Evaporator Heads and Waterboxes

0.75-inch thermal insulation is available.

Double Insulation - Evaporator Shell / Suction Piping

1.5-inch thermal insulation on cold surfaces — excluding heads and waterboxes — is available.

Double Insulation - Evaporator Heads and Waterboxes

1.5-inch thermal insulation is available.

Marine Water Boxes

Marine waterboxes that allow the end plate of the waterbox to be removed without disconnecting the water piping from the chiller are optional.

Flanged Water Connections

A standard unit will have grooved water connections. ANSI raised face flanges on either the evaporator or condenser are optional. Mating flanges must be provided by the field.

Isolation Shutoff Valves

Factory mounted shutoff valves on the suction and discharge lines of each compressor give the ability to isolate the compressor for service.

Controls Options

BAS Interface Module

Factory-installed on the unit controller for the applicable protocol being used (can also be retrofit):

- BACnet® MS/TP
- BACnet® IP
- BACnet® Ethernet
- LONWORKS®
- Modbus® RTU

Electrical Options

Power Panel High Short Circuit Current Rating

Control panels are rated for the amount of current that can be passed through it and still contain the damage within the enclosure; this value is known as the short circuit panel rating as shown in [Table 3](#) and is standard on all WWV models.

Table 3: Short Circuit Current Ratings (kAmps)

Voltage/Hz	High Short Circuit Panel Rating
460/60	65kA
380/60	
400/50	
575/60	25kA

Ground Fault Protection

Protects equipment from arcing ground fault damage from line-to-ground fault currents less than those required for conductor protection.

RapidRestore®

Allows chillers to restart and reach full load operation quickly in the event of a power loss event. See “RapidRestore®” on page 4 for more details.

Figure 6: Refrigeration System Diagram and Component Location

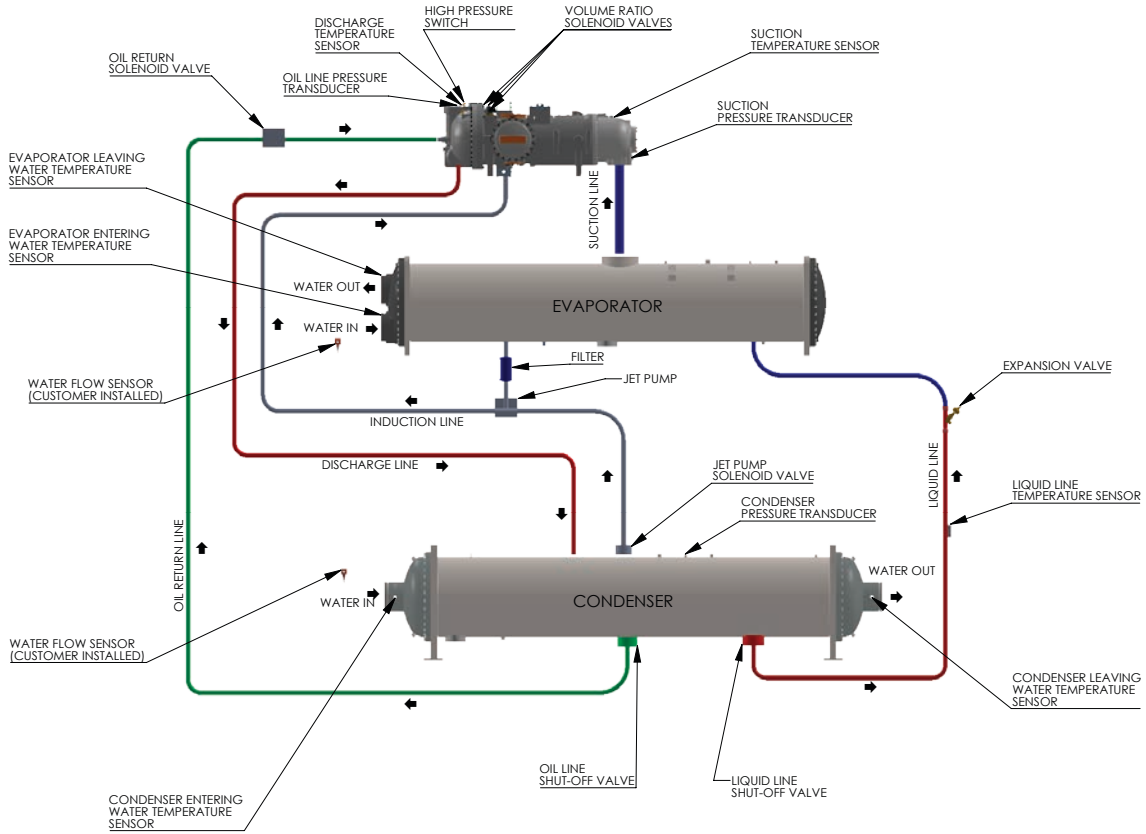

TOP VIEW

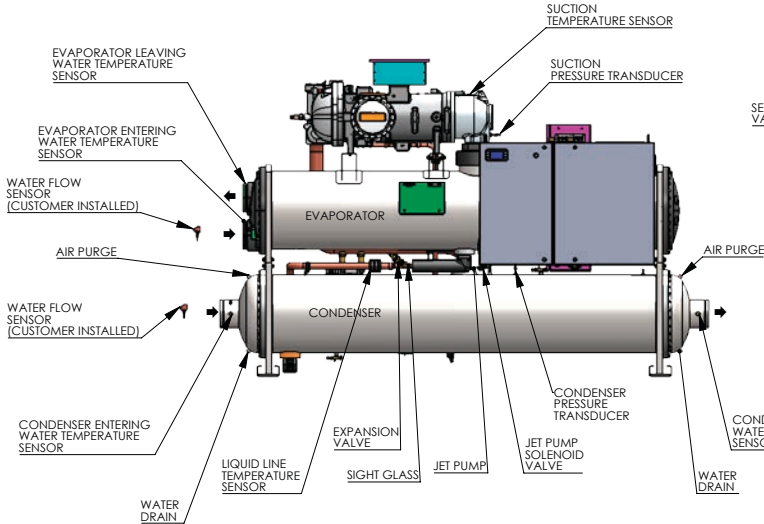
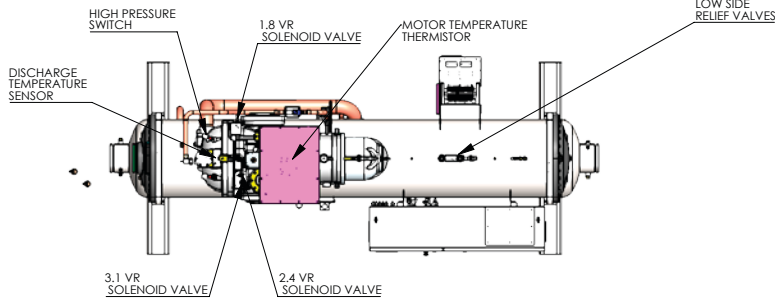

FRONT VIEW

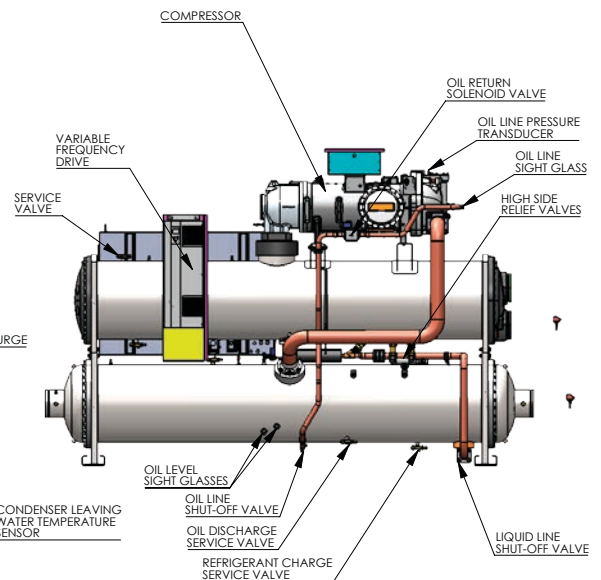

BACK VIEW

Location Requirements

Daikin WWV units are designed only for indoor, weather-protected, non-freezing areas consistent with the NEMA 1 rating on the chiller, controls, and electrical panels. Equipment room temperature for operating and standby conditions is 40°F to 104°F (4.4°C to 40°C).

Vibration Mounting

The WWV chiller has been designed to keep vibrations low. Consequently, floor mounted spring isolators are not usually required. Neoprene mounting pads are shipped with each unit. It is suggested to continue to use flexible piping connectors to reduce sound transmitted into the pipe and to allow for expansion and contraction.

System Design

Water Piping

Field installed water piping to the chiller must include:

- air vents at the high points.
- a cleanable water strainer upstream of the evaporator and condenser inlet connections.
- a flow proving device for both the evaporator and condenser to prevent freeze up. Flow switches, thermal dispersion switches, or Delta-P switches can be used. Note that flow switches are factory provided. Additional flow switches can be used only if they are connected in series with the ones already provided.
- sufficient shutoff valves to allow vessel isolation. The chiller must be capable of draining the water from the evaporator or condenser without draining the complete system.
- matching mechanical connections. All evaporators and condensers have OGS-type grooved water connections (adhering to Standard AWWA C606) or optional flange connections. PVC piping should not be used.

It is recommended that field installed water piping to the chiller include:

- thermometers at the inlet and outlet connections of both vessels.
- water pressure gauge connection taps and gauges at the inlet and outlet connections of both vessels for measuring water pressure drop.

Piping must be supported to eliminate weight and strain on the fittings and connections. Chilled water piping must be adequately insulated.

NOTE: This product, in its standard configuration, is equipped with a shell and tube evaporator with carbon steel shell and copper tubes. The water or other fluid used in contact with the wetted surfaces of the heat exchangers must be clean and non-corrosive to the standard materials of construction. Daikin Applied makes no warranty as to the compatibility

of fluids and materials. Non-compatible fluids may void the equipment warranty. If the compatibility of the fluid with the standard materials of construction is in question, a professional corrosion consultant should administer the proper testing and evaluate compatibility.

Variable Fluid Flow Rates and Tube Velocities

Many chiller system control and energy optimization strategies require significant changes in evaporator water flow rates. This chiller line is well suited to take full advantage of these energy saving opportunities using different combinations of shell sizes, number of tubes, and pass arrangements.

Both excessively high and excessively low fluid flow rates should be avoided. Excessively high fluid flow rates and correspondingly high tube velocities will result in high fluid pressure drops and high pumping power. Extremely high flow rates could potentially lead to tube erosion or corrosion damage. Excessively low fluid flow rates and correspondingly low velocities should also be avoided as they will result in poor heat transfer, high compressor power, sedimentation and tube fouling.

Water Volume

All chilled water systems need adequate time to recognize a load change to avoid short cycling of the compressors or loss of control. The potential for short cycling usually exists when the building load falls below the minimum chiller plant capacity or on close-coupled systems with very small water volumes.

Some of the things the designer should consider when looking at water volume are the minimum cooling load, the minimum chiller plant capacity during the low load period and the desired cycle time for the compressors.

Assuming that there are no sudden load changes and that the chiller plant has reasonable turndown, a rule of thumb of “gallons of water volume equal to two to three times the chilled water gpm flow rate” is often used. A properly designed storage tank should be added if the system components do not provide sufficient water volume.

Ice Mode

Ice making chillers will run very cold fluid during off hours when energy is least expensive to build a tank of ice. The stored ice melts during peak electrical hours to provide as much cooling as possible but there is often a window on warmer days where the chiller will also run to meet the cooling load.

The standard controller software will require “ice” setpoint changes and a digital signal into the controller is required to change to the ice mode and back to standard cooling. In ice building mode, the unit will operate at full load until the shutoff temperature setpoint is reached. Optional double evaporator insulation is recommended for ice mode operation.

Optimizing Efficiency

A key to improving energy efficiency for any chiller is minimizing the compressor pressure lift. Reducing the lift reduces the compressor work and its energy consumption per unit of output.

The optimum plant design must take into account all of the interactions between chiller, pumps, and tower. The Daikin Energy Analyzer™ III program is an excellent tool to investigate entire system efficiency, quickly and accurately. It is especially good at comparing different system types and operating parameters. Contact your local Daikin Applied sales office for assistance on your particular application.

Evaporator

Reducing Evaporator Fluid Flow

Several popular chiller plant control practices — including Variable Primary Flow systems — advocate reducing the evaporator fluid flow rate as the chiller capacity is reduced. This practice can significantly reduce the evaporator pumping power while having little effect on chiller energy consumption. WWV chillers, with their wide range of shell, tube, and pass combinations, are ideal for application in variable evaporator flow systems as long as the minimum and maximum tube velocities are taken into consideration when selecting the chiller.

If it is decided to vary the evaporator water flow rate, the rate of change should not exceed 10% per minute and should not exceed the minimum or maximum velocity limits.

Evaporator Entering Water Temperature

The maximum temperature of water entering the chiller on standby must not exceed 115°F (46.1°C). Maximum temperature entering on start-up must not exceed 90°F (32°C).

Evaporator Leaving Water Temperature

Warmer leaving chilled water temperatures will raise the compressor's suction pressure and decrease the lift, improving efficiency. Using 45°F (7°C) leaving water instead of the typical 42°F (5.5°C) will significantly reduce chiller energy consumption.

Evaporator Water Temperature Difference

The industry standard has been a 10°F (5.5°C) temperature drop in the evaporator. Increasing the drop to 12°F or 14°F (6.6°C or 7.7°C) can improve chiller efficiency and reduce pump energy consumption.

Condenser

Reducing Condenser Fluid Flow

Some chiller plant control practices also advocate reducing the condenser fluid flow rate as the chiller load is reduced. This practice can significantly reduce the condenser pumping

power, but it may also have the unintended consequence of significantly increasing compressor power since the leaving condenser water temperature is directly related to compressor lift and power. The higher compressor power will typically be larger than the condenser pumping power reduction and will result in a net increase in chiller plant energy consumption. Therefore, before this strategy is applied for energy saving purposes it should be extensively modeled or used in an adaptive chiller plant control system which will take into account all of the interdependent variables affecting chiller plant energy. If variable condenser fluid flow is used, the model WWV chiller can operate effectively as long as the minimum and maximum tube velocities are taken into consideration when selecting the chiller.

Reducing Condenser Entering Water Temperature

As a general rule, a 1°F (0.5°C) drop in condenser entering water temperature will reduce chiller energy consumption by two percent. Cooler water lowers the condensing pressure and reduces compressor work. One or two degrees can make a noticeable difference. The incremental cost of a larger tower can be small and provide a good return on investment.

When the ambient wet bulb temperature is lower than design, the entering condenser water temperature of WWV chillers can be lowered to improve chiller performance.

Depending on local climatic conditions, using the lowest possible entering condenser water temperature may be more costly in total system power consumed than the expected savings in chiller power would suggest, due to the excessive fan power required.

In this scenario, cooling tower fans would continue to operate at 100% capacity at low wet bulb temperatures. The trade-off between better chiller efficiency and fan power should be analyzed for best overall system efficiency. The Energy Analyzer™ III program (available from your Daikin Applied sales representative) can optimize the chiller/tower operation for specific buildings in specific locales.

Condenser Water Temperature Control

Differential pressure between the condenser and evaporator is required to maintain proper oil circulation through the chiller. Low temperature or pressure in the condenser may affect the ability of the chiller to maintain oil circulation and result in nuisance trips. This scenario is common during a morning startup when the condenser water temperature is cold.

In order to maintain proper oil circulation, it is required that some form of differential pressure control be installed on the chiller. Acceptable methods of differential pressure control are a bypass valve, throttling valve or variable speed condenser pump. The WWV unit controls have the ability as standard to control either a valve or variable speed condenser pump via 0-10vdc signal.

Electrical Connections

Power wiring connections to the chiller may be done with either copper or aluminum wiring. Wire sizing and wire count must fit in the power connection lug sizing shown in the unit submittals. Copper wire should be sized and installed per the required version of NEC and/or local codes. Aluminum wire shall be installed in accordance with the required version of NECA/AA 104, Standard for Installing Aluminum Building Wire and Cable (ANSI). All wiring within the unit is sized in accordance with the U.S.A. National Electrical Code. Refer to the unit nameplate and the unit submittal documents for specific electrical ratings.

Retrofit Knockdown

It is estimated that fifty percent of retrofit applications require partial or complete disassembly of the chiller. WWV chillers are relatively easy to disassemble due to the small compressor size and simplified refrigerant piping. Two knockdown arrangements, Type A and Type B, are available as options.

Type A Knockdown, “Bolt-Together Construction”

Chillers are built and shipped completely assembled with bolt-together construction on major components for field disassembly and reassembly on the job site.

Type A Scope:

- Chiller components are manufactured with bolt-together construction designed for field disassembly and reassembly on-site.
- Suction and discharge lines have bolt-on flanges.
- Motor cooling line is brazed at mechanical connections.
- Unit ships with vessel and/or head insulation.
- Unit ships with full factory refrigerant charge in the chiller.
- Unit ships with replacement refrigerant gaskets and O-rings, stick-on wire ties, and touch-up paint. Unit is fully tested at the factory prior to shipment.
- Site disassembly and reassembly must be supervised or completed by Daikin Applied service personnel.
- Blockoff plates are required to cover any refrigerant connection left open for extended periods of time. Contact Daikin Applied service to obtain these parts.
- Ideal for retrofit applications where site disassembly is needed due to installation clearances.

Type B Knockdown, “Bolted Construction, Shipped as Parts”

Compressor(s), power boxes and control box are removed at the factory and shipped on separate skids; combined vessel stack is shipped together as a sub-assembly.

Type B Scope:

- All associated piping and wiring remain attached, if possible.
- Suction and discharge lines have bolt-on flanges and remain attached, if possible.
- All free piping ends are capped.
- Unit ships with vessel and/or head insulation, if ordered.
- Refrigerant will not be shipped with the chiller and must be procured by others.
- Compressor(s) and vessels receive an inert gas holding charge.
- Unit ships with replacement refrigerant gaskets and O-rings, stick-on wire ties, and touch-up paint.
- Unit is fully tested at the factory prior to shipment.
- Site reassembly must be supervised or completed by Daikin Applied service personnel. Cost for unit reassembly and supervision by Daikin Applied service is not included in the purchase price of the equipment. Contact Daikin Applied service for pricing.
- Ideal for retrofit applications where it is desired that the compressor(s), power box, and control box be removed at the factory, prior to shipment, and where refrigerant may be secured by others.

Figure 7: Knockdown Piping Connections - Exploded View

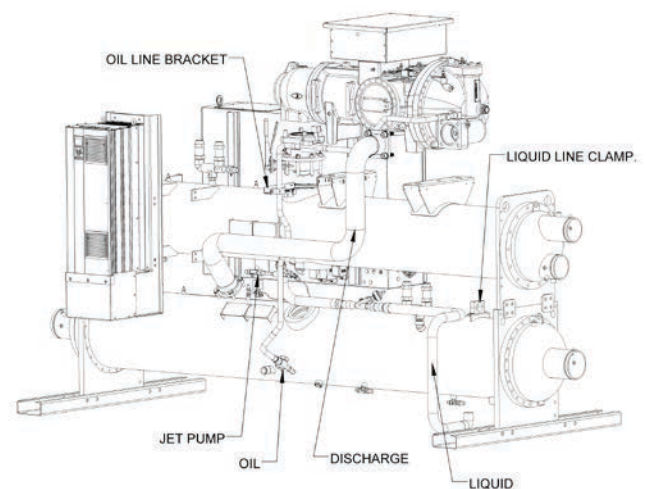

WATER-COOLED SCREW CHILLERS

PART 1 - GENERAL

1.01 SUMMARY

- A. Section includes design, performance criteria, refrigerants, controls, and installation requirements for water-cooled rotary screw packaged chillers.

1.02 REFERENCES

- A. Comply with applicable Standards/Codes of AHRI 550/590, ANSI/ASHRAE 15, ASHRAE 90.1 current version requirements, and ASME Section VIII. ETL listed.

1.03 SUBMITTALS

- A. Submit shop drawings and product data in accordance with specification requirements.
- B. Submittals shall include the following:
 1. Dimensioned plan and elevation view drawings, required clearances, and location of all field connections.
 2. Single line schematic drawing of the field power hookup requirements, indicating all items that are furnished.
 3. If field refrigerant piping is required, furnish a single line piping drawing.
 4. Schematic diagram of the control system indicating points for field connection(s) that fully delineates field and factory wiring.
 5. Installation manuals.

1.04 QUALITY ASSURANCE

- A. Regulatory Requirements: Comply with the codes and standards specified.
- B. Factory Tested: Packaged chiller shall be pressure-tested, evacuated, and fully charged with refrigerant and oil, and be functionally run-tested at the factory.
- C. Chiller must be manufactured in an ISO certified facility.
- D. Factory trained and authorized service personnel shall perform pre-startup checks and startup procedures.

1.05 DELIVERY AND HANDLING

- A. Packaged chillers shall be delivered to the job site completely assembled and charged with refrigerant and oil by the manufacturer.

[OPTIONAL] Knockdown Construction:

Compressor(s), power boxes, and control box shall be removed at the factory and shipped on separate skids; combined vessel stack shall be shipped together as a sub-assembly. Units shall ship with an inert gas holding charge in the compressor and vessels.

- B. Comply with the manufacturer's instructions for rigging and handling.
- C. If unit is to be stored, comply with Manufacturer's instructions for storage.

1.06 WARRANTY

- A. The chiller manufacturer warranty shall cover parts and labor costs for the repair or replacement of defects in material or workmanship,

[OPTIONAL] including refrigerant for the entire unit, for a period of one year from equipment startup or 18 months from shipment, whichever occurs first,

[OPTIONAL] and also include an additional extended warranty for (one OR two OR three OR four) years on (the entire unit) OR (on entire unit including refrigerant coverage) OR (compressor and drive train only).

Warranty support shall be provided by company direct or factory authorized service permanently located near the job site.

1.07 SUSTAINED OPERATIONAL PERFORMANCE AND RELIABILITY

- A. Maintenance of the chiller in accordance with manufacturer's recommendations as published in the installation and maintenance manual shall be the responsibility of the owner.

PART 2: PRODUCTS

2.01 ACCEPTABLE MANUFACTURERS

- A. Basis of Design - Daikin Model WWV, including the standard product features and all special features required per the plans and specifications.
- B. Equal Products - Equipment manufactured by [ENTER MANUFACTURER NAME HERE] may be acceptable as an equal. Equipment proposed "as equal" must meet the specifications including all architectural, mechanical, electrical, and structural details, all scheduled performance, and the job

design, plans and specifications.

2.02 UNIT DESCRIPTION

- A. Provide and install as shown on the plans, factory assembled, factory charged with R-134a, and factory run-tested, water-cooled, rotary screw compressor packaged chillers in the quantity and capacity specified. Each chiller shall consist of a single screw compressor, evaporator, condenser, control system and all components necessary for protected and controlled unit operation.

2.03 DESIGN REQUIREMENTS

- A. General: Provide a complete rotary screw packaged chiller as specified and as shown on the drawings. The unit shall be in accordance with the standards referenced in section 1.02.
- B. Performance: Refer to the schedule of performance on the drawings. The chiller system shall be

capable of stable minimum part load operation without hot gas bypass.

- C. Acoustics: Manufacturer must provide both sound power and sound pressure data in decibels. Sound pressure data per AHRI 575 must be provided in 8 octave band format at full load. In addition, A-weighted sound pressure at 3 feet should be provided at 100% load points to identify the full operational noise envelope. Sound power must be provided in 1/8 octave band format to highlight any tonal quality issues.

If manufacturer cannot meet the noise levels (per the attached chart), sound attenuation devices and/or barrier walls must be installed to meet this performance level.

[OPTIONAL] Each compressor shall have a factory installed, rigid, sound enclosure with removable panels for compressor access.

Sound Pressure (at 3 feet)								
63 Hz	125 Hz	250 Hz	500 Hz	1K Hz	2K Hz	4K Hz	8K Hz	Overall dBA

Sound Power								
63 Hz	125 Hz	250 Hz	500 Hz	1K Hz	2K Hz	4K Hz	8K Hz	Overall dBA

2.04 CHILLER COMPONENTS

- A. Compressors:
 - 1. The compressors shall be field serviceable, semi-hermetic, single-rotor screw type with one central helical rotor meshing with two opposing gaterotors. The gaterotor contact element shall be constructed of engineered composite material, dimensionally stable up to 1500°F and wear resistant for extended life. If a twin-screw design is used, the manufacturer shall provide an extended 5-year parts and labor warranty covering all additional moving parts.
 - 2. Compressor Motors: Motors shall be high torque, two pole, semi-hermetic, squirrel cage induction type with inherent thermal protection on all three phases and cooled by suction gas.
 - 3. Compressor Motor Control: Each compressor shall be equipped with a VFD providing compressor speed control as a function of the cooling load. Each VFD shall provide controlled motor acceleration and deceleration, and shall provide protection for the following conditions: electronic thermal overload, over/under current, stalled motor, input and output phase loss, high

load current, and current unbalance. The VFD shall provide a minimum 95% displacement compressor power factor at all load points. Compressors used in VFD controlled units must have electrically insulated, ceramic bearings to mitigate bearing and/or lubricant damage from stray electric current passage. Compressor shall be able to control compression ratio to optimize efficiency at all operating conditions. Units without this protection must have an extended 5-year compressor warranty.

- a. The unit controller shall display the following data:
 - Output Frequency
 - Output Current
 - Output Voltage
 - Output Power
 - Fault Code
- b. The unit controller shall display the following alarms and faults:
 - Over Current-Hold
 - Over Current-Unload
 - Over Current-Alarm

- Overheat-Hold
 - Overheat-Unload
 - Overheat-Alarm
 - Communication Fault
 - System power not three phase
 - Phase sequence incorrect
 - Line frequency less than 25 Hz
 - Line frequency more than 72 Hz
 - Excessive current unbalance
 - Operating parameters lost
 - No current after “Run” command
 - Undercurrent trip occurred
 - Overcurrent trip occurred
 - Control power too low
 - Motor stalled during acceleration
 - External fault
- c. The unit controller shall display the following operating messages:
- Line voltage not present
 - Voltage present, starter ready
 - Motor accelerating
 - Motor at full speed
 - Motor at full speed, ramp time expired
 - Stop command received, motor decelerating
 - Thermal overload has reached 90% to 99%
 - Thermal overload at 100%, motor stopped
 - Thermal overload reduced to 60%, motor can restart
 - Passcode enabled
 - Passcode disabled
 - Thermal overload content in percentage
- B. Evaporator: The evaporator shall be designed, inspected, and stamped in accordance with ASME Section VIII requirements. It shall be mounted and piped in the unit.

[OPTIONAL] The evaporator vessel, including water heads, suction line, and any other component or part of a component subject to condensing moisture shall be insulated with $\frac{3}{4}$ " (19 mm) thick CFC and HCFC-free closed-cell flexible elastomeric foam insulation material with 100% adhesive coverage. The insulation shall have an additional outer protective layer of 3mm thick PE embossed film to provide superior damage resistance. Insulation without the protective outer film shall not be acceptable. UV resistance level shall meet or exceed a rating of ‘Good’ in accordance with the

UNI ISO 4892 - 2/94 testing method. All joints and seams shall be carefully sealed to form a vapor barrier.

[OPTIONAL] The evaporator shall have 1.5-inch (38 mm) thick CFC and HCFC-free closed-cell flexible elastomeric foam insulation material with 100% adhesive coverage.

The evaporator shall have [dished heads with valved drain and vent connections] –OR– [shall be equipped with marine waterboxes with removable covers and vent and drain connections].

The evaporator shall have standard left-hand [grooved couplings] –OR– [flanged connections] when looking at the control panel end.

The evaporator shall be equipped with a factory-supplied and wired flow switch.

C. Condenser:

1. The condenser shall be of the shell-and-tube type, designed, constructed, tested and stamped according to the requirements of the ASME Code, Section VIII. The tubes shall be individually replaceable and secured to the intermediate supports without rolling.
2. The condenser shall have [0.025-inch] tubes. Water connections shall be [grooved suitable for grooved couplings] —OR— [flanged]. The condenser shall have [dished heads with valved drain and vent connections] –OR– [shall be equipped with marine waterboxes with removable covers and vent and drain connections]. The water side shall be designed for a minimum of [150 psig].
3. Re-seating type spring loaded pressure relief valves according to ASHRAE 15 safety code shall be furnished. The condenser shall be provided with dual relief valves equipped with a transfer valve so one relief valve can be removed for testing or replacement without loss of refrigerant or removal of refrigerant from the condenser. Rupture disks are not acceptable.
4. Provide factory-supplied and wired thermal dispersion water flow switches on each vessel to prevent unit operation with no or low water flow.
5. [OPTIONAL]: Provide suction and discharge isolation valves to hold the unit refrigerant charge in the condenser during servicing or provide a separate pumpout system and storage tank sufficient to hold the charge of the largest unit being furnished.

- D. Refrigerant Circuit: The unit must have a single refrigerant circuit with one compressor. The

refrigerant circuit shall include an electronic expansion valve, liquid line shut-off valve, replaceable core filter-drier, and sight glass with moisture indicator.

E. Electrical Panel:

1. A centrally located, UL-approved weatherproof electrical control panel shall contain the unit control system, control interlock terminals and field-power connection points. Box shall be designed in accordance with NEMA 1 rating. Hinged control panel access doors shall be tool-lockable. Door mounted controller shall be provided to allow control of chiller without opening panel door.
2. Power Section: Power supply shall be to a high short circuit current rated panel with a factory-mounted single-point high interrupting capacity unit disconnect switch breaker.
3. Control Section: The control logic shall be designed to maximize operating efficiency and equipment life with protections for operation under unusual conditions and to provide a history of operating conditions. The system shall intelligently stage the unit to sustain leaving water temperature precision and stability while minimizing compressor cycling.

Equipment protection functions controlled by the microprocessor shall include high discharge pressure, loss of refrigerant, loss of water flow, freeze protection, and low refrigerant pressure.

User controls shall include auto/stop switch, chilled water set-point adjustment, anti-recycle timer, and digital display with water temperature setpoint, operating temperatures and pressures, and diagnostic messages.

The following features and functions shall be included:

- a. Durable liquid crystal display (LCD) screen type, having minimum four 20-character lines with 6 key input pad conveniently mounted on the unit controller. Default language and units of measure shall be English and IP respectively. Messages shall be in plain English. Coded messages, LED indicators and LED displays are not acceptable.
- b. Separate control section and password protection for critical parameters.
- c. Remote reset of chilled water temperature using a 4-20mA signal.
- d. Soft-load operation, protecting the compressor by preventing full-load operation

during the initial chilled fluid pull-down period.

- e. Non-volatile program memory allowing auto-restart after a power failure.
- f. Recording of safety shutdowns, including date-and-time stamp, system temperatures and pressures. A minimum of six previous occurrences shall be maintained in a revolving memory.
- g. Start-to-start and stop-to-start cycle, giving minimum compressor off time and maximizing motor protection.
- h. Discharge pressure control.
- i. Pro-active compressor unloading when selected operating parameters exceed design settings, such as high discharge pressure or low evaporator pressure.
- j. Diagnostic monitoring of unit operation, providing a pre-alarm signal in advance of a potential shutdown, allowing time for corrective action.

[OPTIONAL]: The factory-mounted DDC controller shall support BAS operation via Open Choices™ standard protocols using either BACnet MS/TP, BACnet IP or BACnet, or LonMark. The information communicated between the BAS and the factory mounted unit controllers shall include the reading and writing of data to allow unit monitoring, control and alarm notification as specified in the unit sequence of operation and the unit points list.

[OPTIONAL]: The unit shall be equipped with a RapidRestore® feature to restart a unit within 35 seconds of power interruption and a Fast Loading feature to minimize the time to restore full load operation.

[OPTIONAL] The unit shall be equipped with an emergency stop button on the control panel door.

[OPTIONAL]: The unit shall be equipped with ground fault protection.

PART 3 - EXECUTION

3.01 INSTALLATION

- A. Install in strict accordance with manufacturer's requirements, shop drawings, and contract documents.
- B. Measures must be taken to avoid accumulation of debris in the evaporator and condenser during initial system flushing. A cleanable strainer must be placed in the supply water line prior to the inlet of

the evaporator and condenser

Care shall be exercised when welding pipe or flanges to the evaporator or condenser to prevent any slag from entering the vessel. Any welds after the strainer must be mechanically cleaned to avoid slag entering the vessel.

- C. Adjust and level chiller in alignment on supports.
- D. Coordinate electrical installation with electrical contractor.
- E. Coordinate controls with control contractor.
- F. Provide all required accessories or accompanying parts to insure a fully operational and functional chiller.

3.02 STARTUP

- A. Provide Factory Authorized starting of chillers, and instruction to the owner on operation and maintenance.



**DAIKIN APPLIED AMERICAS INC.
LIMITED PRODUCT WARRANTY
(North America)**

Daikin Applied Americas Inc. dba Daikin Applied (“Company”) warrants to contractor, purchaser and any owner of the product (collectively “Owner”) that Company, at it’s option, will repair or replace defective parts in the event any product manufactured by Company, including products sold under the brand name Daikin and used in the United States or Canada, proves defective in material or workmanship within twelve (12) months from initial startup or eighteen (18) months from the date shipped by Company, whichever occurs first. Authorized replaced parts are warranted for the duration of the original warranty. All shipments of such parts will be made FOB factory, freight prepaid and allowed. Company reserves the right to select carrier and method of shipment.

In addition, labor to repair or replace warranty parts is provided during Company normal working hours on products with rotary screw compressors and centrifugal compressors. Warranty labor is not provided for any other products.

Company’s liability to Owner under this warranty shall not exceed the lesser of the cost of correcting defects in the products sold or the original purchase price of the products.

PRODUCT STARTUP ON CENTRIFUGAL AND SCREW COMPRESSOR PRODUCTS IS MANDATORY and must be performed by a Daikin Applied or a Company authorized service representative.

It is Owner’s responsibility to complete and return the Registration and Startup Forms accompanying the product to Company within ten (10) days of original startup. If this is not done, the ship date and the startup date will be deemed the same for warranty period determination, and this warranty shall expire twelve (12) months from that date.

EXCEPTIONS

1. If free warranty labor is available as set forth above, such free labor does not include diagnostic visits, inspections, travel time and related expenses, or unusual access time or costs required by product location.
2. Refrigerants, fluids, oils and expendable items such as filters are not covered by this warranty.
3. This warranty shall not apply to products or parts which (a) have been opened, disassembled, repaired, or altered by anyone other than Company or its authorized service representative; or (b) have been subjected to misuse, negligence, accidents, damage, or abnormal use or service; or (c) have been operated, installed, or startup has been provided in a manner contrary to Company’s printed instructions, or (d) were manufactured or furnished by others and which are not an integral part of a product manufactured by Company; (e) have been exposed to contaminates, or corrosive agents, chemicals, or minerals, from the water supply source, or (f) have not been fully paid for by Owner.

ASSISTANCE

To obtain assistance or information regarding this warranty, please contact your local sales representative or a Daikin Applied office.

SOLE REMEDY

THIS WARRANTY CONSTITUTES THE OWNER’S SOLE REMEDY. IT IS GIVEN IN LIEU OF ALL OTHER WARRANTIES. THERE IS NO IMPLIED WARRANTY OF MERCHANTABILITY OR FITNESS FOR A PARTICULAR PURPOSE. IN NO EVENT AND UNDER NO CIRCUMSTANCE SHALL COMPANY BE LIABLE FOR INCIDENTAL, INDIRECT, SPECIAL, CONTINGENT OR CONSEQUENTIAL DAMAGES, WHETHER THE THEORY BE BREACH OF THIS OR ANY OTHER WARRANTY, NEGLIGENCE OR STRICT LIABILITY IN TORT.

No person (including any agent, sales representative, dealer or distributor) has the authority to expand the Company’s obligation beyond the terms of this express warranty or to state that the performance of the product is other than that published by Company.

For additional consideration, Company will provide an extended warranty(ies) on certain products or components thereof. The terms of the extended warranty(ies) are shown on a separate extended warranty statement.



Daikin Applied Training and Development

Now that you have made an investment in modern, efficient Daikin equipment, its care should be a high priority. For training information on all Daikin HVAC products, please visit us at www.DaikinApplied.com and click on Training, or call 540-248-9646 and ask for the Training Department.

Warranty

All Daikin equipment is sold pursuant to its standard terms and conditions of sale, including Limited Product Warranty. Consult your local Daikin Applied representative for warranty details. To find your local Daikin Applied representative, go to www.DaikinApplied.com.

Aftermarket Services

To find your local parts office, visit www.DaikinApplied.com or call 800-37PARTS (800-377-2787).

To find your local service office, visit www.DaikinApplied.com or call 800-432-1342.

This document contains the most current product information as of this printing. For the most up-to-date product information, please go to www.DaikinApplied.com.

Products manufactured in an ISO Certified Facility.